

**Study on Integrated Sediment
Management in an Active Volcanic Basin**

By

IKHSAN JAZAUL

2010

Abstract

Mass and sediment movements in a river basin give us benefit as well as natural disasters. Mass movement such as pyroclastic flows, debris flows, and landslides causes often destructive sediment disasters to human being as a short term event. Also, sediment movement such as erosion, bed load, suspended load and wash load generates important problems on basin management such as reservoir sedimentation as a long-term event. The mass and sediment movements give negative impacts on a river basin and human being. This is an aspect of natural disaster in mass and sediment movements. On the other hand, sediment deposits of bed load, suspended load, debris flow, and so on are the potential sediment resources in a basin. Huge mass movement brings excess sediment, but it is also one of the important sediment resources. This is an aspect of natural resources in mass and sediment movements. In sediment management for a basin, it is essential to consider these two aspects together. In other words, sediment disaster management and sediment resources management should be well synchronized. For example, sabo works and channel works for sediment disaster mitigation influence a role of sediment as resources in a river basin. Inappropriate sediment resources management could result in devastation of the basin and produce many weak points for sediment disaster management. The sediment disaster management can function only under an appropriate sediment resources management.

Safety, river environment, and utilization are commonly the target elements of sediment management. As a change in an element by sediment management may affect the other two elements, and the priority among three elements depends on stakeholders. Current conditions on these elements in a basin are changed toward the targets by sediment management and consequently the socio-economic conditions are expected to be improved. Hence, it is necessary to develop a method to evaluate the effect of sediment management on each element and an integrated evaluation method for socio-economic effect. In this study, taking Mount Merapi basin as an investigation field, these methods for an active volcanic basin were developed and some case studies were conducted.

Mount Merapi located in Yogyakarta is one of the most active volcanoes in Indonesia. It has erupted regularly and the eruption has been more active in the last

20 years. The eruptions have produced huge sediment and caused pyroclastic flows and debris flows, threatening people live and assets in the downstream area. Sediment disaster mitigation has been implemented and sabo facilities have been constructed to mitigate the sediment disasters. On the other hand, local people have used deposited sediment as construction material. People came to take the sediment as much as possible for supporting regional development and their additional incomes. Moreover, huge eruption has accelerated their sand mining activities. Once sand mining is much activated, it is difficult to reduce a sand mining business. Rather sand mining area has spread through the basin from the river. Uncontrolled sand mining has caused the bed degradation and basin wasting, and has given negative impact for safety and environment.

This study focuses on developing a framework of integrated sediment management in Mount Merapi volcanic basin considering three elements, namely utilization, safety and environment. Then, some case studies of sediment management were conducted and the effectiveness of sediment management on socio-economic condition was also discussed considering the current situation. The objectives of this study are: (1) to figure out the socio-economical and environmental conditions in Mount Merapi volcanic basin as a background of sediment management for the basin, (2) to develop a concept of sustainable sand mining management as one of the main management tools in Mount Merapi basin, (3) to develop a framework of integrated sediment management, which considers both of sediment disasters and sediment resources and (4) to develop a method to evaluate the effect of sediment management from a socio-economic point of view.

To achieve first objective of this study, a questionnaire survey for inhabitants and literature investigation were carried out. The result shows that sediment is an important resource to support inhabitants' daily life through sand mining activity. The activity has a positive socio-economic impact on Mount Merapi basin by providing job opportunities and giving additional income for inhabitants as well as local government. Inhabitants and local government give a good awareness to sabo works. Sabo works have constructed for two purposes; first for sediment disaster mitigation and second for supporting regional development such as bridges and an irrigation water intakes. As a result, safety is secured and transportation access is more convenient. However, due to the excessive sediment resources use, the environmental condition in Mount Merapi basin tends to be worse due to riverbed degradation and instability of river

infrastructures. Hence, it is necessary to develop a new concept of sediment management in Mount Merapi basin.

Hence, a concept of sustainable sand mining management combined with consolidation works was discussed as one of the main management tools in Mount Merapi basin. In this management, the sediment produced at Mount Merapi is used as much as possible with preventing severe riverbed degradation and aggradation. This is implemented to overcome the sediment problems on both of disaster and resource. Steps to estimate the allowable sand mining volume were proposed as follows; (i) determining a designed bed slope, (ii) calculating sediment discharge to the sea, (iii) deciding the allowable sand mining volume based on the designed sediment supply rate, and (iv) determining the location of groundsills.

The concept of sustainable sand mining management with consolidation works was applied to Progo River in Mount Merapi basin. Simulations of riverbed variation were carried out under a sediment supply rate equal to the averaged sediment production rate in the basin by means of one-dimensional bed deformation model. The simulation result under no sand mining condition shows rather large riverbed aggradation in the upstream reach. Therefore, sand mining could be one of the tools in sediment run off control. If the sand mining volume is 39 % of the annual average sediment production, the riverbed is in equilibrium condition without aggradation and degradation. Also the sand mining is an important role in the socio-economic condition. So, the simulation for sediment management with sand mining control and consolidation works was performed. The simulation result shows that severe bed degradation takes place in the upstream reach if the present sand mining activity is kept without groundsill. Consolidation works are necessary to prevent the bed degradation. Thus, the bed variation was simulated for the coupled management of sand mining control and consolidation works. The simulation result shows that a series of groundsill can protect the riverbed from degradation even if more than 39% of sediment production is taken. However, the groundsills cannot prevent the serious bed degradation if the current sand mining activity is kept.

A huge eruption frequently takes place at Mount Merapi. At that time, severe bed aggradation occurs and all the groundsills installed by the above management could be buried with sediment. Sabo works should be combined with the proposed sediment management to prevent the excess sediment supply to the main river. A simulation was conducted considering sabo works in a tributary as well as sand

mining control and consolidation works. The sediment discharge to the main river is estimated and it is found that the tributary installed some sabo dams can function as a buffer zone for the huge eruption. This sediment management composed of sand mining control, consolidation works and sabo works is very effective for Mount Merapi basin.

Finally, an integrated evaluation method for sediment management was discussed from a socio-economic point on safety, environment, and sediment utilization and the case study of sediment management was evaluated by means of this method. To evaluate the effects of the sediment management, some parameters on safety, utilization, and environment have been introduced. From a utilization point of view, job opportunity, additional income of local people and tax income to local government were used to evaluate the effectiveness of the sediment management. The risk degree of river infrastructures was used to describe the effect of the sediment management on a safety aspect. To evaluate the effects of the sediment management on environment, the mean diameter of grain size distribution of riverbed surface was used. On the coordinate system designating these elements, the direction of change in basin condition by the sediment management can be predicted, so that the most preferable sediment management can be decided. The results indicate that the proposed sediment management tends to give the negative impacts on sediment utilization. However, the case study of sediment management will give positive impacts on safety and environment condition. Evaluation result from a social-economic point of view shows that the case study of sediment management reduces job opportunity and additional income for inhabitants as well as tax income for government. However, the management providing safety and good environment condition results in improvement of the social condition. Therefore, it is necessary to make another policy for creating job opportunity for inhabitants to support the sediment management.

This study is a pioneer research on integrated sediment management in active volcanic basins. There are many social and economic aspects in evaluating the effect of sediment management. The proposed method is available for effect evaluation of sediment management, but it may be recognized as a primary method because the aspects considered are not enough and the standard for evaluation is rather simple. In future, I will develop this study collaborating with social, economic, and environmental researches.

Key words: *Sediment management, sediment disaster, resources, volcanic basin*

Acknowledgements

This thesis has benefitted from collaboration with and contribution by many people. Therefore, I want to thank a number of people for their assistance while I was preparing for this thesis and completing my doctoral study in Kyoto University.

First, I would like to express my deepest gratitude to my academic supervisor, Prof Masaharu Fujita, Disaster Prevention Research Institute of Kyoto University, who has provided many important ideas for completion of my study. His untiring effort, forethoughtful guidance, continuous encouragements, and personal attention during the whole period of my study, have become my source of motivation. Without him, it would not have been possible for me to complete my study. Finally, Prof Masaharu Fujita has also kindly recommended me to the scholarship provided by Monbukagakusho under Kyoto University-International Doctoral Program, which funded my study in Kyoto. The next person I would like to express my gratitude is Prof Hajime Nakagawa and Prof Tetsuya Sumi, Disaster Prevention Research Institute of Kyoto University, who have given their valuable comments and suggestions for refining the thesis.

Herein, I would like to express my sincere appreciation to Dr. Hiroshi Takebayashi, for his invaluable guidance, suggestions, encouragement, kindness, and patience during my study. I also would like to express my gratitude to Dr. Daizo Tsutsumi, for his inspiring guidance and kind hospitality during field observation in Hodaka Sedimentation Observatory. My gratitude is also for Dr. Shusuke Miyata for kind support, help and fruitful discussion.

I thank all the professors and friends in the Research Center for Fluvial and Coastal Disaster, Disaster Prevention Research Institute of Kyoto University, who have made my academic experience rich and memorable. I thank all the staffs in Ujigawa Open Laboratory, Disaster Prevention Research Institute of Kyoto University, for their support in routine administrative and experiment.

I wish to express my gratitude to Ms Yoko Kamiya and Mrs Junko Amano, for their help during my study. I also thank to Mr. Hiroyuki Teshima and Mr. Hiroaki Izumiyama for their support in many ways. I thank to Mr. Masaki Takebe, Mr. Yuichiro Suzuki, Mr. Oshio Seitaro, Mr. Yuki Fukushima, Mr. Tatuya Nakamoto, Mr. Toan Nguyen MM, Mr. Hironao Kobayashi, Mr. Tamaki, Mr. Yoshiaki Samoto, Ms Tomoko Kyuka and other members of Laboratory of Erosion and Sediment Runoff Control Engineering of Kyoto University for their encouragement, cooperation, and unforgettable friendship.

I would like to express my special thanks to Prof Djoko Legono, Gadjah Mada University, for giving me the recommendation to start my doctoral study at Kyoto University. Also I would like to express my thanks for Prof. Bambang Triatmodjo, the head of Civil and Environmental Engineering Dept., and Dr. Adam Pamudji R., Gadjah Mada University. Special thanks to Dr. Muhammad Sulaiman, Dr. Adhy Kurniawan, Mr. Nur and his survey team, Mr. Ade and his group, and Mr. Puji Harsanto for their kind support and help, so that my research can be finished. I also would like to say my special thanks to Dr. Joko Sulisty, Dr. Kiki Vierdayanti and my best friends that I cannot mention one by one here, in order that my life in Kyoto is unforgettable.

I gratefully acknowledge to the Indonesian Government and Muhammadiyah University of Yogyakarta for having given me the opportunity and supports for continuing my study, and to the Japanese Government through Monbukagakusho for providing me the scholarship during my study. Finally, I am deeply grateful to my wife, my children, my parents, my parents in law and all of my family members for their kind love, untiring support, and encouragement. Special for my loved wife, Lailatur Rohmah M., I am so sorry because during my study in Japan of 3 years, you must look after our children alone. In addition, for my children, Alya U. Ikhsan, Azizah Ikhsanurrohmah, M. Ismail A. Ikhsan, your father is sorry because you have to grow up for 3 years without a father. Thank you all.

Kyoto, August 2010

Table of Contents

Abstract	i
Acknowledgements	v
Chapter 1 Introduction	1
1.1 Worldwide Problems on Sediment Disasters and Sediment Resources	1
1.1.1 Aspects of sediment	1
1.1.2 Sediment related disasters	2
1.1.3 Sediment resources	8
1.1.4 Degradation and aggradation problems	10
1.2 Global Warming Impacts on Sediment Related Problems	11
1.3 Sediment Related Disasters and Resources in Indonesia	14
1.4 Necessity of the Combined Management for Sediment Disaster and Resources	16
1.5 Objectives of the Research	18
1.6 Thesis Outline	21
References	23
Chapter 2 Socio-Economic and Environment Conditions in Mount Merapi Basin	27
2.1 Introduction	27
2.2 Questionnaire Survey	28
2.2.1 Background	28
2.2.2 The survey area and location	29
2.2.3 Respondents	36
2.2.4 Questionnaire	37
2.2.5 The results of questionnaire survey	42
2.3 Socio-Economic Condition in Mount Merapi Basin	52
2.3.1 Demography	53
2.3.2 Main industry in the study area	57
2.3.3 Labor forces	58
2.3.4 Current situation of sand mining	59

2.3.5 Sediment disaster in the upper area	62
2.4 Environment Condition	62
2.4.1 River systems	62
2.4.2 Environment conditions in upper area	66
2.4.3 Environment conditions in downstream area	66
2.5 Summary	73
References	74
Chapter 3 Sediment Disaster and Resource Management	77
3.1 Mount Merapi Activity	77
3.1.1 Introduction	77
3.1.2 Sediment balance	80
3.2 Current Situation of Sediment Disaster and Resource Management	81
3.2.1 Sediment disaster	81
3.2.3 Sediment disaster countermeasures	89
3.2.4 Sediment resource management	95
3.2.5 Effect of the previous sediment management	108
3.3 Sustainable Sand Mining Management	117
3.3.1 Concept of sustainable sand mining management	117
3.3.2 Allowable sand mining volume in Mount Merapi basin	119
3.4 Sustainable Management Combined With Consolidation Works	122
3.4.1 Simulation model	122
3.4.2 Simulation using uniform sediment	125
3.4.3 Simulation using non-uniform sediment	134
3.4.4 Effect of variation of sediment production	143
3.5 Sediment Resources Management Combined With Sabo Works	147
3.5.1 Required volume of sabo works	147
3.5.2 Effects of sabo works	151
3.6 Summary	165
References	165

Chapter 4	A Method for Effect Evaluation of Sediment Management	167
4.1	Introduction	167
4.2	Evaluation of Sediment Management	170
4.2.1	Introduction	170
4.2.2	Socio-economic aspect	172
4.2.3	Effect of sediment management on environment aspect	191
4.2.4	Effect of sediment management on environment, utilization, and safety	194
4.2.5	Present and preferable conditions	206
4.3	Bed Porosity Variation Model	208
4.3.1	Experimental study	208
4.3.2	Estimation of porosity	211
4.3.3	A bed-porosity variation model	212
4.3.4	Results and discussion	214
4.4	Preferable Sediment Management	228
4.4.1	Disaster mitigation in upper area due to the volcanic activity	228
4.4.2	Riverbed stabilization in the lower Progo River and Opak River	229
4.4.3	Sustainable sand mining management	231
4.4.4	Regional development	233
4.5	Summary	234
	References	235
Chapter 5	Conclusions and Recommendations	237
5.1	Conclusions	237
5.1	Recommendations	240
	List of Figures	243
	List of Photos	255
	List of Tables	257
	Curriculum Vitae	259

Chapter 1

Introduction

The purpose of this chapter is to describe the background, the problem definitions, the objectives, and the scope of the research. Firstly, the worldwide problems on sediment disasters as well as on sediment resources are summarized. Then the global warming and its impact on sediment related disasters are introduced. Subsequently the problem on sediment disasters and resources in Indonesia, including the both problems in Mount Merapi basin are as well pointed out. After the problem description, objectives and motivation of this research are described. Finally, the outline of this thesis is introduced in the form of a brief synopsis of each chapter.

1.1 Worldwide Problems on Sediment Disasters and Sediment Resources

1.1.1 Aspects of sediment

Many terms and phrases are used to describe sediment. The meaning of sediment is the different thing to various people (Owens, 2008). Generally, the definition of sediment is solid material, which is referred to soil, clay, sand, and rock. The public or non-scientific community often use terms such as mud, dirt, and sludge, when referring to sediment. Certain groups of scientists also use mud as a term when referring to fine organic and inorganic sediment, i.e. clay and silt-sized material. For engineers in charge of river sediment management, sediment is dredged material.

In this paper, the sediment is looked at from the different two aspects. First aspect is the sediment as resources for construction material and agricultural land. Also, as a function of the sediment, habitat formation is one of the important elements of the aspect. Sediment provides benefits to people and river ecosystem as resources. Sediment plays an important role to construction and conservation of ecosystem. Second aspect is the sediment directly causing disasters such as pyroclastic flow, debris flow and lava flow. Bed load, suspended load and wash load are also the important sediment transport process indirectly causing disasters in

river basins. Sediment poses problems when there is too little sediment supply or also much sediment supply to river basins. According to Salomons (2005), too little sediment transport in river basins results in riverbed degradation, riverbanks erosion, coastal erosion, loss of wetlands and so on. When amount of sediment transported in river basins is too much, some problems such as aggradation and inundation could appear. It is quite often that sediment causes disasters for human life, for example landslides, pyroclastic flows and debris flows.

1.1.2 Sediment related disasters

Environment damages and loss of human lives caused by natural hazards on every continent occur very often. Every year, thousands of casualties and amazing economic impacts on human societies are brought by the natural hazards. Some of the most severe disasters are the results of the regular occurrence of geo hazards such as earthquakes, landslides, ground deformation, volcanic eruptions, and tsunamis.

One of typical geo disasters is a sediment related disaster. Landslides, floods, debris flows, and pyroclastic flows commonly cause the sediment related disasters. The definition of sediment related disaster is the disaster generated by movement of soil and rock, which results in direct damage or indirect damage to the people lives and properties, inconveniences to the life of people, and the deterioration of landscape and ecosystem. The sediment disasters take place in many forms, for instances: infrastructures such as houses, bridge and water intake destroyed by mass movement; farmland buried; riverbed aggradation and reservoir sedimentation. Roughly, the types of sediment related disasters are divided into two categories, namely the direct type of sediment disasters and the indirect type of sediment disasters. In the direct type, damage is directly given by sediment movement such as pyroclastic flow, debris flow, landslide, and slope failure. In the indirect type, floods and inundation take place with riverbed aggradation or river blocking due to non uniform sediment transport.

The size of sediment related disaster is not so large as an earthquake, flood, storm surge, or tsunami, but its risk/hazard to human lives is very high because it occurs at multiple locations at same time. As sediment related disaster is commonly

influenced by rainfall, earthquake, soil, topography or other factors (Yoshimatsu and Abe, 2005), naturally, countries that have a heavy storm, a frequent big earthquake, many active volcanoes, and a large area with steep slope are prone to sediment related disasters. Japan, Indonesia, and Nepal are representative countries where the sediment related disasters often occur. In Japan, a total of 12.1 million people is threatened by sediment related disasters (www.sabo-int.org). Nepal in the Himalaya is extremely vulnerable to natural disasters due to its fragile geology, steep slopes, high relief and monsoon climates. In 2002, an intense rainfall event caused devastation due to floods and landslides in major parts of the country. About 427 people were killed, 197 were injured, 53 were missed, 53,196 families were affected, and 19,527 houses were destroyed throughout the country (Paudel *et al.*, 2003).

The damage caused by sediment disasters is well documented, although the number is still underestimated. According to data of Emergency Event Database (EM-DAT) in Centre for Research on the Epidemiology of Disasters (CRED), between 1974 and 2003, about 6,367 natural disasters took place in the world. The report informed that the number of deaths was more than 2 million individuals, 5.1 billion people cumulatively were affected, and 182 million homeless were made. 214 events of the natural disasters related to sediment on this period were reported (Guha-Sapir *et al.*, 2004). Table 1.1 shows ranking of major natural disasters by number of deaths. In terms of the number of fatalities, the rank of the sediment related disasters caused by volcanic eruption and landslide is rather low as seen in Table 1.1. Even if all the flood disaster is considered as the sediment related disasters, the total number of casualties caused by sediment disaster is still low compared with the number of casualties caused by drought or storms. However, the number of casualties due to sediment related disasters shown in Table 1.1 is grossly underestimated due to some reasons. First reason is the international databases are commonly recorded by the primary triggering factor, and not by the hazard that causes the fatalities. For example, the 1999 Venezuela disaster is recorded as a flood with about 20,000 deaths, although landslides in the form of debris flows and mudflows caused most fatalities (Nadim *et al.*, 2006).

Table 1.1 Ranking of major natural disasters by number of deaths reported by EM-DAT, 2003

Rank	Disaster type	All Deaths	Deaths 1992-2001
1	Drought	563,701	277,574
2	Storms	251,384	60,447
3	Floods	170,010	96,507
4	Earthquakes	158,551	77,756
5	Volcanoes	25,050	259
6	Extreme temperature	19,249	10,130
7	Landslides	18,200	9,461
8	Wave/surge	3,068	2,708
9	Wild fires	1,046	574
Total		1,211,159	535,416

(Source: Nadim *et al.*, 2006)

The other reason is several sediment disasters have occurred in regions with low densities/population. Consequently, the impact of sediment disasters has looked at a minimal.

Due to the high rates of urban population growth, especially in developing countries located on active tectonic belts, the number of the population living in hazardous areas influenced by sediment disasters has increased enormously. The most common of sediment disasters are pyroclastic flows, debris flows, and landslides. So these events will be discussed as follows.

(1) Pyroclastic and debris flows

Volcanic hazards are one of the Earth's major natural hazards and have claimed 266,000 lives in the past 385 years (Haraldur and Steven, 1985). Quantifying the impacts and incidents of volcanic phenomena during the 20th Century is shown in Table 1.2 and Table 1.3. Table 1.2 shows maximum and minimum estimation because many references present the different qualitative description for some events. Pyroclastic flows and surges are generally the most hazardous of volcanic phenomena. These density currents of hot gases and particles flow down on the slopes of a volcano at speeds of tens to hundreds m/s. Because of their sudden generation and high velocity, they can reach towns and villages within minutes of their initiation. Hence, it is very difficult to escape from pyroclastic flows. People are generally asphyxiated in the hot, oxygen-poor and dust laden cloud, or

killed by projectiles or skin burn and buried in the resulting volcanic deposit. Pyroclastic flows were the main cause of death (Witham, 2005), followed by primary lahar which is also the principal cause of injuries. Debris flows occur in a variety of forms depending on the conditions of the site and the factors contributing to their occurrence. Debris flows are roughly divided into five types when classified by the contributing factors; namely riverbed sediment movement type, slope failure type, natural dam collapse type, landslide type, and volcanic activity type.

The flow characteristics of debris flows depend on the type, the size, and the concentration of stone grains included in them. If a large amount of coarse gravel and relatively small amount of fine grain are contained, it is called the gravel type of debris flow. In contrast, if a small amount of coarse gravel and a large amount of fine grain are contained, it is called the mudflow type of debris flow. If the amount of clay and silt are especially large, it is called the viscous type of debris flow.

Table 1.2 Quantifying the impacts of volcanic phenomena during the 20th Century

Human consequence	Minimum	Maximum
Killed	78,840	98,293
Injured	12,315	16,096
Homeless	143,559	544,978
Evacuated/affected	4,933,930	6,342,265
Any incident	5,146,460	6,912,032

(Source: Witham, 2005)

Table 1.3 Countries registering ten or more volcanic incidents in the 20th Century

Country	Number of incidents
Japan	102
Indonesia	99
Philippines	36
USA	31
Guatemala	26
Italy	24
Chile	20
Papua New Guinea	16
Costa Rica	13
Mexico	12
Colombia	12
Vanuatu	11
Nicaragua	11

(Source: Witham, 2005)

For example, the disasters associated with pyroclastic and debris flows have occurred in Latin America. Latin America is a region of high volcanic risk due to its geologic setting (Haraldur and Steven, 1985). In this region, there are approximately 270 active volcanoes. The varied activity of Latin America volcanoes produces a spectrum of volcanic hazards, but historically, two volcanic processes that have caused nearly all the human casualties in the region are volcanic mudflows and pyroclastic surges. During the 1968 eruption of Arenal volcano in Costa Rica, pyroclastic flows destroyed two villages and killed 78 people. Pyroclastic flows killed 23 people during the 1929 eruption of Santa Maria in Guatemala.

A large scale of debris flow took place in Izumi city, Kagoshima Prefecture, Japan in July 1997 (www.sabo-int.org). The debris flow caused 21 people dead, 13 injured, 29 buildings damaged and 10.2 ha of farmland damaged. The sediment volume collapsed approximated 166,000 m³ and the sediment about 80,000 m³ flowed down. In 1999, a large scale disaster occurred in multiple places in Hiroshima prefecture, Japan, especially in north and northwestern parts of Hiroshima city. The disasters consisted of slope failures in 186 locations and debris flows in 139 locations. The damage due to the disaster was 31 people death, 1 person missing and 154 houses damaged. In 2001, a debris flow occurred in the southern part of Nias Island, North Sumatra Province, Indonesia. The disaster killed at least 77 people, 95 people were missed, 325 houses were destroyed, seven public facilities were broken, and many thousands hectares of farmland were damaged. A debris flow took place in 2002 in Modjokerto, East Java Province, Indonesia, which killed 32 people. The sediment volume collapsed was estimated at 7,000 m³.

(2) Landslides and slope failures

Landslide is a phenomenon in which part of or all the soil on the slope moves downward slowly under the influence of groundwater and gravity. Since a large amount of soil mass usually moves, a serious damage can occur. If a slide starts, it is extremely difficult to stop it. Slope failure is a phenomenon in which a slope abruptly collapses when the soil that has already been weakened by moisture in ground under the influence of heavy rainfall or earthquake. Because of sudden

collapse, many people fail to escape from it, if it occurs near a residential area, thus leading to a higher rate of fatalities.

Landslides and slope failures are usually secondary disasters caused by such primary natural events as volcanic eruptions, earthquakes, or monsoon rainfalls. However, landslides often cause major disasters on a global scale every year, and the frequency of their occurrence seems to increase. One of the main reasons why the occurrence of landslide disasters increases is a greater susceptibility of surface soil to instability because of overexploitation of natural resources, deforestation, and uncontrolled land use. Furthermore, traditionally uninhabited areas such as mountainous area are increasingly used for recreational and transportation purposes, pushing the borders further into hazardous terrain (Nadim *et al.*, 2006). Although landslides occur more frequently than other major natural hazards, in terms of the number of fatalities from different hazards, their rank is rather low as seen in Table 1.1. Distribution of the casualties by continent, and economic damage due to landslides are reported as shown in Fig 1.1. The number of landslide events in Asia is the largest compared with other continents and it is estimated at 311 events, followed by America and Europe. However, based on the casualties caused by the disasters, the number of casualties in America is highest, and then followed by Asia and Europe. Meanwhile, the number of affected people in Asia and America are very high compared with other continents. In Europe, the damages caused by landslides is highest that estimated at 40,940,000 US dollar per event. In America and Asia, the damages caused by landslides are estimated at 13,383,000 and 6,118,000 US dollar per event.

The example of the landslide and slope failure events are described as follows. A large-scale landslide occurred in Bomi County, Tibet, on April 9, 2000, with a volume of $3 \times 10^8 \text{ m}^3$. Even though, large landslides are very often taking place in southern of Tibet, the landslide is believed as the biggest one in the last 100 years in China, threatening 4,000 inhabitants (Yanjun Shang *et al.*, 2003). On March 26, 2004, gigantic collapse took place in northern caldera wall of Mount Bawakaraeng, Indonesia. The volume of collapsed mass is estimated at 200 to 300 million m^3 . The caldera wall with a height of 700-800 m collapsed, causing tremendous damage to the surrounding area. The event caused at least 32 people killed, 635 cows lost,

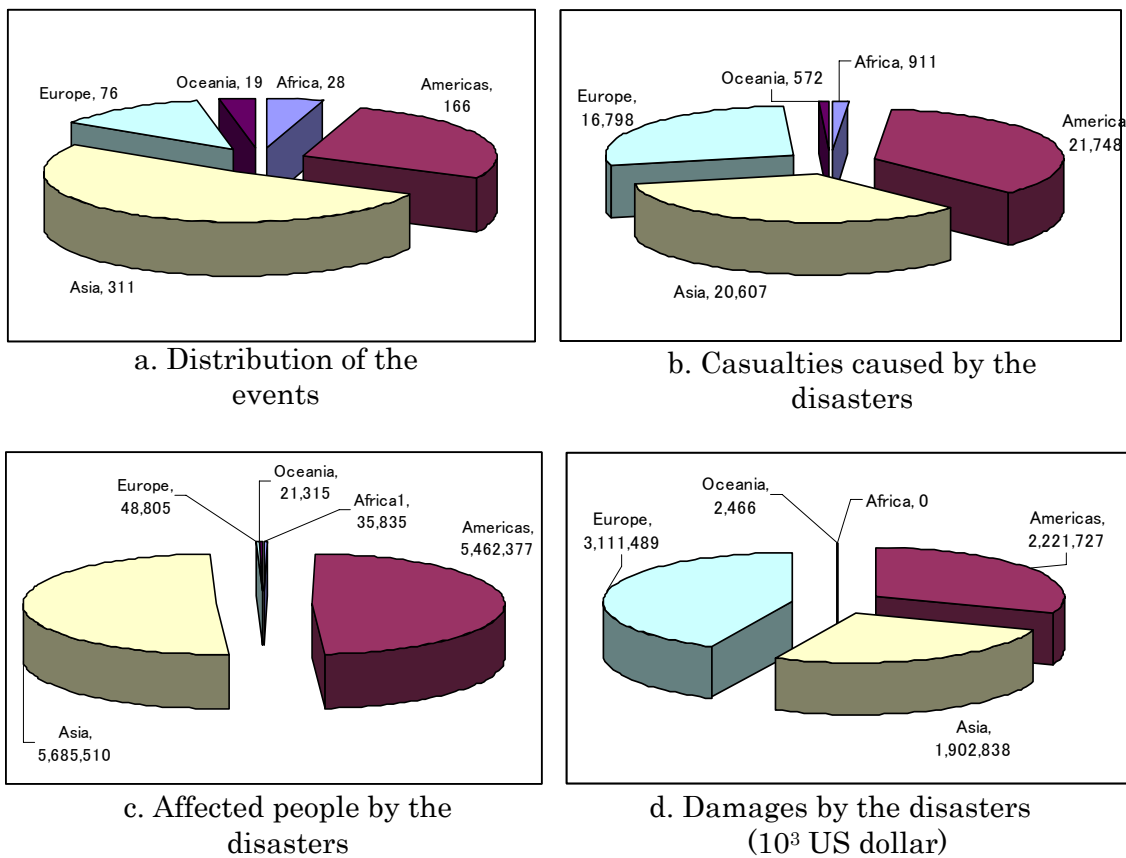

Fig. 1.1 Distribution of the landslide events and its effects on human beings from 1900 to 2010 (Source: CRED, 2010)

and many houses, an elementary school, and about 1500 ha of agricultural land buried. Total damage was estimated at about Rp. 22 billion (Basuki *et al.*, 2010).

1.1.3 Sediment resources

In addition to leading disasters as described in sub-section 1.1.2, sediment also gives benefits to human beings, as the fertile soil and as construction material. The sediment can be used to support the people to get better living. Sand and gravel are widely used as construction material. Highways, bridges, dams, houses, school and so on, all these infrastructures require the use of large volumes of gravel and sand. The demand for aggregate depends on the construction industry, which is closely related to economic conditions. Aggregate demand of government project on infrastructure is a function of funding, which tends to be politically driven. As a

result, the aggregate demand follows the building/infrastructures demand. In 1990, the annual demand of sand and gravel in United States was estimated at 800 million tons (Poulin *et al.*, 1994). The annual consumption of aggregate in Spain is estimated at around 7 ton per person (Taylor *et al.*, 2008). Large amounts of sand and gravel are taken from alluvial fans, marine terraces, flood plains, and channel. However, sometimes the extraction of sand and gravel may conflict with conservation of environment, stabilization of river channels and conservation of recreational functions.

Besides as construction materials, sediment is also needed as resources for the conservation of environment, agriculture land, and beach. Stream channels and their floodplains are economical source of sand and gravel for many purposes, e.g. for construction, road maintenance and so on. However, many researches on sand and gravel mining have shown that in-stream extraction of the sediment can reduce water quality and destabilize channel bed and banks, causing aquatic habitats to be simplified and reducing or eliminating populations of aquatic species.

The link between sediment and the ecology of aquatic systems is very close, but few studies have shown how the relationship between aquatic biota and sediment is. The variety of particle size and bed material structure provides important habitats for different types of aquatic life. The variety is important for providing suitable conditions for spawning, shelter, food sources and so on. For example, salmon requires fine sediment to bury its eggs. Many references have discussed the usefulness of sediments for environmental purposes (i.e. Milhous, 1982), especially for the growth of fish populations.

According to Owen (2008), the functions of sediment as resources for river basin and supporting human life are:

- Sediment is important thing for being and creating aquatic habitats and landforms, as beaches and channel islands,
- Sediment is used for transferring nutrients from terrestrial to freshwater to marine and coastal systems,
- Sediment has functions for coastal ecosystems and the the evaluation of deltas and other coastal landforms, and

- Sediment provides an important natural resource, e.g. aggregates, fertile soil on floodplains etc.

1.1.4 Degradation and aggradation problems

Degradation and aggradation are usually long-term events in riverbed channel caused by natural factors or human interference. If the riverbed elevation decreases, it is called degradation and when the riverbed elevation increases, the phenomenon is called aggradation. If the riverbed elevation does not change at all with time, it is in an equilibrium condition. The both phenomena may cause problems or not, depending on the scale of these phenomena. Degradation and aggradation are very commonly phenomena that occur in many rivers all over the world. Examples of problems caused by degradation and aggradation in some countries are described as follows.

In Korea, many dams have been constructed for multi-purpose projects, such as for water supply, flood protection, and hydropower. Due to capturing sediment, some dams have caused riverbed degradation in the downstream of the dams. The severe riverbed degradation has occurred in many rivers. For example, in the downstream of the Daecheong dam in Keum River, the degradation depth is about 3 m (Woo and Yoon, 2002). On the other hand, the severe riverbed aggradation took place in the lower reach of Han River, and the aggradation depth is estimated at about 10 m. The aggradation has caused many problems on the flood management, deterioration of the aquatic habitat and navigation.

Degradation has occurred in some rivers also in the United States due to some reasons. According to the Report of Federal Highway Administration (FHWA), the riverbed elevation at a location on the South Canadian River tends to decrease in a period from 1938 to 1977, and the degradation depth was estimated at about 3.2 m. Also in California region, degradation took place in some rivers. The riverbed degradation was caused by land conservation (Thorne, 1991), short cutting, and channelized as well as sand mining (FHWA, 1980). Since 1940, natural conditions covered vegetation in some basins has returned. As a result, the sediment yield has been reduced. Due to the channelization in order to increase channel capacity by straightening, enlarging and clearing of vegetation, transported sediment tends to

increase and it resulted in riverbed degradation. The degradation threatens river structures, especially bridge structures.

Commonly, riverbed elevation in Indonesia tends to lower although sediment production increases due to deforestation, land clearing and volcanic activities. In the Bengawan Solo River, the sediment production from its basin is estimated at 3.18 million m³/year (Mukhlisin, 2007). The riverbed degradation is caused by excessive extraction of the riverbed materials. For example, the riverbed of the Brantas River in the East Java has continued to be lower since the 1980s due to the reservoir sedimentation in the upper reach and sand mining in the middle and lower reaches.

1.2 Global Warming Impacts on Sediment Related Problems

Global warming has to get to be well known to many people as one of the significant environment topics of our days. As generally understood, global warming refers to the effect of human activities on the climate, in specific the burning of fossil fuels and large scale deforestation, which give rise to emissions to the atmosphere of large amounts of 'greenhouse gases'. One of the most important greenhouse gases is carbon dioxide. The basic principle of global warming can be understood by considering the radiation energy from the sun that warms the Earth's surface and the thermal radiation from the Earth and the atmosphere that is radiated out the space (Houghton, 2005). If the amount of greenhouse gases increase due to human activities, the basic radiation balance is altered. The balance can be restored through an increase in the Earth's surface temperature. The increase of Earth's surface temperatures were estimated by the Intergovernmental Panel on Climate Change (IPCC) to be between 1.5 and 6° C on the global basis by 2100 (Goudie, 2006).

For the last 140 years, the increase in temperature over the 20th century is particularly striking (Houghton, 2005). Over the last 100 years, the average temperature of the earth's surface has increased by 1.3° F, and the increase is accelerating. The condition will tend to melt snow and ice, and promote greater loss of soil moisture through increased evapo-transpiration. Among the consequences of global warming, scientists predict that warming temperatures will increase the

frequency of major storms. In addition, changes will occur in the amount, intensity, duration, type and timing of precipitation which will affect river flows and groundwater recharge. On global basis, runoff will possibly increase in a warmer world because of a global increase in precipitation. Historical discharge records indicate that global runoff increases by 4% for each 1°C rise in temperature (Labat *et al.*, 2003). Some key changes in hydrological system associated with global warming and their effect to sediment disasters will describe roughly.

Rainfall intensity is a major factor in controlling such phenomena as flooding, soil erosion, and mass movements. Scientists predict that global warming makes heavier rainfall happen frequently. Another impact of global warming is that it tends to be drier at summers and will be wetter at winters. During recent warm decades, evidence exists that rainfall events in a number of countries have become more intense. According to Dehn *et al.* (2000), impacts of global warming are the precipitation pattern and air temperature will change. If heavier rainfall occurs frequently, it means sediment hazards also happen more intensely. Some reports indicate that climate change will bring the scale and frequent of sediment disasters with higher scale and frequency in the future.

Studies of the response of runoff to climate changes have indicated that the volume of runoff is more sensitive to changes in precipitation than changes in potential evapo-transpiration. The effects of increasing precipitation are greatly amplified in those catchments. Some of the main tendencies in runoff occurred in Europe are (Goudie, 2006):

- Increase in winter precipitation and decrease in summer precipitation
- General intensification of precipitation
- Increase in moisture loss through increase in evapo-transpiration
- Less winter snow pack
- Earlier melting of snow pack
- Smaller glacial contribution to summer flow

According to Case, *et al.* (2007), Indonesia has become warmer since 1900. The increase in annual mean temperature is estimated at 0.7^o C as shown in Figure 1.2. Annual precipitation has decreased by 2 to 3 % over the last century in across all of

Indonesia (Case, *et al.* 2007). In spite of this, there is a significant spatial variability. In the southern area of Indonesia, i.e. Lampung, South Sumatra, Java, South Sulawesi, and Nusa Tenggara, the annual rainfall declined. Nevertheless, in the northern area of Indonesia, e.g. Kalimantan and North Sulawesi, the annual rainfall increased. Moreover, there is also a shift in the seasonality of rainfall. The wet season rainfall has increased while the dry season rainfall has decreased in the southern area of Indonesia, whereas the opposite pattern was found in the northern area of Indonesia. The situation will give effect on sediment disaster and resource aspects. In the southern area, the sediment use as a resource tends to increase due to lack of agriculture sector. In the northern area, the number of sediment disaster will increase in the future.

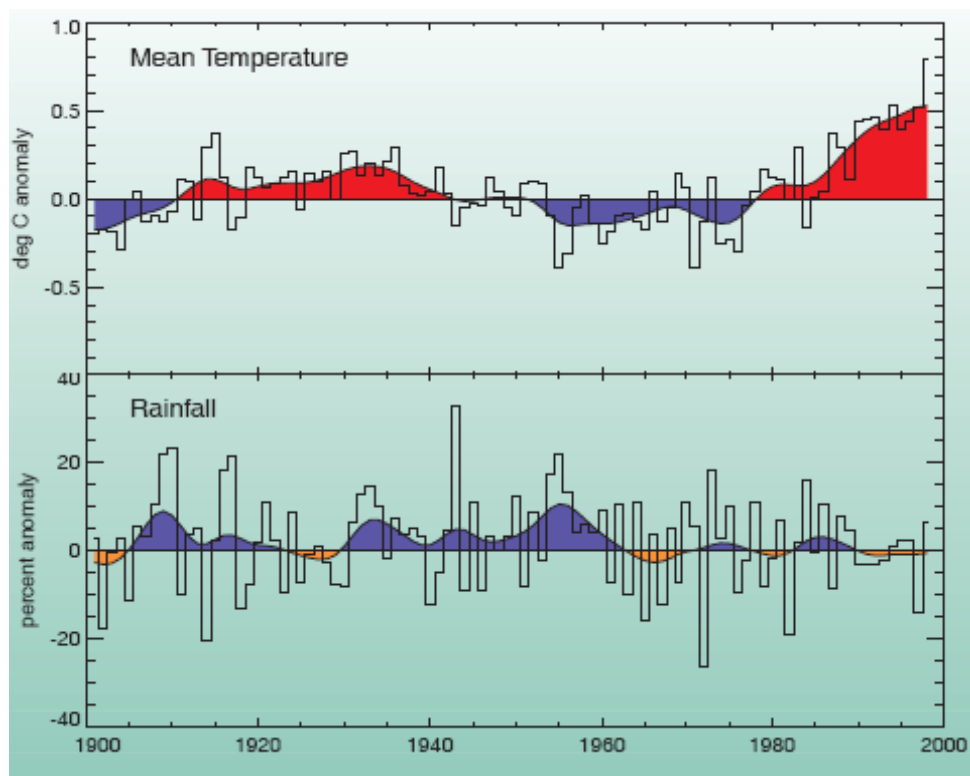

Fig. 1.2 Change in annual temperature and annual rainfall in Indonesia. Adapted from Hulme and Sheard (1999) (Source: Case *et al.*, 2007)

1.3 Sediment Related Disasters and Resources in Indonesia

Indonesia with the total area of 1,919,440 km² consists of more than 13,000 islands, and the coastal line is 54,716 km in length. It is located between Asia and Australia continents, within the Indian and Pacific oceans, and rested on the edges of the Pacific, Eurasian and Australian tectonic plates. Due to its position, Indonesia has high rainfall. The annual rainfall is ranging from 700 to 7,000 mm and the mean annual rainfall is 2,800 mm (Hargono, 2002). Earthquakes frequently occur and cause many landslides. Volcanic eruptions are also very active.

Between January 1900 and March 2009, the Center for Research on the Epidemiology of Disasters (CRED) recorded 93 events involving earthquakes, which caused more than 28,700 deaths (excluding those killed by tsunamis), and directly affected the lives of 5,621,023 others. The economic damage due to earthquakes was about US\$ 4,672,476,000 (CRED, 2009). Although the most common natural disaster in Indonesia is landslides, these events are rarely reported very widely (Legono, 2005). CRED recorded 41 landslide events during the period of January 1900 to March 2009, which resulted in 2236 deaths, affected 393,652 people, and had a negative economic impact of about US\$ 121,745,000.

129 Indonesia's volcanoes are active and volcanic slopes have been densely populated for thousands of years (Lavigne *et al.*, 2008). These volcanoes produce pyroclastic flows, debris flows, and mudflows that cause severe damage in surrounding areas. CRED's Emergency Events Database (EM-DAT) lists 48 disasters associated with volcanic eruptions between January 1900 and March 2009. These events caused 17,945 deaths and had a negative economic impact estimated at US\$ 344,390,000 (CRED, 2009). Millions of Indonesians were directly or indirectly affected by volcanic eruptions. In fact, the number of earthquake, landslide, and volcano eruption is much greater than that recorded in the CRED database because CRED lists only large events.

Naturally, earthquakes, landslides, and volcanoes activities have often produced a huge amount of sediment directly or indirectly. The huge amount of sediment has caused sediment disasters in a short term. However, the sediment is also potential resources. On the other hand, the increasing number of population also has consequences on the land utility. People started logging, cultivating the

land for agriculture as well as land clearing for settlements. Due to the intensive human interference, the land erosion is increasing significantly. In a long term, these situations caused problems such as severe reservoir sedimentation, flash flood and so on. Indonesia is recognized as one of the countries that produces a huge amount of sediment. The categories of sediment disaster in Indonesia by the damage, number of the casualties and affected people are summarized in Figure 1.3. Figure 1.3 indicates that the number of mass movement events is relatively same as the number of volcano eruption events. The number of flash flood events is least, if it is compared to two other events. However, the number of casualties caused by volcano eruptions is highest and it is significantly different, if it is compared with the number of casualties caused by mass movements and flash floods. The number of affected people caused by flash floods and volcano eruptions is also similar. The damages caused by volcano eruption are larger than two other events.

As described above, sediment can provide risks and disasters for human beings. Therefore, from this point of view, it is very important to manage sediment to reduce its risks. However, sometimes the sediment disaster management brings another problem such as channel incision or sediment trapping. In other word, it gives the negative impact to environment. Mass/sediment movement such as pyroclastic flow causes disaster, but it also gives benefit to human beings, making the fertile soil, and construction material. The sediment can be used to support the people to get the better living. However, when people use the sediments as resources, they often ignore its sustainability. Such a situation causes the negative impact for environment and threats public infrastructures such as bridge and water intakes. Therefore, it is necessary to balance sediment disaster mitigation with sediment resources management.

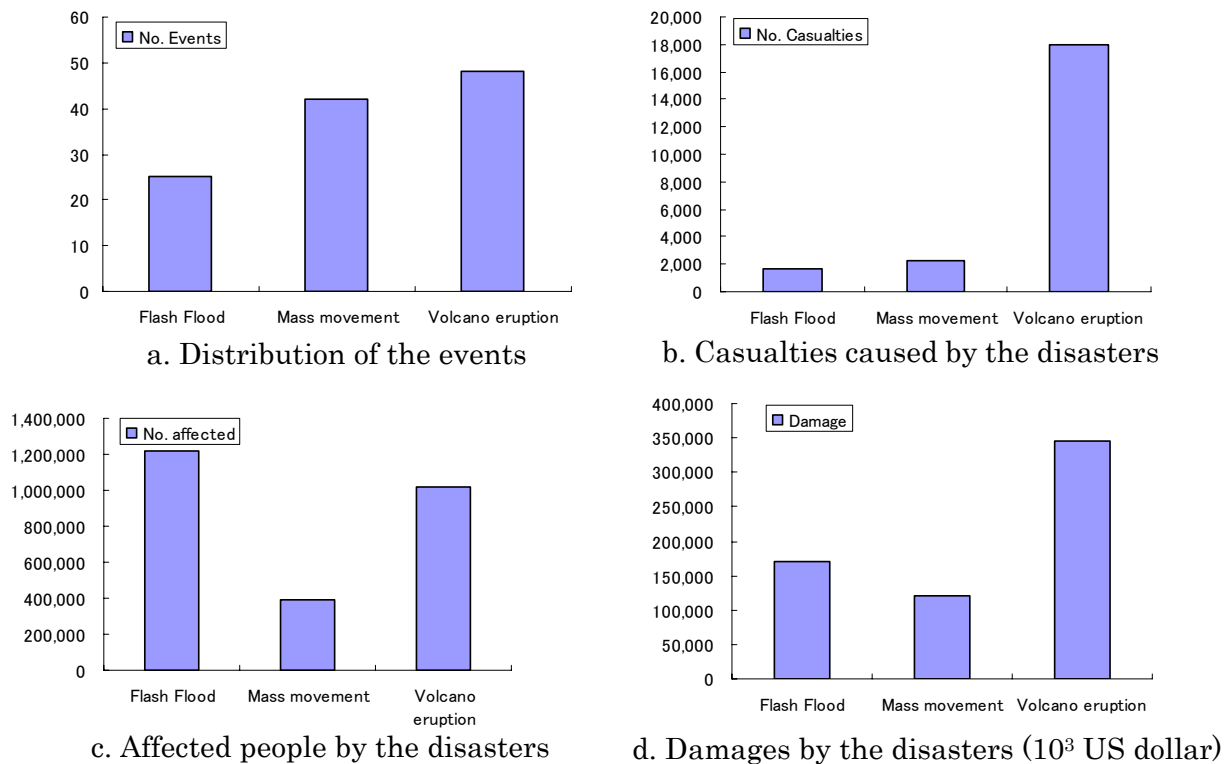

Fig. 1.3 Summaries of sediment related disasters and its effects on human beings in Indonesia from 1900 to 2010 (Source: CRED, 2010)

1.4 Necessity of the Combined Management for Sediment Disaster and Resources

Figure 1.4 shows the relation between sediment disaster management and sediment resources management for sediment movement. Sediment movement is classified into two categories; namely mass movement and individual movement. Landslides, pyroclastic flows, and debris flows are the typical mass movement. Gully erosion, bed load, and suspended load are the typical individual movement. Mass movement causes directly severe sediment disasters as short term events. However the mass movement provides excess sediment resources to the basin. Individual movement also causes sediment disasters such as reservoir sedimentation and bed aggradation/degradation as long term events. Gully erosion is an ordinal sediment production phenomenon and it contributes to potential

sediment resources. Thus, sediment has two aspects and gives both of negative and positive impacts to the basin. The countermeasures are conducted in order to reduce the negative impact. In addition, the sediment resources management is necessary to utilize the positive impact. So far, we have conducted sediment disaster and sediment resources management separately. In fact, the sediment resources management has not conducted aggressively in many countries. However, these two managements should be synchronized very much because there is a close relation between the sediment disaster mitigation and sediment resources management. For example, sediment control facilities for sediment disaster mitigation could affect the sediment resources supply to the basin. Uncontrolled sediment resources utilization results in basin wasting. Weak points for water induced disasters are, therefore, created by the inappropriate sediment resources management. If we conduct sediment disaster management only, people face the problem on sediment resources in future. If we conduct inappropriate sediment resources management, another sediment disaster could be clearly generated. Therefore, the combined management for sediment disasters and resources is necessary.

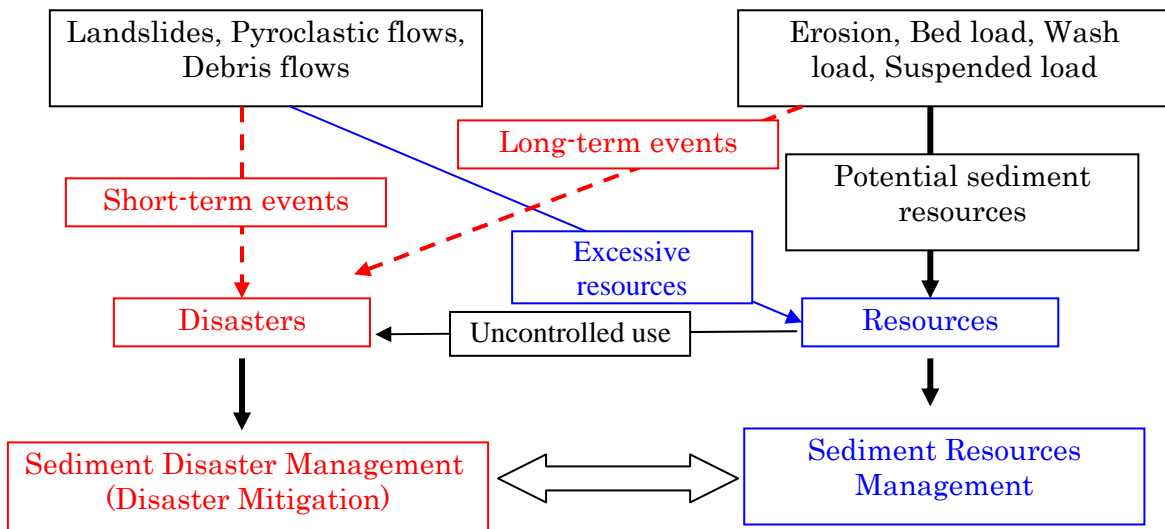

Fig. 1.4 A diagram of two aspects function of sediment, as resources and disasters

1.5 Objectives of the Research

Mount Merapi located in Yogyakarta, Indonesia is one of the most active volcanoes in Indonesia. Figure 1.5 shows the location of Mount Merapi. It has erupted regularly and the eruption has been more active since 1992. Sometime huge eruption occurs and produces tremendous sediment production. The huge sediment production results in severe bed aggradation, pyroclastic flows, and debris flows, threatening people live and assets in the downstream area. Photo 1.1 shows a condition after a pyroclastic event in Mount Merapi. Photos 1.2 and 1.3 describe a situation after debris flow took place in Mount Merapi. On the other hand, the sediment is important resources for local people.

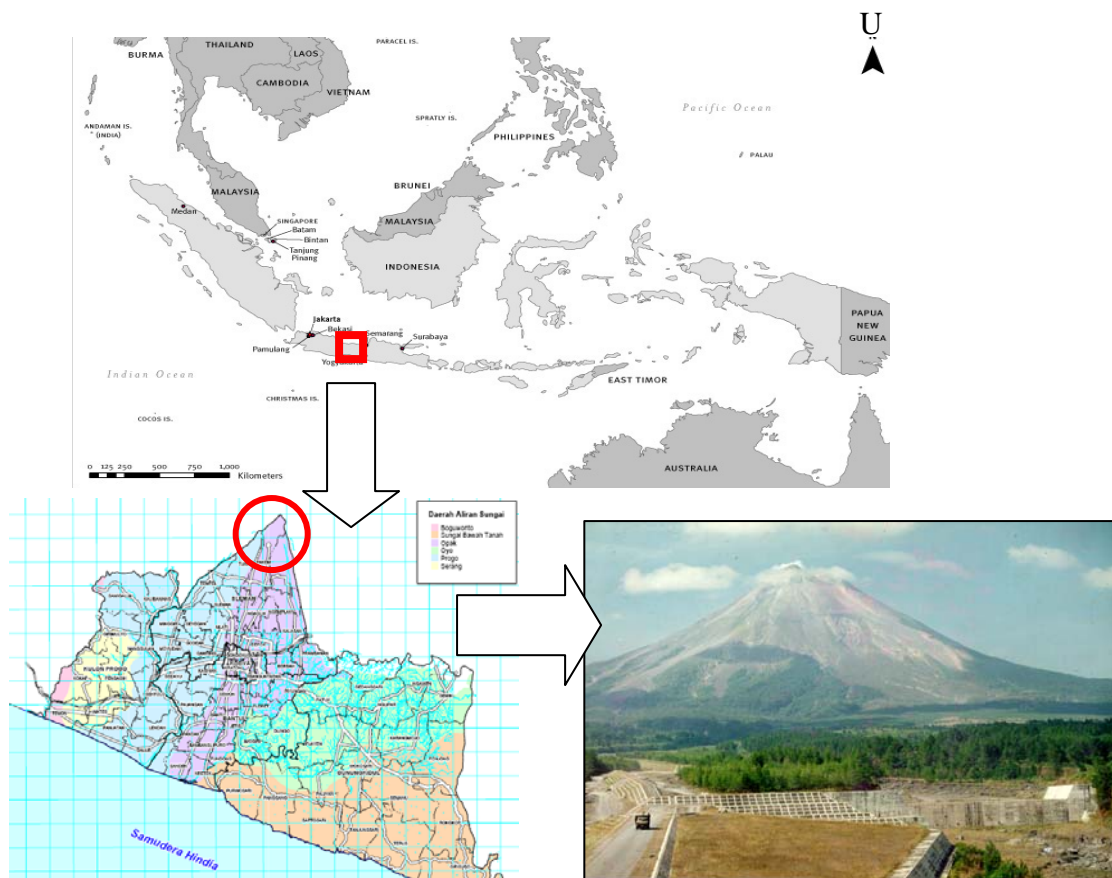

Fig. 1.5 Location of Mount Merapi, Indonesia
(Source: Atlas of Yogyakarta Special Province, 2002)



(a) Before the 2006 eruption



(b) After the 2006 eruption



(c) Kaliadem village after the 2006 eruption

Photo 1.1 Conditions of Gendol River and its surrounding after a pyroclastic flow of the 2006 eruption (Photo (a) and (b) courtesy Adhy Kurniawan, Photo (c) courtesy Yoda Karya)



Photo 1.2 Kemiri Bridge on Boyong River after a debris flow in 1994 (Photo courtesy Adhy Kurniawan)



Photo 1.3 Damages at Kemiri Bridge on Boyong River in 1994 caused by a debris flow
(Photo courtesy Adhy Kurniawan)

The sediment in Mount Merapi has a good quality and is popular as construction material, so that people use it as a resource through sand mining activities. The sand mining activities have given some advantages for rural/local people and local governments. Total number of mining workers in Mount Merapi basin in 2001 amounts to about 21,000 man/day. The local government of Magelang district obtained benefit from the sand mining activities and the district income was Rp 2,218,000,000 in fiscal 1998 (DGWR, 2001). Photo 1.4 shows the sand mining activities on slopes of Mount Merapi. Ban of sand mining damages the economic condition of both local people and local governments. However, uncontrolled sand mining has caused problems in the watershed such as instability of groundsills, bridges and so on due to bed degradation. Especially in the lower reach of the Progo River, bed degradations are observed at 10-30 cm/year. Aquatic and riparian habitats are also destroyed due to natural and artificial armoring. If the sand mining can be controlled, it can be one of measures to prevent sediment disaster and contributes to the rural economy. As described above, it is very important to manage sediment to reduce its risks and to use it as a resource.

Based on the background as described above, this study focuses on the developing a framework of sediment management on volcanic areas considering sediment disasters and resources management, and Mount Merapi basin, Indonesia is selected as a case study.

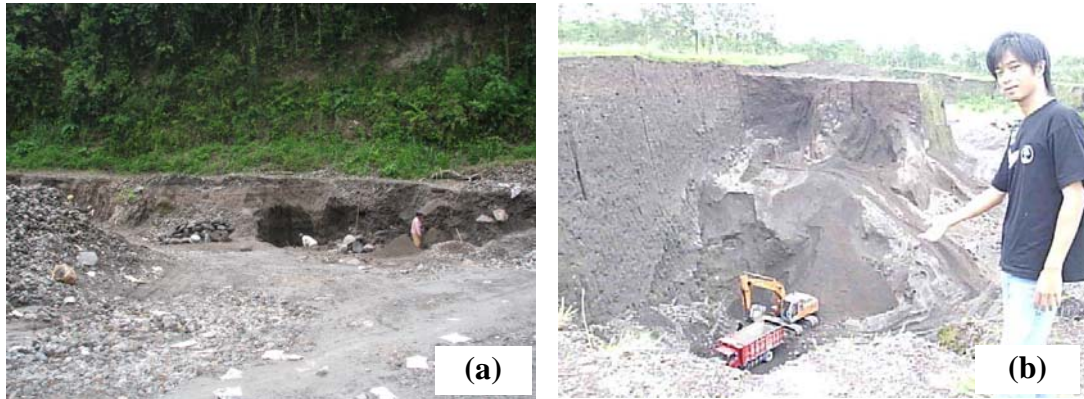

Photo 1.4 A sand mining activity (a) by local people in Gendol River (GE D1), (b) by a company nearby Woro River (Photo (b) courtesy M.Thosan.P)

The objectives of this study can be described as follows:

- a) as a background, this study will figure out the socio-economic and environment conditions in Mount Merapi basin,
- b) developing a concept of sustainable sand mining management,
- c) developing a framework of integrated sediment management, which considers sediment disasters and sediment resources for Mount Merapi basin,
- d) developing a framework to evaluate effect of sediment management from a socio-economic point of view for Mount Merapi basin.

1.6 Thesis Outline

The thesis is composed of five chapters. The synopsis of each chapter is described as follows:

In **Chapter 1**, the worldwide problems on sediment disasters and sediment resources are figured out, as well as the impacts of global warming on sediment related disasters. Then, the sediment related disasters and resources in Indonesia are presented, including the both problems in Mount Merapi basin as the background of this study. The objectives and motivation of this study and the outline of this thesis are also presented in this chapter.

In **Chapter 2**, the socio-economical and environmental conditions in the Merapi area are discussed. To get information of the socio-economical conditions in

the basin, a questionnaire survey for inhabitants and literature investigation are carried out. In addition to socio-economic condition, perceptions of local people as well as representatives of local governments on sediment and environmental issues are also investigated in the survey. The socio-economic aspects such as demography, main industry, and labor force are presented and also current situation of sand mining activities as well as its impact on socio-economic and environment conditions are discussed.

In **Chapter 3**, Mount Merapi activity and current situation of sediment disasters and resources management in this area are described, including the problems that appear in the both management. Then sediment balance in Mount Merapi volcanic basin is discussed. Based on the sediment balance, a concept of sustainable sand mining management is developed. Then a concept of sustainable sand mining management combined with consolidation works is developed as one of the main management in Mount Merapi basin. In this management, the sediment produced at Mount Merapi is used as much as possible with preventing severe riverbed degradation and aggradation. Because the sediment production is not constant, it is necessary to consider the sediment production in huge amount condition. Under these circumstances, the sediment management by means of sabo work, channel works, and sand mining activity regulation is developed. In this study, one dimensional bed deformation analysis is used as a tool accessory for developing sediment management.

In **Chapter 4**, an integrated evaluation method for sediment management is discussed from a socio-economic point on safety, environment, and sediment utilization and the case study of sediment management in Chapter 3 was evaluated by means of this method. To evaluate the effects of the sediment management, some parameters on safety, utilization, and environment have been introduced. From a utilization point of view, job opportunity, additional income of local people and tax income to local government are used to evaluate the effectiveness of the sediment management. The risk degree of river infrastructures was used to describe the effect of the sediment management on a safety aspect. To evaluate the effects of the sediment management on environment, the mean diameter of grain size distribution of riverbed surface is used. On the coordinate system designating these

elements, the direction of change in basin condition by the sediment management can be predicted, so that the most preferable sediment management can be decided. To predict the impact of sediment management on terms of porosity and grain size changes, an experiment and a simulation using a bed-porosity variation model are carried out. Finally, the preferable sediment management in Mount Merapi basin will be developed.

In **Chapter 5**, the results obtained in the present study are summarized and the future perspectives of researches are pointed out.

References

- Basuki, I., Maddi, H.C., Matsunaga, S., and Mizuno, N., (2010), *Effect of Sabo Facilities after Gigantic Collapse in Mt. Bawakaraeng*, Proceeding of Int. Workshop On Multimodal Sediment Disasters Triggred by Heavy Rainfall and Earthquake And The Countermeasures, Indonesia, pp. 1-12.
- Case, M., Ardiansyah, F., and Spector, E., (2007), *Climate Change in Indonesia: Implications for Human and Nature*, www.worldwildlife.org/climate/.../WWFBinaryitem7664.pdf.
- Center for Research on Epidemiology of Disasters (CRED), (2009), *CRED international disaster database*, Universite` Catholique de Louvain, Brussels, <http://www.cred.be/emdat>.
- Center for Research on Epidemiology of Disasters (CRED), (2010): *CRED international disaster database*, Universite` Catholique de Louvain, Brussels, <http://www.cred.be/emdat>.
- Directorate General of Water Resources (DGWR), Republic of Indonesia, (2001), Review master plan study on Mount Merapi, *main report*.
- Dehn, M., Burger, G., Buma, J., and Gasparetto, P., (2000), *Impact of climate change on slope stability using expanded downscaling*, Engineering Geology, 55, pp. 193-204.
- Federal Highway Administration (FHWA), (1980), *Stream channel degradation and aggradation: causes and consequences to highways*, Report No. FHWA/RD-80/038.
- Goudie, A.S.,(2006), *Global warming and fluvial geomorphology*, Geomorphology, 79, pp. 384-394.
- Guha-Sapir, D., Hargitt, D., and Hoyois, P., (2004), *Thirty Years of Natural Disasters 1974-2003: The numbers*, Centre for Research on the Epidemiology of Disasters, UCL Presses Universitaires De Louvan.
- Hargono, (2002): *Sabo, sediment control strategy in Indonesia*, [http://www.nilim.go.jp/lab/bcg/seryou/tnn/tnn0156 pdf/ks0156015.pdf](http://www.nilim.go.jp/lab/bcg/seryou/tnn/tnn0156pdf/ks0156015.pdf), pp 73-78.
- Haraldur S. and Steven C., (1986), *Volcanic disasters in Latin America and the 13th November 1985 eruption of Nevado del Ruiz volcano in Colombia*, Journal Disasters, Vol. 10, No.3, pp.205-216.

- Houghton, J., (2005), *Global warming*, Institute of Physics Publishing, Report on progress in physics, 68, pp.1343-1403.
- Labat, D., Godderis, Y., Probst, J.L., and Guyot, J.L., (2004), *Evidence for global runoff increase related to climate change*, *Advance in Water Resources*, Vol. 27, pp. 631-642.
- Lavigne, F., Coster, B.D., Juvin, N., Flohic, F., Gaillard, J.C., Texier, P., Morin, J., and Sartohadi, J., (2008), *People's behavior in the face of volcanic hazards: perspectives from Javanese communities, Indonesia*, *Journal of Volcanology and Geothermal Research*, vol. 172, pp. 273-287.
- Legono, L., (2005): *Important issues on sediment related disaster management in Indonesia*, International Symposium on Fluvial and Coastal Disaster, Kyoto University, Japan.
- Milhou, R.T. (1982), *Effect of sediment transport and flow regulation on the Ecology of Gravel-bed Rivers*, *Gravel-bed Rivers*, John Wiley and Sons, pp. 819-842.
- Muklishin, M., (2007), *Environmental study on planning of sediment flushing planning in Gadjah Mungkur Dam, Wonogiri, Central Java*, *Proceeding of Water Resources Engineering*, Bandung, Indonesia, pp. 1-10 (in Indonesian)
- Nadim, F., Kjekstad, O., Peduzzi, P., Herold C., and Jaedicke C. (2006), *Global landslide and avalanche hotspots*, *Landslides* 3, Springer-Verlag, pp. 159-173.
- Owens, P.N., (2008), *Sediment behavior, functions and management in river basins*, *Sustainable Management of Sediment Resources: Sediment Management at the River Basin Scale*, Elsevier, pp 1-26.
- Paudel, P.P., Omura, H., Kubota, T., and Morita, K., (2003), *Landslides damages and disaster management in Nepal*, *Disaster Prevention and Management*, Vol. 12, pp. 413-419.
- Poulin, R., Pakalnis, R.C., and Sinding K., (1994), *Aggregate resources: production and environmental constrains*, *Environmental Geology*, 23, pp. 221-227.
- Salomons, W., (2005), *Sediment in the Catchment-coast Continuum*, *Journal Soils and Sediments* 5 (1), pp.1-8.
- Taylor, K.G., Owens, P.N, Batalla, R.J and Garcia, C., (2008), *Sediment and contaminant sources and transfers in river basins*, *Sustainable Management of Sediment at the River Basin Scale*, pp. 83-135.
- Thorne, C.R., (1991), *Analysis of channel instability due to catchment land-use change*, *Proceedings of the Vienna Symposium*, IAHS Publication, No. 203, pp. 111-122.
- Woo, H., and Yoon, B. (2002), *Sediment problems and research in Korea*, *Symposium on River Sedimentation and Morphodynamic Processes Research*, <http://kfki.baw.de/conferences/ICHE/2002-Warsaw/ARTICLES/PDF/315C4-SD.pdf>.
- Witham, C.S. (2005), *Volcanic disaster and incidents: a new database*, *Journal of Volcanology and Geothermal Research*, 148, pp. 191-233.
- www.sabo-int.org, *Basis of sediment disaster*.
- Yanjun Shang, Zhifa Yang, Lihui Li, Da'an Liu, Qiulin Liao and Yangchun Wang, (2003), *A super-large landslide in Tibet in 2000: background, occurrence, disaster, and origin*, *Geomorphology*, Vol. 54, pp. 225-243.
- Yoda Karya, (2008), *Spatial planning project of Mount Merapi basin: final report* (in Indonesian).

- Yoshimatsu, H., and Abe, S., (2005), *A review of landslide hazards in Japan and assessment of their susceptibility using an analytical hierarchic process (AHP) method*, *Landslide*, Vol. 3, pp. 149-158.
- Yogyakarta Special Province, (2002), *Atlas Yogyakarta Special Province: final report* (in Indonesian).

Chapter 2

Socio-Economic and Environment Conditions in Mount Merapi Basin

2.1 Introduction

Human have lived within the shadow of active volcanoes from the earliest periods of social and kinship organization. Volcanoes provide fertile soils, mineral riches, hydrothermal and other resources. However, a volcano eruption gives a cause of a short live inconvenience to normal activity and a cause of massive loss of lives, destruction to rural and urban infrastructures, or destruction of communities (Howes and Minopoulos, 2004).

Indonesia lies between approximately 7⁰ N and 11⁰ S latitudes, and between the 95⁰ E and 140⁰ E longitudes. There are two tectonic plates passing the country, namely the Eurasian plate and the Indo-Australian plate (Legono, 2005), that makes the geography of Indonesia dominated by volcanoes. Indonesia has 129 active volcanoes spreading across the archipelago. The islands of Sumatera, Java, Bali, Maluku, and Sulawesi have some active volcanoes. Some of them are the most famous volcanoes in the world such as Karakatau, Tambora, and Merapi. Mount Merapi is one of active volcanoes in the world and located at the northern of Yogyakarta City on the border between Central Java and Yogyakarta Provinces, Indonesia. It has erupted regularly since 1548. Mount Merapi has been giving volcanic activities, such as eruptions, lava flows, pyroclastic flows, glowing clouds, volcanic ash falls and volcanic debris flows. The volcanic materials were deposited on the slopes of Mount Merapi. The volcanic activities have caused many disasters and the produced sediment has been used as resources for local people.

Until recently, the vast majority of volcano related published work has been concerned with pure research rooted in the earth sciences (Chester *et al.*, 2002). A generation ago, the study of natural hazards and disasters focused on natural impact, human response, and prospect for mitigation, but did not problematic any of

the key concepts involved, even in cross-cultural contexts (Dove, 2008). In spite of the lack of research into the social aspects of volcano related hazards, it is important to increase in undertaking risk assessments and in determining vulnerability of populations (Howes and Minopoulos, 2004).

Disaster mitigation and sediment utilization depend not only on an understanding of physical process, but also on the environment, the socio-economic conditions, and culture of society. Socio-economic condition is one of the important components, which will influence the successful achievement of the sediment management objectives. Sediment management programs must be designed based on not only technical and scientific issues, but also considering social and economic issues (Heise and Apitz, 2007). Local residents have an important stakeholder in achieving effective sediment management. Therefore, their perceptions of sediment-related problems as well as socio-economic conditions must be considered. In this chapter, a result of the questionnaire survey to investigate the socio-economic condition of inhabitants is described and the perception of local people on sediment related disaster and environment condition in the study areas is discussed.

2.2 Questionnaire Survey

2.2.1 Background

The successful sediment disaster management in volcano areas is often affected by public awareness and perception (Howes and Minopoulos, 2004). Accordingly, to accomplish the purpose of sustainable sediment management in a basin, it is important to understand and consider the social aspect of local people/inhabitant as well as the local government. A questionnaire survey has been conducted in the period from April to June 2008. The objectives of the questionnaire survey are as follows:

- 1) to investigate a socio-economic condition of inhabitants in the upper, the middle and the lower zones of Mount Merapi,
- 2) to investigate inhabitant's opinion on environment, sediment related disaster and sediment resources in these zones.

The method of survey is described as follows. The surveyor team went to a selected area and then conducted an interview to a respondent. A respondent is selected based on a random method; it means inhabitant whom the surveyor team met in a selected area is a respondent. However, the category of respondents was also considered, so the respondents are expected to be representative of rural/urban respondent and generation. Photo 2.1 shows the interview process of the questionnaire survey in the lower zone of Mount Merapi.

2.2.2 The survey area and location

The survey was conducted in three zones, namely the upper zone, the middle zone, and the lower zone as shown in Figure 2.1. Circle U1, M1, L1, and L2 are the surveying areas. The survey areas are categorized using slope characteristic, as shown in Figure 2.2. The upper zone, the middle zone, and the lower zone are areas that have slope larger than 3° , from 2° to 3° , and less than 2° . Also the survey areas are included in 2 basins, namely Progo river basin and Opak river basin.

The upper zone is located at an elevation higher than 200 m above the mean sea level. Commonly, the character of the upper zone depicts a rural environment with predominantly agricultural plants. Livestock farming is one of important activity for inhabitants, especially cow and goat husbandry. Due to Mount Merapi eruptions, sediment production in this zone is abundant. Consequently, sand mining industry is active for supporting daily life of inhabitants. Sand mining activity spreads in the tributaries on the slopes of Mount Merapi. In addition, the zalacca plant has become one of important sources for inhabitants in recent years. The middle area consists of two parts, namely urban and rural area. Urban area is located in Yogyakarta city and the surrounding area. In the rural area, agriculture is the most popular for supporting inhabitants. In the urban area, service industry and entrepreneur are the main job for inhabitants. Sand mining activity in the southeastern part of the middle area is very few. In the western part, sand mining is more activated compared with in the southeastern part, depending on the sediment supply from Mount Merapi. The lower zone depicts a rural area, so agriculture is the most popular job for inhabitants. Due to the sediment deposition

area, sand mining in this zone is more active compared with the activity in the middle zone.



Photo. 2.1 The interview of the survey

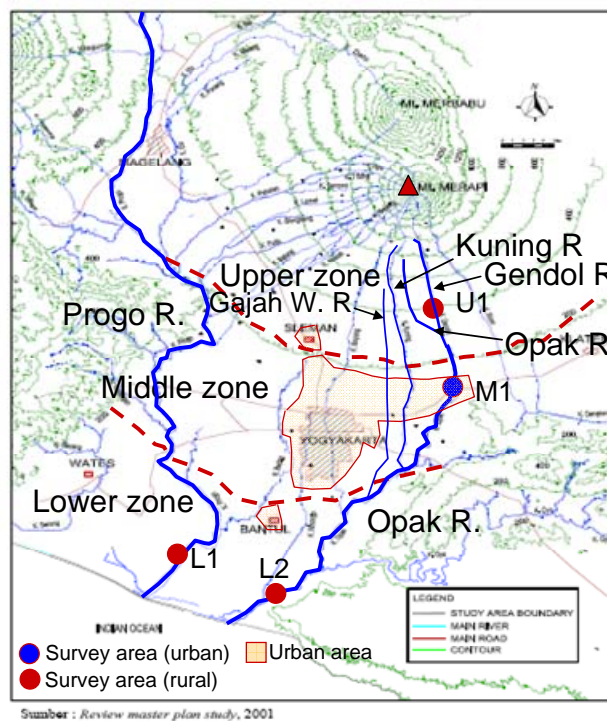

Fig. 2.1 The locations of the questionnaire survey

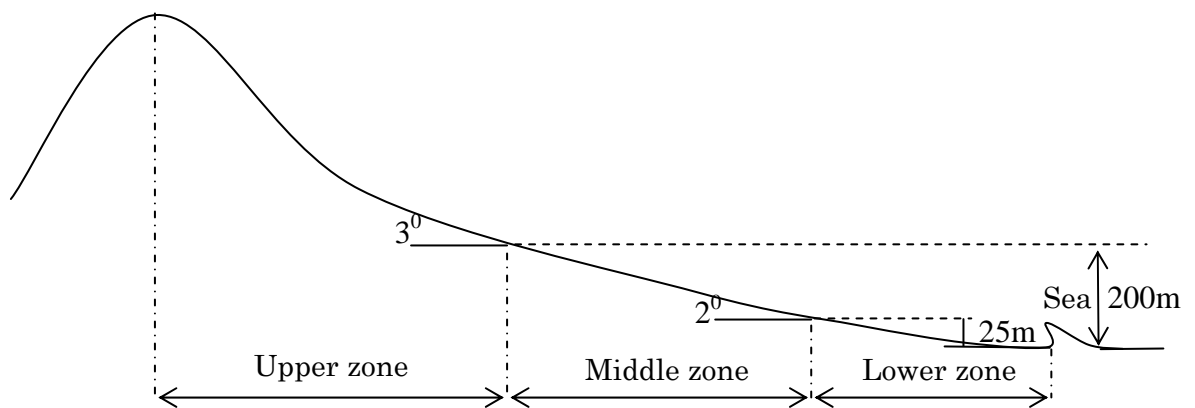

Fig. 2.2 The locations of the questionnaire survey by slopes

Historically, eruptions of Mount Merapi have taken place in the southwestern of its slope. As almost of sediment production from Mount Merapi have flowed down into Progo River, sand mining is very active in Progo River. In the upstream of Progo River, quarry of sand mining is located in almost its tributaries such as Pabelan, Blongkeng, Putih, Batang and Krasak Rivers. In the midstream of Progo River, the sand mining is not so active. However, sometime the activity can be met in this area. In the downstream of Progo River, the sand mining is rather active because sediment is deposited in this area. In the upstream of Opak River, sand mining is conducted in its tributaries such as Boyong, Kuning and Gendol Rivers. In the midstream of Opak River, sand mining is very few due to small resources. In the downstream of Opak River, sand mining is slightly active, especially in location between mouth river and its confluence with Oyo River.

In surveying area U1, the survey is conducted in Cangkringan and Ngemplak sub-districts. The location in the middle zone (M1) is in Kalasan sub-district. Cangkringan, Ngemplak and Kalasan sub-districts belong to Sleman district, as shown in Figure 2.3. As representatives of the lower zone, there are three sub-districts, Kretek sub-district (L2), Srandakan and Galur sub-districts (L1). Kretek and Srandakan sub-districts belong to Bantul district, and Galur sub-district belongs to Kulon Progo district. The distribution of survey locations is shown in Table 2.1 General conditions of the survey area are described as follows.

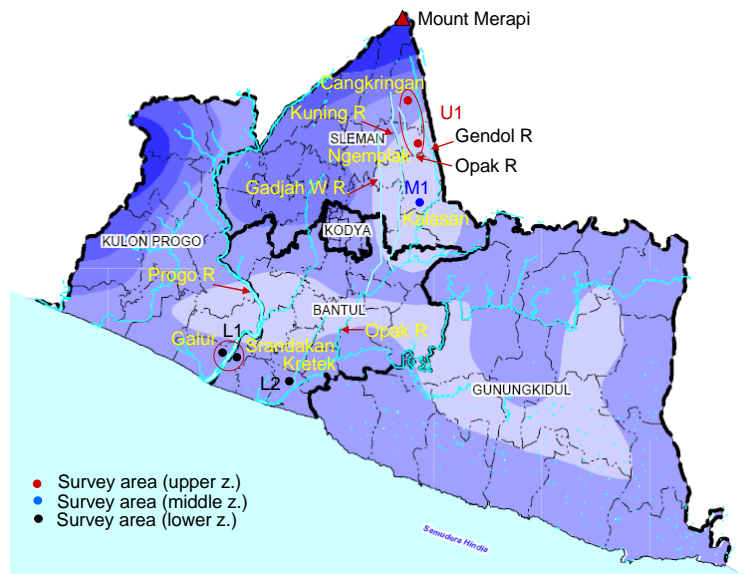

Fig. 2.3 The locations of the questionnaire survey by administrative

Sleman district is one of the five districts in Yogyakarta Special Province. Sleman district is divided into 17 sub-districts. The main sectors in Sleman district are trade, service, industry, and agriculture sectors. The mining in Sleman district consists of class-C material quarrying (sand and stone) from the slope of Mount Merapi.

Cangkringan, Ngemplak and Kalasan sub-districts belong to Sleman district. Cangkringan sub-district lies on elevation range between 442 to 826 m above the mean sea level; the capital of sub-district is located at elevation of 442 m. It consists of five villages, namely Argomulyo, Glagaharjo, Kepuharjo, Umbulharjo and Wukirsari. By year 2007, it covered 4,799 ha, and population density was 583 persons/km². Livestock farming is an important activity for the villagers' livelihood, especially cow and goat husbandry. There are two rivers, namely Kuning and Gendol Rivers, which are the tributaries of Opak River. The sediment resources in this district depend on sediment from Merapi eruption that transported through the both rivers. The deposited sediment due to Merapi eruption in this district is abundant. The total of sand mining group is about 1,242, which spreads in the five villages (Central Board of Statistics of Sleman district, 2007). Therefore, sand

mining is active in Cangkringan sub-district. The location of the survey in Cangkringan sub-district was conducted in Kepuharjo village. The village is located in the upper part of Gendol River basin, at an average elevation of 826 m above the mean sea levels. The area is 875 ha and residential area is 1.06 ha. 902 families and 2,817 people are living by year 2007 (Kamulyan *et al.*, 2010). The total of sand mining group in this village is about 456.

Ngemplak sub-district is located at an average elevation of 275 m above the mean sea level, with the total area of about 3,571 ha. It consists of five villages, i.e. Bimomartani, Sindumartani, Umbulmartani, Wedomartani and Widodomartani. There are four rivers, i.e. Gajah Wong, Gendol, Kuning and Opak Rivers. The four rivers are the tributaries of Opak Rivers. The survey in Ngemplak sub-district was conducted in Sindumartani village. The village is located in the middle part of Gendol River basin. The total area of the village is estimated at 444 ha. By 2007, the population density of the village is about 1,700 persons/km². The variety of agricultural activities is undertaken in the village. The sediment resources in this sub-district depend on sediment transported through Gendol River from Mount Merapi. Sand mining is relatively active, and there are about 120 groups are working.

Kalasan sub-district with the total area of 3,584 ha, consists of four villages, namely Purwomartani, Selomartani, Tamanmartani and Tirtomartani. The population density of the sub-district was estimated at 1,640 persons/km². The sub-district is located along the main road that connects between Yogyakarta and Surakarta. The trade is important activity for inhabitants' livelihood, besides agriculture. The sediment resources in this district are not so much, and it depends on sediment supply from Mount Merapi. The sand mining in the sub-district are not so active; there are only 21 groups, which almost of them are located in Tamanmartani village. In the sub-district, the survey was conducted in Tamanmartani and Purwomartani villages.

Bantul district is divided into 17 sub-districts. The agriculture sector is main source to support economic of Bantul district. The largest contribution in agriculture sector is from the agriculture foods (81.5%), followed by animal husbandry (13%), plantation (3.6%), forestry (0.94%), and fishery (0.93%) (Atlas

Bantul, 2005). Mining in Bantul district consists of sand and stone quarrying from the river, especially in downstream of Opak and Progo Rivers. Sediment resources in Progo River depend on the sediment supply from Mount Merapi. However, sediment resources in Opak River depend on sediment supply from both of Oyo River basin and from Mount Merapi.

Kretek and Srandakan sub-districts belong to Bantul district. Kretek sub-district is located in the downstream part of Opak River basin. Administratively, it is a part of Bantul District. The population density of the sub-district is about 1,184 by the year 2007. The agriculture sector is main activities of inhabitants. The sand mining is active in Opak River, especially in the right edge. Sand mining activity in the downstream of Opak River has grown intensively since many last years. It is more active after the earthquake on May 27, 2006, whereas the sand demand increased.

Srandakan sub-district is located in the downstream of Progo River basin, consists of two villages, namely Poncosari and Tri Murti. The population density of the sub-district by 2007 was estimated at 1,697 persons/km² (Statistics of Bantul District, 2008). Beside agriculture, livestock farming is an important activity for the inhabitants' livelihood, i.e. cow, goat and fowl husbandry. Sand mining in this district is relative intense.

Kulon Progo district is divided into 12 sub-districts. Agriculture sector is main sources for supporting economy of the district. The sediment production in this district is not much, and sand mining activity mainly comprises of sand and stone from Progo River. Galur sub-district, administratively, belongs to Kulon Progo District. It is also located in the downstream of Progo River basin. The main industry for inhabitants in the sub-district is agriculture. Sand mining activity in this district is rather active. The survey locations are summarized in Table 2.2

Table 2.1 Distribution of the survey location

	Upper zone	Middle zone	Lower zone		Total
River	Gendol R.	Opak R.	Progo R.	Opak R.	
Sub-district	2	1	2	1	6
Village	2	2	2	3	9
Sub Village	7	5	10	9	31

Table 2.2 Summarized conditions of the survey locations

No	Location (Village)	Area	Zone	River	Basin	Elevation (m)	Rural/Urban	Activity of sand mining	Industry	Population density (person/km ²)	Population
1	Kepuharjo	U1	Upper	Gendol	Opak	826	Rural	Very active	Farmer (Livestock)	322	2,817
2	Sindumartani	U1	Upper	Gendol	Opak	275	Rural	Active	Farmer	1,258	7,552
3	Tamanmartani	M1	Middle	Opak	Opak	162	Urban	In active	Trade	1,844	13,458
4	Purwomartani	M1	Middle	Kuning	Opak	124	Urban	In active	Trade/Service	1,785	21,625
5	Donotirto	L2	Lower	Opak	Opak	13	Rural	Active	Farmer	1,773	9,399
6	Tirtohargo	L2	Lower	Opak	Opak	8	Rural	Active	Farmer	807	2,924
7	Parangtritis	L2	Lower	Opak	Opak	10	Rural	Active	Farmer	616	7,316
8	Poncosari	L1	Lower	Progo	Progo	9	Rural	Active	Farmer	1,067	12,659
9	Banaran	L1	Lower	Progo	Progo	5	Rural	Active	Farmer	587	5,328

2.2.3 Respondents

Respondents are residents in the villages in the study areas and members of local government, that is a head of sub village and members of village government. The total respondents of local people in the upper, the middle, and the lower zones were 113, 45, and 122, respectively. As the sediment related disasters/problems relatively occurs more intensive in the upper zone and the lower zone, the number of respondent in both zones is larger than in the middle zone. Total respondents of local government are 20 persons. The respondents consist of 86 females and 214 males. Table 2.3 and Table 2.4 show distribution of respondents based on the survey area and the age of respondent.

Table 2.3 Respondent distribution based on the survey location

Area	Upper zone	Middle zone	Lower zone		Local Gov.	Total
	U1	M1	L1	L2	Gendol/Opak	
Female	44	14	11	15	2	86
Male	69	31	49	47	18	214
Total	113	45	60	62	20	300

Table 2.4 Respondent distribution based on the age of respondent

Age (X)	Upper zone	Middle zone	Lower zone		Local Gov	Total
	U1	M1	L1	L2	Gendol/Opak	
X<15	1	1	0	0	0	2
15≤X<30	27	3	24	13	0	67
30≤X<45	53	8	25	20	7	113
45≤X<60	27	27	9	21	12	96
>60	5	6	2	8	1	22
Total	113	45	60	62	20	300

c. Fair

20. What is your opinion about the role of agriculture for supporting economic of resident in the village?

- a. Very important
- b. Important
- c. Fair
- d. Not important
- e. Very not important

C. Perception on Volcano Hazard and Sediment Disaster Prevention Structures

21. What is the year when Mount Merapi erupted in the last time?

- a. 2006
- b. 1998
- c. 1997
- d. 1994
- e. Others (.....)

22. What is the month when Mount Merapi erupted in the last time?

- a. May
- b. June
- c. October
- d. November
- e. Others (.....)

23. What is Mount Merapi hazard that has caused the most damage?

- a. Ash
- b. Gases
- c. Great explosive
- d. Phyroclastic flow
- e. Debris flow
- f. Others (.....)

24. Do you agree that the eruption of Mount Merapi constitutes a disaster for human being?

- a. Very agree
- b. Agree
- c. Hesitant
- d. Disagree
- e. Very disagree

25. Do you agree that the eruption of Mount Merapi has advantages for human being?

- a. Very agree
- b. Agree
- c. Hesitant
- d. Disagree
- e. Very disagree

26. What is your opinion on comparing between hazards and advantages of Mount Merapi eruption?

- a. hazard >> advantage
- b. hazard > advantage
- c. hazard = advantage
- d. hazard < advantage
- e. hazard << advantage

27. How many disasters of volcano eruption did you have in your experience?

- a. < 3
- b. 3 to 4
- c. 5 to 6
- d. 7 to 8
- e. > 8

38. If there were sediment disaster prevention structures, have they been functioned as social facilities, likes as bridge or water intake for irrigation?
- a. Very agree
 - b. Agree
 - c. Fair
 - d. Disagree
 - e. Very disagree
39. In your opinion, what is the main function of a river?
- a. Water resources
 - b. Sand resources
 - c. A place for water drainage
 - d. A place for lahar flowing
 - e. A place for fishing
 - f. Others (.....)
40. What has been the greatest physical change to the river in your village?
- a. Bank River damaged
 - b. River flow change
 - c. Water condition change
 - d. River bed elevation
 - e. Others:
41. Are you sure the riverbed elevation in your village has decreased?
- a. Very sure
 - b. Sure
 - c. Hesitant
 - d. Unsure
 - e. Very unsure
42. Are you sure there are fishes in the river near your village?
- a. Very sure
 - b. Sure
 - c. Hesitant
 - d. Unsure
 - e. Very unsure
43. Are you sure the fish species in the river near your village have decreased?
- a. Very sure
 - b. Sure
 - c. Hesitant
 - d. Unsure
 - e. Very unsure

D. Perception on Impact of Sediment Disaster Prevention Structures on Ecology

44. Do you agree that sediment disaster prevention structures (as sabo dam) can be used to protect habitants from debris flow threats in Merapi volcanic area?
- a. Very agree
 - b. Agree
 - c. Fair
 - d. Disagree
 - e. Very disagree
45. Have the sediment disaster prevention structures been given benefits to protect habitants from debris flow threats in Merapi volcanic area. What is your opinion?
- a. Very agree
 - b. Agree
 - c. Fair
 - d. Disagree
 - e. Very disagree

c. Fair

46. Do you agree that the sediment disaster prevention structures influence the sediment movement in a river?
a. Very agree d. Disagree
b. Agree e. Very disagree
c. Fair
47. Do you agree that the sediment disaster prevention structure is one of causing factors of river bed changes?
a. Very agree d. Disagree
b. Agree e. Very disagree
c. Fair
48. Do you agree that the sediment disaster prevention structures influence fish's movement in a river?
a. Very agree d. Disagree
b. Agree e. Very disagree
c. Fair
49. The sediment disaster prevention structure can influence fish's regeneration in a river. What is your opinion?
a. Very agree d. Disagree
b. Agree e. Very disagree
c. Fair
50. Has the sediment disaster prevention structure been caused the environment damages?
a. Very agree d. Disagree
b. Agree e. Very disagree
c. Fair

Thanks you for your attention and a good cooperation

2.2.5 The results of questionnaire survey

The questionnaire results are presented in the following subsections. The results are summed as percentages and presented as a series of bar charts.

(1) Socio-economic condition of local people

The socio-economic condition of the inhabitants was explored through questions related to education, household job, and family income. The percentage of

education background of respondents under senior high school as shown in Figure 2.4 is 41.6%, 50%, 53.2%, and 62.7% in the lower Progo (L1), the lower Opak (L2), the middle Opak (M1), and the upper Opak (U1), respectively. It indicates that inhabitant education level is still low, especially in the upper area. The education background of government respondents under senior high school is 20%. This educational background condition results in the difference of their perception on sediment related problem.

Figure 2.5 shows the main and additional occupation of householders. Agriculture sector is still as main occupation of households in the lower Progo area (L1); about 51.6 % of households of respondents are farmer, and consecutively followed by entrepreneur sector (20%). About 3% of households of respondents work as sand miner. Almost households in the lower areas have second/additional occupation. Husbandry is popular as additional occupation in this area (33.3%). Sand mining sector is one of additional occupations for inhabitants (8%). In the lower Opak area (L2), the main occupation of households of respondents are farmer (51.6%) and government employer (16.6%). Husbandry is the most popular as an additional occupation for household in this area (40%) and only 8% of households choose sand mining as second occupation. In the middle area (M1), the main occupation of households is entrepreneur (44.4%), and then followed by agriculture sector (17%). Sand mining activity in this area is not so active and only 2.2% of households have sand mining as main occupation. Also it is very few households

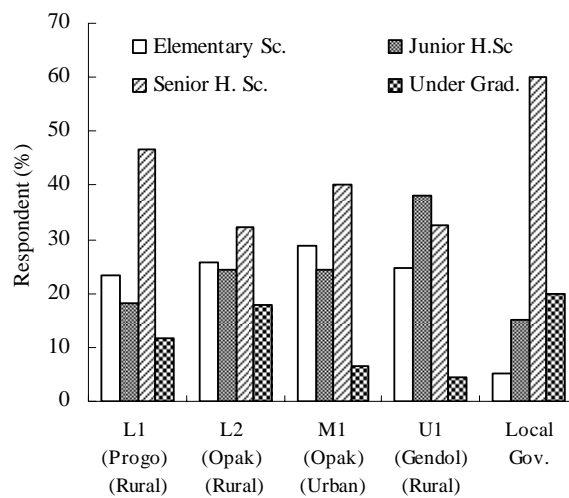

Fig. 2.4 The education background of respondents

have additional occupation in the middle area. Husbandry is the most popular as second occupation for inhabitants in the middle area. In the upper area (U1), the main occupations of households are husbandry (23%), farmer (19.4%) and sand miner (16.8%). Farmer and sand miner are popular as additional occupation for households in the upper area. From Figure 2.6, the occupation of inhabitants in the upper area is dominated by farmer (31.8%), sand miner (27.4%) and husbandry (27.4%). Entrepreneur (46.6%), farmer (20%), and merchant (17.7%) are popular occupation of inhabitant in the middle area, and about of 11.3% of households have occupation as sand miner. Farmer and husbandry are the most popular occupation for inhabitant in the lower area. About 11% of household have activity as sand miner in lower area.

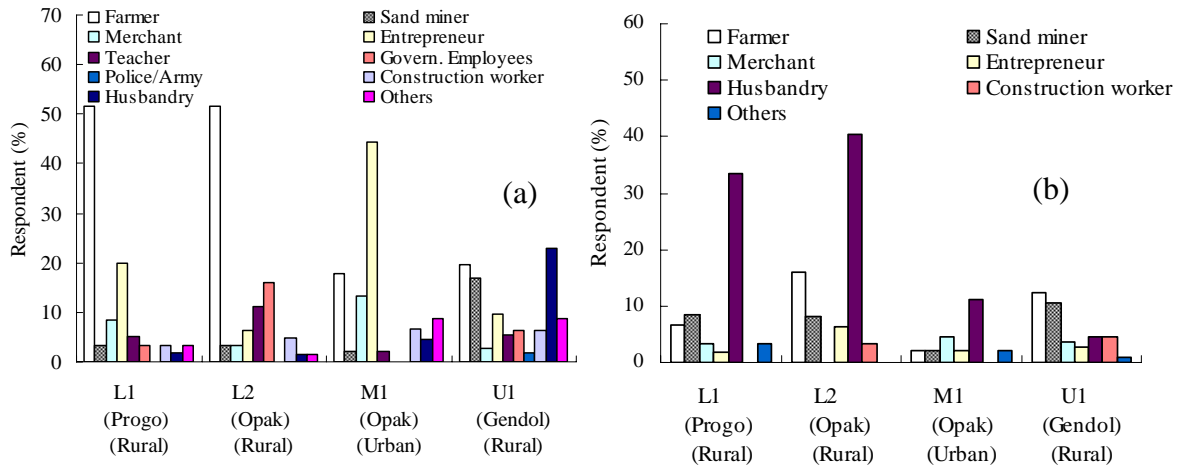

Fig. 2.5 (a) The main occupation and (b) the additional/second occupation of households

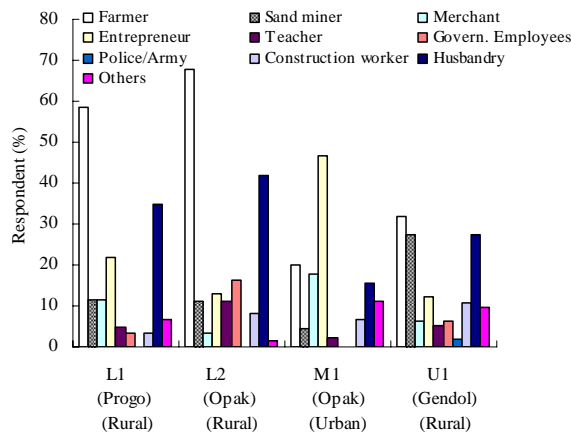

Fig. 2.6 The total percentage of the main and the additional occupations of households

The monthly incomes of households of respondents are shown in Figure 2.7. Compared to the other areas, inhabitants in the upper area have the lowest income. The average incomes of households of respondents are 1.07, 1.17, and 0.8 millions rupiah in the lower (L1) (L2), the middle (M1), and the upper (U1) areas, respectively. It is one of reasons why the sand mining in the upper area to be more active. The result also indicates that people in the urban area have better income than that in the rural area.

(2) Local people’s perception on sediment related problem

In the survey, the local people’s opinions on sediment related problems such as sand mining and its impact were also explored. Figure 2.8 shows that 87.5% and 91.9% of respondents in the upper and lower areas have an opinion that sand mining activity is important for supporting economy of local people, correspondingly. In the middle area, only 22.2% of respondents said that the activity is important for local people economy. The result indicates that sand mining activity is important for inhabitants in the upper and lower areas. Historically, sand mining has become an important activity for inhabitants in both areas to meet the daily needs, because available sediment resources are abundant in the both areas. Unlike in the two regions, the sand mining activity is not so popular for inhabitants in the middle area due to the unavailability of adequate resources in the region. In the upper area, sediment resources are provided by Mount Merapi eruption. Recently, sediment resources in Gendol River are abundant due to the 2006 eruption, because

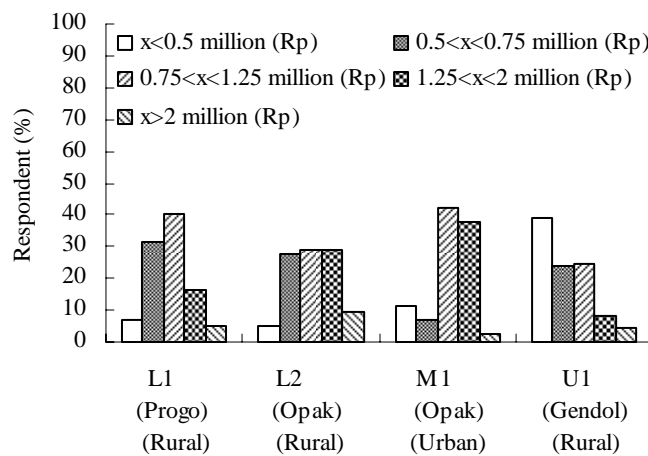

Fig. 2.7 Monthly incomes of households

pyroclastic flows occurred in the southeastern where Gendol River is located. However, the sediment supply could not reach the middle area, so that sediment resources in the middle area are limited.

Figure 2.9 shows the inhabitant's and local government's perceptions on Merapi eruptions. Regarding Merapi eruptions, 80% to 90% of inhabitants in all areas think Mount Merapi eruption provides sediment resources. Inhabitants in the upper area as well as local government have an opinion that Mount Merapi eruption provides sediment resources, but 30 % of them in the upper area do not recognize the eruption as disaster. The reason why they do not care about Mount Merapi eruption as disaster, may be that Mount Merapi activities had influenced on the southwestern and western slopes. Hence, historically, Mount Merapi eruption did not give the negative impacts in this area very much. Another reason is that the local people view the eruptions as agents of change and often change for the good. The result is in line with Dove (2008).

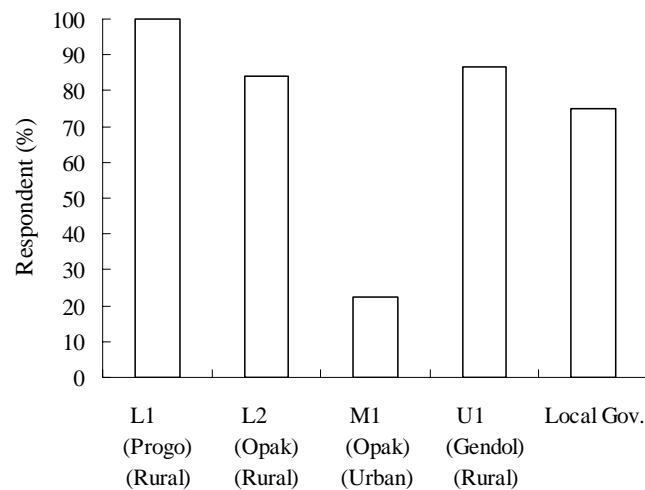

Fig. 2.8 Respondent's opinion on importance of the sand mining activity

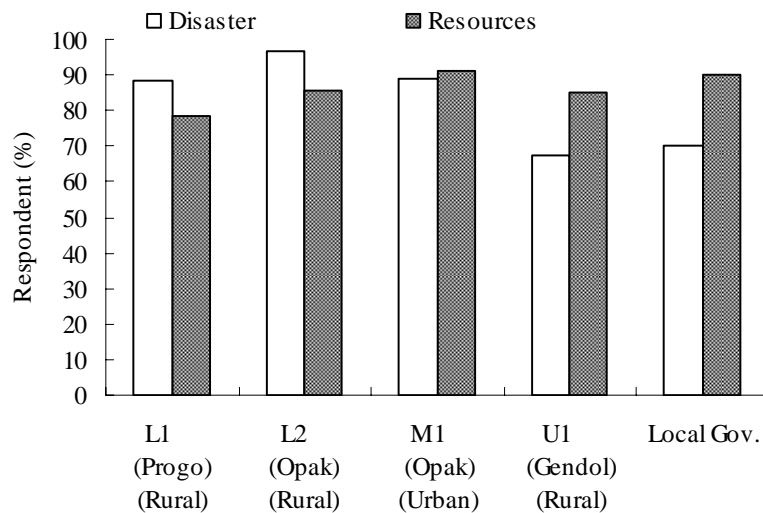

Fig. 2.9 Respondent's opinion on Mount Merapi eruption

In the upper area (U1), the both of debris flow and pyroclastic flow are very popular. So that, inhabitants in the upper area (U1) as well as local government have an opinion that sediment hazard are serious problem for them, as shown in Figure 2.10. Around 30% of inhabitant in the upper (U1) area as well as local government said debris flows have caused serious damage. Percentage of inhabitants in the upper area (U1) and local government who have an opinion that pyroclastic flow is serious problem is 37% and 55 %, respectively. In the middle area (M1), 82% of inhabitants think debris flows are serious problems, because they live in the deposition area of debris flow. In the lower area, only 15% of inhabitants in lower area think debris flows are the biggest problem, but around 40% of inhabitants in the lower area (L1, L2) have an opinion that pyroclastic flows are serious problem. It indicates that debris flow is not so popular. Pyroclastic is huge phenomena, that people even in lower area know the terror trough mass communication.

Figure 2.11 shows respondent's action against sediment disasters. If a disaster occurred in the upper area (U1), almost inhabitants (70%) will evacuate. However, in the middle area (M1) only 20% of inhabitants will evacuate if a disaster occurs. In the lower Opak area (L2) and lower Progo area (L1), percentage of inhabitants that

will evacuate is 30% and 10 %, respectively. Also Figure 2.11 shows that all inhabitants in the three areas always return to their home and most of them do not want to move to another place. For example, although sediment related disasters commonly occur in the upper area, but local people do not want to move to another place. Only about 1.7% of respondents want to move to another place.

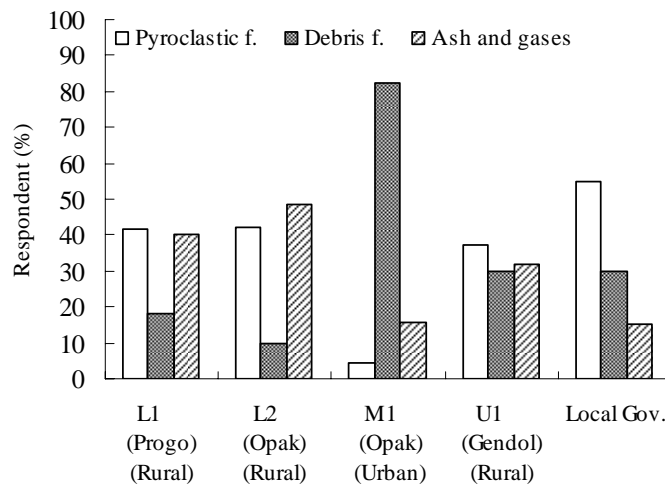

Fig. 2.10 Respondent's opinion on the disasters of Mount Merapi that cause a biggest damage

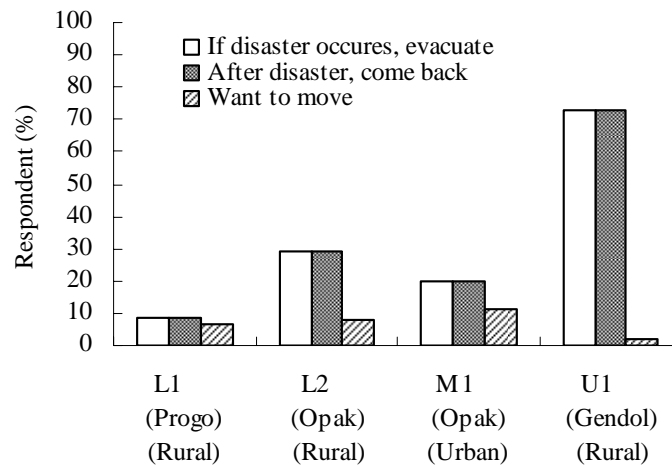

Fig. 2.11 Disaster response of respondents

Figure 2.12 shows the respondent's opinion on river function. Inhabitants in the middle area (M1) as well as local governments have an opinion that river provides water resources. Around 82% of respondents in the middle area and 70% of respondents of local governments said that water resources are the main function of river. 38% to 53 % of local people in the upper (U1) and the lower (L1, L2) areas have an opinion that river has also a function of sand resources. Consequently, sand mining was very active in both areas, although they recognize that riverbed degradation has occurred in the areas, especially in the lower area as shown in Figure 2.13. About 55% to 60% of respondents in the lower area said that riverbed degradation has taken place. Around 30% of respondents of local governments have an opinion that riverbed degradation has occurred. It indicates that local government has also recognized riverbed degradation problem. In the middle area, 75% of respondents said that the biggest problem in river is water quality. It can be understood because the middle area is urbanized. Local governments recognize the water quality problem in rivers. In the upper area, the biggest problem in river is riverbank damage. As sand mining was very active in this area, the activities have given the negative impacts on river environment such as riverbank collapse and riverbed degradation.

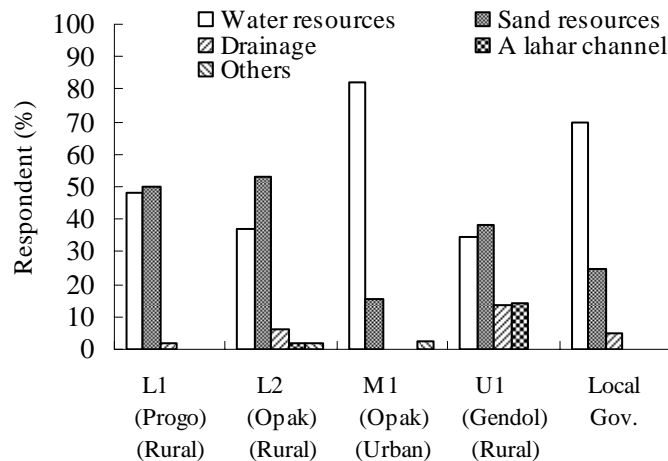

Fig. 2.12 Respondent's opinion on river function

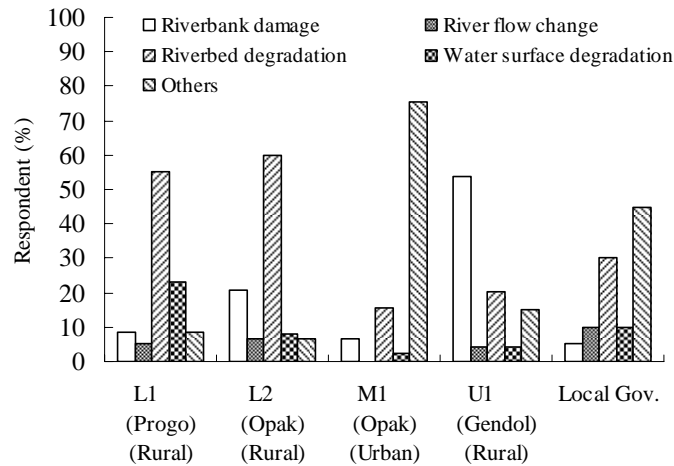

Fig. 2.13 Respondent's opinion on the biggest damage of the river

Sediment plays an important role on habitat formation for fish. From an ecological point of view, changes in the quantitative and qualitative of sediment give an effect on fish population. It is important to investigate respondent's opinion on fish population in river near their houses. Figure 2.14 shows respondent's opinion on riverbed degradation and fish population. Most of the respondents in three areas as well as local governments believe that riverbed degradation has occurred, especially in the lower area. Regarding fish population, 70% to 80% of respondents in the upper and middle areas have an opinion that fish population have decreased. In the lower area, the fish population has also decreased, but it is not so serious comparing in the middle and upper areas. Only 27% to 33% of respondents in the lower area have an opinion that fish population has decreased.

Regarding sabo works, Figure 2.15 shows that almost respondents have an opinion that sabo works including groundsills have given positive impacts to protect inhabitants in Mount Merapi from debris/pyroclastic flows and provide public facilities for them. About 65 % to 90% of inhabitants in three areas have an opinion that sabo works are useful as a social facility. The percentage of local government respondents who have the same opinion is 85%. Figure 2.15 also shows that sabo works have advantages against debris/pyroclastic flows. Around 60% to 80% of

inhabitants have an opinion that sabo works have been useful to protect local people in the upper area from debris/pyroclastic flows. It indicates that they have given a good awareness to sabo works and still need them for disaster mitigations and supporting regional development.

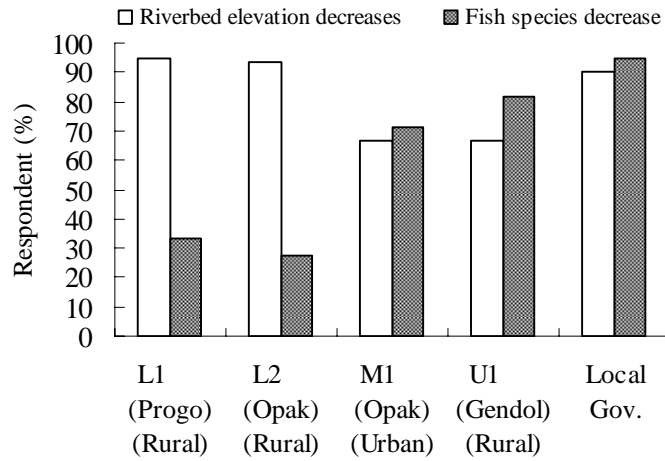

Fig. 2.14 Respondent's opinion on the riverbed degradation and fish population condition

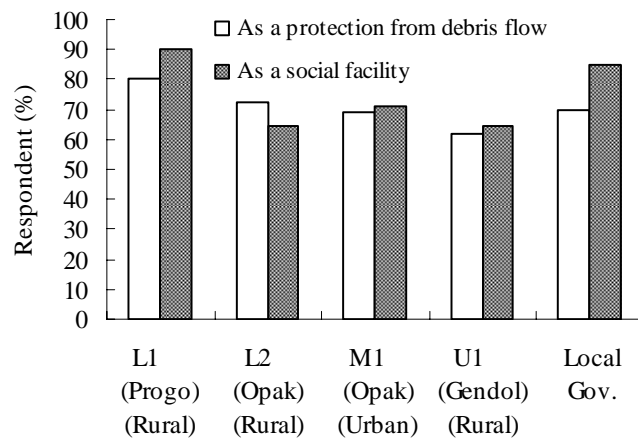

Fig. 2.15 Respondent's opinion on the sabo works

As mentioned above, the survey results are summarized as follows:

- Inhabitant education level is still low, especially in the upper area,
- Agriculture is still one of important industry for local people in the upper and lower areas,
- Sand mining is popular as occupation for households in the upper area,
- Inhabitants in the upper area have the low income,
- Inhabitant in the upper and lower areas have opinion that sand mining activity is important for supporting economy of local people,
- Almost local people do not want to move to another place, although sediment related disasters commonly occur in the upper area,
- Inhabitants as well as local government recognize that riverbed degradation occurred in rivers, especially in the lower area.
- Local people in the upper area need sabo facilities for disaster mitigations and recognize that sabo facilities support regional development such as water irrigation intake and bridge.

2.3 Socio-Economic Condition in Mount Merapi Basin

Socio-economic condition is one of the most important components, which will influence the successful achievement of the sediment management objectives. Study areas in this paper are administrately located in Yogyakarta Special Province and Central Java Province, as shown in Figure 2.16. The study areas cover six districts and one city as shown in Table 2.5. Thus, the socio-economic conditions of the study areas are influenced by the condition of both provinces, especially Yogyakarta Special Province.

Table 2.5 Administrative unit in the study area

Province	District	Density (persons/km ²)
1. Central Java	1. Magelang	1,000
	2. Boyolali	420
	3. Klaten	1,880
2. Yogyakarta	4. Sleman	1,450
	5. Kulon progo	740
	6. Bantul	1,510
	7. Yogyakarta City	15,130

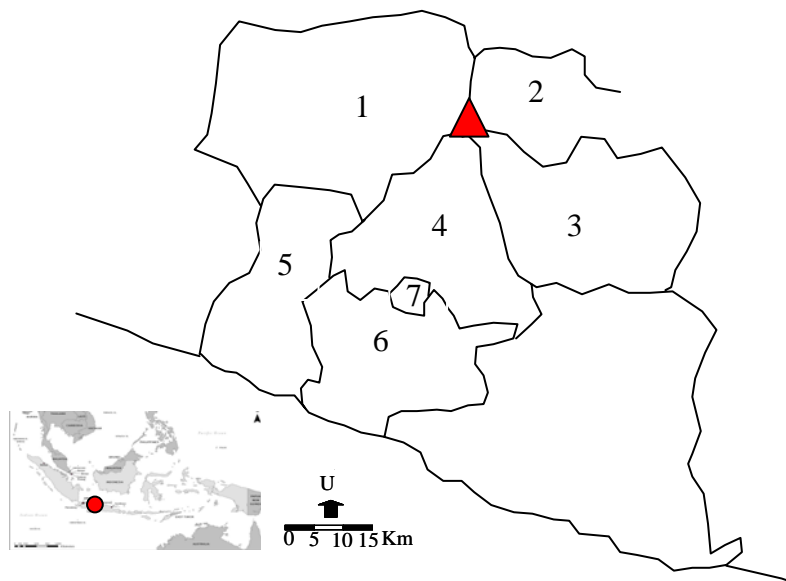

Fig. 2.16 Location of study area; Magelang (1), Boyolali (2), Klaten (3), Sleman (4), Kulon Progo (5), Bantul (6) and Yogyakarta City (7)

2.3.1 Demography

Population in the study areas is estimated at about 2.6 million. The population density as shown in Table 2.5 ranges from 420 to 15,130 persons/km² (DGWR, 2001f). According to investigation from 1980 to 1999, population in the study areas tends to increase. The population growth in Kulon Progo district is the lowest in the study areas because the district consists of mountainous ranges. Densely populated area in Kulon Progo district locates along Progo River from Galur-sub-district in the south to Kalibawang sub-district in the north, where irrigated areas extend. The highest population growth is in Yogyakarta City because of the urban areas, and then followed by Sleman District where the most of the area is threatened by volcanic activities of Mount Merapi. Nowadays, Sleman District has become the advanced region due to regional development. Population growth of Bantul district is estimated at 1.0% and most of population spread in the district area. Bantul is the flat and largest irrigated area in Yogyakarta Special Province. The irrigated area in this district has been introduced since the colonial era.

According to the data from Public Work Agency (2005), the population density in sub-district surrounding Mount Merapi ranges from 558 to 1045 persons/km² and the lowest is in Cangkringan (Ikhsan, *et. al.*, 2009a). The average annual growth of population in the area ranges from 0.7 to 1.3%/year (DGWR, 2001c). Figure 2.17 shows the location of selected sub-districts and circumstance surrounding Mount Merapi. Ngemplak, Sleman and Tempel are sub-districts that are representative as the non mountainous area. The population growth of the sub-districts in Sleman is shown in Figure 2.18. Between 1980 and 1990, the population rate in the mountainous area is lower than the non-mountainous area. During 1990 to 2000, the population rate in the mountainous area is approaching to non-mountainous area. After 2000, the population rate in the mountainous area is almost same rate with in the non-mountainous area. It indicates that the acceleration of population growth in the mountainous area is larger than in the non-mountainous area. The population has increased in mountainous area significantly after 2000. Figure 2.19 shows ratio of population in 2005 to that in 1990 or 2000. During 1990 to 2005, the population in mountainous area has increased about 20% to 30%. In non-mountainous area in the same period, the population has changed around 15% to 25%. Between 2000 and 2005, the population in mountainous area and non-mountainous area has changed about 10% to 20%, and 2 to 12%, respectively. It indicates that the population in mountainous area has increased faster than in non-mountainous area.

The reasons why the population increased fast in the mountainous area are as follows. One of the reasons is the development of infrastructure such as transportation access and irrigation provided by sabo works. In Mount Merapi basin, the sabo works are not only for sediment disaster countermeasures, but also for regional development functions such as a bridge or a water irrigation intake. Second reason is that the area becomes more safety by sabo works. It has encouraged people to move to the mountainous area to use the land and other resources as well as the deposited sediment. According to the survey by JICA (2004) as shown in Figure 2.20, it shows that prior to the project implementation almost half of the respondents were worried about debris flows. After the project implementation, none of the respondents worried about debris flows and 65 % of

them said that they have no fear and live there peacefully. In addition, at least 70% of them said that they get employment and opportunities in sand mining during the agricultural off-season. Moreover, use of agricultural land increased in areas near the sabo dams equipped with an irrigation intake.

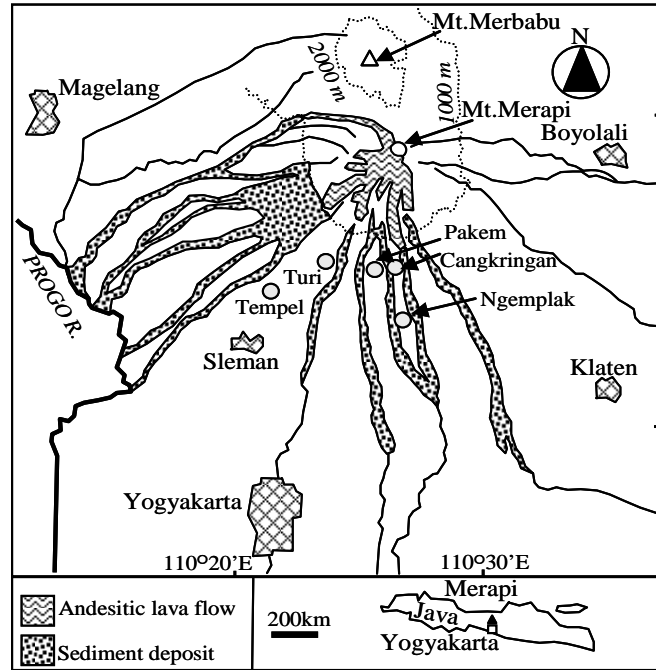

Fig. 2.17 Location of selected sub-districts and circumstance surrounding Mount Merapi basin (modified from Lavigne and Thouret, 2002)

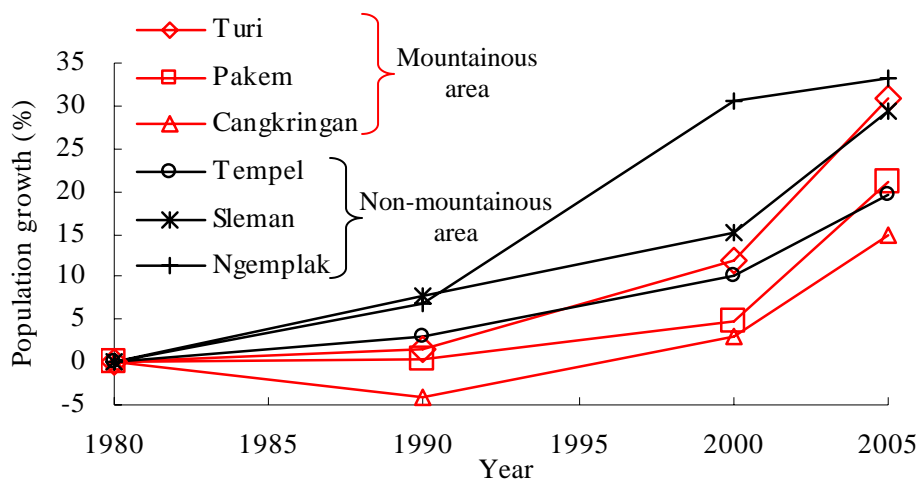

Fig. 2.18 Population growth at selected sub-districts in Sleman district

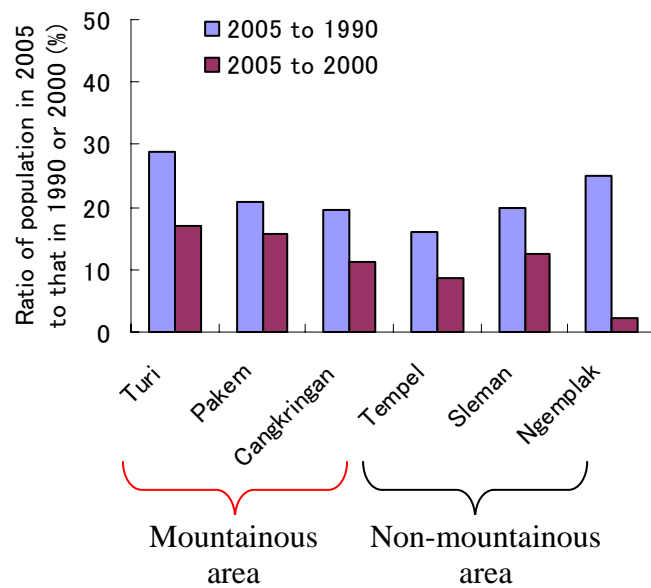

Fig. 2.19 Ratio of population in 2005 to that in 1990 or 2000

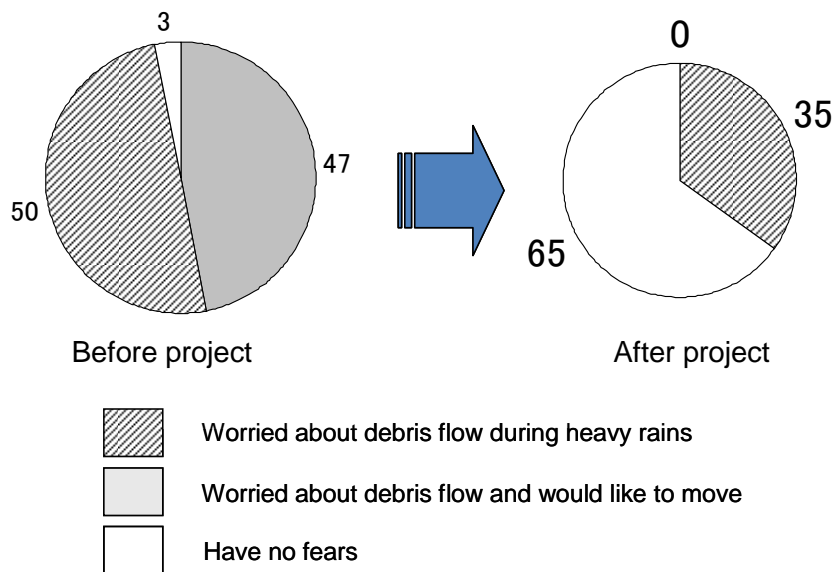

Fig.2.20 Respondent's opinion on sediment related disaster, before and after project

The other reason is that most inhabitants do not have a desire to move to another place. About 7,962 households in villages nearby dangerous zone were interviewed after the 1994 eruption. The result showed that less than 1% expressed any interest in moving/transmigrating. It can be understood because Mount Merapi provides fertile soils, agricultural, mining and tourism benefits. The inhabitants in Mount Merapi basin have adapted to the volcanic environment. They have

developed a system of religious belief, which views eruptions as agents of change and often change for the good (Dove, 2008).

2.3.2 Main industry in the study areas

Gross Regional Domestic Product (GRDP) is one of variables to indicate “weight” of the province or district. Using the data of 2002 for Yogyakarta Special Province and the data of 1998 for Central Java, the contribution of each economic sector to regional development can be analyzed. GDRP of Central Java and Yogyakarta Special Provinces are Rp. 84,267 billion and Rp. 5,358 billion. The agricultural sector dominates the GDRP in both provinces at approximately 25.6% for Central Java and 15.6% for Yogyakarta Special Province (DGWR, 2001c). In agriculture, the product of food crops, such as paddy rice, cassava, maize etc., shares more than 3/4 of the agricultural product, followed by the livestock production. Agriculture remained the leading absorber of the local work force. In Yogyakarta Special Province, agriculture absorbed 46% of total employment in the province. The contribution of mining sector to GDRP in Yogyakarta Special Province is estimated at 1.1%. GDRP per capita of Yogyakarta Special Province and Central Java Province are Rp. 5.215 billion and Rp. 2.745 billion, respectively.

Both provinces are similar in main industries, except service industry. The service industry is relatively important for Yogyakarta Special Province due to its position as one of educational city in Indonesia. Except Yogyakarta city, the main industries of districts are agriculture, industry, trade, and service. The main industries in Yogyakarta city are trade, service, business, and transportation. The percentage of mining industry is around 1% in almost districts, except Magelang district, which indicates that the mining industry is not so important, especially for Yogyakarta city. The percentage of mining industry in Magelang district reached 2.2%, and it shows that the activity is relatively active in the district.

In relation to the economic sector in GDP of Sleman district, the agricultural sector in 2002 was still the fourth biggest contributor (14.0%), after the trade sector (18.6%), service (16.9%), and industry (16.6%). In view of its structure, the biggest sub-sector of the agricultural sector is from the sub-sectors of foods (81.4%), and followed by animal husbandry and its products (8.8%), plantation (4.9%), fishery

(4.3%) and the smallest is forestry (0.5%). Though there is a slight decline in the contribution to Sleman district's economy, this sector is still competent to absorb most labors in almost all sub-districts in Sleman district, amounting to 204,614 persons (48.22%). The contribution of the agricultural sector comes from the five subsectors of foods, plantation, animal husbandry and its products, forestry, and fishers (Source: Atlas Sleman, 2005).

In relation to the economic sector in GDP of Bantul district, the agricultural sector in 2002 remains as the first largest contributor (21.4%). Looking from its structure, the largest contribution from the agricultural sector is the agricultural foods (81.5%), and consecutively is followed by animal husbandry and its products (13.0%), plantation (3.6%), forestry (0.94%) and the smallest is the fishery (0.93%). Even though there has been a small decline in the contribution towards the Bantul district's economy, this sector still absorbs most work forces in almost all the sub-districts in Bantul district with 181,729 people (29.96%) (Source: Atlas Bantul, 2005).

2.3.3 Labor forces

According to the DGWR (2001c), 40%-70% of the population in the study areas is engaged in the agricultural sector, except Yogyakarta city. About 57% of the population in Sleman district work in the agriculture sector that relatively needs only a low-level education and skill. Most people in the Yogyakarta City work for the service sector, such as industry, construction and merchant sectors. The population of Bantul and Kulon Progo districts that works in the agriculture sector is 58 % and 73%, respectively. It indicates that the agriculture sector is still the important activity for people in the study areas.

Generally, inhabitants in Mount Merapi basin are farmer and husbandry as well as sand miner. They usually cultivate maize and tubers, and graze cattle on open rangelands. The agriculture income is actually not enough for daily life due to the small field. The ratio of those small-scale farmers amounts to 91%. Consequently, most of them live under poverty condition. To fulfill the daily basic requirements, almost all householders have second job as sand miner or other jobs. The mining activities become the main livelihood of inhabitants who live nearby

main rivers. In Kemiren village that lies on the southwest part of Mount Merapi slope in the Bebeng River Basin, sand mining activities have become a main job for inhabitants of Kemiren village and from outside of the village. Also, in Kepuharjo village that lies in the upper part of Gendol River, the mining activities are the main livelihood of inhabitants (Kamulyan *et al.*, 2010). The sand mining activities absorbs 49.5% of labor force of Kepuharjo village, as main and secondary occupation. However, recently the economic conditions of inhabitants increase. They had previously cultivated annual food crops for their own consumption, now they produce them for market sale. These include grasses, fruits, fuel woods, milk and meat as well as volcanic sands. The increase in inhabitant income is shown in improvements in housings, which equipped with glass windows, masonry, flooring, and electricity (Dove, 2008).

2.3.4 Current situation of sand mining

Sand, gravel, and other materials produced by Mount Merapi eruption are transported through the tributaries that originate at Mount Merapi, such as Pabelan, Blongkeng, Putih, Batang and Krasak Rivers in west part, and Boyong and Woro in south part. The sand mining in Klaten District has been carried out long time ago, so that there are many ex mining locations. Inhabitants have used private lands as sand resources. As sediment was supplied to Woro River from Mount Merapi after the 2006 eruption, sand mining activity in Woro River became more active. The location of sand mining activity in Sleman District is in Tempel, Turi, Pakem and, recently the main location is in Cangkringan, along Gendol River after the 2006 eruption. Sawangan, Dukun, and Srumbung are the locations of sand mining of Magelang District. Due to unsustainable management, Mount Merapi environment has been threat. Commercial company has mined the sediment deposits exploitatively at a rate of $5 - 6 \times 10^6 \text{ m}^3/\text{year}$. The sand mining location is not only in the stream channel, but also in the land, including the forest conservation area. Such a condition will create increase in erosion and sediment discharge in wet season, and produce another sediment disaster.

(1) Sand mining volume

Based on the data from DGWR (2001b), the average of sand mining volume in the upper reaches of Merapi volcano is amount 25,687 m³ /day and if assuming 20 workable days a month, the annual sand mining volume is estimated at 6.16 × 10⁶ m³/year. 43% of the total volume of sand mining is quarried out of Putih River. The annual volume of sand mining in 1997 and 1998 are estimated at about 3 x 10⁶ m³ and 5 x 10⁶ m³, respectively. Compared to annual volume in 1997 and 1998, the sand mining volume is significantly increased. 88% of the total volume of sand mining is taken out of four rivers, namely Putih, Batang, Krasak and Woro Rivers. The sand mining activity is not only active in the upper reach, but it is also active in the lower reach, especially in the lower reach of Progo River. The annual sand mining in the Lower Progo was estimated at about 2,933 m³/day or 1.07 million m³/year (Indra Karya, 1999).

(2) Location of sand mining activities

As explained above, sand mining activities take sediment out of the tributaries in Merapi area and also in the lower area, especially in the lower Progo and Opak Rivers. To protect river against the sand mining exploitation, Indonesia government given the guidance by Directorate of Water Resources Decree No. 176/KPTS/1987. The decree consists:

- a) Recommendable exploitation locations are a stretch of river with aggradation/sedimentation area, inner curves, and sand pockets,
- b) Un-recommendable exploitation locations are at degradation area, outer curve, riverbank, and at between 500 m upstream and 1,000 m downstream from an existing structure,
- c) Depth of excavation depends on the type of material, thickness of deposits and river topographic conditions and,
- d) Exploitation by heavy equipment shall be considered and depends on type of materials, excavation volume, river topography, and allowable depth of deposits.

(3) Sand mining impacts

a) Employment in the region

Total number of sand mining workers at the foothills of Mount Merapi amounts to about 21,022 persons/day and 20 % of them are woman. They consist of driver, co-driver, loading workers and workers for excavation in the quarry. Generally, for one truck, workers consist of one driver, one co-driver and three loading workers. This condition indicates that sand mining activities have contributed to give employment opportunities and additional income for local people. The relation between numbers of sand mining workers and the amount of production is not simple. The geographical condition is one factor that influences the production because whether the machine method can be used or not is dependent on the condition. For example, in the upstream of Woro and Gendol rivers, sand mining activities use a manual method. The machine excavation method is difficult to conduct because the sites are surrounded by high steep riverbank (70-80 m height).

b) Economical impact

Based on the data from DGWR (2001c), the amount of transaction of four markets (Magelang, Semarang, Klaten and Yogyakarta) is estimated at Rp 1.1 billion/day or Rp 416.4 billion/year. Semarang and Magelang dominate in terms of volume and daily sale. The average market price of one m³ sand is from Rp 30,000 to 55,000 and it depends on the location. The price is highest price in Semarang city and the lowest in Klaten district.

c) Social and environment damages

The negative impacts of sand mining activity are the noise and dust in the quarries and the surrounding area, especially if the activities are done in night, and the damage to the rural road due to overload of trucks along the sand transportation route. The other impacts are collapse of riverbank and armoring in the riverbed in the downstream. Sand mining sometimes destroys ecosystem.

d) Riverbed degradation

Due to the excessive sand mining, riverbed degradation problems appear in Mount Merapi basin. The riverbed degradation occurs in the upper and lower reaches of the rivers, and the most serious problem of bed degradation clearly exists in Progo River. The riverbed degradation occurs in the lower Progo River and causes unstableness of existing river structures such as sediment control dam, bridge foundation and irrigation intake. In April 2000, one of the bridges, Srandakan Bridge located in lower Progo River collapsed. In the upper area, risk of check dam collapse is increasing because of excessive sand mining.

2.3.5 Sediment disaster in the upper area

As described above, Mount Merapi has large amount of natural resources that appeal for the people, so that Mount Merapi region becomes the society concentration point. On the other hand, recently, Mount Merapi erupts more frequently, and the eruptions have induced pyroclastic flows due to the collapse of lava dome or lava tip giving disasters in the downstream region. A tremendous amount of volcanic loose sediment is deposited on the slopes of Mount Merapi. The loose deposit flows downstream as the debris flows when there is an intensive rainfall. It means the number of people threatened by sediment disasters is increasing. Moreover, the sediment disasters endanger the downstream villages, assets, and social infrastructures. Many facilities in the foothills of Mount Merapi have been damaged by sediment disasters, creating the negative impact on agriculture in the surrounding region.

2.4 Environment Condition

2.4.1 River systems

Mount Merapi basin has 3 river systems, specifically: 1) Progo River system, 2) Opak River system and 3) Woro/Dengkeng River system. Figure 2.21 shows the river systems in Mount Merapi basin. Table 2.6 shows the summaries of main characteristic of those rivers.

Table 2.6 River systems in Mount Merapi basin

River systems	Catch. Area (km ²)	Length of Main Channel (km)	Average slope			Width (m)	
			Under El. 500 m	El. 500 m to 1000 m	Over El. 1000 m	Min	Max
1. Progo R.	2,380	140	1/210	1/60	1/6	150	800
a. Pabelan R	110	32	1/53	1/21	1/3	10	180
1) Apu R	8	6	-	1/14	1/4	10	100
2) Trising R.	10	11	-	1/17	1/5	10	120
3) Senowo R.	8	12	-	1/19	1/4	10	130
b. Blongkeng R	68	24	1/43	1/19	1/1	10	120
1) Lamat R	14	19	1/38	1/21	1/2	10	110
2) Putih R	26	23	1/39	1/16	1/6	10	200
c. Batang R	23	19	1/37	1/15	-	10	230
d. Krasak R.	34	27	1/26	1/17	1/16	10	250
1) Bebeng R	10	14	1/23	1/15	1/5	10	280
2. Opak River	1,250	70	1/100	1/13	1/8	10	700
a. Boyong R.	51	25	1/46	1/14	1/4	10	160
b. Kuning R.	45	17	1/38	1/16	1/4	10	150
c. Gendol River	14	32	1/37	1/15	1/4	10	200
3. Woro River	22	25	1/35	1/14	1/3	10	500

(Source: Directorate General of Water Resources, 2001a)

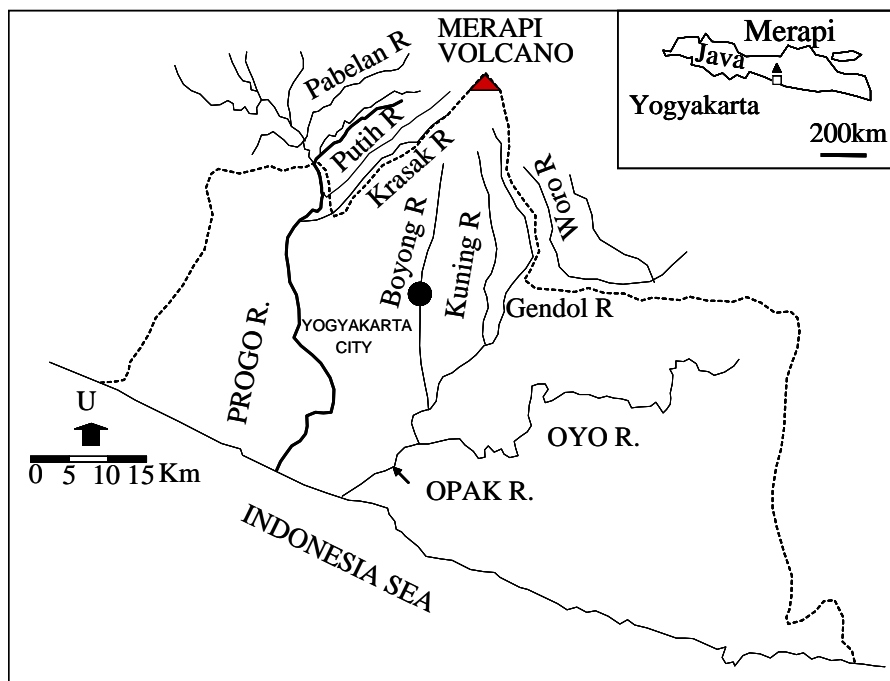

Fig. 2.21 River systems in Mount Merapi basin

(1) Progo river system

The Progo River system is located on the west slope of Mount Merapi. The tributaries of Progo River potentially supplying water to the main river are Pabelan, Blongkeng, Batang, and Krasak Rivers. Each of the tributaries has an average discharge of 0.7-1.0 m³/s (Santosa and Sutikno, 2006). Due to such a condition, it contributes to the character of Progo River as a perennial stream, which is always flowing all over the year with an annual average discharge of 83.1 m³/s.

Progo River flows through the Central Java Province and Yogyakarta Special Province, and has a catchment area of 2,380 km². The catchment area includes the slope of Mount Merapi with an area of 620 km² equal to 26% of the total basin area of the Progo River. The river with a total length of 140 km originates at Mt Sumbing, Ngadirejo, Temanggung district (Sarwono, 2002) and drains into the Indonesia ocean. People have used the water from Progo River for daily lives, mainly for irrigation. The river water flows along the foot of four volcanoes i.e. Mount Sundoro (3,136 m), Mount Sumbing (3,240 m), Mount Merbabu (3,142 m), and Mount Merapi (2,986 m), as shown in Figure 2.22



Fig. 2.22 Progo River basin and Opak River basin
(Source: Google Earth, 2008)

The Progo River basin can be divided into 2 groups, explicitly the river basins unaffected (Upper Progo) and affected (Lower Progo) by Mount Merapi eruptions. The upper Progo consists of Progo River and Elo River up to their confluence. Even though the amount of carried sediment has increased due to the deforestation in the upper area, the rivers unaffected by Mount Merapi carry relatively constant sediment. The rivers affected by Mount Merapi carry a heavy sediment load after its eruptions, from the confluence of Pabelan River to the river mouth. Sediment supply increases after an eruption, and if the stream cannot carry away it, sediment deposition occurs.

The sediment products of Mount Merapi come into Progo River in the downstream of the confluence with Elo River. In the main stream, sometimes the sediment is deposited, but the river water usually transports the sediment to downstream because of rather steep slope (1/100). A large amount of sediment can be transported and then deposited at the downstream of Progo River, in the downstream confluence with Krasak River.

The bed slope of Progo River from 110 km upstream of river mouth to the confluence of Pabelan River is about 1/160 and river width is about 70 m on average. The river becomes steeper in the downstream of the confluence of Pabelan River up to confluence of Krasak River. The average bed slope is 1/100 and the river width is from 50 to 100 m. In the lower reach, particularly in 20 km upstream section from the river mouth, the river becomes very mild and wide. The bed slope is 1/600-1/700 and the width is 400-700 m.

(2) Opak river system

The Opak River originates at Mount Merapi as shown in Figure 2.22. Boyong, Kuning and Gendol Rivers are tributaries of the Opak River system, which are located on the southern slope of Mount Merapi. The average discharge in each tributary ranges between 0.5-1 m³/s. The main river flows into the Indian Ocean as same as Progo River. The catchment basin of Opak River covers about 1,250 km² and the main river channel is 70 km in total length. The tributaries of Opak River on the slopes of Mount Merapi are Boyong, Kuning and Gendol Rivers. The biggest

tributary of Opak River is Oyo River with a catchment basin of about 700 km². This tributary joins Opak River at the 10 km upstream from the river mouth.

(3) Dengkeng river system

Woro River that carries a heavy sediment load is a tributary of Dengkeng River, which is located on the southeastern slope of Mount Merapi. Dengkeng River is relatively flat; therefore, its capacity of sediment discharge is relatively low. Consequently, the aggradation problem appeared in the downstream of Woro River.

2.4.2 Environment conditions in upper area

Mount Merapi has been known as one of the most active volcano in Indonesia as well as in the world. Its name means Mountain of Fire. The volcano is located on the border between Central Java and Yogyakarta. The climate in this region is wet tropical and rainfall intensity ranges from 875 mm/year to 2527 mm/year. The wet season starts in November and ends in May, while the dry season starts in June and ends in October. The land cover in Mount Merapi consists of tropical forest (11%), plantation (12%), dry land (29%), wet land (21%), settlement (9%), open land (12%) and lava deposits (6%). The forest ecosystem is located at an elevation of 600 to 2968 meter above sea level, and it covers 8,655 ha.

2.4.3 Environment conditions in downstream area

(1) Progo River

In the lower reach of Progo River, the riverbed is very unstable and the riverbed level changes from year to year, depending on the supply of sediment from Mount Merapi. Table 2.7 shows the average riverbed levels at the existing structures in the lower reach of Progo River. It indicates that the riverbed level tends to increase before 1970, but it decreases after 1970. Since 1970, riverbed degradation is observed at 10-30 cm/year (DGWR, 2001a). With the changes of riverbed slope and the sediment supply, the characteristic of the river in this reach changes. Hence, to predict the future characteristic of the river is difficult, because it will depend on the frequency of Mount Merapi eruptions.

Since Dutch Colonial Era, the lower reach of Progo River has been developed to contribute people's daily lives, especially for irrigation and domestic water supply. Beside, sand mining in the river stream has been carried out nowadays. The riverbed degradation in the lower reach of Progo River creates new sediment disasters, such as difficulties of irrigation operation and local scouring at the foot foundation of the river structures. The important structures affected by the riverbed degradation and water surface lowering are as follows. Figure 2.23 shows the location of these important structures in the lower Progo River.

Table 2.7 Riverbed fluctuation at the existing river structure

Existing structures	Average riverbed level (m)						
	1924	1929	1930	1970	1982	1984	2000
Srandakan bridge	-	11.2	-	-	-	-	6.00
Kamijoro intake	22.8	5	21.6	26.1	-	-	23.20
Bantar road bridge	-	-	8	3	-	40.93	36.30
Kebonagung bridge	-	-	-	-	57.60	-	52.00

(Source: modified from DGWR, 2001a)

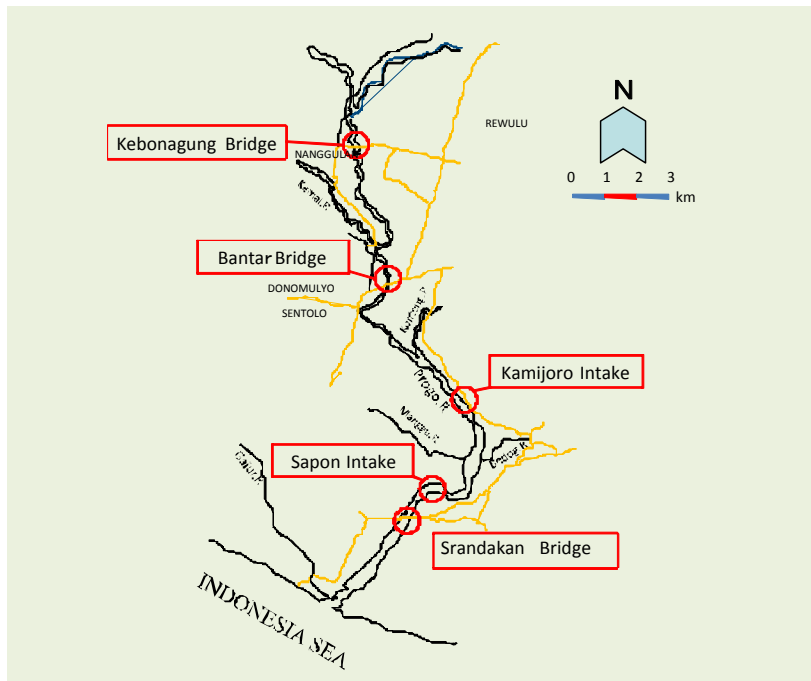

Fig. 2.23 Location of the important structures in the downstream of Progo River

a. Srandakan Bridge

The Srandakan Bridge is located at 6 km upstream of river mouth and has 531 m in length. It was constructed in 1878-1880 and rehabilitated in 1975-1985 due to the increase in traffic volume. The bridge function is to connect the Bantul and Kulon Progo Regencies. The average daily traffic volume is 6,500 vehicles (200 buses, 800 trucks, 400 cars, and 3700 motorcycles and 1400 bikes). In April 2000, two piers collapsed due to the local scouring around the foot of bridge piers. As countermeasures, the new bridge was constructed at the downstream from the old bridge and a groundsill was installed at approximately 340 m and 190 m downstream from the old and new bridges, respectively. The sand mining has been strictly prohibited within 2 km from the bridge in both upstream and downstream. Photo 2.2 shows the settled down piers and the constructed new bridge.

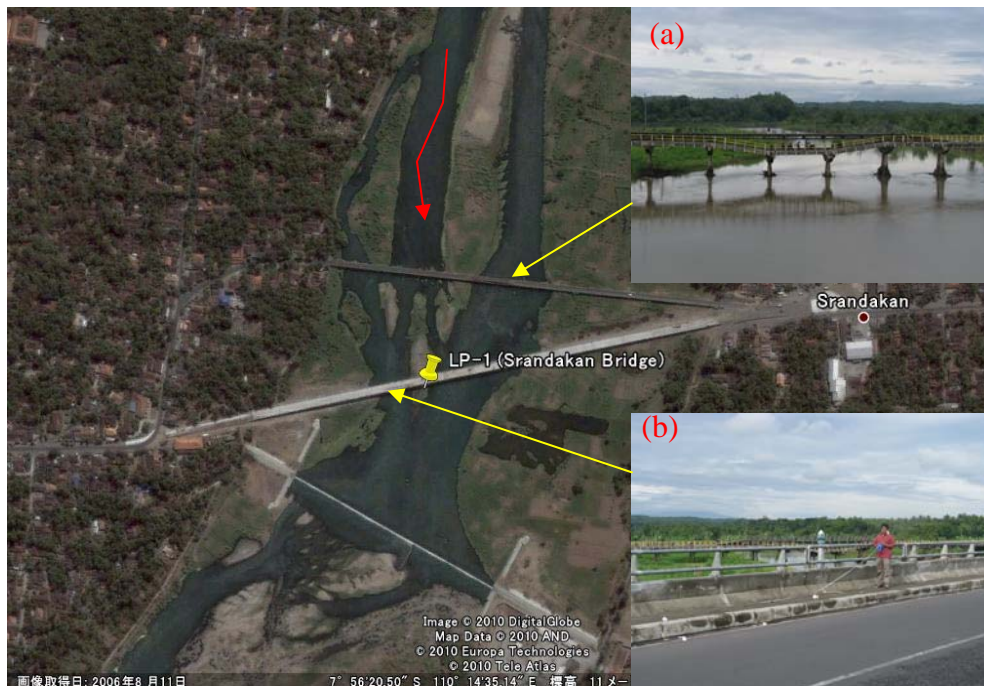

Photo 2.2 (a) The settled down piers and (b) the constructed new bridge. The both photos were taken in December 2008 (Source: Google Earth, 2010)

b. Bantar Bridge

Bantar Bridge is approximately located at 25 km upstream of the river mouth. It consists of road and oil pipeline bridges. Bantar Bridge is a part of the national transportation system. The traffic volume through the bridge is 9,100 vehicles per day. They consist of 800 buses, 2,000 trucks, 1,600 cars, 4,300 motorcycles, 400 bicycles. The old bridge was constructed in 1926-1930 with suspension type; the second one was constructed in 1987-1988 by Australian steel framework next to the old one. The new one was constructed between the first and second ones, to accommodate the increase in traffic volume. Moreover, an oil pipeline is also located at Bantar Bridge to convey oil from Cilacap to Yogyakarta with 8 million liter/day. At upstream from Bantar Bridge, there is the railway bridge connecting Surabaya and Jakarta. The daily traffic volume through the southern railway consist of 54 passengers and 8 cargo trains to carry almost 30,000 passengers. Photo 2.3 shows the bridges in Bantar and a foundation is exposed by the riverbed degradation.



Photo 2.3 (a) The Bridges in Bantar and (b) a foundation is exposed by the riverbed degradation. The photos were taken in December 2008
(Source: Google Earth, 2010)

c. Kebonagung Bridge

The Kebonagung Bridge is located approximately at 34 km upstream of river mouth with 153.6 m span and 7 m width. It was constructed in 1986 to connect Sleman and Kulon Progo Districts. Due to the severe riverbed degradation, a ground sill had constructed to protect the pier bridge. However, the ground sill had damaged during floods. Hence, the pier bridge is exposed by riverbed degradation as shown in Photo 2.4.

d. Sapon Irrigation Intake

Sapon irrigation intake shown in Photo 2.5 is located at 8km upstream from the mouth river. The first one was constructed in 1914 to irrigate paddy field of 1,917 ha in Kulon Progo District. Regrettable, it was destroyed by floods. The second one was constructed in 1982 to irrigate 2,230 ha. However, due to the severe bed degradation caused severe problem on function of the intake in 1995. The third one was constructed in 1998 at 500m upstream of the second one. However, it was not sufficient and stable. At present, a weir was constructed across Progo River at the downstream of the first irrigation intake.



Photo 2.4 The Kebon Agung Bridge. The foundation is exposed by the riverbed degradation. The photo was taken in December 2008
(Source: Google Earth, 2010)



Photo 2.5 The Saphon irrigation intake. The photo shows the water can not enter to the irrigation intake due to severe bed degradation
(Photo courtesy Masaharu Fujita)

e. Kamijoro Irrigation Intake

The Kamijoro irrigation intake is located at 14 km upstream of the river mouth and was constructed in 1924 to irrigate about 2,074 ha of paddy field in Bantul Regency. Currently, the intake can irrigate the area of about 2,300 ha and the maximum intake volume is about 2.3m³/s. The specific problem is that this intake always has a sedimentation problem in the irrigation channel and it does not often function during the dry season due to low water levels.

(2) Opak River

The Opak River is one of the main rivers in Yogyakarta Special Province and flows in the eastern side of Progo River. It flows from a slope of Mount Merapi in Cangkringan, Sleman district and empties into Indian Ocean in Sanden, Bantul district. It is one of perennial rivers. The length is about 65 km and its catchment area is 1398.18 km². It has several tributaries, for example: Gendol River, Opak River, Bening River, Woreng River, Tepus River, Kuning River, Gadjahwong River, Boyong/Code River, Winongo River, Pesing River and Oyo River. The relative big tributaries of Opak River in the upper reach at Mount Merapi are Gendol River, Kuning River, and Boyong River.

The riverbed degradation has taken place in the downstream of Opak River, although it is not as serious as in the downstream of Progo River. The condition can be seen since government constructed a groundsill at Kretek Bridge in 2003. Riverbed degradation increased due to sand mining activity since an earthquake disaster occurred on May 27, 2006, when the sand demand also increased rapidly. Consequently, the groundsill at Kretek Bridge collapsed for 40 m in June 2007, as shown in Photo 2.6. Beside, an irrigation intake after the groundsill had a difficulty in the operation. Therefore, the riverbed degradation in the downstream of Opak River needs to pay an attention, because 23 irrigation weirs, 1 free intake and 4 roadway bridges exist in the reach.



Photo 2.6 Impacts of riverbed degradation due to sand mining activity in the downstream of Opak River. Photos a, b, c were taken in June 2007 (Figure d source from Google Earth, 2010)

2.5 Summary

The questionnaire survey results show that sediment is an important resource to support inhabitants' daily life through sand mining activity. The activity has a positive socio-economic impact on Mount Merapi basin by providing job opportunities and giving additional income for inhabitants as well as local government. Inhabitants and local government give a good awareness to sabo works. Sabo dams have constructed for two purposes; first for sediment disaster mitigation and second for supporting regional development such as bridges and an irrigation water intakes. As a result, safety is secured and transportation access becomes more convenient.

Mount Merapi produces sediment disaster to local people at one side, but also it gives resources at another side. The mass movement such as pyroclastic and debris flows have damaged asset, infrastructure, and society. The disasters are triggered by natural activities such as volcanic activity of Mount Merapi and heavy rainfall or human activities. Local people and government use the resources by many ways to support the regional development. Local people use rivers as sediment source for making alternative income. Local government use sediment resources to get tax income. However, people tend to use the resources as much as possible, neglecting its sustainability, such as land clearing for agriculture, sand mining, and deforestation. Consequently, it produces another sediment disaster, such as riverbed degradation. Hence, it is necessary to develop a new concept of sediment management in Mount Merapi basin.

To achieve the purpose, sustainable sediment management will be developed and discussed in Chapter 3, through developing a concept of sustainable sand mining and sediment resource management combined channel works and sabo works. First, the previous sediment disaster and resources management will be investigated, then a concept of sediment management considering the both management will be developed. Off course, the effect of the sediment management on socio-economic and environment should be discussed. A method for evaluating the sediment management from three aspects of safety, utilization, and environment or socio-economic point of view will be presented in Chapter 4.

References

- Bantul Regency, (2005), *Atlas Bantul regency: final report*, 2005.
- Central Board of Statistics of Bantul Regency, (2008), *Bantul regency in figures* (in Indonesian).
- Central Board of Statistics of Sleman Regency, (2007), *Sleman regency in figures* (in Indonesian).
- Chester, D.K., Dibben, C.J.L., Duncan, A.M., (2002), *Volcanic hazard assessment in western Europe*, Journal of Volcanology and Geothermal Research, Vol. 115, pp. 411-435.
- Directorate General of Water Resources (DGWR), Republic of Indonesia (2001b): *Review master plan study on Mount Merapi, supporting report [C] regional development and sustainable sand mining*.
- Directorate General of Water Resources (DGWR), Republic of Indonesia, (2001c), *Review master plan study on Mount Merapi, supporting report [F] socio-economy*.
- Dove, M.R., (2008), *Perception of volcanic eruption as agent of change on Merapi volcano, Central Java*, Journal of Volcanology and Geothermal Research, doi:10.1016/j.jvolgeores.2007.12.037.
- Government of Yogyakarta Special Province, (2005), *Atlas special province of Yogyakarta*.
- Howes, D.D, and Minopoulos, D.M., (2004), *Perceptions of hazard and risk on Santorini*, Journal of Volcanology and Geothermal Research, Vol. 137, 2004, pp. 285-310.
- Heise, S., and Aplitz, S.,(2007): *The role of risk management and communication in sustainable sediment management*, Sustainable Management of Sediment Resources, Vol. 3, 2007, pp 1-8.
- Ikhsan, J., Fujita, M., and Takebayashi, H., (2009), *Sand mining impacts on socio-economic inhabitant and river bed variation in Merapi area*, JSECE Publication No.52, pp 50-51.
- Indra Karya, (1999), *Survey of sediment balance and management in Progo River : final report* (in Indonesian).
- Japan International Cooperation Agency (JICA), (2004), *Mount Merapi and Mt. Semeru volcanic disaster countermeasures Project (2)* http://www.jica.go.jp/english/operations/evaluation/oda_loan/post/2004/pdf/2-14_smry.pdf.
- Kamulyan, B., Darmanto, Legono, D., and Zurkurniyanti, B., (2010), *The community institution establishment and its role in sustainable environmental Management at Mount Merapi basin*, International Workshop on Multimodal Sediment Disasters Triggered by Rainfall and Earthquake and the Countermeasures, Yogyakarta, Indonesia, pp. 137-149.
- Lavigne, F., and Thouret, J.C., (2002): *Sediment transportation and deposition by rain triggered lahars at Merapi Volcano, Central Java, Indonesia*, Journal of Volcanology and Geothermal Research, Vol. 49, pp. 45-69.
- Legono, D., (2005), *Important Issues on sediment-related Disaster Management in Indonesia*, International Symposium on Fluvial and Coastal Disaster, Kyoto University, Japan, December 1-2.

- Public Work Agency of Indonesia, (2005), *Statistic online*, <http://pu.somee.com/> (in Indonesian).
- Santosa, L.W., and Sutikno, (2006), *Geomorphologic approach for regional zoning in the Merapi volcanic area*, Indonesian Journal of Geography, Vol. 38, pp. 53-68.
- Sarwono, (2002), *Community participation in conserving water resources in Progo river*, Colloquium of Water Resources Development, Bandung, Indonesia (in Indonesian).
- Sleman Regency, (2005), *Atlas Sleman regency: final report*.

Chapter 3

Sediment Disaster and Resource Management

3.1 Mount Merapi Activity

3.1.1 Introduction

It is well known that Mount Merapi is one of the most active volcanoes in the world. It is 2,968 m high and is located in the island of Java at 7°32'26.99"S 110°26'41.34"E on the border between Central Java and Yogyakarta Special Provinces. It has erupted 41 times in the last 200 years including 15 major eruptions. It generally erupts every 3 years with a major eruption every 9 years. The history of its eruptions is shown in Table 3.1 and Figure 3.1.

Its eruptions have produced large amounts of volcanic material as ash falls, lava, and pyroclastic flows. Volcanic activity occurred on the western slope during 1830–1870 and on the northwestern slope at the end of the 1800s. During 1903 and 1904, the volcanic activities moved to the eastern slope, then to the southeastern slope during 1905 and 1906, and then to the northwestern slope during 1909–1913. In the period from 1940–1994, volcanic activities were confined mainly to the southwestern slope, except for a short period on the northern slope during 1954–1956. During 1999–2001, volcanic activities moved from the southwestern slope to the western slope. The most recent eruption occurred in June 2006 on the southeastern slope. Mount Merapi has been producing a huge amount of sediment. Produced sediment is deposited on the slopes of Mount Merapi and is partly transported by water flow to the downstream areas through the tributaries that originate in the volcano. The location of deposited sediment is shown in Figure 3.2. The deposited sediment has caused many sediment disasters, and threatened local residents. On the other hand, in addition to threatening local people, the sediment is an important resource for them. Siswamidjoyo *et al.* (1995) have compiled the lava production data since 1890. The production rates of individual eruptive events have varied widely. However, the cumulative volume has increased nearly linearly.

Table 3.1 Historical eruptions of Mount Merapi

Year	Duration of activity (year)	Duration of non activity (year)	The peak time of eruption
1821			
1822*		1823-1831	
1832		1833-1836	
1837		1838-1845	
1846		1847	
1848			
1849*		1850-1861	
1862		1863-1864	
1865		1866-1868	
1869		1970	
1871-1872*	1	1872-1878	April 15, 1872
1878-1879	1	1879-1881	In 1879
1882-1885	3	1885-1886	January 1883
1886-1888*	3	1888-1890	
1890-1891	1	1891-1892	Augustus 1891
1892-1894	2	1894-1898	October 1894
1898-1899	1	1899-1900	In 1898
1900-1907*	7	1907-1908	Every year
1908-1913	5	1913-1914	In 1909
1914-1915	1	1915-1917	March-May 1915
1917-1918	1	1918-1920	
1920-1924*	4	1924-1930	February, April 1922
1930-1935*	5	1935-1939	Dec 18, 1930 and April 27, 1934
1939-1940	1	1940-1942	Dec 23, 1939 and Jan 24, 1940
1942-1943*	1	1943-1948	June 1942
1948-1949	1	1949-1953	September 29, 1948
1953-1954*	1	1954-1956	January 18, 1954
1956-1957	1	1957-1960	
1960-1962*	2	1962-1967	May 8, 1961
1967-1969*	2	1969-1972	January 8, 1969
1972-1974	2	1974-1975	Dec 13, 1972
1975-1985*	10	1985-1986	June 15, 1984
1986-1987	1	1987-1992	October 10, 1986
1992-1993	1	1993	February 1992
1993-1994*	1	1994-1996	November 22, 1994
1996-1997	1	1997-1998	January 14,17 1997
1998*	1 month	1998-2000	July 11, 19, 1998
2000-2001	1	2001-2006	February 10, 2001
2006			June 2006

Note: * indicates the major eruption

(Source: Directorate General Water Resources (DGWR), 2001b; Mananoma, 2008)

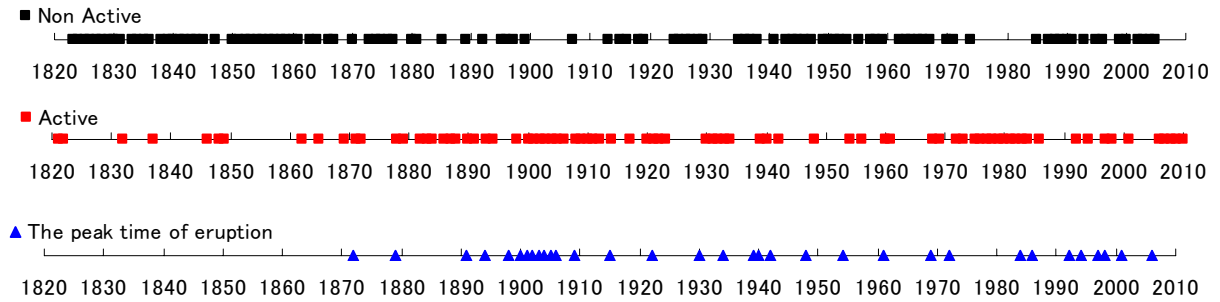

Fig. 3.1 The historical activities of Mount Merapi

This suggests that the lava production rate has been approximately constant, at $0.1 \times 10^6 \text{ m}^3$ per month (Voight *et al.*, 2000). According to DGWR report (2001e), the amount of magma produced by Mount Merapi from 1825 until 1945 was estimated at about $766 \times 10^6 \text{ m}^3$ ($0.51 \times 10^6 \text{ m}^3/\text{month}$). The rate of lava outflow from Mount Merapi widely varies, for instance, the rate from November to December 1930 is 300,000 m^3/day on average. In 1940 and 1942-1943, the rate of lava ranged 12,000-15,000 m^3/day on average and 30,000 m^3/day at the maximum. On the other hand, according to M.M Hadiwidjoyo and Suryo (1980), the amount of lava since 1900 to 1980 was estimated at about $279 \times 10^6 \text{ m}^3$ ($0.29 \times 10^6 \text{ m}^3/\text{month}$).

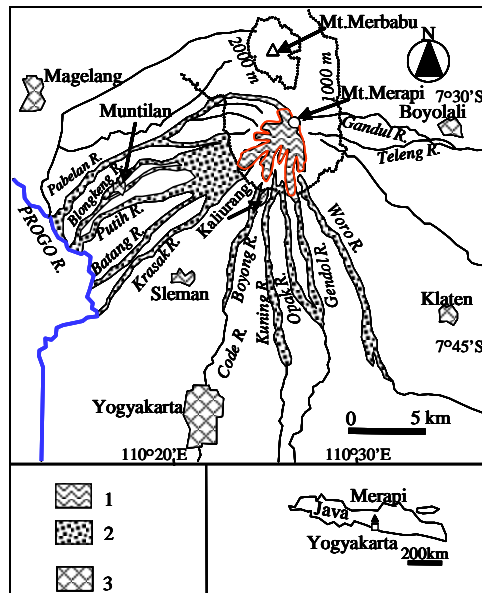

Fig. 3.2 Location of sediment deposits in Mount Merapi. (1: Summit lava dome and andesitic lava flow, 2: deposits from Mount Merapi, 3: main cities) (Modified from Lavigne and Thouret, 2002)

3.1.2 Sediment balance

Sediment production, sand mining, and sediment discharge to sea influence the current situation of sediment balance in Mount Merapi basin. Figure 3.3 shows cumulative lava productions (Siswowidjoyo *et al.*, (1995)). The production volumes of individual eruptive events are varied widely from less than 10^6m^3 to more than $20 \times 10^6\text{m}^3$, but the cumulative volume is proportionally increased and the annual average lava production rate is approximately estimated at around $1.2 \times 10^6\text{m}^3/\text{year}$. In Mount Merapi basin, sediment production from the non-volcanic basin cannot be neglected. The sediment production from non-volcanic basin is estimated at 20% of the sediment production from volcanic active basin (DGWR, 2001b), therefore, the annual average sediment production is equal to $0.24 \times 10^6\text{m}^3/\text{year}$. Thus, the annual average sediment production rate from Mount Merapi (volcanic active basin) and non-volcanic basin, Q_{spm} , is $1.44 \times 10^6\text{m}^3/\text{year}$.

The sand mining volume in the foothills of Mount Merapi in 2000 was estimated at $5-6 \times 10^6 \text{ m}^3/\text{year}$ (DGWR, 2001a). The sand mining persists not only in the foothills of Mount Merapi but also in the lower reach of river channel, especially in Progo River. In the Progo River, the sand mining activities are concentrated in the lower reach. The mining rate in the lower Progo River is estimated at about $2,933\text{m}^3/\text{day}$ ($1.07 \times 10^6\text{m}^3/\text{year}$) (Indra Karya, 1999).

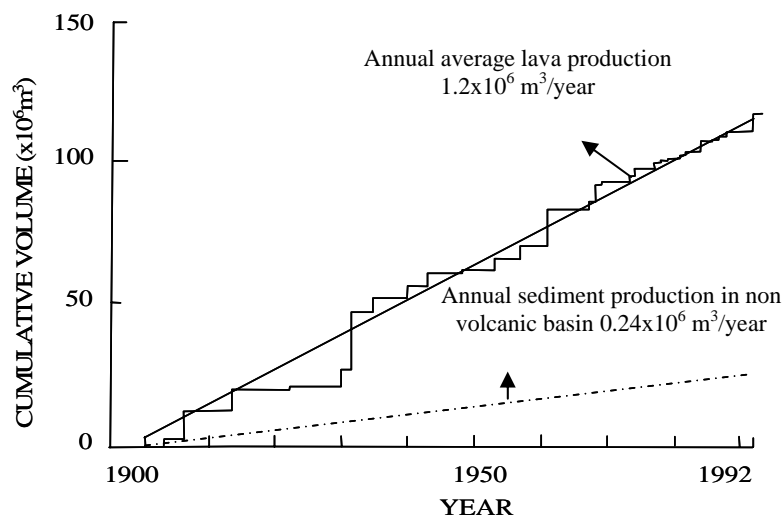

Fig. 3.3 Cumulative volume of lava production of Mount Merapi

According to DGWR report (2001a), the hydrological and topographical conditions in the lower Progo River are as follows; the annual average discharge is $83.1\text{m}^3/\text{s}$; the mean diameter of bed material is 1 mm, the average river width is 200 m, and the average bed slope is 0.0015. Under this condition, the total sediment discharge in the lower Progo River, Q_s , is estimated at $1.46 \times 10^6 \text{m}^3/\text{year}$ using Ashida and Michiue's bed load transport formula. This result shows the annual average sediment discharge is almost equal to the annual average sediment production rate. Therefore, the sediment discharge to sea balances with the sediment production rate. If the bed material is not removed by sand mining, degradation does not occur. However, actually total sand mining in the foothill area and the lower Progo River are $6.07 \sim 7.07 \times 10^6 \text{m}^3/\text{year}$. Thus, the riverbed degradation has occurred in the lower Progo River and caused instability of existing river structures such as sediment control dams, bridge foundations, and irrigation intakes.

In April 2000, one of the existing bridges, the Srandakan Bridge located in the lower Progo River collapsed. If no sediment is supplied to the lower Progo River because of active sand mining in the upper reach, the annual average degradation depth is estimated at 1.10 m/year. If sand mining activities in the upper reach does not turn down, it means no sediment supply into the lower reach continues for a long term. Under this condition, the bed slope will decrease from 0.0015 until the static equilibrium state of sediment transport is reached. The static equilibrium is estimated at 0.000156. Sediment production, sediment mining, and sediment discharge to sea influence the current situation of sediment balance in Mount Merapi basin as shown in Figure. 3.4

3.2 Current Situation of Sediment Disaster and Resource Management

3.2.1 Sediment disaster

Pyroclastic flows and debris flows happened very often on the slopes of Mount Merapi. In this sub-section, the occurrences of pyroclastic flows and debris flows in the slopes of Mount Merapi are introduced.

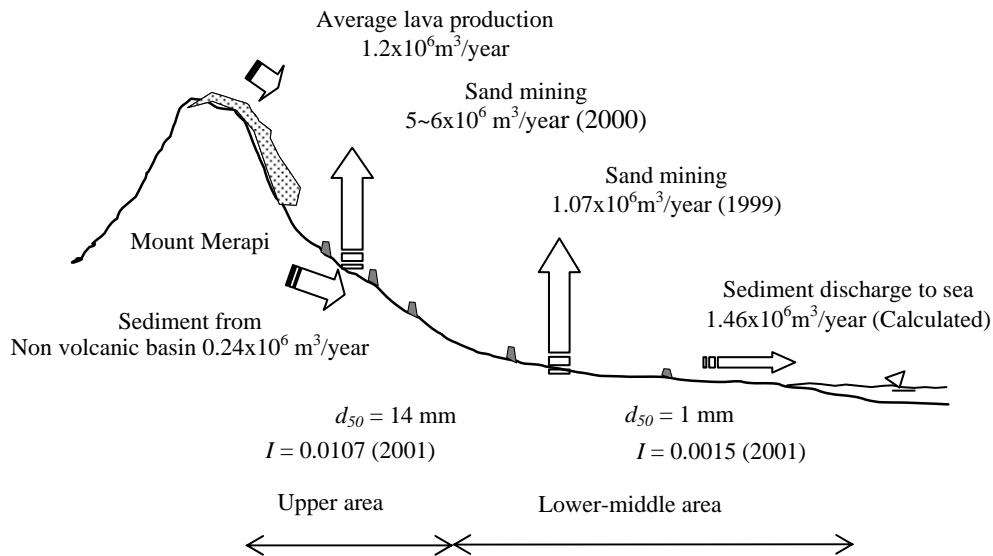

Fig. 3.4 Sediment balance in Mount Merapi basin

(1) Pyroclastic flows

Pyroclastic flows due to collapse of lava dome or lava tip have resulted in disasters in the downstream area and a tremendous amount of volcanic loose deposits on the slopes where the pyroclastic flows run down. During the last 100 years, the pyroclastic flows have run down on every slope of Mount Merapi (Voight *et al.*, 2000 and DGWR, 2001b). The pyroclastic flows have caused tremendous damages around Mount Merapi. A typical phenomenon of pyroclastic flow of Mount Merapi is accompanied by glowing cloud. The pyroclastic flows of Mount Merapi are classified into the two types based on its causes, namely lava dome collapse and explosion. Velocity of a pyroclastic flow was recorded at 110 km/hour at the maximum in the 1969 eruption. The other historical records were 108 km/hour in 1973 and 90 km/hour in 1984 (DGWR, 2001e).

(a) Avalanche-type pyroclastic flow

During an active stage of Mount Merapi, viscous lava flows over the crater forms, lava domes or lava tongues. The avalanche-type pyroclastic flow is originated from lava dome collapse, and is accompanied by glowing cloud in case of large-scale phenomena. According to R.W. Van Bemmelen (1949), small avalanches under 100 m^3 do not cause a pyroclastic flow, but that with more than $1,000 \text{ m}^3$ may cause a pyroclastic flow that expands rapidly (DGWR, 2001e). The reach of the avalanche

type is about 3 to 4 km from its origin and 7 km at the maximum. Photo 3.1 shows a pyroclastic flow accompanied by glowing cloud.

(b) Explosion-type pyroclastic flow

During a volcanic explosion, lava mass may be emitted from the eruption vent. The lava is thrown upward, and a part of it flows over the crater and rushes down a slope. This incandescent debris is an explosion-type pyroclastic flow, which is accompanied by glowing cloud. The affected reach of explosion-type pyroclastic flow is usually about 2 km. However, it depends on the scale of eruption. The maximum record in the 20-century is 13 km in the 1969 eruption. Figure 3.5 shows a diagram of the dominant directions of pyroclastic flows from 1901 to 2006.

The direction of pyroclastic flows stays almost on the southwestern slope during 37 years from 1961-1997. In this direction, the Bebeng and Putih Rivers exist. The direction of pyroclastic flow changed to the western slope during 1998-2001, expanding into the basin of the Putih and Senowo Rivers. However, in the last eruption 2006, the pyroclastic flow took place on the southeastern slope, which is within the Gendol and Woro River basins (Mananoma *et al.*, 2006). The sediment amounts produced by pyroclastic flows are presented in Table 3.2. The damages and casualties caused by pyroclastic flows have been listed up as shown in Table 3.3.



Photo 3.1 A pyroclastic flow accompanied by glowing cloud after the 1984 eruption
(Photo courtesy Adhy Kurniawan)

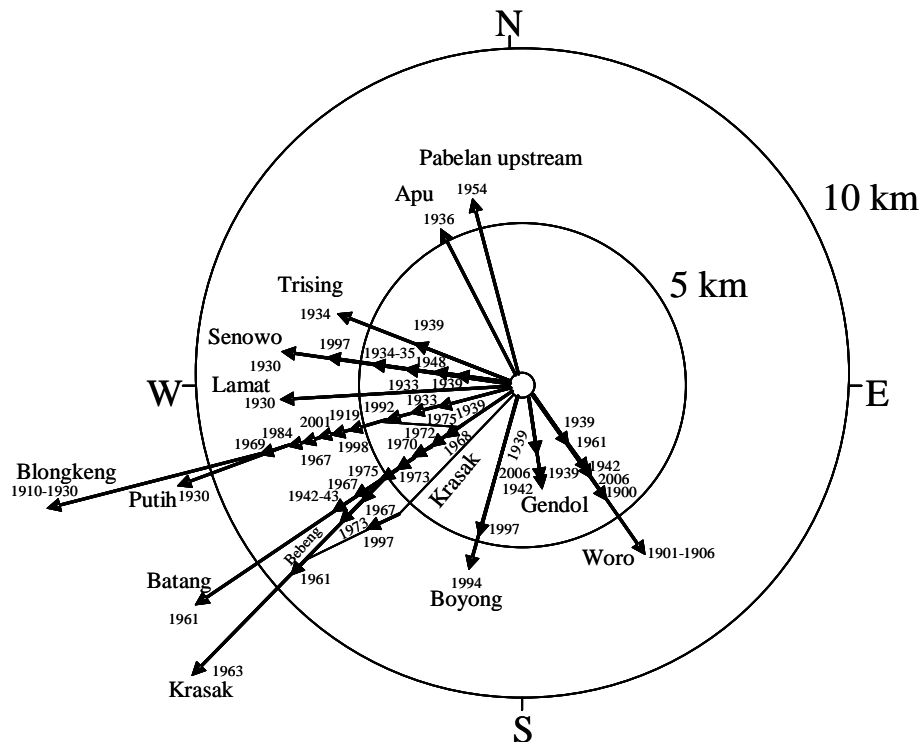

Fig. 3.5 Diagram of dominant directions of pyroclastic flows (Modified from DGWR, 2001b)

Table 3.2 Sediment amounts produced by pyroclastic flows

Eruption Year	Date of PF	Direction	Reach from summit (km)	Total sediment (Mm ³)
1930-31	Dec 18-19, 1930	W	15	NA
1942	Apr 12-May	SW	NA	2
1953-55	Jan 18, 1954	NW-SW	7	11.5
1961	Mar 19-Apr 11	W-NW-SW	6	20.2
	Apr. 18	SW	6.5	
	May 7	W-NW-SE	7	
	May 8	SW	12	
1967-68	Oct. 8, 1967	SW	7	3.2
1969	Jan 07	SW	7	5.6
	Jan 08	SW	8	
	Jan 08	SW	13	
1972-73	Apr.-Dec, 1973	SW	NA	3.9
1975	Jul 9-10	SW	5.5	1.0
1976-77	Mar 06-13, 1976	SW	NA	0.4
1979	Jun-Aug	NA	6	4.5
	Jun 13	NA	NA	
1984	Jun 15	SW	7	4.5
	Jan 20	NW	N/A	
1992	Feb 2	SW	4.5	2.0
	Mar 9 – Apr 8	SW	1.7	
1994	Nov. 22	S-SW-SW	6	2.6
	Jan 17	SW	6	2.0
1998	Jul 11, 19	W	6-7	8.8
	Nov 5,6	W	1-2	NA
2001	Jan 14	W	4	NA
	Feb 11	W	6-6.5	NA
2006	Jun 14	SE	4	NA

(Source: Voight *et al.*, 2000, DGWR 2001b and modified by author)

Table 3.3 Damages and casualties caused by pyroclastic flows

Year	Duration of activity (year)	Total sediment volume (Mm ³)	Casualties and damages properties
1006	NA	NA	Heavy casualties and the old kingdom were lost
1672	NA	NA	3,000 casualties
1822-1823	0.1	NA	50 casualties, 8 villages were destroyed
1832-1835	3		32 casualties
1902-1904			60 casualties, 20 injured
1920-1921	0.6		35 were killed
1930-1931	0.7	26	Area of 20 km ² was burned, 13 villages were completely destroyed, 1369 were claimed and 2000 animals died
1954		11.5	64 casualties, 3 villages destroyed
1961	0.75	42	6 killed, 6 injured
1969	0.4	10.8	3 casualties
1994	0.9	5.2	Turgo village was burned and 66 were killed
1996			6 missing
2006	0.25		Kaliadem village was burned, 2 casualties

(Source: Voight *et al.*, 2000, DGWR 2001b)

(2) Debris flows

During or just after an eruption, a huge amount of volcanic material is deposited on the slope of the volcano. Loose sediment and high intensity of rainfall cause a debris flow disaster. A debris flow is water-saturated debris flowing down on slopes under the gravity force. Debris flows commonly occur after or during heavy rainfall. Debris flows consist of material from clay to rock with a size of several meters. In Mount Merapi basin, debris flows start on the upper slope at the elevations of 1,000 to 2,000 m. Debris flows have frequently happened just after eruptions because pyroclastic flows piled up a huge quantity of loose sediments and ashes in the river basin of the volcano. The total number of the recorded debris flows from 1931 to 1996 is more than 500 times (DGWR, 2001b). 212 times of debris flow were happened in almost all the rivers, especially in Batang River, during 17 months after the eruption in November 1930. 247 times of debris flow happened in many rivers during 10 years after the eruption of 1969. 103 times of debris flow

happened during 12 years after the eruption of 1984 mainly in Putih, Bebeng and Boyong Rivers. The number of debris flows that happened in all rivers on the slopes of Mount Merapi is shown in Figure 3.6. The damages and casualties caused by debris flows have been listed up as shown in Table 3.4. Photo 3.2 shows the examples of damages by debris flows. The reasons why the volcano offers favorable condition for debris flow are the following three main factors.

(a) Pyroclastic deposits are abundant.

The amount of sediment produced by pyroclastic flow in one eruption varies from 0.4 to 20.2 million m³ (DGWR, 2001b). Based on the 61 reported eruptions since the mid-15 Century, at least 20 eruptions have provided sediment deposit over the area of 286 km² on the slopes of Mount Merapi (Lavigne *et al.*, 2000).

(b) Merapi area has high intensity rainfalls.

High intensity rainfalls commonly triggers debris flows in Mount Merapi basin. Average annual rainfall of the area is estimated at 2,460 mm/year and 82% of rainfall event are recorded in rainy season (from November to April) (DGWR, 2001d). According to Lavigne and Thouret (2002), rainfall intensity with 40 mm in 2 hours can commonly trigger debris flows. For example, between December 1994 and May 1996, 31 rain-triggered debris flow/lahar events were recorded in the Boyong River.

(c) Drainage is very dense.

There are 13 rivers from Trising River on the west flank to Woro River on the south flank. The rivers transport the produced sediment from Mount Merapi into the main river. The sediment has not only caused problems in the upstream area, but it also caused some problems in the downstream area. Damages by debris flows have occurred all the way from the upper slopes to the middle slopes where the hamlet and agricultural area are expanding on.

The history events of debris flows and damages caused by debris flows have been reported in previous papers (Lavigne *et al.*, 2000 and DGWR, 2001b). Table 3.4 presents the summary of debris flow events and damages of property.

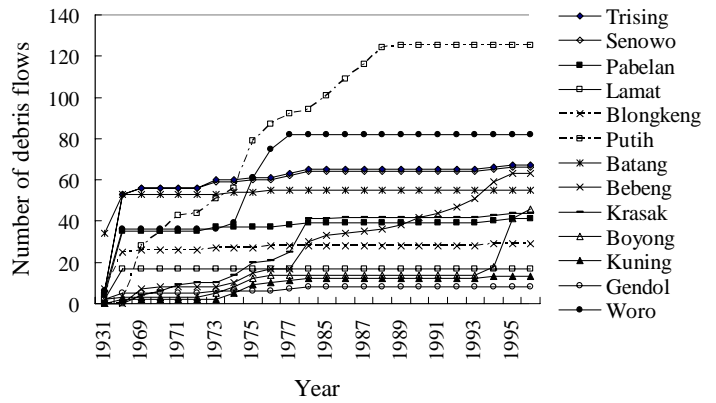
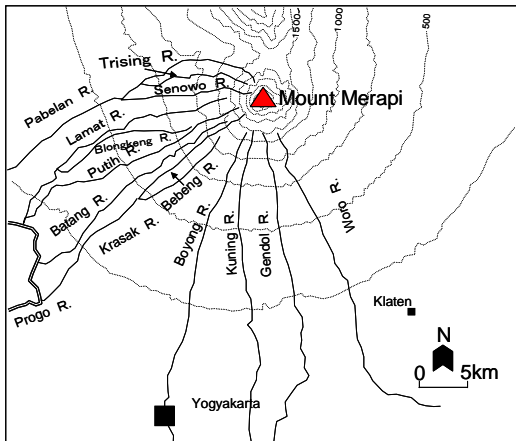

Fig. 3.6 The number of debris flows in every river on the slopes of Mount Merapi (Source: DGWR, 2001b)



Photo 3.2 (a) Damages at a village on Krasak River after a debris flow in 1969, (b) Damages on houses in a village near Krasak River after a debris flow in 1976, and (c) A bridge condition on Putih River after a debris flow in 1984 (Photo courtesy Adhy Kurniawan)

Table 3.4 Lahar related disaster at Mount Merapi

Lahar occurrence	Valley	Damages of property
28 December 1822	Se, Pa, Bl, La, Wo	4 Villages
25 December 1832	Bl	
November 1846	Wo	50 ha TL
5 October 1888	Tr, Se	1 Village
12 October 1920	Se, Bl, Ba	1 Village
19-20 December 1930	Se, Pa	1 Bridge, 70 ha ricefield
	Bl	1 Bridge, TL
	La, Pu	Irrigation system
	Bo, Ku, Wo	Water supply system of Kaliurang and Yogyakarta
	Ge	227 ha Coffee plant
2 January 1931	West and SW	TL, 1 bridge
11 January 1931	West and SW	TL
14 January 1931	West and SW	TL
27 April 1931	Ba	1 Bridge
17 February 1932	Se, Pa, La, Bl, Ba	TL
7 April 1932	Ba	1 Village, 2 bridges
27-28 November 1961	Se, Bl, Ba	5 Villages, 95 houses, 1 bridge
7-8 January 1969	Se, Pa	2 Villages, 38 houses, 25 ha TL
	Bl, Pu	4 Villages, 15 houses, 25 ha TL, 3 bridges
	Be, Kr	6 Villages, 239 houses, 103 ha TL, 2 bridges
	Bo, Co	2 Villages, 51 ha TL, 1 bridge
	Ku	2 Villages, 1 bridge
	Ge	9 Villages, 390 houses, >270 ha TL, 2 bridges
	Wo	6 Villages, 1 bridge
19 January 1969	Be	12 Houses
20 January 1969	Pu, oth	Tens of houses, 2 bridges
22 January 1969	Pu	15 Houses, 1 bridge
23 January 1969	Bl	3 Houses
26 February 1969	Se, Pu, Be, Kr	Tens of houses
5 April 1969	Pu	39 Houses
21 November 1969	Be, Kr	Houses, 1 road
22 September 1973	Be	3 Houses
26 January 1974	Be	9 Houses
22 October 1974	S	6 Houses
21 November 1974	Pu, Be, Kr, Bo, Ku	Several houses
22 November 1974	Pu, Be, Kr, Bo, Ku	43 Houses, several shops, 25 ha TL
6 December 1974	Kr	14 Houses
5 March 1975	Kr	102 Houses
22 March 1975	Kr	12 Houses
4 October 1975	Pu, Be, Kr	5 Villages, 20 houses, 30 ha TL, 1 bridge
25 November 1976	Pu	3 Villages, 2.3 ha TL, 1 bridge
	Be	17 Houses, 17 ha TL
	Kr	306 Houses, 4 buildings, 330 ha TL, 3 bridges
11 December 1994	Be	2 Trucks
2 February 1995	Be	3 Trucks
20 May 1995	Be	8 Trucks
3 March 1995	Bo	1 Bridge
5 December 1996	Bo	14 trucks
22 December 2006	Ku	Water supply system of Kaliurang and Yogyakarta
23 February 2007	Ge	2 Trucks
6 March 2007	Ge	1 Bridge
19 April 2007	Wo	2 Trucks
1 February 2008	Ge	1 Truck
15 March 2008	Ge	1 Truck

Note: Ba = Batang; Be = Bebeng; Bl = Blongkeng; Bo = Boyong; Co = Code; Ge = Gendol; Se = Senowo; Kr = Krasak; Ku = Kuning; La = Lamat; oth = others; Pa = Pabelan; Pu = Putih; TL = Tiled land; Tr = Trising; Wo = Woro.
(Source: Lavigne *et al.*, 2000 and DGWR, 2001b)

3.2.3 Sediment disaster countermeasures

(1) Necessity for countermeasures

Based on the volcanic hazard map built by Volcanological Technology Research Center (VTRC), the hazard area shown in Figure 3.7 consists of four districts, i.e. Magelang, Sleman, Boyolali and Klaten districts. The area is separated into three zones, namely a) forbidden zones, b) danger zones I and, c) danger zones II. The forbidden zone is within a radius of 10 km from the crater of Mount Merapi. It includes the area along the tributaries up to the maximum 15 km from the crater. The danger zone-I is an area around the summit, which is in a radius of 12 km and includes the area along the tributaries up to 15 km from the crater. The danger zone II is an area which is suffered by debris flows.

The numbers of villages, houses, and population in the hazard area are estimated at 112 villages, 46,833 houses, and 187,387 persons, respectively. Table 3.5 shows the data of population, houses, and villages in each zone (DGWR, 2001b). Population in forbidden area is estimated at 42,444, consisting of 17,903 (42%) in Magelang district, 15,306 (36%) in Sleman district, and 9,235 (22%) in Boyolali district. Population in the danger zone I are 29,448 (49.6%), 12,760 (21.5%), 9,811 (16.5%) and 7,322 (12.4%) in Boyolali, Sleman, Magelang and Klaten districts, respectively. 85,592 persons live in the danger zone II, consisting of 47% in Magelang district, 50% in Sleman district and 3% in Klaten district. Moreover, at least 1.1 million inhabitants live on its slopes and 440 persons live in high risk areas with prone to pyroclastic flows, pyroclastic surges and debris flows (lahar) (Thouret *et al.*, 2000). In the last eruption in 2006, the local government had about 44,500 persons who lived in the prone hazard zone evacuated (Marfai *et al.*, 2008).

(2) Method of countermeasures for sediment disasters

To overcome or prevent the sediment related disasters due to Mount Merapi activity, there are two kinds of disaster management used in Mount Merapi basin, namely structural measures and non-structural measures. For mitigation of the disasters due to the volcanic activities such as eruption, the non-structural method is used. Because it is very expensive to mitigate all disasters due to the volcanic activities by structural measures only. Hence, the combination method between two

managements, which are structural and non-structural measures, is used in order to mitigate the sediment disaster in Mount Merapi basin.

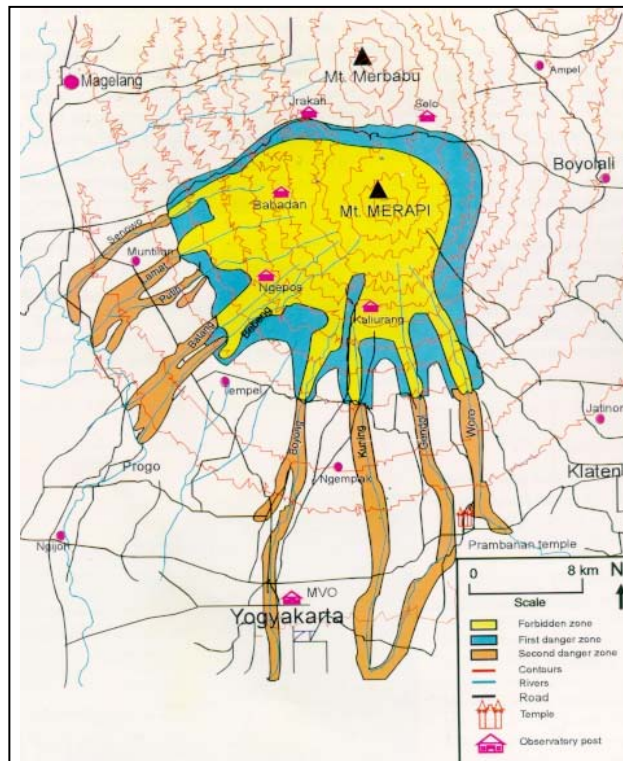

Fig 3.7 The hazard map of Mount Merapi
(Source: www.ipgp.fr)

Table 3.5 Number of population in the hazard zone

District	Hazard type	Number of village	Number of house	Population
Magelang	Forbidden Z	13	4,338	17,903
	Danger Z-I	10	2,324	9,811
	Danger Z-II	28	9,652	39,908
Sub total		51	16,314	67,622
Sleman	Forbidden Z	10	4,152	15,306
	Danger Z-I	9	3,862	12,760
	Danger Z-II	21	11,417	43,010
Sub total		40	19,431	71,076
Boyolali	Forbidden Z	4	2,298	9,235
	Danger Z-I	13	6,767	29,448
Sub total		13	9,065	38,683
Klaten	Danger Z-I	2	1,476	7,332
	Danger Z-II	2	547	2,674
Sub total		4	2,023	10,006
Total	Forbidden Z	27	10,788	42,444
	Danger Z-I	34	14,429	59,351
	Danger Z-II	51	21,616	85,592
Grand Total		112	46,833	187,387

(Source: DGWR, 2001b)

(a) Structural measures

Structural measures are conducted by sediment control facilities. Types of sediment control facilities, which are used in Mount Merapi basin are as follows:

- Check dam and consolidation dam: Functions of a check dam are to suppress sediment yield, to storage sediment and to regulate sediment discharge. A check dam can stabilize riverbed to protect from erosion and regulate the sediment discharge during floods. Most of check dams in Mount Merapi basin are built from concrete. If the dam height is more than 5.0 m, the dam is called as check dam and if the dam height is lower than 5.0 m, the dam is called as consolidation dam.
- Dispersion dam: The function of a dispersion dam is to direct the debris flow. Dispersion dams were constructed of masonry and concrete.
- Groundsill: The function of a groundsill is to protect riverbed from degradation.
- Riverbed girdle: The riverbed girdle is constructed to prevent the riverbed from degradation, but the crest of the structure is same level to the riverbed. All these structures have been built from concrete.
- Training dyke: A training dike is constructed in a lower riverbank to keep up the debris flow within the river course. Commonly, it is made from masonry and concrete.
- Revetment: It is constructed to prevent the riverbank from lateral erosion.

Sediment control facilities have been implemented in Mount Merapi basin based on the previous master plan established in 1980 and the review master plan in 2001 (DGWR, 2001a). The objectives of the previous master plan were to mitigate sediment discharge and sediment problems, which include the difficulty of irrigation water intake caused by sedimentation in rivers. Following this master plan, by 2001, 192 facilities with 50 check dams, 101 consolidation dams, 5 dispersion dams, 30 groundsills, 6 riverbed girdle, 53.275 km revetments and 12.033 km dykes were built as shown in Table 3.6 (DGWR, 2001b). Photo 3.3 shows the sabo works that have been constructed on major rivers in Mount Merapi.

Table 3.6 Existing of sabo works in Mount Merapi

River names	Check dam	Cons. dam	Disp. dam	Ground sill	Riverbed girdle	Training Dike (m)	Rev. (m)
Progo Tributaries							
a. Pabelan R	3	11					650
1) Trising R.	2	0					
2) Senowo R.	3	2				230	
b. Blongkeng R	3	10		1		2,130	230
1) Lamat R	4	3		5			1,700
2) Putih R	5	9				3,475	3,850
c. Batang R	4	1	5			2,548	150
d. Krasak R.	2	21					12,490
1) Bebeng R	7	4				3,650	4,520
Sub total I	33	61	5	6	0	12,033	23,590
Opak Tributaries							
a. Boyong R.	8	18		23	6		17,215
b. Kuning R.	4	1					
c. Gendol River	3	13					6,450
Sub total II	15	32	0	23	6	0	23,665
Dengkeng Tributaries							
a. Woro R.	2	8		1			5,960
Sub total III	2	8	0	1	0	0	5,960
Total	50	101	5	30	6	12,033	53,275

(Source: DGWR, 2001b)



Photo 3.3 Existing of sabo works on slopes of Mount Merapi. (a) A Check dam functioned as an intake and a sand pocket on Blongkeng River (BLD1). (b) A Consolidation dam on Putih River functioned as a bridge (PU-C8A)
(Photos were taken in December 2008)

(b) Non-structural measures

Definition of non-structural measures is as follows

- a) Forecasting and monitoring of pyroclastic and debris flows.
- b) Warning and evacuating inhabitants from disasters.
- c) Regulation of land use, including resettlement,
- d) Education on disaster prevention to inhabitants.

Non-structural measures are necessary for some reasons. First, non-structural measures are used as a measure until completion of structural measures, because structural measures take usually a long time for its implementation. Second, disasters that are greater than the plan sometimes take place. In Mount Merapi basin, non-structural measures were conducted by observation of the activities of Mount Merapi and prediction of pyroclastic/debris flows, with warning and evacuation system, and providing information on disaster reduction to inhabitants through books or training activities. Prediction, observation, warning, and evacuation systems are described briefly as follows.

a) Forecasting and warning

For monitoring, prediction, and warning of sediment related disasters in Mount Merapi basin, there are 2 institutions, which are the Volcanological Technology Research Centre (VTRC) and the Sabo Tehnical Centre (STC)/Research Centre for River and Sabo (RCRS). The VTRC has responsibility to monitor volcanic activity. The main tasks of the VTRC are to inspect the activities and to give suggestion for minimalizing the disaster effects caused by Mount Merapi eruption. The VTRC is under coordination of Ministry of Energy and Mineral Resources. In Mount Merapi basin, there are five observation stations positioned for supporting the VTRC's tasks.

The main tasks of the STC/RCRS are monitoring, forecasting and warning against debris flows/mud flows. The position of the STC/RCRS is the under coordination of Ministry of Settlement and Regional Development. In Mount Merapi basin, there are 6 rain gauge stations, 9 water level gauge stations in 6 rivers and 6 locations of debris flow equipment in 5 rivers.

b) Disaster prevention and evacuation

For disaster prevention activities in Mount Merapi basin, there are some institutions for coordination of disaster management, namely SATKORLAK-PB (provincial level), SATLAK-PB (district level), UNIT OPERASI-PB (sub-district level), and SATGAS-PB (village level). The system against sediment disaster in the area is shown in Figure 3.8. For normal warning against volcanic activity, the VTRC will give warning to the SATLAK-PB and then the SATLAK-PB informs to UNIT OPERASI-PB. Finally, the information will be continued to the SATGAS-PB. The SATGAS-PB informs directly inhabitants of it. However, in urgent situation, the VTRC directly informs to the SATGAS-PB, and the SATGAS-PB continues the information and gives warning to inhabitants to evacuate from dangerous area. Regarding debris flow disasters in the normal warning, the STC/R CRS gives warning to the SATLAK-PB and then the information will be continued to the SATGAS-PB. The SATGAS-PB informs inhabitants of the status. In urgent situation, the STC/R CRS directly informs the SATGAS-PB, and the SATGAS-PB gives warning to inhabitants to evacuate from the dangerous area.

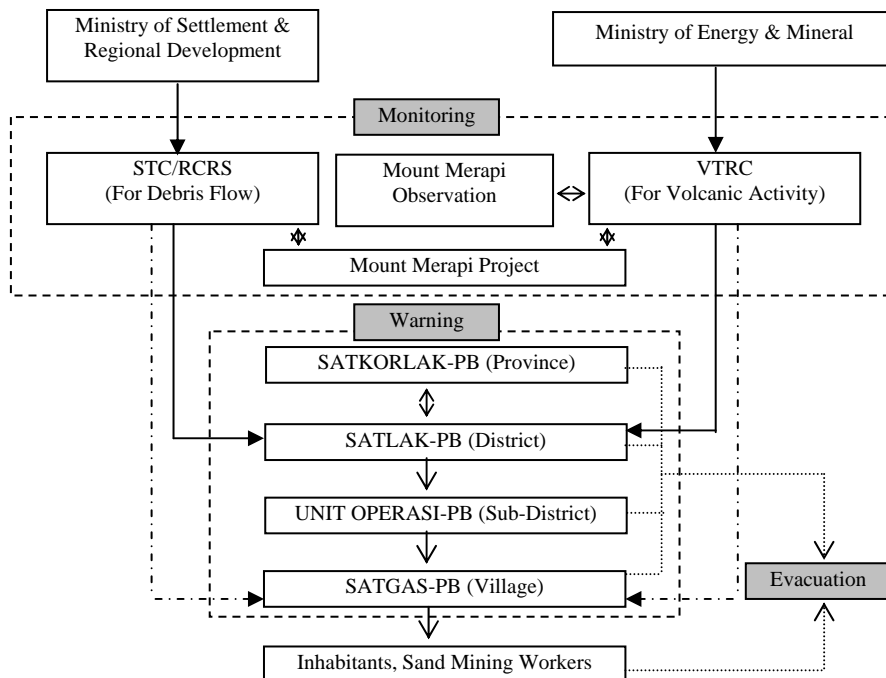

Fig. 3.8 Flowchart of the early warning of sediment related disaster in Mount Merapi (modified from DGWR, 2001b)

3.2.4 Sediment resource management

The volcanic materials were deposited on the slopes of Mount Merapi. The deposited sediment has a good quality for construction material; its specific gravity is between 2.65 to 2.70 with silt containing of 0.06% to 1.4 % (Sutikno *et al.*, 2003). Local people have the work of sand mining activities using traditional equipment. Due to increase in consumption of sand, sand mining has been extended rapidly and mining companies have used heavy industrial machines since 1994. Quarry sites in Mount Merapi basin are extended to not only riverbed but also private lands and riverbanks. The location of sand mining activities in foothills of Mount Merapi is shown in Figure 3.9. Photo 3.4 shows sand mining activities in one of the slopes of Mount Merapi. Distribution of sand mining volume by rivers in 2000 is shown in Figure 3.10. In Progo River, the sand mining activities concentrate in the lower reach as shown in Figure 3.11.

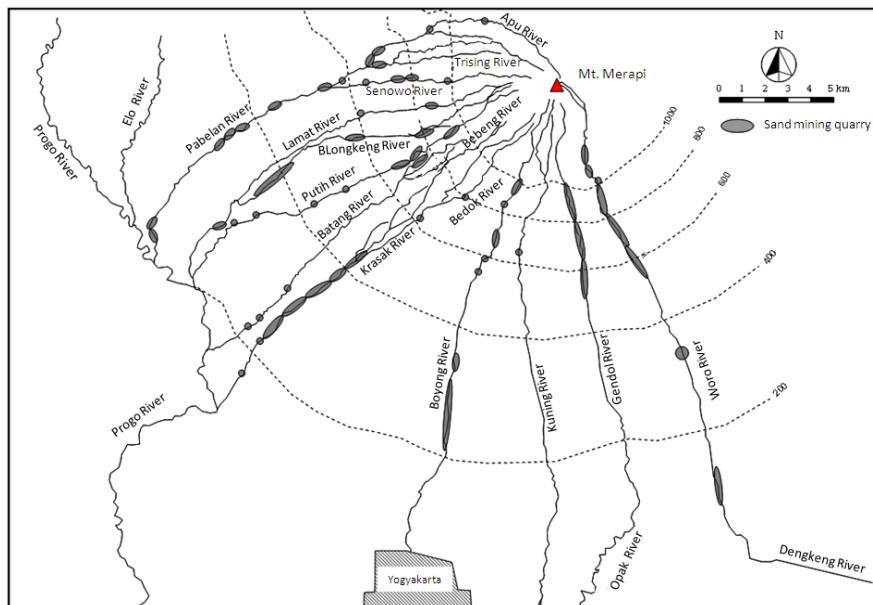

Fig. 3.9 Location of sand mining activities on the foothills of Mount Merapi (Source: DGWR, 2001a)



Photo 3.4 Sand mining activities on the foothills of Mount Merapi. Photo (a) shows the sand mining activity in Gendol River. Photo (b) shows the sand mining activity in nearby Woro River. (Photo (a) courtesy Haryono Utomo)

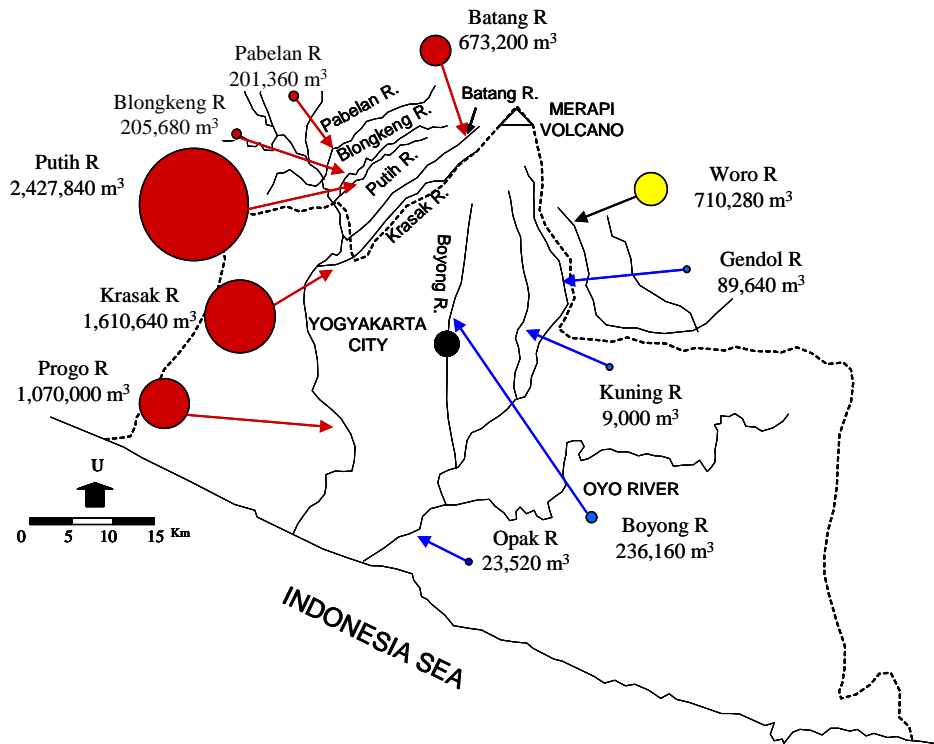

Fig. 3.10 Distribution of sand mining volume by rivers in 2000 (Source: DGWR, 2001c)

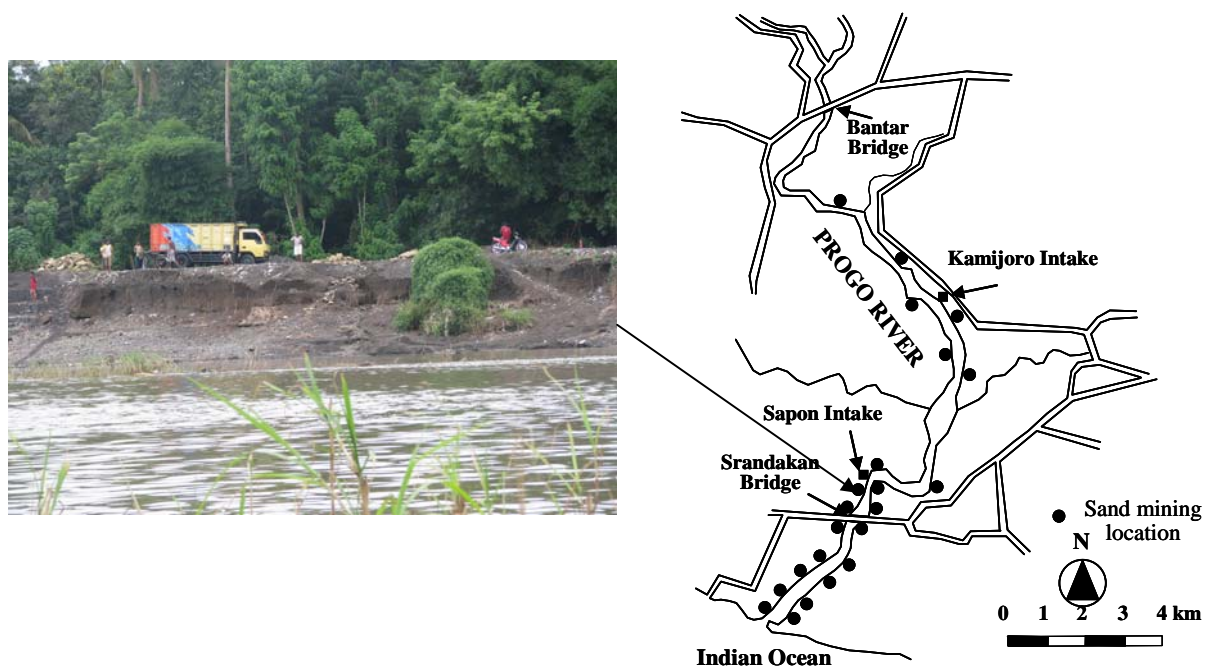

Fig. 3.11 Sand mining locations and its activity on the lower Progo River

The sand mining activities in the area have become very active because of the following reasons. First, the high price of the sand is so attractive. The transportation cost of sand from the mountain to Semarang city is 15,000 rupiah/m³, while its sale price is 100,000 rupiah/m³. Second, a sense of security provided by the sabo facilities has encouraged people to use the land and other resources as well as the deposited sand in this area. Sand mining activities can provide additional income during the off-season of agriculture. Third, poverty and unemployment have forced local people to get involved in sand mining activity as individual miners or laborers of a private sand mining company. The distribution of miners by the rivers in 2000 is shown in Figure 3.12. Fourth, a lack of education leads local people to prefer sand mining to other kinds of jobs, because the activity does not require specialized skills. Fifth, the activities give additional income to local government.

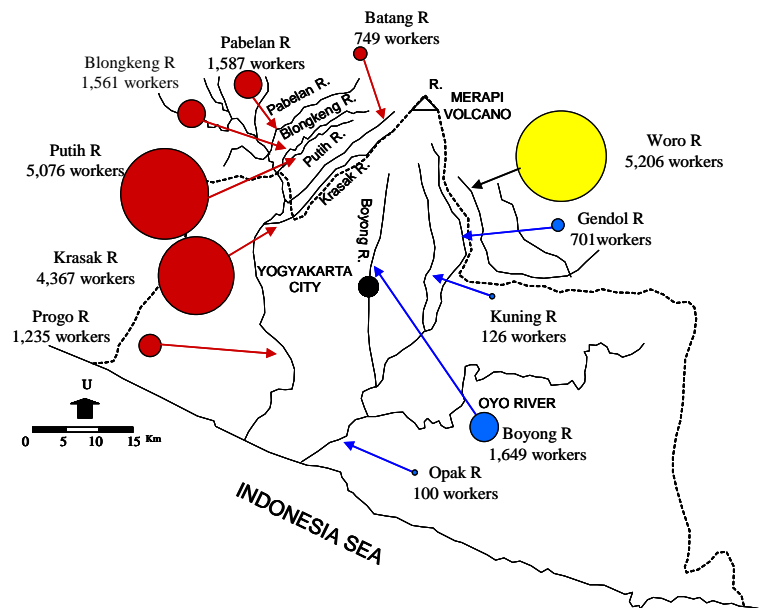

Fig. 3.12 Distribution of miners in Mount Merapi basin
(Source: DGWR, 2001c)

(1) Sand mining permit letter

Before starting a sand mining activity, individual person/group, association, firms/company must have license. There are two types of sand mining permits, namely Regional Mining Permit Letter (SIPD/Surat Ijin Penambangan Daerah) and Regional Mining Permit Letter-People Mining (SPID-PR/Surat Ijin Penambangan Daerah-Penambangan Rakyat). Diagram flow to make SIPD and SIPD-PR is shown in Figure 3.13.

Existing problems associated with sand mining permit in Mount Merapi basin, which are: a) long-time process for making a sand mining permit letter, b) lack of monitoring and guidance, c) expansion of non-registered miner and d) uncontrolled transportation system (DGWR, 2001c). A long time to make a sand mining permit letter leads an illegal sand mining. Consequently, it will reduce revenue to local government. The mining process is likely to cause negative environmental impact because of the lack of a monitoring and guidance of sand mining. Uncontrolled sand transport system would cause negative impacts such as road damage, noise, and dust.

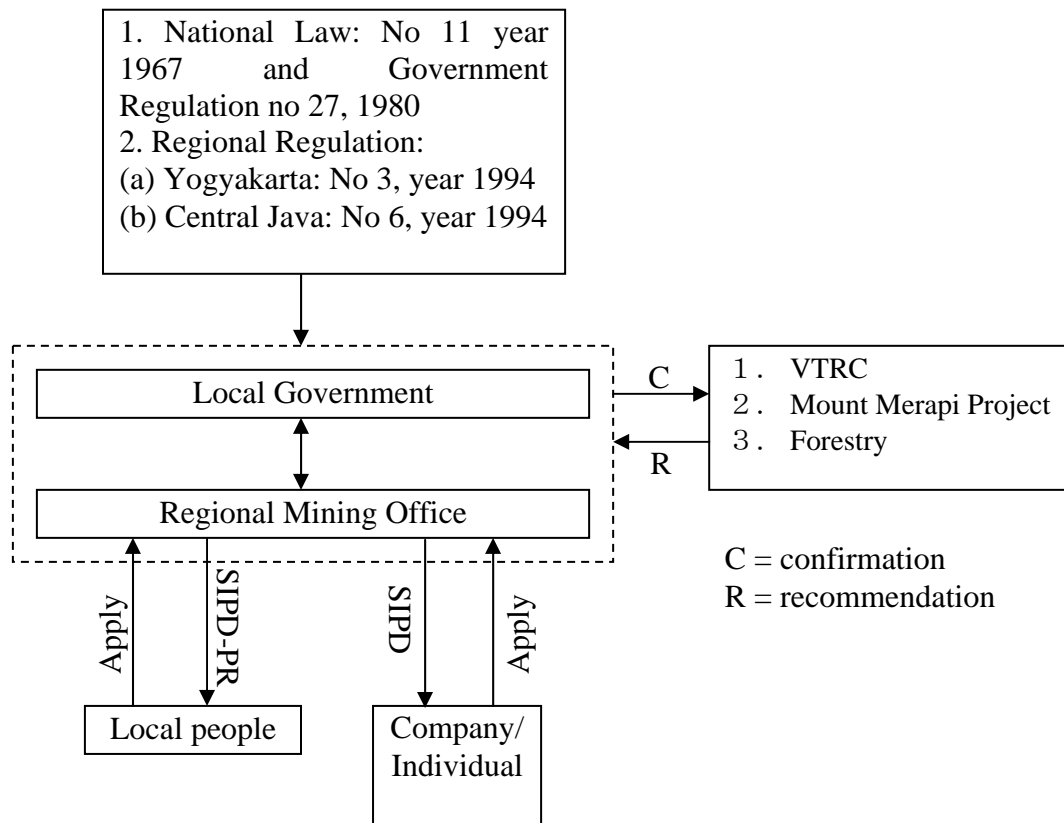

Fig 3.13 Flowchart of sand mining letter permits

(2) Sand mining tax

In 1999, Indonesia government started to apply new laws, namely the laws 22/1999 (Administration of Regional Government) and 25/1999 (Financial Balance between Central and Regional). The both laws provided regional governments (district governments) with much more financial autonomy. Before the regional autonomy policy was applied in 1999, the province governments handled taxation system and then each province allocates the collected tax to the district. After 1999, the district government can handle the taxation system. Consequently, the district governments established their own taxation system. The problems related to the difference system among district governments are various market prices, expansion of administrative service gap and social conflict. The sand mining tax of each district in Mount Merapi is presented in Figure 3.14. The figure indicates that the sand mining tax income has tremendously increased since 1999. For instance, the sand mining tax of Magelang district in 1998 was 264 million rupiah. However, in

1999, the sand mining tax was 868 million rupiah or about 3.29 times of 1998. The sand mining tax has increased significantly since 1999. Hence, the both laws have motivated local government to increase tax incomes as well as sand mining tax income.

Figure 3.14 also shows that the sand mining tax of Magelang district is bigger than other districts. The reason why Magelang district can collect the sand mining tax bigger are as follows:

- Historically, Mount Merapi activity almost took place in the southwestern slope, so that large amount of sediment deposited in a region of Magelang district.
- Using heavy equipment machine in sand mining process, consequently the sand mining activities produce large amount of sand volume,
- Magelang district has a higher price of sand mining tax compared with two other districts (Sleman and Klaten districts),
- Magelang district has good control gate systems, and
- There are many access routes to quarry sites for sand mining transportation located in Magelang district.

Moreover, Figure 3.14 also shows that the effect of Mount Merapi eruption on sand mining tax income. During an eruption, the sand mining activities in the slopes of Merapi will decline. As a result, the sand mining tax income also decreases. For example, the sand mining tax income of Magelang district is decrease in 2006 due to Mount Merapi eruption. After an eruption finish, the sand mining activities become normal again and tend to be more active, especially in the location where the eruption took place.

Figure 3.15 shows the ratio of sand mining tax to total tax. From Figure 3.15, it indicates that the sand mining is the most important for Magelang district compared to the other districts. For example in year 2007, the ratio of sand mining tax to total tax of Magelang was about 13.09%, but Sleman and Klaten were only 1.43% and 2.31%, respectively.

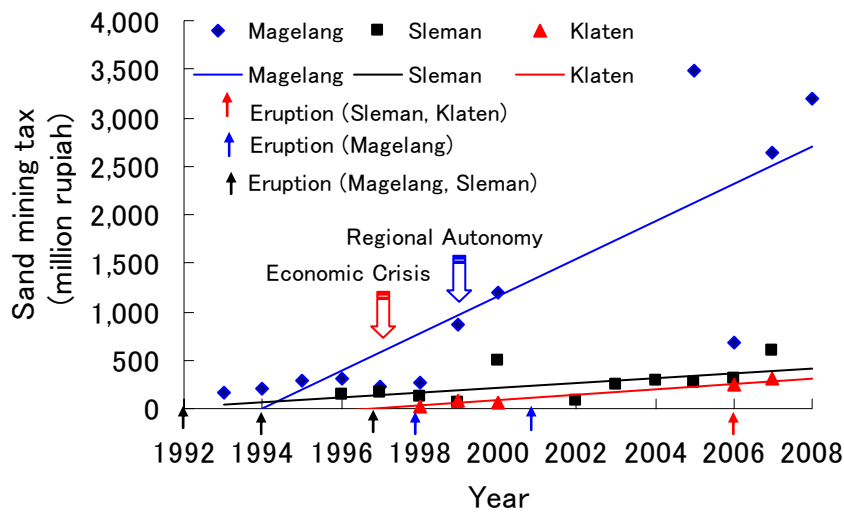

Fig. 3.14 The sand mining tax of each district in Mount Merapi basin

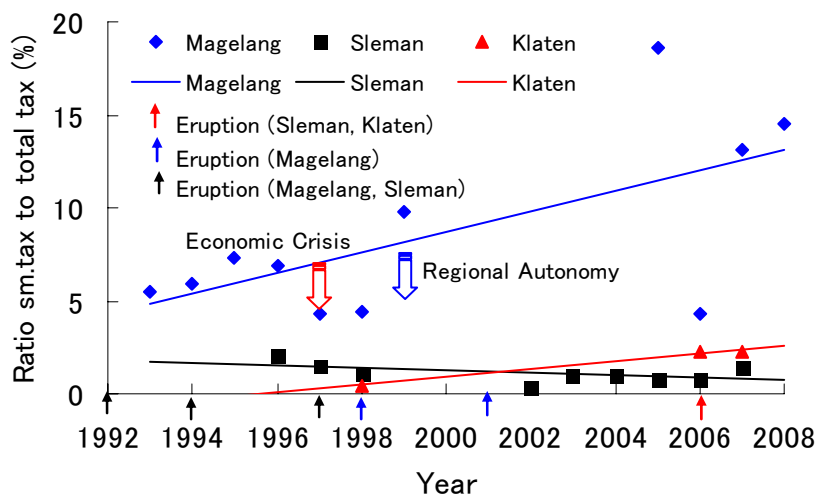

Fig. 3.15 The ratio of sand mining tax to total tax

(3) Sand mining volume

The volume of sand mining has increased significantly since 1999 when the regional autonomy policy started in Indonesia. Figure 3.16 shows the estimation of sand mining volume in the districts around Mount Merapi basin with unavailable data for some years. The data was estimated based on the sand mining tax collected by the local governments. The volume of sand mining in 1997 and 1998 was still

relatively low even though the economical crisis had begun in mid-1997, and it was estimated at 609,718 and 671,580 m³/year, respectively. The volume of sand mining has increased significantly since 1999. The sand mining volume in 1999 was estimated at 1,462,799 m³/year. The estimation of sand mining volume is smaller than the data from DGWR (2001c). According to DGWR (2001c), the sand mining volume in 1997 and 1998 was estimated at 3 million m³ and 5 million m³, respectively. In 1999, the volume of sand mining was estimated at 6 million m³.

The reasons why the sand mining volume has increased significantly after 1999 are due to the regional autonomy policy and the negative impacts of Indonesia's economical crisis in 1997. In accordance with the regional autonomy policy, the proportion of tax income allocation between the central and the regional governments is 20% and 80%, respectively (Amri, 2000), consequently district governments were motivated to increase tax incomes as well as sand mining tax income. For example, the ratio of sand mining tax to total tax for districts in the Mount Merapi basin was 0.46% to 9.81% in fiscal year 1999/00. Nevertheless, in fiscal year 2007/08, the ratio of sand mining tax to total tax increased to 1.43% to 13.09%. The other reason why the sand mining volume increases is the poverty as impact of the economical crisis that began in mid-1997. The average percentage of poverty people in Indonesia has increased very significantly from 16.6% in 1996 to 27.2% in 1999. In Yogyakarta Special Province, the poverty people increased from 16.2% in 1996 to 26.9% in 1999 (Suryadi and Sumarto, 2003). Poverty here means if their income is lower than the minimum standard income of government rule. People need an additional income to survive under this condition, and look for a new income source such as sand mining activity. Because of the two reasons, the current situation of sand mining activity in Mount Merapi basin is very active.

Beside due to the regional autonomy policy and the economical crisis in 1997, sand mining intensity is also influenced by Mount Merapi activity. For example, the pyroclastic and the debris flows during the 2006 eruption flowed on the southeastern slope, where Gendol and Woro Rivers are located. After the eruption of 2006, the sand mining activities in the both rivers were accelerated.

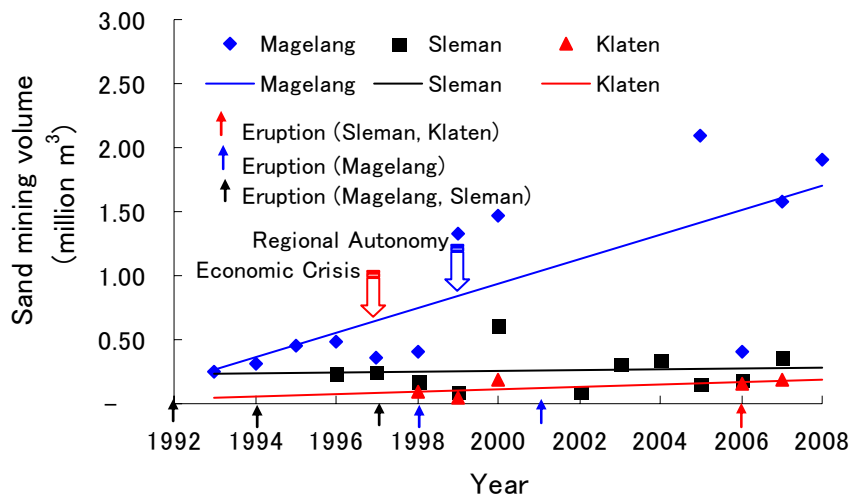

Fig. 3.16 Sand mining volumes estimation of each district around Mount Merapi

The effect of the Mount Merapi eruption on sand mining activities from 1960 up to present was investigated based on some reports (DGWR, 2001a). Figures 3.17 and 3.18 show the results on relation between pyroclastic flows and sand mining activities. Historically, sand mining has done by local people for a long time. Due to the eruption in 1961, pyroclastic flows have taken place in most tributaries, namely Senowo, Lamat, Blongkeng, Batang, Krasak and Gendol Rivers, and then sediment deposited in those tributaries. The deposited sediment had attracted local people to mine it, so that sand mining activities started to be active in those tributaries. During 1967-1969, the pyroclastic flows took place in the southwestern slope, and provided sediment resources in this area. The sand mining activities in this area became more active than before, especially in Blongkeng, Putih, Batang and Krasak Rivers. Senowo, Lamat and Woro rivers were not supplied sediment from Mount Merapi in this period, the sand mining still continued even though the intensity was not so active. The similar situation to period of 1967-1969 continued until 1992.

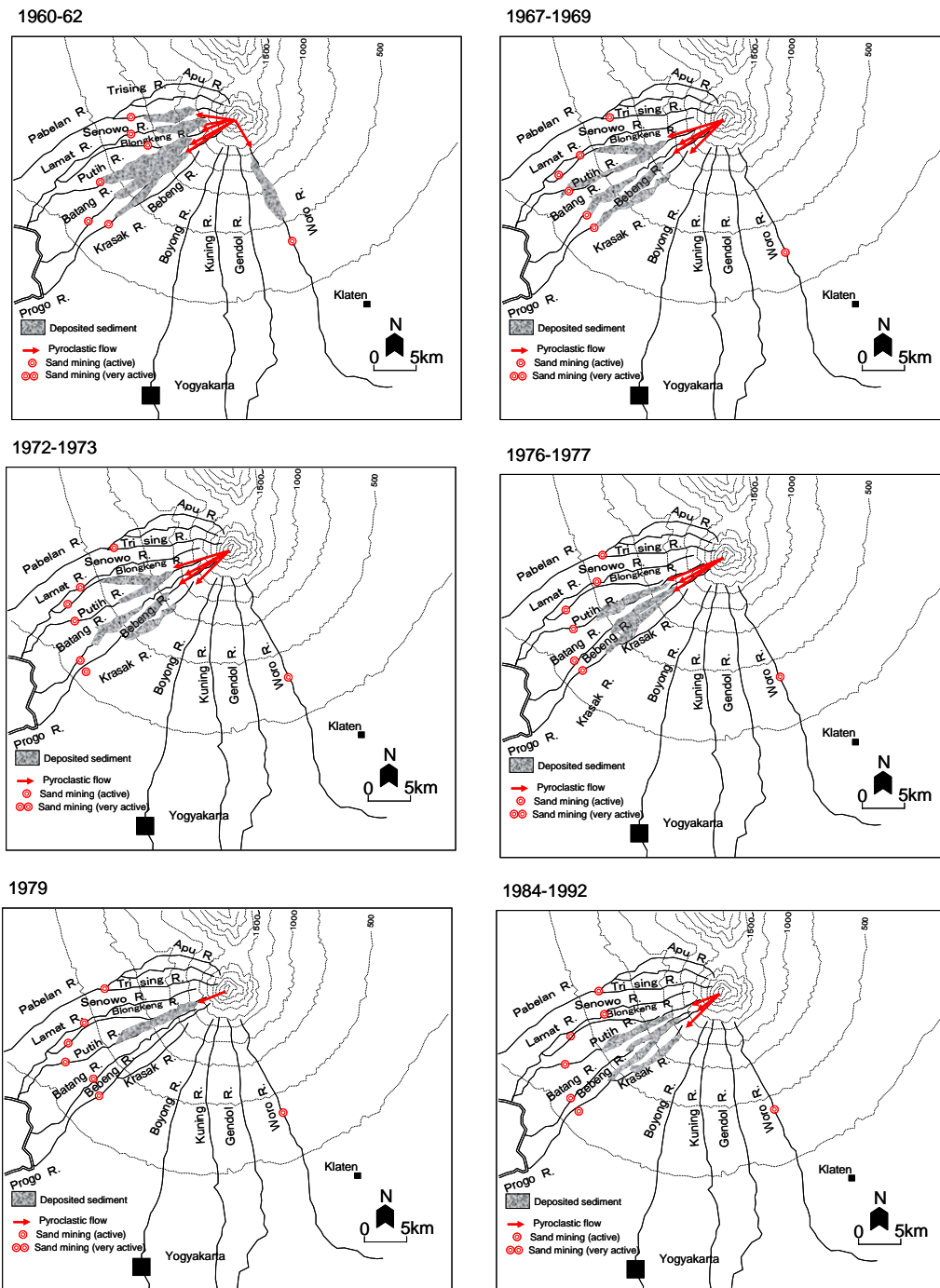

Fig. 3.17 Effects of Mount Merapi eruptions on sand mining activities from 1960 to

1992

In period of 1992-1994 as shown in Figure 3.18, sand mining activities conducted in all tributaries due to increase in sand demand. Since 1994, sand mining activities conducted using heavy equipment machine, especially in the southwestern slope. As a result, sand mining in this area became active more than before, especially in Putih and Krasak Rivers where the deposited sediment is abundant. In 1994 and 1997, pyroclastic flows occurred in Bebeng and Boyong Rivers and provided sediment in the both tributaries. As the additional sediment supply, sand mining activities in the both tributaries became very active. In 1998 and 2001, pyroclastic flows took place again in the western slope. This condition has accelerated the sand mining activities in this area. Consequently, the sand mining activities in Senowo, Lamat, Blongkeng and Putih Rivers became very active. In 2006, the pyroclastic flow direction changes from the western slope to the southeastern slope. Pyroclastic flow occurred in Kuning, Gendol and Woro Rivers and gave sediment in those tributaries. After the eruption in 2006, the sand mining activities in this area is more intense. Even though the pyroclastic flow direction has moved from the southwestern slope, the sand mining in this area still very active, particularly in Putih and Krasak Rivers.

The effects of pyroclastic flow, the economic crisis, and the regional autonomy policy on sand mining activity are shown in Figure 3.19. The figure shows conditions of sand mining activities in five rivers, i.e. Putih, Krasak, Boyong and Gendol, and Woro Rivers. After the economic crisis in mid-1997, many people lost their job and the poverty people increases. Therefore, they need a new job or additional job for making income, and non-formal sector occupations such as sand miner grow fast after the economic crisis. Consequently, sand mining in most rivers is more active. Beside that, the regional policy that applied since 1999 also accelerated the sand mining activities in Mount Merapi basin, because the district governments need additional tax incomes as the sand mining tax. As a result, the sand mining in the rivers is more intense after 1999. In addition to these two reasons, pyroclastic flows also give a contribution on sand mining activity. If a pyroclastic flow took place in a river, it means that the sediment resource increases in the river. This condition will accelerate sand mining intensity, so that the sand mining activity becomes very active.

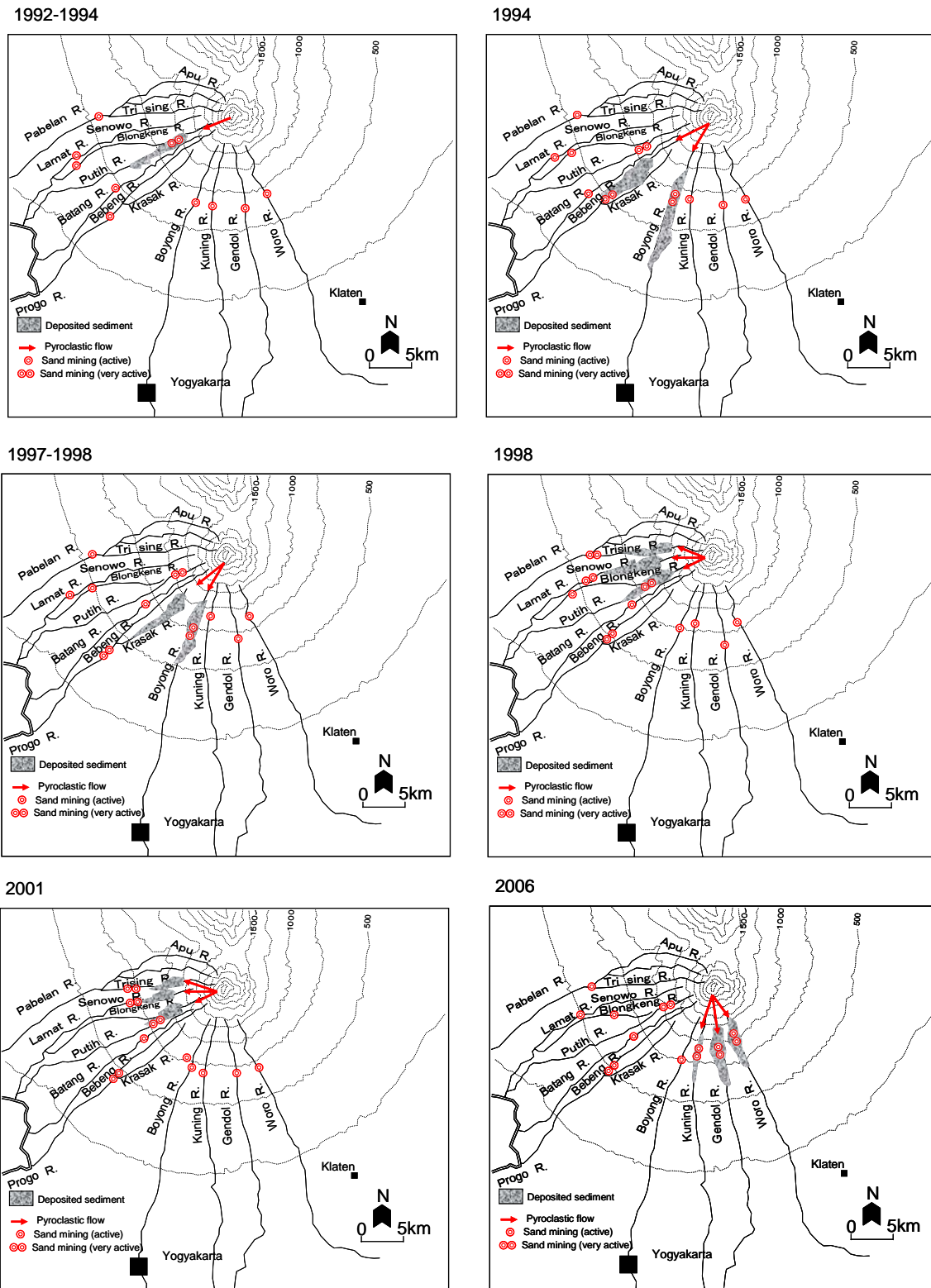

Fig. 3.18 Effects of Mount Merapi eruptions on sand mining activities from 1992 to 2006

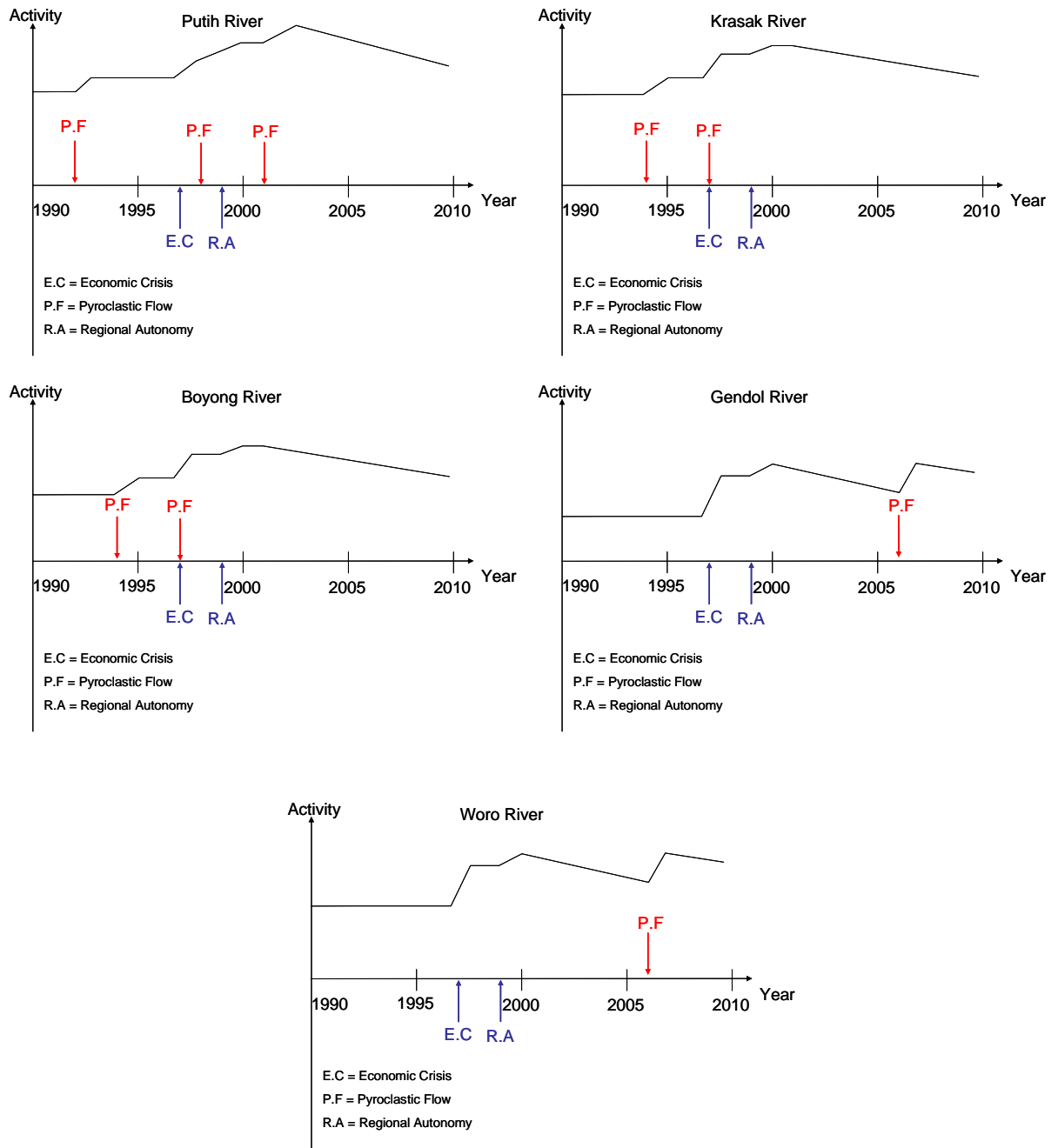

Fig. 3.19 Effects of pyroclastic flows, the economic crisis, and the regional autonomy on sand mining activities

(4) Sand mining control

To overcome the problem of negative effects of sand mining on the environment, government and non-government organizations have discussed the environmental issues. To prevent the sand mining exploitation, Indonesia government made the guidance by Directorate of Water Resources Decree No. 176/KPTS/1987. The decree consists:

- a) Recommendable exploitation locations are a stretch of river with aggradation/sedimentation area, inner curves, and sand pockets,
- b) Un-recommendable exploitation locations are at degradation area, outer curve, riverbank, and at a section between 500 m upstream and 1,000 m downstream from an existing structure,
- c) Depth of excavation depends on the type of material, thickness of deposits and river topographic conditions and,
- d) Exploitation by heavy industrial machine shall be considered and depends on type of materials, excavation volume, river topography, and allowable depth of deposits.

However, a number of companies and local people perform sand mining in restricted areas, which further causes the lowering of the riverbed near the river structure. Moreover, there have been no relevant licensing regulations, taxation, and control of sand mining. Hence, impact of sand mining control is very limited due to the lack of integrated management.

3.2.5 Effect of the previous sediment management

(1) Influence of sabo facilities

Indonesia has developed the sediment control (sabo) technology since 1970's, when the technical cooperation on the sabo technology between Indonesia Government and Japanese Government was established. After the large eruption in 1969, sediment control facilities were constructed to prevent sediment disasters.

For preventing sediment disasters, sabo works have been introduced in the areas where advantages have been given to the inhabitants who live in the disaster prone area. Debris flows have been recorded 64 times since 1981, but disasters

occurred only twice. This indicates that the sabo facilities have been effective in mitigating sediment disasters and have increased safety. The sabo facilities have also supported the regional development through equipped by irrigation intakes or transportation access. However, a careful consideration should be paid when the closed type of sabo dam is used. 87% of the existing sabo dams in Mount Merapi basin are the closed type. As a result, sabo dams would capture most of sediment and the sediment cannot flow into the downstream area directly. The deposited sediment attracts sand mining activities. Consequently, the sediment cannot reach the main rivers, resulting in the riverbed degradation. Other problems have occurred such as riverbank erosion and morphological changes; they produce negative effects on the ecology and on river structures in the downstream areas, including pier collapse and water intake blockage. Many researchers such as Kondolf (1997) have discussed about the effects of a dam. The effect of the sabo works facilities on socio-economic and environment are summarized in Figure 3.20 to Figure 3.22.

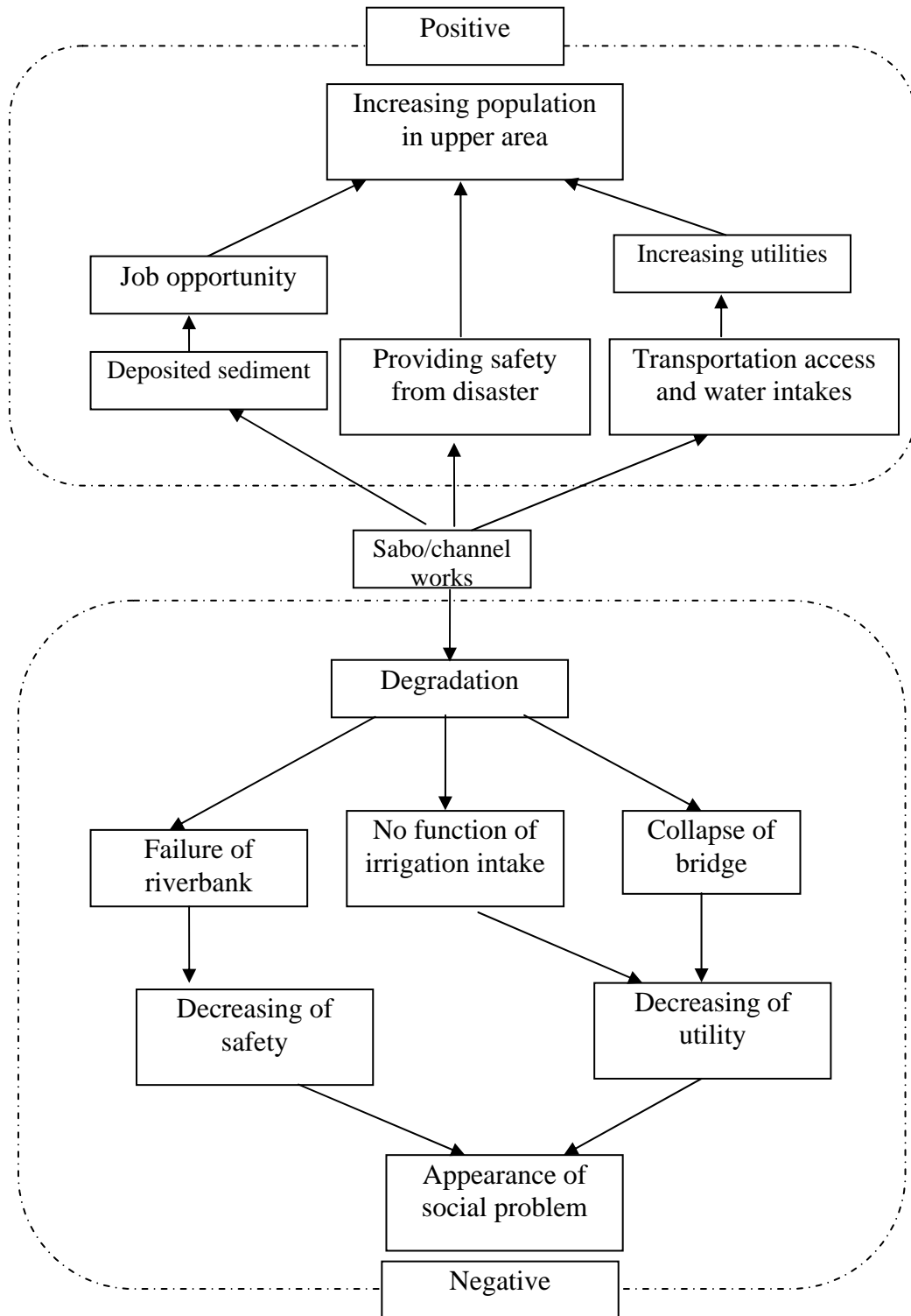

Fig. 3.20 A Diagram of influences of sabo/channel works on social aspect

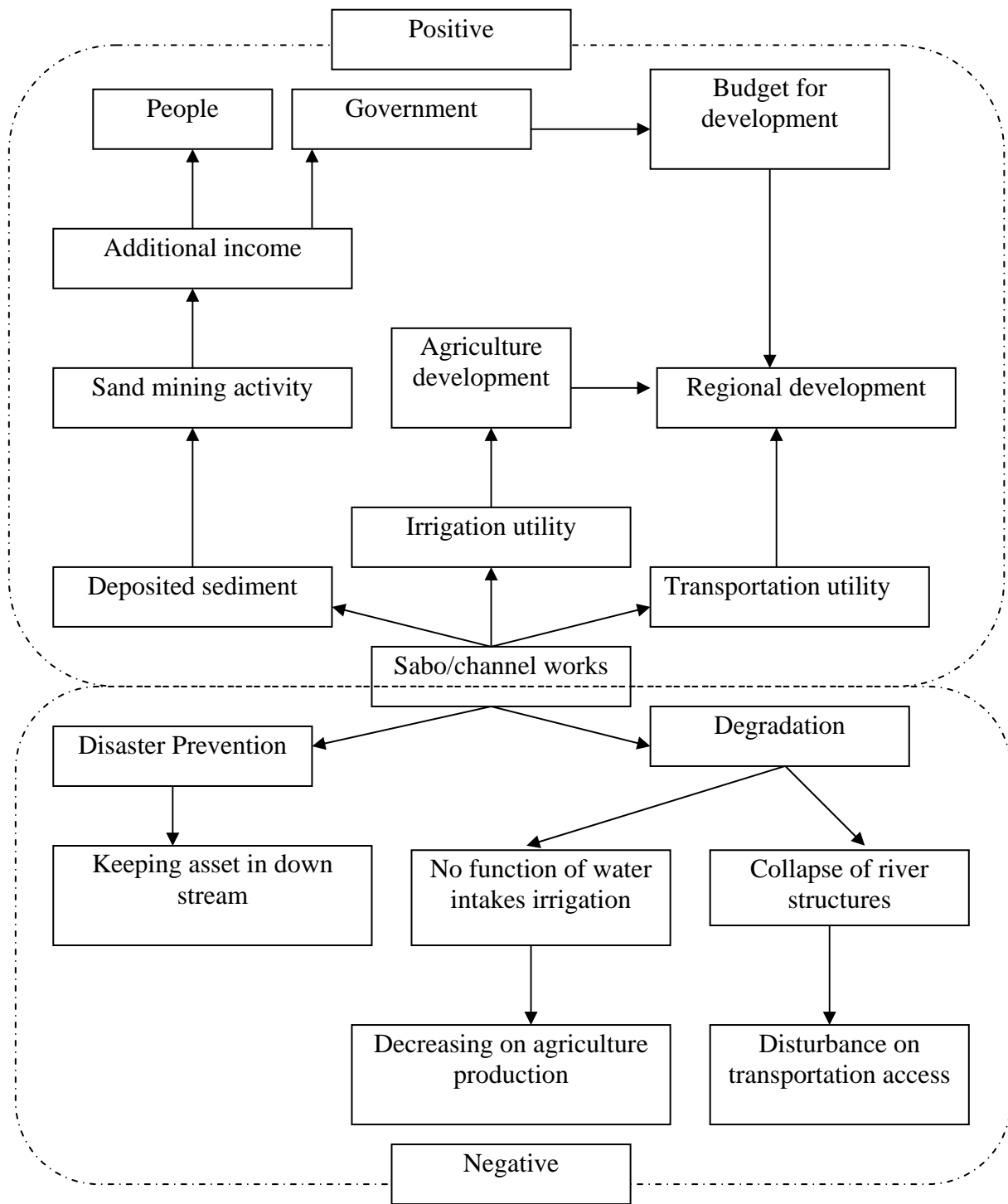

Fig. 3.21 A diagram of influences of sabo/channel works on economical aspect

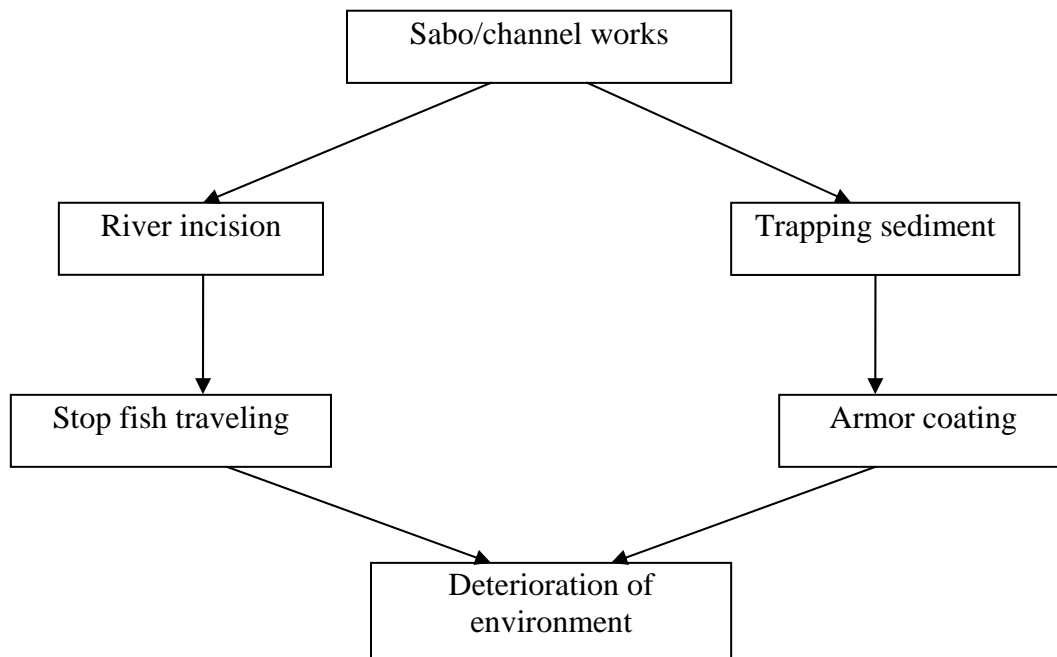

Fig. 3.22 A diagram of influences of sabo/channel works on environment

(2) Influence of sand mining

The sand and gravel produced by the eruptions of Mount Merapi has market value, and it attracts sand miners. The sand mining activities have given some advantages for rural/local people, local government, and reduction of sediment run off. Sand mining has a positive socio-economic impact in the Mount Merapi basin. First, the activity has provided job opportunities for local people and provided additional income from gravel mining and sales during the off-season of agriculture. In the foothills of Mount Merapi and the lower Progo River, approximately 21,022 and 1,235 people engage in sand mining every day, respectively (Sutiarno, 2006). The daily income of a sand miner ranges from 6000 to 36,000 rupiah (Aisyah, 2008). Sand mining has also provided tax for local governments. However, the uncontrolled sand mining has produced the following serious problems, as follows.

(a) Bed degradation

Referring to sub-section 3.1.2 about sediment balance in Mount Merapi basin, it indicates that the sediment output balances with the sediment input. Due to the excessive sand mining, riverbed degradation problems appear in Mount Merapi

basin. The most serious problem of bed degradation is happen in the Progo River. In upper area of the Progo River, there are rising danger of collapse check dam due to excessive sand mining. The bed degradation problems are explained as follows.

- Bridge

As an example of the damage to the bridge, a railway bridge collapsed at Comal River in 2001 due to the riverbed degradation. It is expected that it takes 6 months for the permanent countermeasure. The bridge is the only railroad line in north Indonesia (Semarang-Jakarta). Consequently the north line could not be fully operated, resulting in the economic loss of Rp. 300 million/day. The disaster shows the importance of bridge and magnitude of influence on the society. Bantar Bridge is very susceptible to collapse due to river degradation at the present. In the lower Progo River, there are three bridges, which are very important social infrastructures to connect the western and the eastern Java. They are Kebon Agung, Bantar and Srandakan bridges. Bantar Bridge is the most important, because it is one of the national transportation systems with the southern railway line and an oil pipeline. As if the three bridge collapse, a significant negative impact on society and economic will be given to Central Java and Yogyakarta Special Provinces. It means it is necessary to take immediate measures to stabilize riverbed in the Progo River.

-Irrigation

The agriculture is a main industry in Mount Merapi basin. Irrigation for paddy field is practiced intensively and extensively to support the self-sufficiency of main food (rice) in the region and nation. Stable supply of water is necessary to achieve the goal. However, the current situation shows that Sapon and Kamijoro irrigation intakes have difficulty to irrigate 4,500 ha of land due to the riverbed degradation. The issue hinders the agriculture and regional development.

Commonly, semi-technical and technical irrigation systems are dominant in the lower basin of the Progo River. Annual production with both systems is high compared with others, because the both are equipped with good facilities. Double cropping of paddy interspersed with maize is popular in those systems. The annual productions for technical and semi technical systems are 16.38 million rupiah/ha

and 14.76 million rupiah/ha, respectively. The annual production in total area irrigated by two intakes is approximately 66.4 billion rupiah. Unfortunately, the area is partially cultivated due to insufficient water. Hence, it is very important to re-function and stabilize Sapon and Kamijoro intakes to support the main industry and the regional development.

- Sabo dam

The one of positive function of sand mining is to recover the capacity of sabo dam and the activities seem to be appropriate if sand mining is conducted at upstream reach of sabo dam. Recently in the upstream of the Progo River, the sand mining is conducted in the downstream reach of the sabo dam, so that large amount of sediment is removed. The condition leads to the collapse of sabo dam.

(b) Social and environmental damages

Sand mining activity causes the noise and the dust in surroundings of the quarries, especially, if the activities are done in the night. Sand mining damages to the rural road due to overload of trucks along the sand mining route and gives pollution in the river due to the mining using a lot of heavy equipment. The other negative impacts are the destruction of ecosystems due to armoring on the bed surface in the downstream. The effects of sand mining activities on socio-economic and environment are summarized in Figure 3.23 to Figure 3.25.

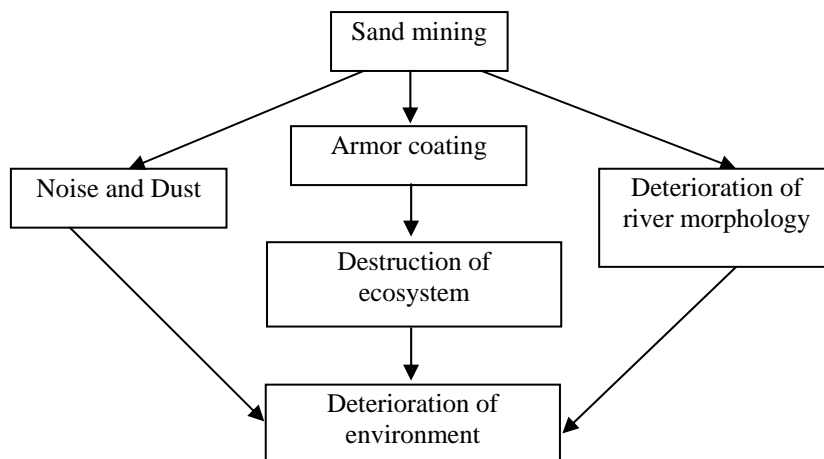

Fig. 3.23 A diagram of effect of sand mining activity on environment

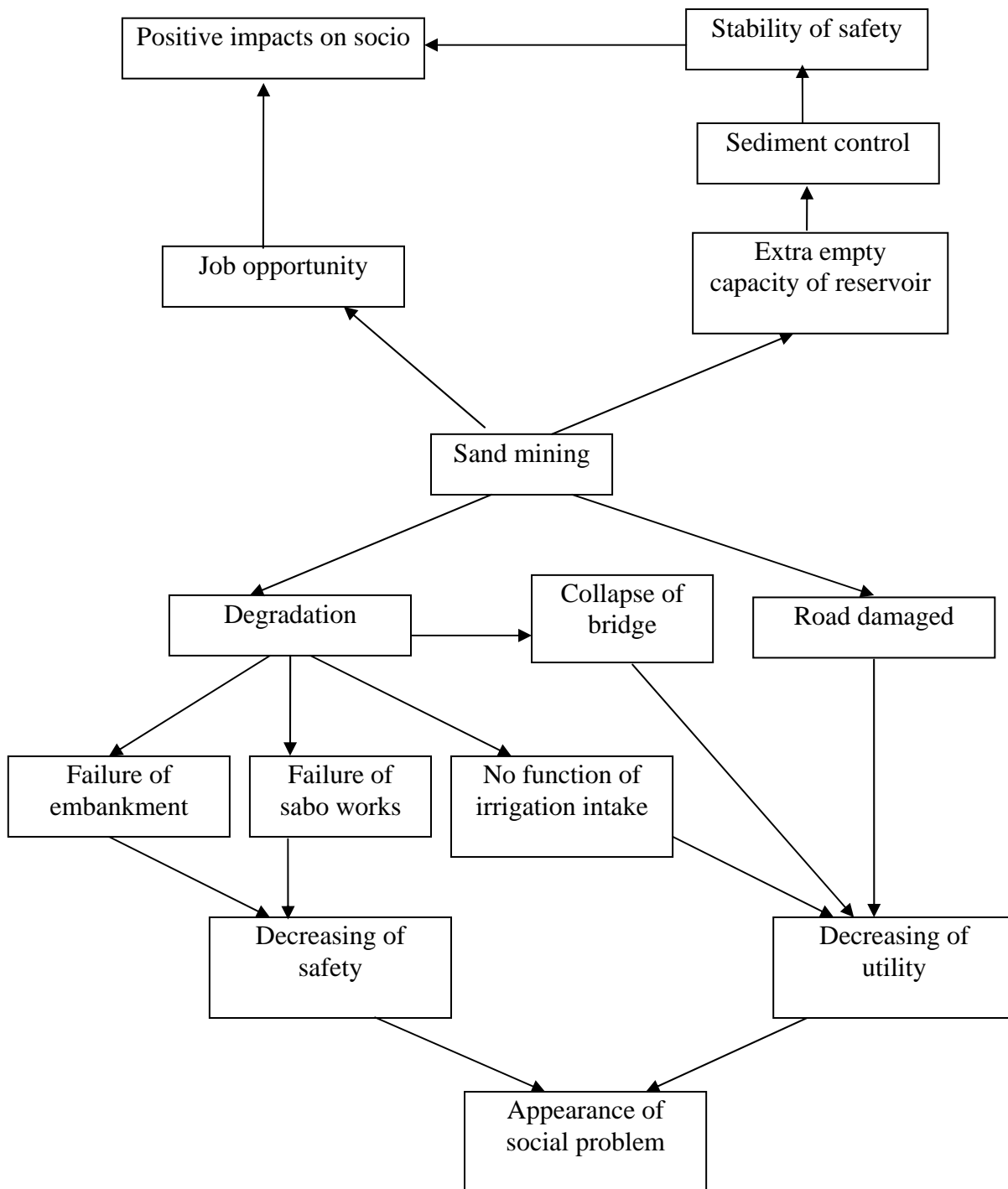

Fig. 3.24 A diagram of effect of sand mining activity on social aspect

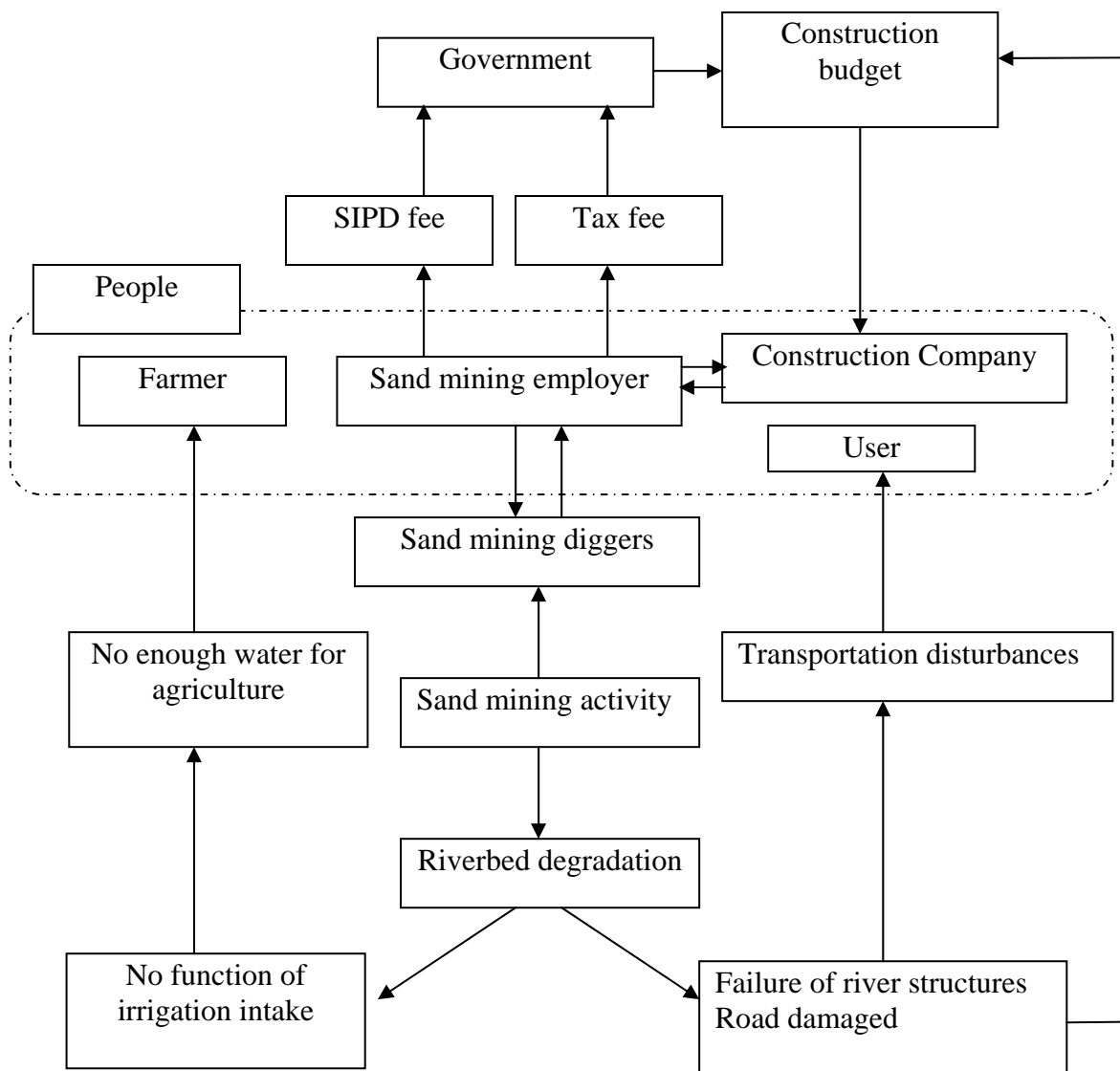

Fig. 3.25 A diagram of influences of sand mining on economic aspect

From the perspective of sediment resource management, people tend to take as much sediment as possible to support regional development. However, this gives negative impact on the environment and reduces the effectiveness of facilities disaster prevention. So far, in Mount Merapi basin, sediment disaster management and sediment resource management have been conducted separately.

3.3 Sustainable Sand Mining Management

3.3.1 Concept of sustainable sand mining management

Based on the background of socio-economic condition, the sand mining activities are difficult to be stopped. However, the activity also must be controlled, because another problem on sediment disaster has occurred in Mount Merapi basin. Author attempts to propose such sediment management. As shown in Figure 3.26, there are three aspects to be considered in sediment management, namely natural condition, socio-economical and technical aspects. It is important for the proposed management to satisfy effectiveness, feasibility, and sustainability. Sustainability in this paper means that the resource and the safety aspects can be maintained with considering sediment production (natural condition), resources utilization for supporting socio-economic and environment conservation as well as disaster mitigation. In this section, the basic concept of sustainable sediment management based on sand mining regulation, channel works, and sabo works is described.

Roughly, an unsustainable situation is explained in Figure 3.27. This figure shows the time variation of safety level and sediment resources amount in a basin. After an ordinal eruption, safety level decreases, but it could be easily recovered by sabo works. Sediment resources could be also recovered a little bit, but active sand mining completely consumes it soon. Even if the safety level rises up due to sabo works, it turns to fall down again because of excess sand mining. After huge eruption, safety level falls down quickly and seriously, and the severe bed aggradation takes place in the basin. As an ordinal eruption case, sabo works increase the safety level. If sand mining is appropriately regulated, the safety level is kept higher. However, huge eruption could accelerate sand mining activity very much without any control. As a result, the safety level cannot increase so much and rather decrease.

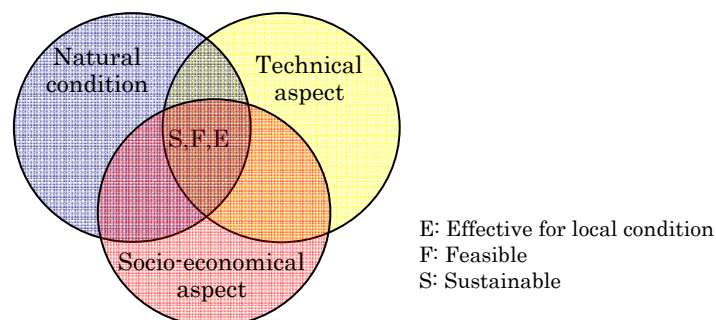

Fig. 3.26 Aspects to be considered in sediment management

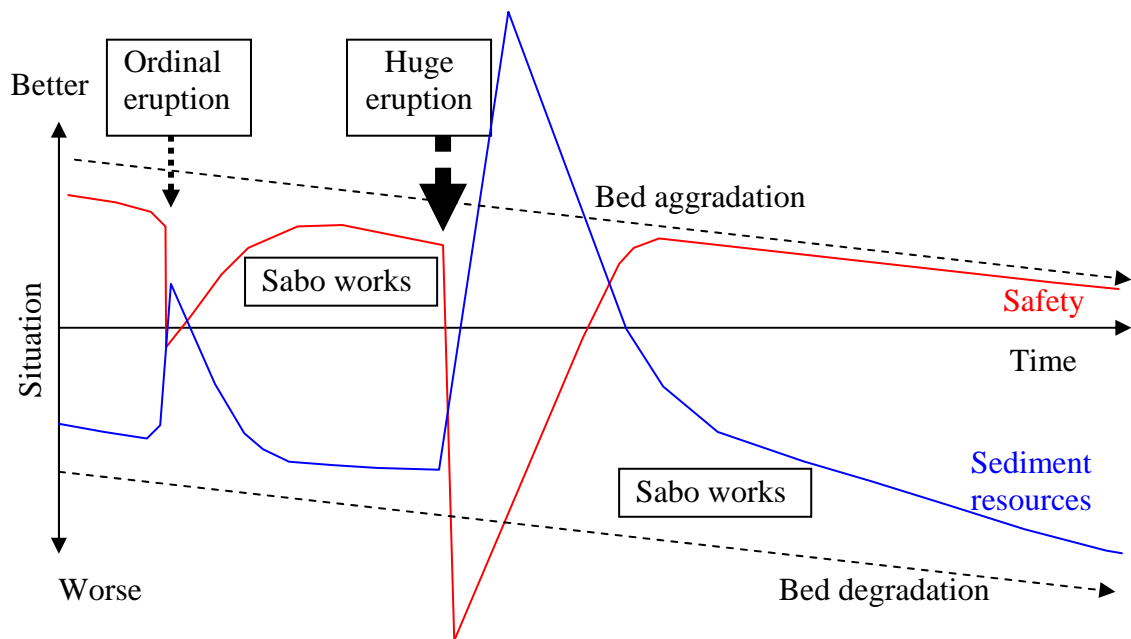

Fig. 3.27 Unsustainable condition of sediment resources and safety aspects

Figure 3.28 explained a sustainable situation. To achieve the condition, the combination among sabo works, channel works, and sand mining control can be used. Without eruption from Mount Merapi, the safety of inhabitants or stability of river facility structures can be maintained as long as the sand mining is controlled. To stabilize the function of the river facility structures, the channel works installation can be done in order to keep riverbed from degradation. Before eruptions, the controlled sand mining can be used as a tool to empty the deposited sediment in check dams. The capacity of check dam will be increased again against the next sediment disaster. So that, when a huge eruption occurs, check dams with recovered capacity can function effectively against the sediment/mass movement. The produced sediment might threaten the inhabitants, but the threatening does not seem so serious. The safety level will certainly decrease, but it could be not severe. New sabo work project increases the safety level. If the sand mining is appropriately controlled, the safety level is kept higher and sediment resources are conserved. By such management, the basin situation could become sustainable.

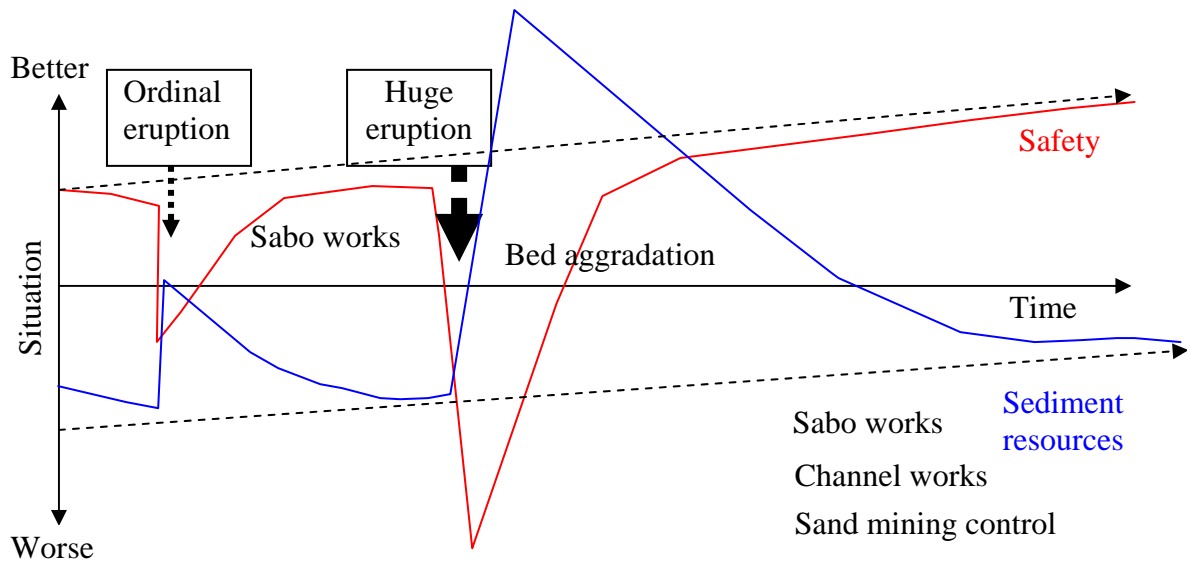

Fig. 3.28 Sustainable condition of sediment resources and safety aspects

3.3.2 Allowable sand mining volume in Mount Merapi basin

The sand mining activities are prospering around Mount Merapi, but sustainable sand mining management is strongly required. The success in sustainable sand mining management is dependent on how to determine the allowable sand mining volume in the upper area around Mount Merapi. To determine the allowable sand mining volume, the following steps are necessary to do. Figure 3.29 shows the steps for determining the allowable sand mining volume.

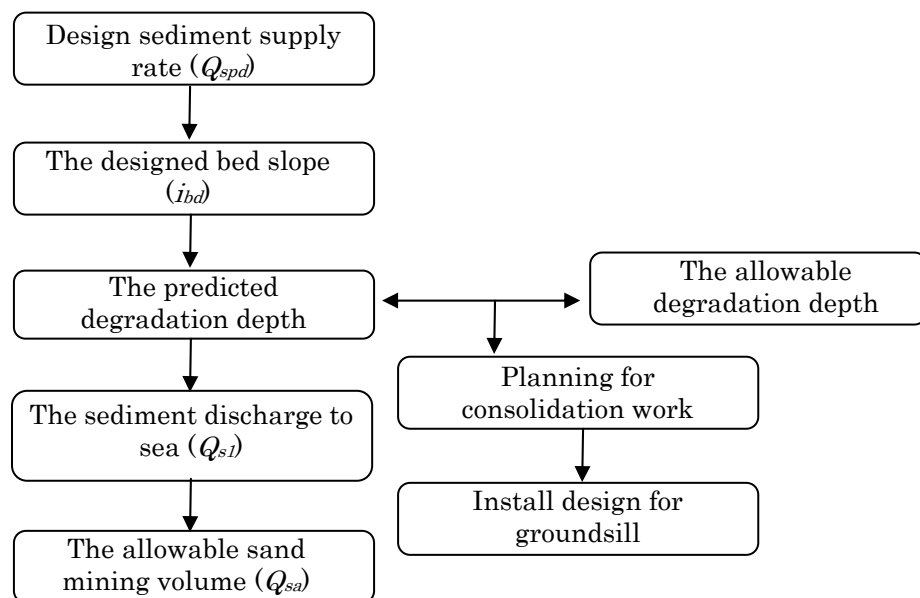

Fig. 3.29 Flow chart to determine the allowable sand mining volume

First, the designed bed slope in the lower reach, i_{bd} , is decided. In consequence of first step, it is necessary to estimate how many groundsills must be installed. If the designed bed slope is quite less than the original bed slopes, the number of groundsills becomes larger. Next step, sediment discharge to sea, Q_{s1} , is calculated for the designed bed slope. Finally, the allowable sand mining volume, Q_{sa} , can be calculated upon the design sediment supply rate, Q_{spd} , and the sediment discharge to sea as follows.

$$Q_{sa} = Q_{spd} - Q_{s1} \quad (3.1)$$

If sand mining rate is larger than Q_{sa} , the river becomes unstable because of severe degradation or more groundsills are necessary. However, it is difficult to install more groundsills due to the limited budget of the government. Therefore, sand mining control is a reasonable method to achieve the purpose of sustainable sediment management. If sand miners follow this regulation, sand mining could be continued keeping the river stable.

The allowable sand mining volume could be predicted based on the designed bed slope, i_{bd} . The relationship between the allowable sand mining volume, Q_{sa} , and the designed bed slope, i_{bd} , is obtained as follows. The annual average sediment production rate, Q_{spm} , in Mount Merapi basin is estimated at 1.44×10^6 m³/year. How to calculate the annual average sediment production rate, Q_{spm} , was explained in sub-section 3.1.2. Then assumed that Q_{spd} is equal to Q_{spm} (1.44×10^6 m³/year), Q_{sa} is expressed by $Q_{spm} - Q_{s1}$. For instance, if the designed bed slope is 0.0015, the sediment discharge to sea, Q_{s1} , is 1.46×10^6 m³/year. Thus, under this condition, the allowable sand mining volume is around zero. If the designed bed slope is 0.0010, the sediment discharge to sea is 0.78×10^6 m³/year, and therefore the allowable sand mining volume is estimated at 0.66×10^6 m³/year. Relation between i_{bd} and the allowable sand mining volume, Q_{sa} , is shown in Figure 3.30. In the Mount Merapi basin, the maximum allowable sand mining volume is limited to 1.44×10^6 m³/year which is the annual sediment production supplied from Mount Merapi volcanic and non volcanic basin.

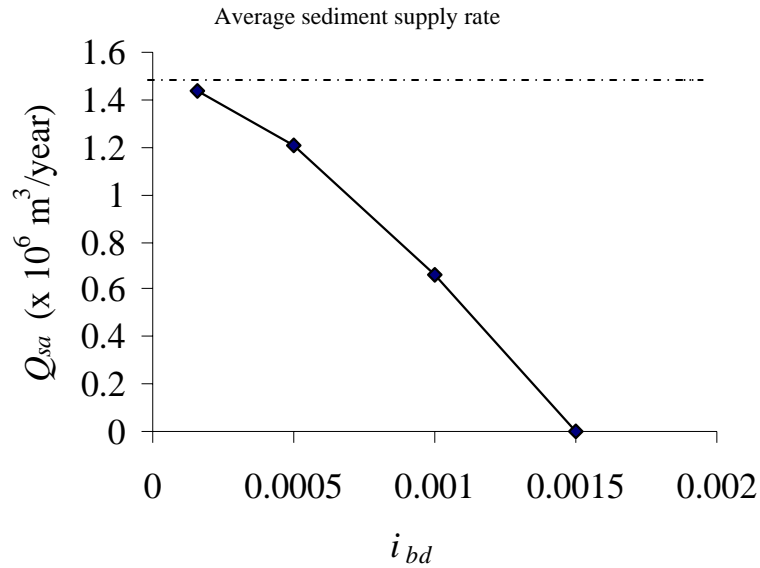

Fig. 3.30 Relationship between the designed bed slope and the sand mining volume

However, the sediment supply rate, Q_{supply} , from the Mount Merapi changes very much. Thus, it is very important to determine the allowable sediment supply to the lower Progo River, Q_{s2} , for each i_{bd} to prevent sediment hazard. Here, it is assumed that Q_{s2} is defined as sediment supply rate that causes i_{bd} to return to the original bed slope ($i_b = 0.0015$). Q_{s2} is equal to $Q_{spm} + Q_{sa}$. For example, if the designed bed slope is 0.001, Q_{s2} is $2.06 \times 10^6 (= 1.44 \times 10^6 + 0.62 \times 10^6) \text{ m}^3/\text{year}$. Relation between i_{bd} and Q_{s2} is shown in Figure. 3.31. If Q_{supply} is less than or equal to Q_{s2} , series of groundsill is never buried with sediment. However, if Q_{supply} is much larger than Q_{s2} , it will cause bed aggradation and groundsills are completely buried after a long time. For example, if a huge eruption occurs with the sediment production rate of $25.0 \times 10^6 \text{ m}^3/\text{year}$ like 1930, it is predicted that the bed slope changes from i_{bd} to the equilibrium bed slope. If the bed increases rapidly, it can cause some serious problems in the lower reach such as ineffectiveness of irrigation intake function. Considering the actual situation of the volcanic activities in Mount Merapi, a buffer zone such as a sand pocket is strongly required.

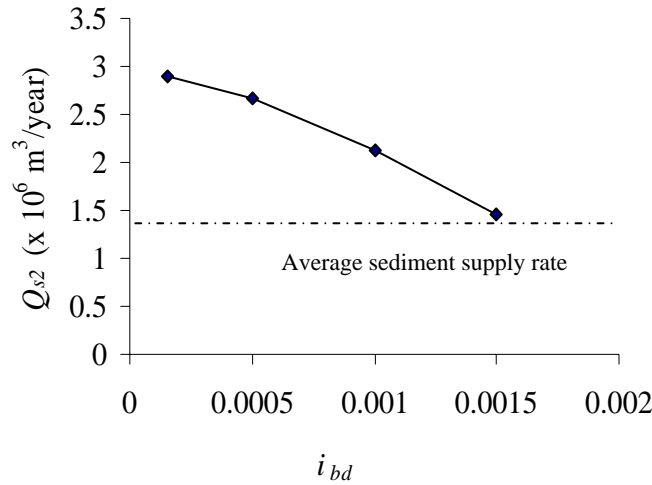

Fig. 3.31 Relationship between the designed slope and the allowable sediment supply

3.4 Sustainable Management Combined With Consolidation Works

Sand mining management concept in Mount Merapi basin is discussed in **Sub-section 3.3.2**. However, the concept is established under equilibrium sediment transport condition. In this section, one dimensional bed deformation analysis is performed for the lower reach of the Progo River and two management concepts on the sand mining and the groundsill installation are discussed.

3.4.1 Simulation model

The basic equations of one dimensional bed deformation analysis are shown as follows. The used model is the standard well-used one dimensional bed deformation model. Mass and momentum equations of water are as follows.

$$\frac{\partial A}{\partial t} + \frac{\partial Q}{\partial x} = 0 \quad (3.2)$$

$$\frac{\partial Q}{\partial t} + \frac{\partial}{\partial x} \left(\frac{Q^2}{A} \right) = -gA \frac{\partial z}{\partial x} - gAI_e + \frac{\partial}{\partial x} (A\sigma_{xx}) \quad (3.3)$$

where, t is the time, x is the coordinate along the longitudinal direction, A is the cross-section area of water, Q is the water discharge in main channel, g is the

gravity, ρ is the water density, z is the water surface elevation, I_e is the energy slope and σ_{xx} is the turbulence stress. I_e is obtained by using of Manning's friction law as follows:

$$I_e = \left(\frac{n_m Q}{h^{2/3} A} \right) \quad (3.4)$$

where, n_m is the Manning's roughness coefficient. The following relationship is used for the turbulence stress σ_{xx} .

$$\sigma_{xx} = 2\nu \frac{\partial}{\partial x} \left(\frac{Q}{A} \right) \quad (3.5)$$

$$\nu = \frac{\kappa}{6} u_* h \quad (3.6)$$

Therein ν is the kinematic eddy viscosity. Ashida and Michiue's formula is used for the estimation of sediment transport rate in which the effect of local bed slope on the critical shear stress is considered.

$$Q_{bk} = B_w 17 \sqrt{sg} d_k^3 \tau_{*e}^{3/2} \left(1 - \sqrt{K_c \frac{\tau_{*ck}}{\tau_{*k}}} \right) \left(1 - K_c \frac{\tau_{*ck}}{\tau_{*k}} \right) f_{mk} \quad (3.7)$$

where, B_w is the total channel width of water in a cross-section, s is the specific weight of sediment in water, d_k is particle size of k sediment class, τ_{*e} is the non-dimensional effective shear stress, τ_{*k} is the non-dimensional shear stress of k sediment class, τ_{*ck} is the non-dimensional critical shear stress of k sediment size class, K_c is the correction function of the critical shear stress and f_{mk} is the sediment concentration of size class k in wetted region. τ_{*ck} is estimated by using of modified Egiazaroff equations as follows.

$$\tau_{*ck} = \tau_{*cm} \left[\frac{\log_{10} 19}{\log_{10}(19d_k / d_m)} \right] \quad d_k/d_m \geq 0.4 \quad (3.8)$$

$$\tau_{*ck} = 0.85 \tau_{*cm} \frac{d_m}{d_k} \quad d_k/d_m < 0.4 \quad (3.9)$$

where, τ_{*cm} is the non dimensional critical shear stress of mean diameter of bed material. Iwagaki's formula is used for evaluating τ_{*cm} for uniform bed material, as follows.

$$u_{*cm}^2 = 80.9d_m \quad d_m \geq 0.303 \quad (3.10)$$

$$u_{*cm}^2 = 134.6d_m^{31/22} \quad 0.118 \leq d_m < 0.303 \quad (3.11)$$

$$u_{*cm}^2 = 55.0d_m \quad 0.0565 \leq d_m < 0.118 \quad (3.12)$$

$$u_{*cm}^2 = 8.41d_m^{11/32} \quad 0.0065 \leq d_m < 0.0565 \quad (3.13)$$

$$u_{*cm}^2 = 226d_m \quad d_m < 0.0065 \text{ (Unit : cm)} \quad (3.14)$$

$$\tau_{*cm} = \frac{u_{*cm}^2}{sgd_m} \quad (3.15)$$

τ_{*ek} is the non dimensional effective shear stress of k sediment size class which is evaluated as follows.

$$u_{*em} = \frac{Q}{A \left(6 + 2.5 \ln \frac{h}{d_m (1 + 2\tau_{*m})} \right)} \quad (3.16)$$

$$\tau_{*ek} = \frac{u_{*em}^2}{(sgd_k)} \quad (3.17)$$

K_c is the correction function of the critical shear stress as follows:

$$K_c = 1 + \frac{1}{\mu_c} \left(\frac{\rho}{s} + 1 \right) \tan \theta_x \quad (3.18)$$

where, μ_c is the static friction coefficient, θ_x is the bed slope along longitudinal direction.

Continuity equation of sediment discharge is:

$$B_w \frac{\partial z_b}{\partial t} + \frac{1}{1-\lambda} \frac{\partial Q_b}{\partial x} = 0 \quad (3.19)$$

where, B_w is the channel width, λ is the porosity of bed material, z_b is the riverbed elevation.

3.4.2 Simulation using uniform sediment

(1) Hydraulic conditions

The simulation is carried out using the averaged geometric and hydraulic characteristic values of the lower reach of the Progo River. These data are the same as the data used in Section 3.1.2. Discharge is equal to the annual average discharge of 83.1m³/s. The mean diameter of bed material is 1 mm, river width in the calculation is the average river width of 200 m, and the initial bed slope is the average bed slope of 0.0015. The calculation length is 30 km. Normal water depth is used for the downstream boundary conditions. The simulation conditions are summarized as shown in Figure 3.32. The bed material is treated as uniform sediment with the mean diameter of 1 mm. The sediment management here is simulated under some scenarios that shown in Table 3.7. In Case 1, the bed variation was simulated under a natural condition, i.e., without management or sand mining. The sediment management by sand mining activity was considered in Case 2. In Case 2a, the volume of sand mined was the same as the annual average of sediment production volume. In Case 2b, the volume of sand mined was 50% of the annual average of sediment production volume. The variation in the riverbed was simulated considering the installation of channel works (groundsills) and sand mining in Case 3. The height of each groundsill was 2.7 m, and the longitudinal interval between groundsills was 9 km. In Cases 3a and 3b, 100% and 50% of the annual average of sediment production volumes were mined, respectively.

Table 3.7 Scenarios of proposed sediment management

Cases	Sediment Control Structure	Sand mining volumes (m³/year)
1	No	No
2.a	No	1.44x10 ⁶
2.b	No	0.72x10 ⁶
3.a	Groundsills	1.44x10 ⁶
3.b	Groundsills	0.72x10 ⁶

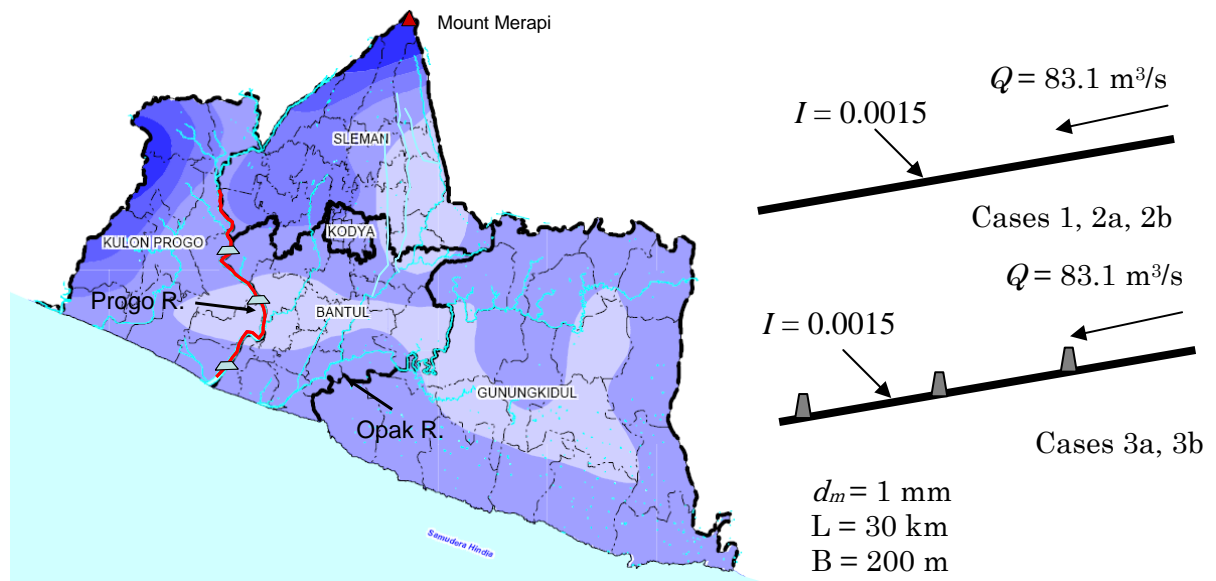

Fig. 3.32 Simulation conditions using uniform sediment

(2) Result and discussion

Figure 3.33 shows the simulation results in Cases 1, 2a and 2b. If the sediment supply from the upstream area is equal to the annual average sediment production, the riverbed can be stabilized. It means no aggradation and no degradation in Case 1, so the equilibrium state will be achieved. The equilibrium condition will change if the sediment supply from the upstream also changes due to a natural or human activities. Riverbed degradation will take place in the downstream area due to the decrease in the sediment supply caused by the human activities in the upstream area, such as a sand mining activity. If the sediment mining is equal to the annual sediment production as presented in Case 2a, the riverbed degradation in the upstream boundary end is estimated at about 12.93 m during 10 years. The condition can be used to describe the current situation of the riverbed condition in the lower reach of the Progo River, where the riverbed degradation is very serious due to the sand mining activities in the foothill of the Mount Merapi as well as along the Progo River. Hence, the sand mining activities is necessary to be controlled. The controlled sand mining can reduce the riverbed degradation at the point, as described in Case 2b. If the sediment mining volume is equal to a half of the annual sediment production, the riverbed degradation can be reduced to become 6.29 m in the same period.

Figure 3.34 shows the simulation results for Cases 3a and 3b. A combination between sand mining management and the groundsill installation is used to overcome the bed degradation in the downstream area. In Case 3a, if the all of the sediment production is mined, the degradation at the upstream end is estimated at about 8.52 m during a period of 10 years. In the upstream part of a groundsill, riverbed can be increased and stabilized by the groundsill. However, in the downstream part of the groundsill, the riverbed degradation is very severe. For example, at the downstream part of the third groundsill, the riverbed degradation takes places about of 5m. In Case 3b, if the sand mining volume is equal to half of the annual average of sediment, the degradation at the upstream end reaches 3.55 m during 10 years. The degradation will stop if the new equilibrium condition is reached. The results indicate that the installed groundsills can reduce the rate of the degradation depth at the location. By the groundsill installation, the bed slope between the two groundsills becomes milder, so the sediment discharge to downstream area decreases as well as the bed degradation rate. Moreover, the riverbed can be stabilized by the structures. Hence, to overcome the riverbed degradation in the downstream of Progo River, it needs combination between the channel works and the sand mining management.

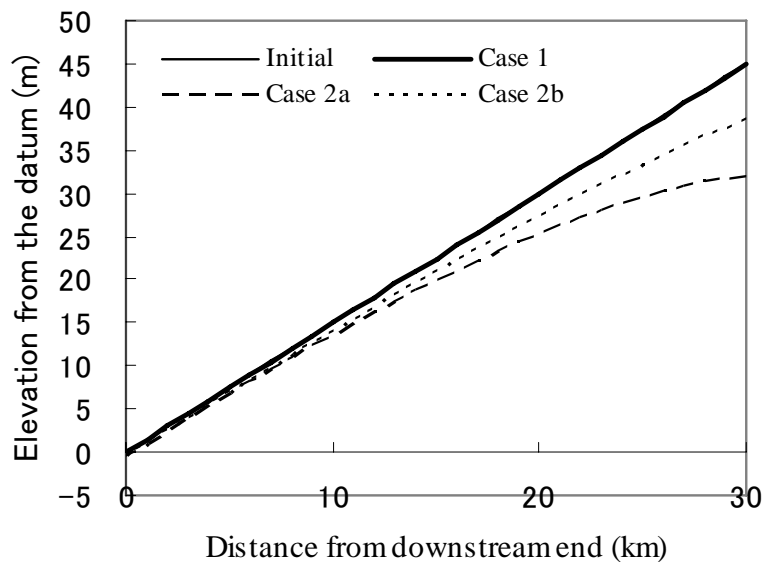

Fig. 3.33 Riverbed variation in Cases 1, 2a and 2b in a period of 10 years with uniform sediment

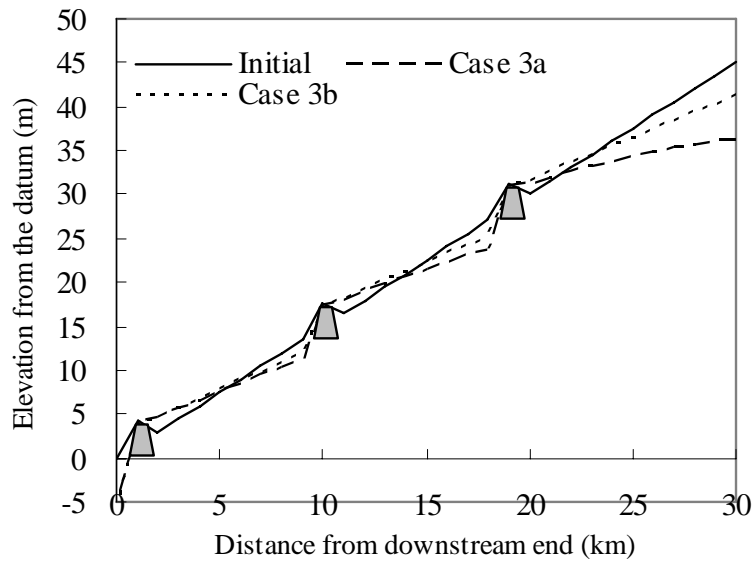

Fig. 3.34 Riverbed variation in Cases 3a and 3b in a period of 10 years with uniform sediment

(3) The policy on the groundsill installation

(a) Hydraulic conditions

The method for installing the groundsills and the maximal capacity of sediment discharge in channels will be discussed. The simulation is carried out using the averaged geometric and the hydraulic characteristic values of the lower reach of the Progo River. These data are same as the data used in sub-section 3.4. 2. The bed material is treated as uniform sediment. Calculations are performed under 6 conditions. The initial longitudinal bed geometry is presented in Figure 3.35.

In Case 1, initial bed lope is 0.0015 and 3 groundsills are installed on the original bed. The height of each groundsill is 2.7m and the longitudinal interval between groundsills is 9km. Under this groundsill install condition, the designed bed slope becomes 0.0012. Supplied sediment discharge is the equilibrium sediment transport rate with the slope of 0.0012 ($= 0.0338\text{m}^3/\text{s}$).

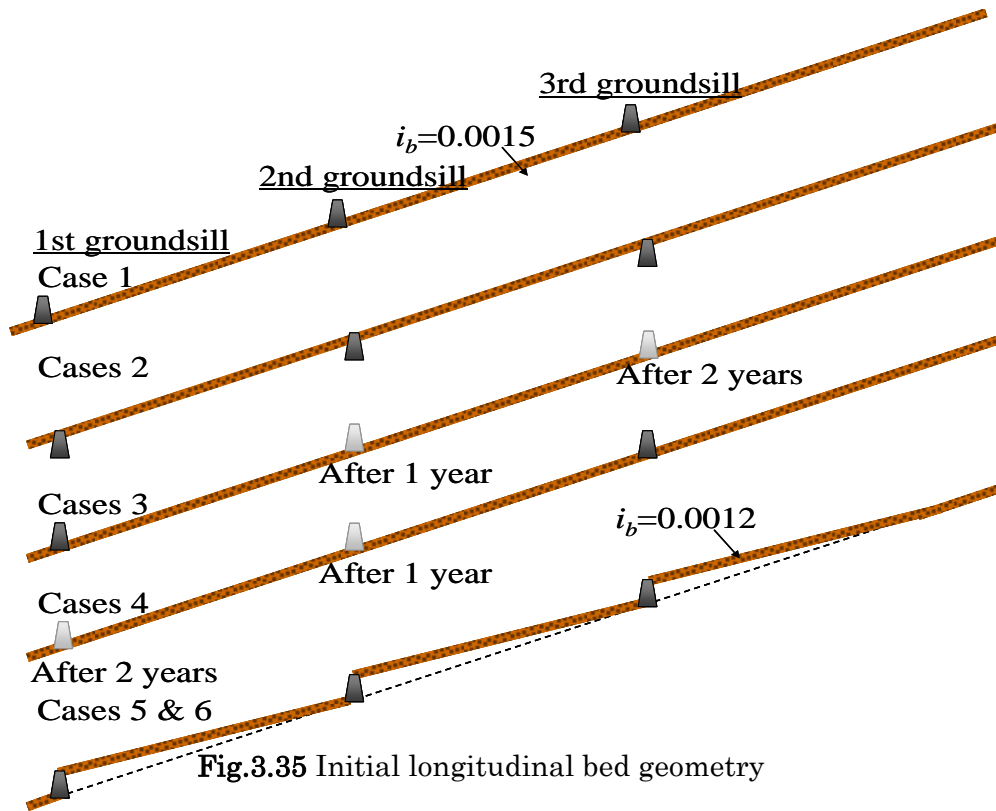

Fig.3.35 Initial longitudinal bed geometry

In Case 2, the hydraulic condition is the same as that in Case 1 except for the installation level of groundsills. The crest of groundsills has the same level as the bed surface. When the bed has been degraded because of sand mining and so on, groundsills will be installed as Case 1 to increase the bed surface. When the initial bed level should be kept, groundsills will be installed as Case 2. Cases 3 and 4 will be used for the discussion on the installation order of groundsills. Only 1st groundsill is installed as an initial condition in Case 3 and the 2nd groundsill and the 3rd groundsill are installed after 1 year and 2 years, respectively. The other hydraulic condition is the same as that in Case 1. Only 3rd groundsill is installed as an initial condition in Case 4 and the 2nd groundsill and the 1st groundsill are installed after 1 year and 2 years, respectively. The other hydraulic condition is the same as that in Case 1.

Bed variation characteristics under large sediment supply conditions are discussed using Cases 5 and 6. The initial bed slope between groundsills is 0.0012. In Case 5, the supplied sediment discharge during the first year is the same as the

sediment discharge in the 1930's huge eruption ($= 0.790\text{m}^3/\text{s}$). Supplied sediment discharge in the following 4 years is the equilibrium sediment transport rate with the slope of 0.0012. In Case 6, the supplied sediment discharge during the first year is twice as the equilibrium sediment transport rate with the slope of 0.0015 ($= 0.0463\text{m}^3/\text{s} \times 2$). Supplied sediment discharge in the following 4 years is the equilibrium sediment transport rate with the slope of 0.0012.

(b) Results and discussion

Figure 3.36 (a) shows the temporal change of bed geometry in Case 1. The bed deformation between groundsills is very fast and bed slope becomes mild with time. Bed level at 18km from the downstream end decreases with time in the first year and increases in the following years. Figure 3.37 (a) shows the temporal change of the sediment transport rate between the 2nd groundsill and the 3rd groundsill in Case 1. The Figure indicates that the bed at 18km is degraded until 8 months, because the sediment transport rate at 18km is more than sediment transport rate at 19km. These results indicate that the bed deformation between groundsills in the first year is the adjustment process of bed geometry to the local flow condition. On the other hand, after 8 months, sediment deposition takes place at 18km due to the effect of the upstream sediment supply conditions. The sediment transport rate at 10km is still smaller than the equilibrium sediment transport rate with the bed slope of 0.0012 ($= 0.0338\text{m}^3/\text{s}$) at 5 years. Hence, approaching to the equilibrium state takes very long time under this condition.

Figure 3.36 (b) shows the temporal change of bed geometry in Case 2. The bed degradation in the downstream of 3rd groundsill is invisible after 1 year. This result indicate that the effect of small sediment supply condition ($= 0.0338\text{m}^3/\text{s}$) propagates to downstream very slowly. Here, let me try to use the very slow propagation velocity to decide the installation order of groundsills. In Case 2, the 3 groundsills are installed at time as the initial condition. However, in order to save budget (including interest for the budget), we had better construct only one groundsill first and the others are constructed at the following appropriate year. Figure 3.37 (b) shows the temporal change of the sediment transport rate on 3 groundsills in Case 2. Sediment transport does not decrease on the 2nd groundsill

and the 1st groundsill until 2 years and 4 years, respectively. As a result, if installation of crest of groundsill is the same as the bed surface to keep the original bed, not to increase the original bed, installation of the 2nd groundsill can be done at the 2 years and installation of the 1st groundsill is at the 4 years. It is economical that the groundsills are installed from upstream to downstream.

Figure 3.36 (c) and (d) show the temporal change of bed geometry in Cases 3 and 4. Comparing among Cases 1, 3 and 4, bed degradation at the downstream of groundsills (ex. 18km and so on) is suppressed in Case 3. Hence, the groundsills in Case 3 are the most stable and the depth of the basement under the bed can be shallow. As a result, the construction costs of groundsills can be saved. Figure 3.37(c) shows the temporal change of the sediment transport rate at the downstream end. In order to minimize the impact of groundsill construction on the ecosystem of the downstream of groundsills, the decrease range of sediment discharge should be smaller. From the view point of this, Case 3 has the smaller temporal change of sediment discharge (initial sediment transport is $0.0457\text{m}^3/\text{s}$). Hence, when groundsills are installed to increase the bed level (the crest of groundsills is higher than the bed surface), it is safe for human being, plants and animals that the groundsills are installed from downstream to upstream.

Figure 3.36 (e) shows the temporal change of bed geometry in Case 5. Bed elevation from 25km to 30 km becomes very high after 1 year and overbanked sediment flood is expected. After 5 years, all the groundsills are filled with sediment and the slope becomes larger than 0.0015. Of course, these results depend on the upstream sediment supply condition. However, the data of the upstream of the Progo River is not enough to discuss the propagation characteristics of sediment supply by the volcanic eruption. Hence, the above mentioned sediment supply condition is applied as an example here. Figure 3.36(f) shows the temporal change of bed geometry in Case 6. As shown in Figure 3.36 (f), the bed deformation around the groundsills is very small because of the decrease in the sediment discharge peak during the propagation process to downstream. Hence, the allowable maximum discharge is underestimated, when the equilibrium conditions is assumed. As a result, the two times as the equilibrium sediment transport rate with the slope 0.0015 can be flowed without filled with groundsills.

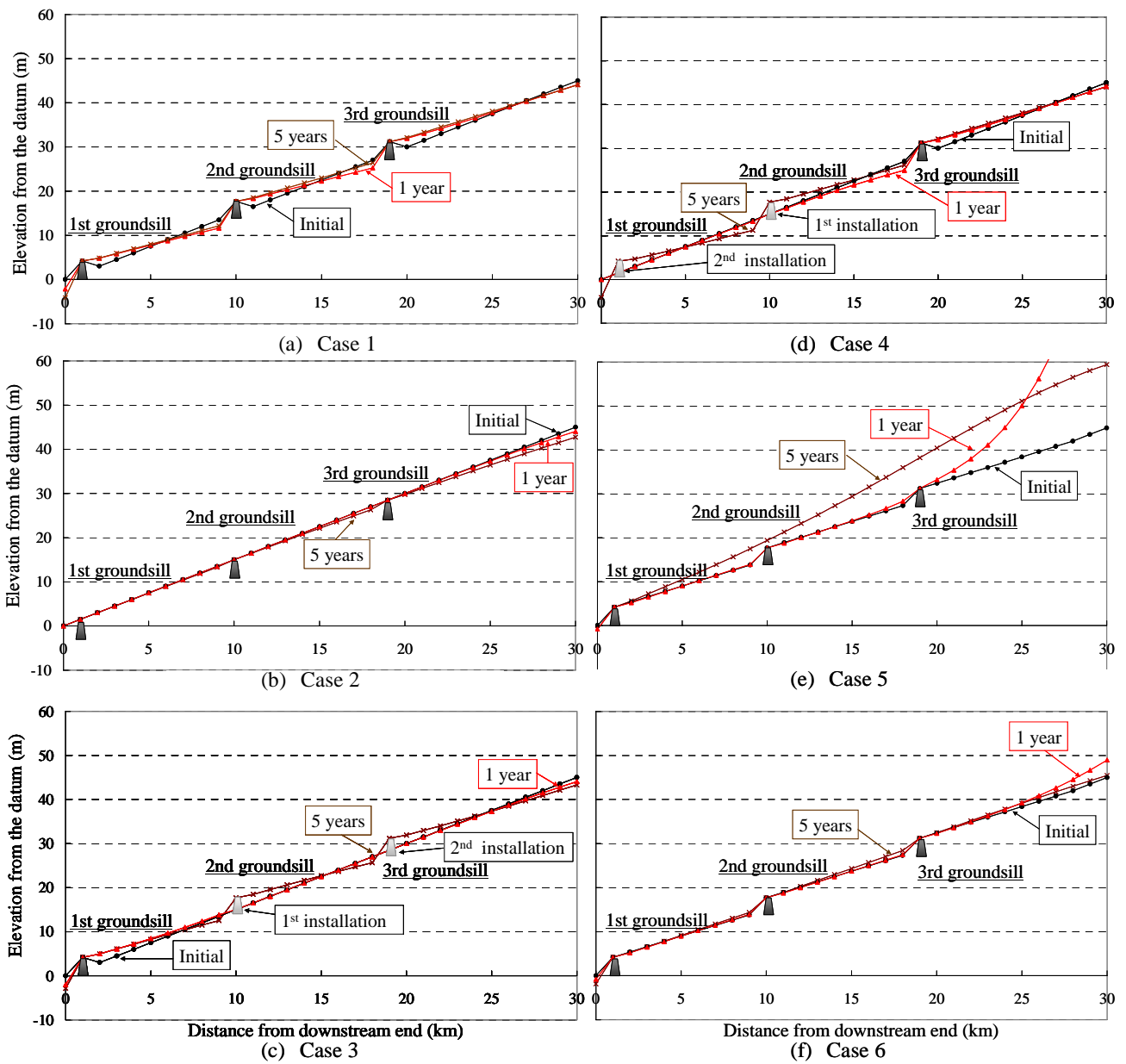

Fig. 3.36 Temporal change of bed geometry using uniform sediment

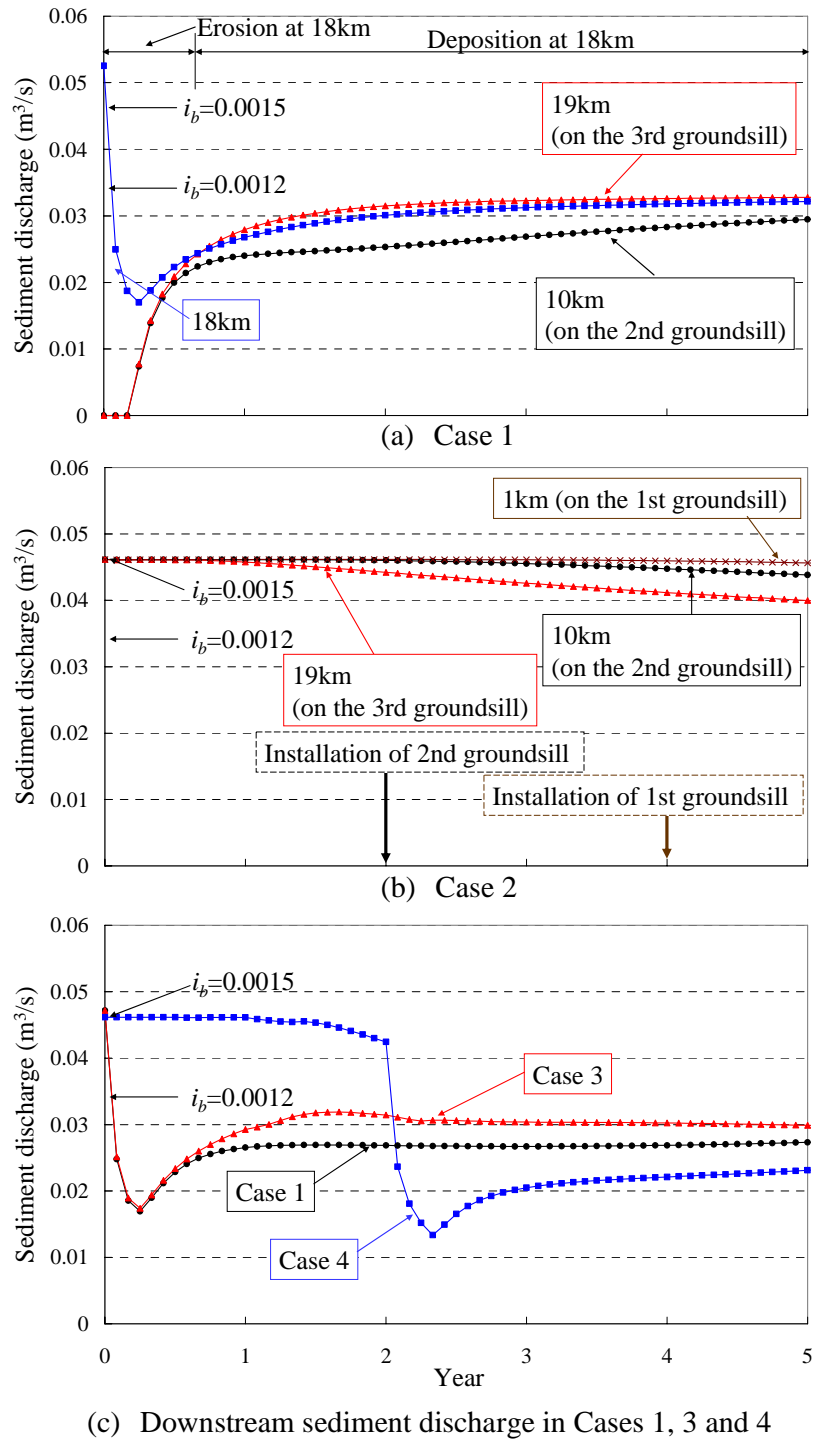

Fig. 3.37 Temporal change of sediment transport rate using uniform sediment

3.4.3 Simulation using non-uniform sediment

(1) Hydraulic Conditions

Simulation in sub-section 3.4.2 is conducted with the initial bed material using uniform sediment. In this section, simulation using non-uniform sediment will be discussed. The hydraulic conditions are as follows. The water discharge is the annual average discharge ($83.1\text{m}^3/\text{s}$); the river width is the average river width (200 m); the initial slope is 0.0015, and the initial grain size of bed material is that reported by the DGWR (2001a). The simulation conditions are shown in Figure 3.38. The calculation length is 30 km. The simulation is performed under the same initial condition as the simulation using the uniform sediment, as shown in Table 3.7.

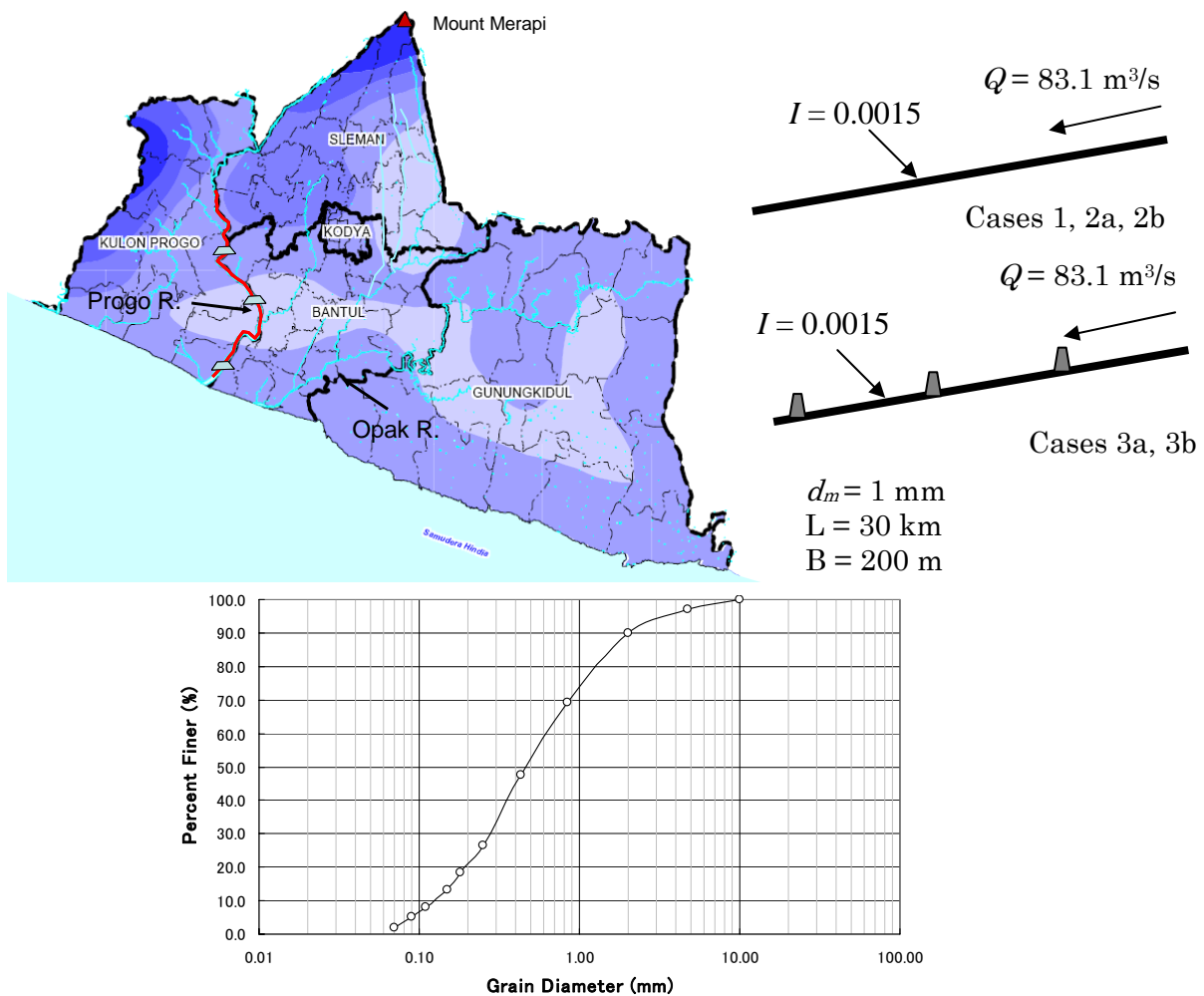

Fig. 3.38 Simulation conditions using non-uniform sediment

(2) Result and discussion

The simulation results using the non-uniform sediment are shown in Figures 3.39 to 3.41. The results under the condition of no management are shown in Figure 3.39 (a). Under these circumstances, riverbed aggradation occurred. At the upper boundary, the aggradation depth reached about 4 m in 10 years. The condition is in a good agreement with the lower Progo River condition before the sabo works is constructed in the slopes of Mount Merapi. Four irrigation intakes and two bridges on the Progo River were affected by debris flows. These structures were rehabilitated so that they function properly (Sumaryono *et al.*, 1996). However, bed aggradation would become severe if the sediment supply is greater than the annual average sediment production such as the condition after a huge eruption in 1930. This indicates that sediment management is required in the upper area to control sediment discharge. Figure 3.39 (b) shows the results for Cases 2a and 2b; degradation of the riverbed occurred in the both cases. Over a 10-year period, the degradation depths at the upper boundary were estimated at 1.5 m and 0.8 m for Cases 2a and 2b, respectively. Figure 3.41 shows the relation between the ratio of sand mining volume to sediment production and the riverbed variation at the upper boundary for Cases 1, 2a, and 2b. Equilibrium is maintained at the upper boundary, if the sand mining volume is about 39% of the sediment production. However, much more sediment is required due to the actual sand consumption. The volume of sand mining in the lower Progo River was estimated to be 1.07 million m³/year, which caused riverbed degradation of 0.178 m/year. Therefore, the riverbed degradation in the lower Progo was estimated to be 0.15–0.328 m/year. The result is similar to that reported by the DGWR (2001a) which estimated bed degradations of 0.10–0.30 m/year in the lower reaches of the Progo River since 1970.

Figure 3.40 shows the results for Cases 3a and 3b. Bed degradation occurs if 100% of the sediment production is consumed by sand mining (Case 3a), even if groundsills are installed. If the sand mining volume is 50% of the sediment production (Case 3b), the riverbed degradation is suppressed by the installed groundsills. The result shows that sand mining activity must be controlled and that

installed groundsills are important for stabilizing the riverbed in the lower Progo River in order to protect or to re-function the existing structures.

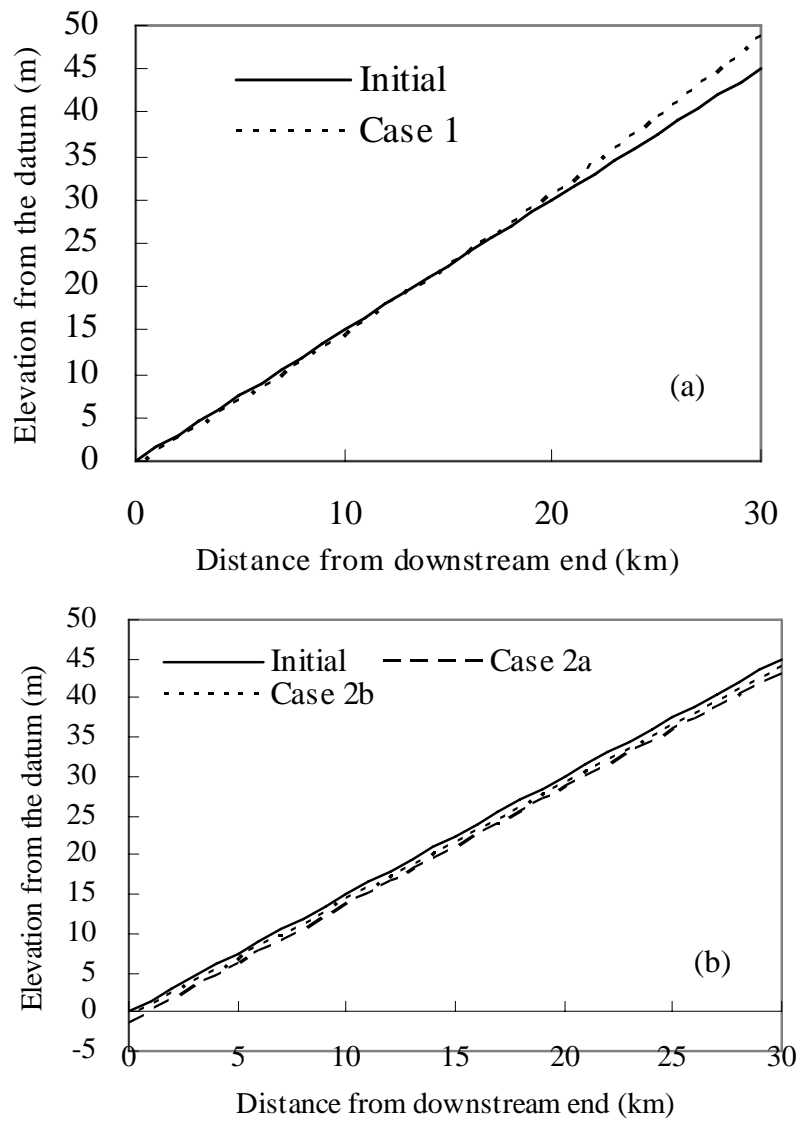

Fig. 3.39 Riverbed variation in Cases 1, 2a and 2b in a period of 10 years using non-uniform sediment

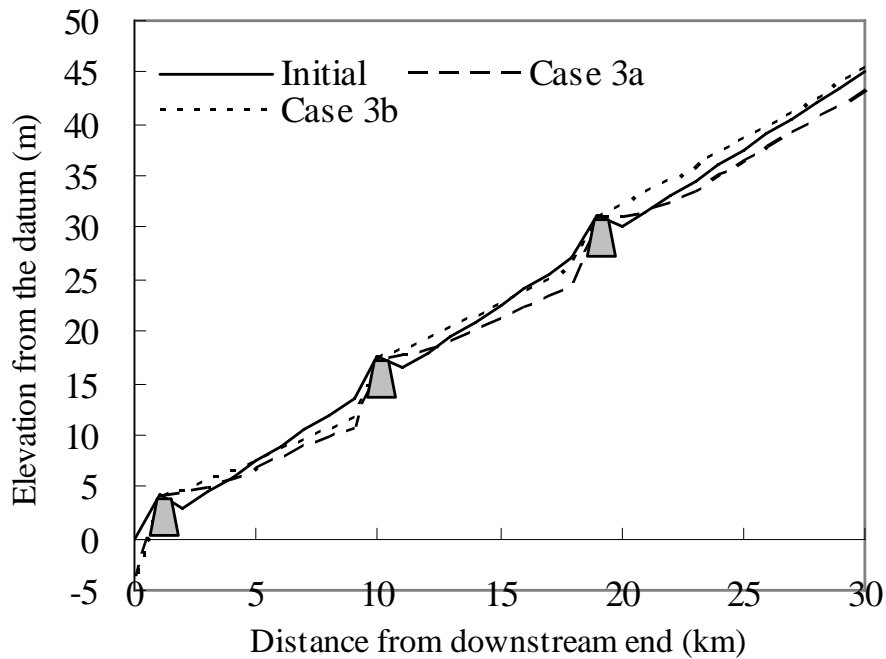

Fig. 3.40 Riverbed variation in Cases 3a and 3b in a period of 10 years using non-uniform sediment

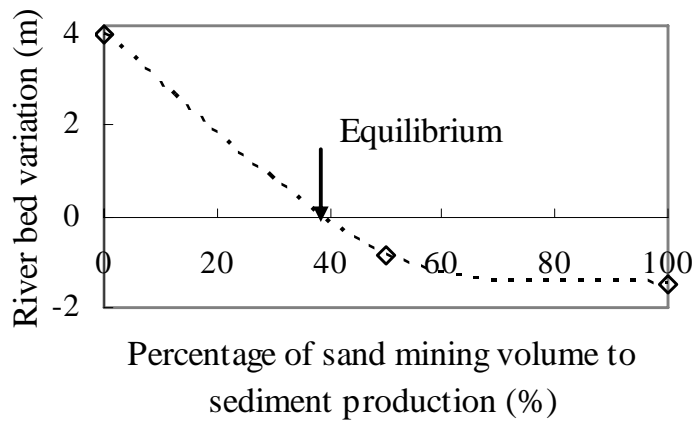

Fig. 3.41 Relationship between sand mining volume and riverbed variation

(3) The Policy on the groundsill installation

The initial condition is similar with the simulation in Sub-section 3.4.2 (3), but in this simulation, the sediment mixture with mean diameter of 1 mm is used. The simulation is carried out 6 conditions, namely from Case 1-n to Case 6-n. The results are presented in Figures 3.42 and 3.44.

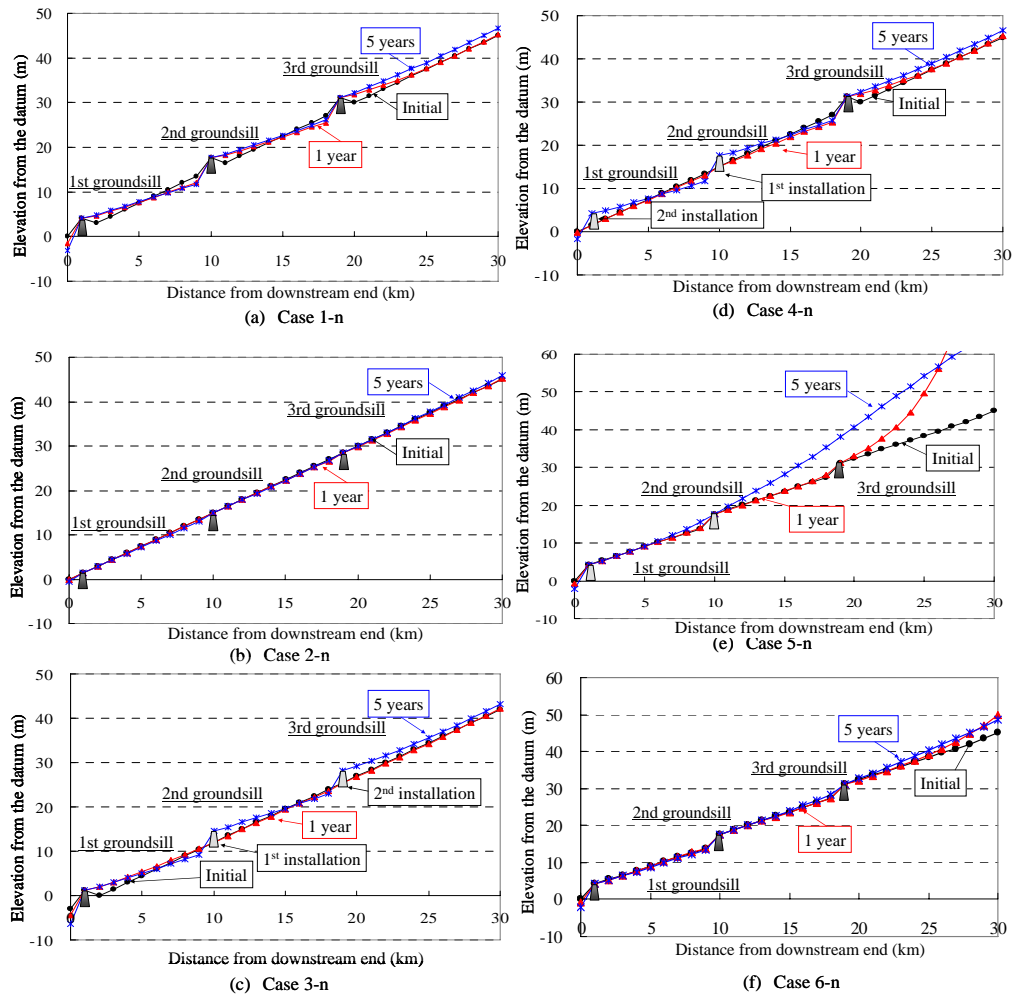

Fig. 3.42 Temporal change of bed geometry using sediment mixture

Figure 3.42 (a) shows the temporal change of bed geometry in Case 1-n. The bed slope between ground sills becomes mild due to the bed deformation. Bed level at 18km from the downstream end decreases until the second year, but it increases in the following years. In fact, occurrence of the bed aggradation at 20km to 30km in 5 years is significant.

Figure 3.43 (a) shows the temporal change of sediment transport between the 2nd ground sill and 3rd ground sill in Case 1-n. The figure indicates that the bed at 18km is degraded until 20 months. The result shows that the local flow condition influences the process of bed geometry until 20 months. Figure 3.44 (a) shows the mean diameter change in Case 1-n. The figure indicates that the bed material at

18km changes coarser until 6 months, and then it becomes finer due to effect of sediment supply from the upstream. The bed material at 30km also becomes coarse until 6 months, and the mean diameter changes from 1 mm to 2 mm. It indicates that the water discharge and the initial slope cannot transport all of grain size of the bed material and the bed is aggradated. On the other hand, the bed material at 20km becomes finer until 6 months and then it become coarse at following months due to effect of sediment supply condition from upstream.

Figure 3.42 (b) shows the temporal change of bed geometry in Case 2-n. The bed degradation between groundsills is not so significant. Under sediment supply is equal to $0.0338\text{m}^3/\text{s}$, the bed level can be kept. Figure. 3.43 (b) shows the temporal change of the sediment transport rate on 3 groundsills in Case 2-n. Sediment transport does not decrease on the 2nd groundsill and the 1st groundsill until 1 year and decrease at following years until the lowest value is reached. Then they increase again due to the sediment supply from upstream. Figure 3.44 (b) shows the mean diameter change in Case 2-n. The figure shows that the bed material at 18km and 20 km are constant until 6 months, and then they become coarser. The bed material at 30km also becomes coarse until 6 months, and then the mean diameter changes from 1 mm to 2 mm. It indicated that sediment supply only can keep the bed material in 6 months at the point and the bed material change to coarser is from upstream to downstream.

Figure 3.42 (c) and (d) show the temporal change of bed geometry in Cases 3-n and 4-n. Comparing among Cases 1-n, 3-n and 4-n, bed degradation at the downstream of groundsills, except for 1st groundsill, is suppressed in Case 3-n. However, after sediment supply flow in downstream of 1st groundsill, depth of the bed degradation can decrease. Hence, the groundsills in Case 3-n are the most stable and the depth of the basement under the bed can be shallow. Figure 3.43 (c) shows the temporal change of the sediment transport rate at the downstream end. From the viewpoint of the impact of groundsills, Case 3-n has the smaller temporal change of sediment discharge. Hence, when groundsills are installed to increase the bed level, it is safe for human being, plants, and animals that the groundsills are installed from downstream to upstream. Figure 3.44 (c) and (d) show the mean diameter change in Case 3-n and 4-n, respectively. In the downstream of the

groundsill, the bed material changes to coarser after 6 months. It indicates that the installed groundsill have impact on the bed material such as armoring in the downstream of groundsill as the finer sediment is trapped in the upstream of groundsill. However, the impact is temporary, and then the mean diameter tends to increase due to armoring process by water flow.

Figure 3.42 (e) shows the temporal change of bed geometry in Case 5-n. Bed elevation at the upstream of 3rd groundsill becomes very high after 1 year and all of the groundsills are filled with sediment after 5 years. Then the slope becomes larger than 0.0015. Hence, the Progo River cannot flow the supplied sediment from upper area under huge eruption. From this point of view, it is necessary to construct such sand pocket at the upper area. Figure 3.44 shows the mean diameter change in Case 5-n. The bed material at 18km and 20km become finer in the first year due to the finer sediment supply from upstream. After sediment supply decreases, the bed material tends to become coarser until the mean diameter estimated at 2 mm. Therefore, the sediment supply rate has impact on bed material change as well as bed level.

Figure 3.42 (f) shows the temporal change of bed geometry in Case 6-n. The bed deformation around the groundsills is very small because of the decrease in the sediment discharge peak during the propagation process to downstream.

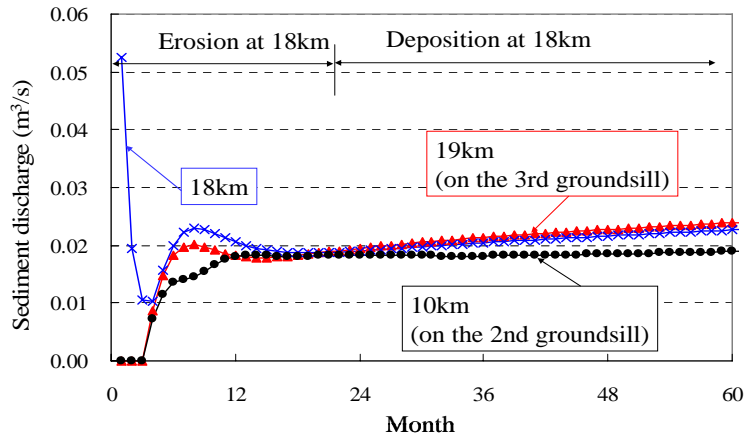

(a) Case 1-n

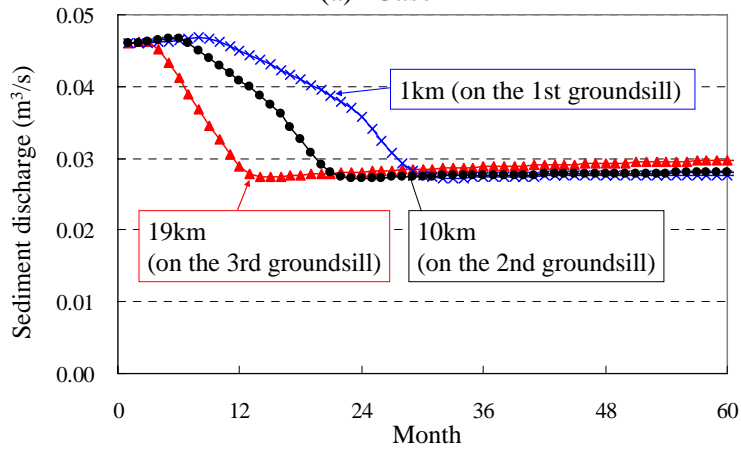

(b) Case 2-n

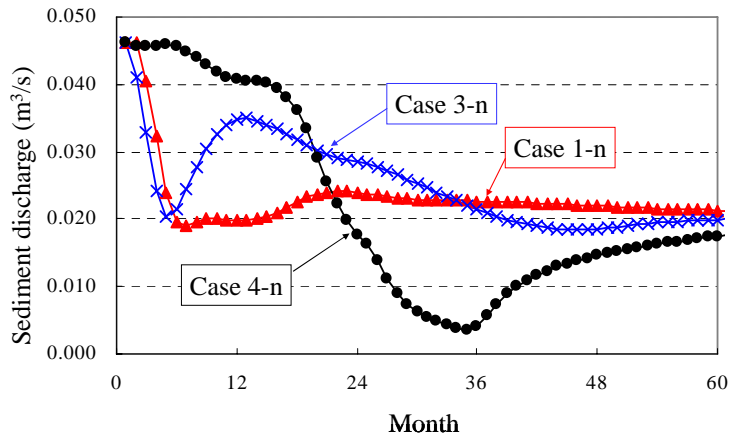

(c) Downstream sediment discharge in Cases 1-n, 3-n and 4-n

Fig. 3.43 Temporal change of sediment transport rate using sediment mixture

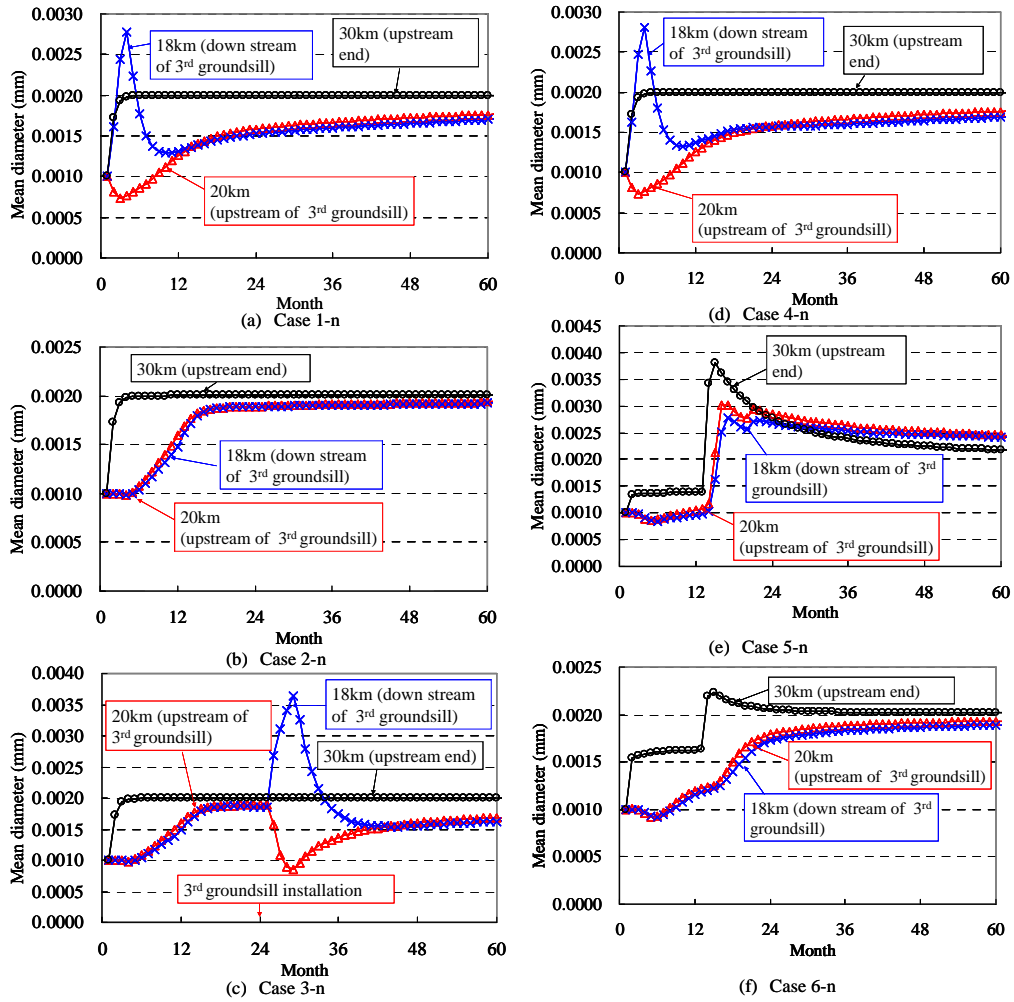

Fig. 3.44 Temporal change of mean diameter with sediment mixture

3.4.4 Effect of variation of sediment production

(1) Hydraulic conditions

In the simulation in sub-section 3.4.2 and 3.4.3, the sediment production is assumed constant that equal to the annual average of sediment production ($1.44 \times 10^6 \text{ m}^3/\text{year}$). However, based on the data that has been recorded by Siswowidjoyo *et al.*, (1995), it shows that the production volume of individual eruptive events ranges from less than 10^6 m^3 to more than $20 \times 10^6 \text{ m}^3$. The effects of the variation of sediment production are necessary to be considered. In this sub-section, the effects of the variation of sediment production on the riverbed in the lower Progo are discussed. The sediment productions in a period from 1930-1959 and 1961-1990 are used as the sediment supply in the upstream boundary end. The sediment production from the volcanic basin area is calculated based on the lava volume of Mount Merapi eruption, and the sediment production from non-volcanic basin area is estimated at about of 20% from the sediment production of volcanic basin. The cumulative of the sediment production from the both area in a period from 1930-1959 and 1961-1990 is shown in Figure 3.45. The hydraulic condition is same as the hydraulic condition used in sub-section 3.4.2. The uniform sediment with the mean diameter of 1 mm is used as the initial bed material. The simulation length is about 46 km, from estuary to Krasak junction, as shown in Figure 3.46.

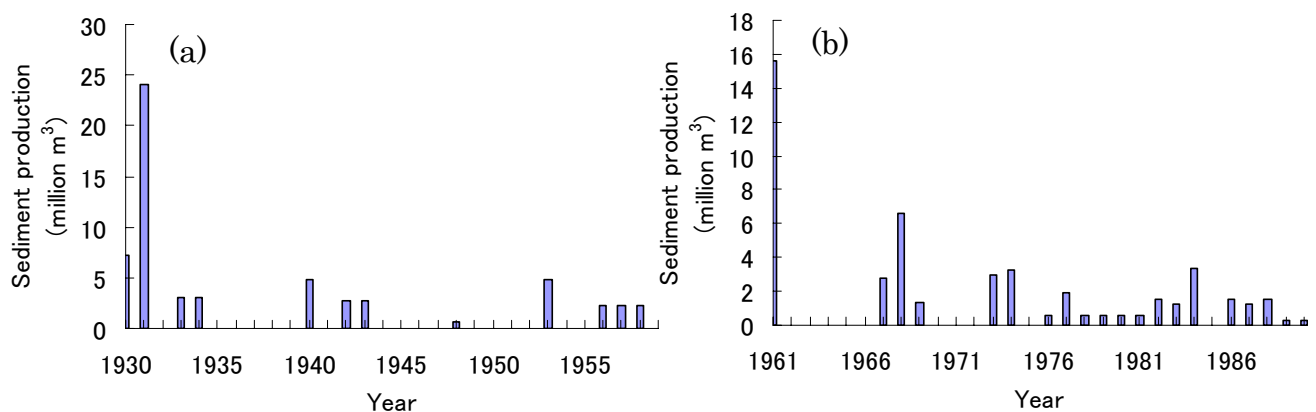

Fig. 3.45 The variation of sediment production in a period from (a) 1930-1959 and (b) 1961-1990

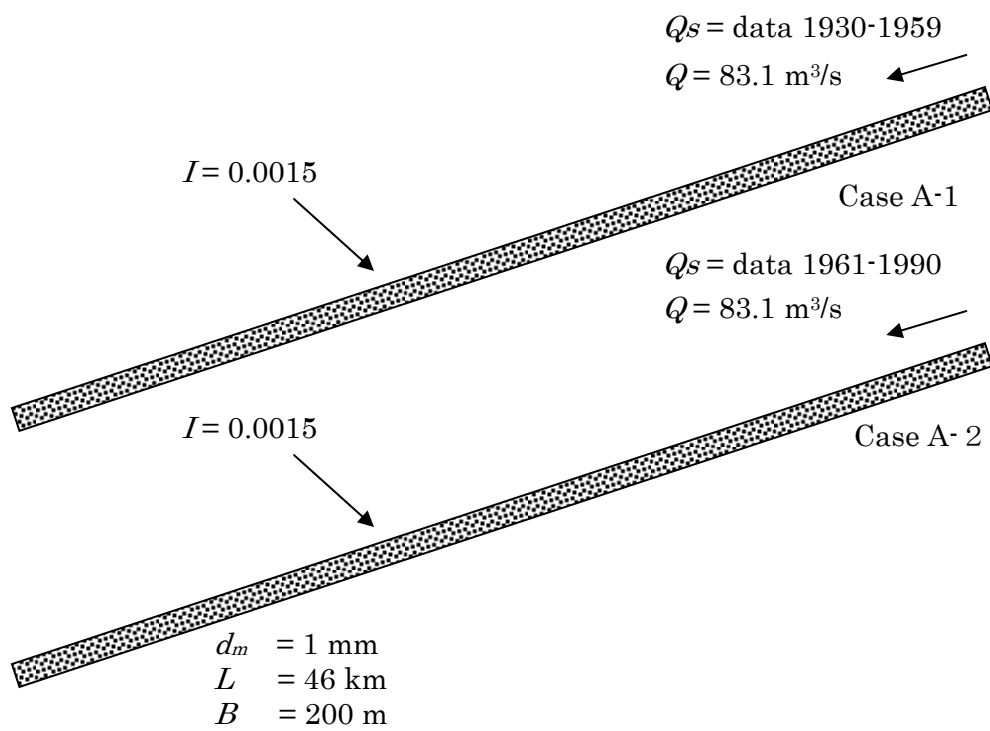
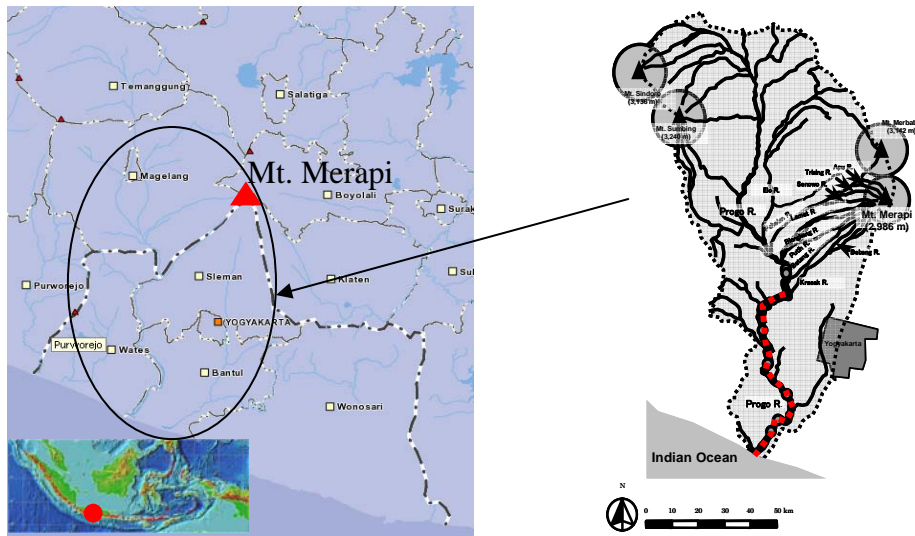

Fig. 3.46 The location of the lower Progo River and the simulation cases

(2) Results and discussion

Figure 3.47 (a) describes the riverbed elevation changes along the lower of the Progo River due to the effect of variation in sediment supply from 1930-1959. After the eruption of 1930 and then followed by the eruption of 1931, the severe aggradation occurred in the upstream boundary end. Then the aggradation will move to the downstream part and the maximum of aggradation depth tends to decline toward the downstream boundary end. This situation will cause the stability of river structures in the upstream area is more dangerous than the other one in the downstream area. If no eruption of Mount Merapi, it means no sediment supply, the riverbed degradation will take place. Figure 3.47 (c) shows the potential aggradation/degradation at the main river structures in the lower of the Progo River in Case A-1. From this figure, it is clear that the aggradation/degradation at the river structures in the upper part is higher than the other one in the lower part. Figure 3.47 (b) shows that the propagation of aggradation/degradation to the downstream part is relatively slow.

Figure 3.48 (a) mentions the simulation results of Case A-2. Immediately after a big eruption in 1961, the severe aggradation in the upstream boundary end occurred. Due to no eruption following the eruption until 5 years, the riverbed tends to be degraded. Then a medium eruption took place, causing the riverbed to increase slightly. Although many eruptions occurred in the end of the period, the riverbed tends to be constant because the eruptions were on a small scale. It means the riverbed is in a stable condition. Figure 3.48 (b) shows that the propagation of aggradation/degradation to the downstream part is slow. Figure 3.48 (c) explains the riverbed variation at the main river structures in the lower Progo River. From this figure, it is indicated that the river structures in the upper part are more unstable than the other ones in the lower part.

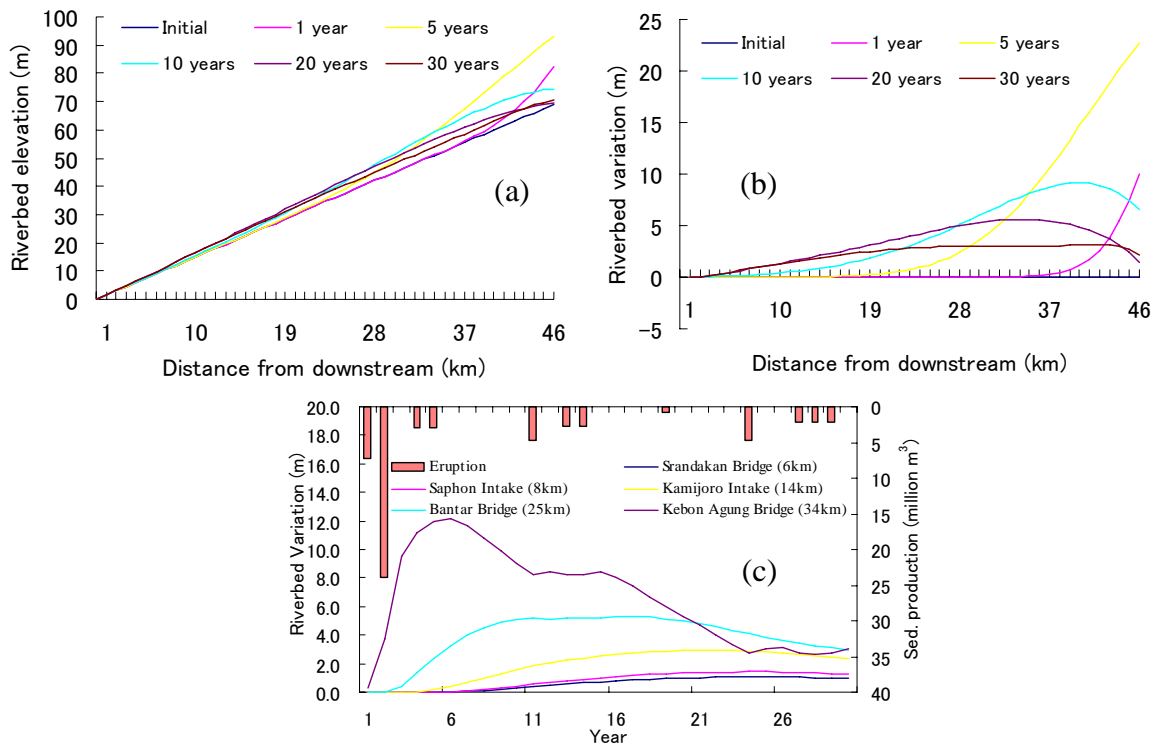

Fig. 3.47 Simulation results of Case A-1, (a) riverbed elevation changes (b) riverbed variation changes and (c) aggradation/degradation in the main structures

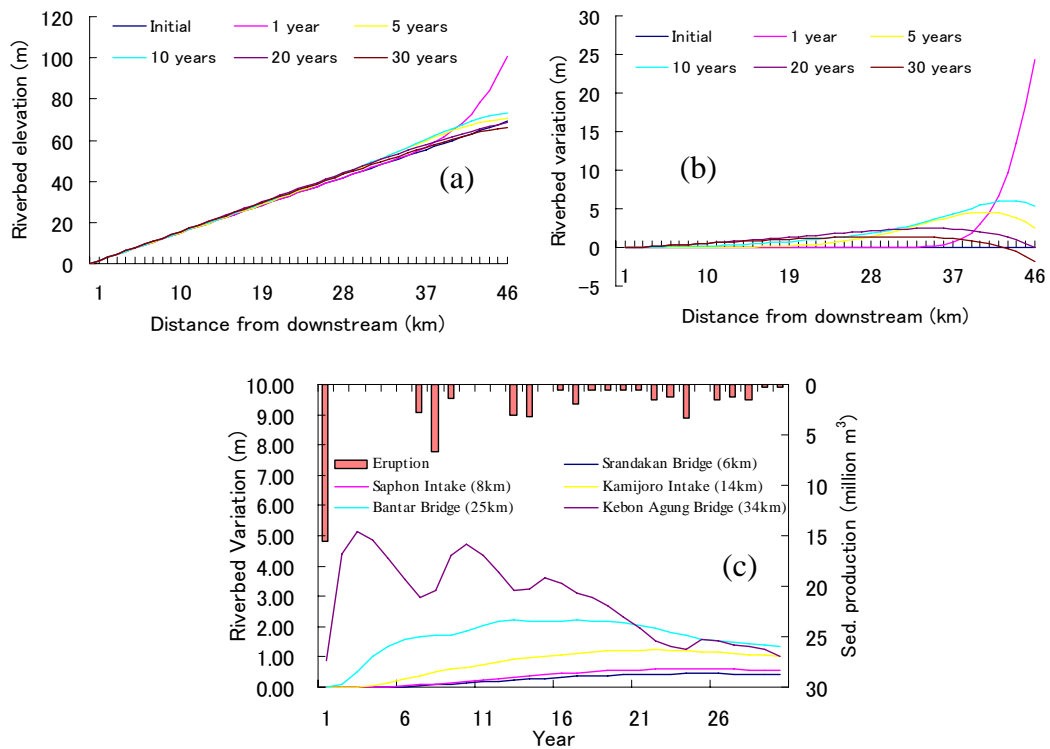

Fig. 3.48 Simulation results of Case A-2, (a) riverbed elevation changes (b) riverbed variation changes and (c) aggradation/degradation in the main structures

From the results of Cases A-1 and A-2, author can conclude as follows:

- The condition of riverbed in the Progo River is very influenced by sediment supply from Mount Merapi.
- A huge eruption of Mount Merapi gives much more the negative impact on the river facilities structures than a series of small eruption. Under huge eruption, the sabo works is necessary to control sediment discharge into the main channel of Progo River.
- The river structures in the upper part are more unstable than the other ones in the lower part due to bed aggradation or bed degradation impacts.

3.5 Sediment Resources Management Combined With Sabo Works

3.5.1 Required volume of sabo works

In sub-section 3.4.4, author still assumed that all of sediment production from an eruption would flow down into the Progo River at the same time when the eruption took place. In fact, the sediment will flow into the Progo River gradually. According to DGWR report (2001b), declining rate of the potential of sediment production caused by an eruption in Mount Merapi follows a trend as described in Table 3.8.

Based on the Table 3.8 and the lava volume data recorded by Siswowardjojo *et al* (1995), the sediment production from 1930 to 1992 could be estimated. Figure 3.49 shows the estimated sediment volume and sediment discharge from Mount Merapi basin during a period from 1930 to 1992.

Table 3.8 Declining rate of potential of sediment volume caused by an eruption

Year after eruption	1	2	3	4	5	6	7
Declining rate	1.00	0.33	0.18	0.12	0.1	0.07	0.06

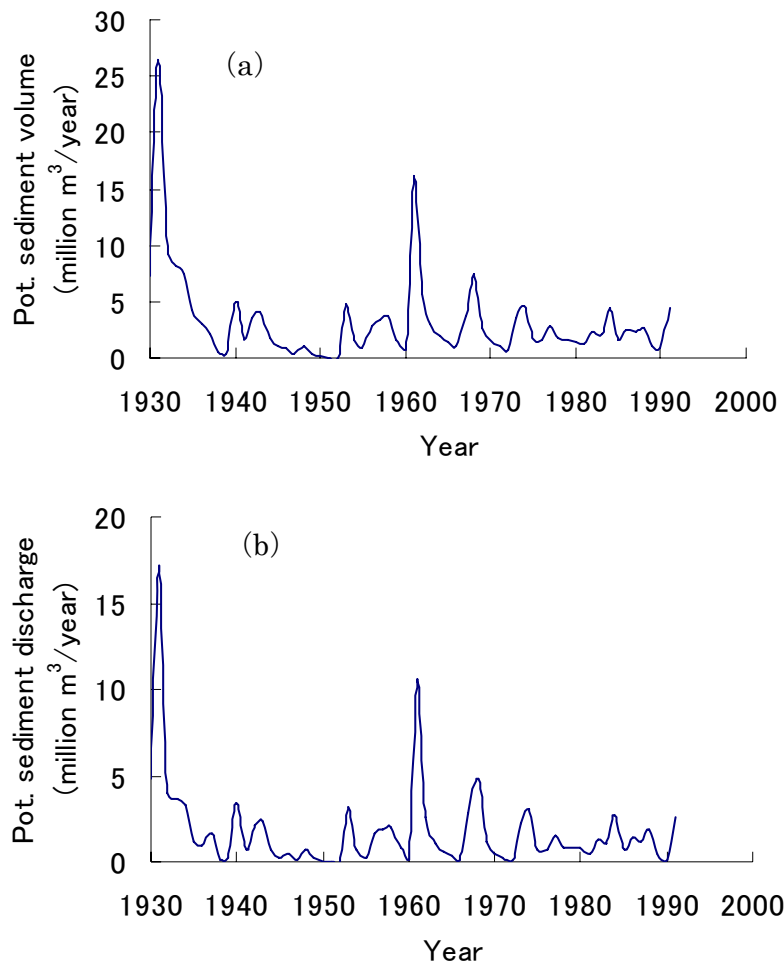

Fig. 3.49 (a) Estimation of potential sediment volume, (b) Estimation of potential sediment discharge from Mount Merapi in period of 1930-1992

From Figure 3.49, we can see that the potential sediment volume provided by Mount Merapi depends on the scale of its eruptions. Sometimes, the potential sediment volume is very huge or very small. A huge eruption, such as eruption of 1930-31, has a significant impact on the main river (Progo River) for many years. The trend of potential sediment discharge (Q_{sp}) is the same as the potential sediment volume. To manage sediment discharge from Mount Merapi, so that it does not produce sediment disaster in the downstream area, a method using combination of sand mining management and sabo works would be discussed. The sand mining volume, Q_{Sm} , is set up at, 5 million m^3 /year, 1.44 million m^3 /year, 0.72

million m³/year and no sand mining. Based on the result shown in Figure 3.49 (b), the excess of sediment discharge, Q_{se} , could be calculated using equation 3.20. The calculation result of the excess of sediment discharge is shown in Figure 3.50.

$$Q_{se} = Q_{sp} - Q_{sm} \quad (3.20)$$

When $Q_{se} < 0$, the value of Q_{se} assumed is equal to zero. The sand mining activity can be used as a tool to control the sediment discharge into the Progo River. If sand mining volume is the same as present condition that is estimated at 5 million m³/year, the activity causes no sediment supply flowing down in most time, so that the severe riverbed degradation would be occurred in the Progo River. To overcome the riverbed degradation, we can use channel works, such as groundsills. However, as no sediment is supplied from the upstream area, finally the groundsills would collapse. Hence, the sand mining volume in the Mount Merapi basin has to be controlled. If sand mining volume is 1.44 million m³/year, the effect of sand mining in the downstream area is better than present condition. The sediment discharge can flow to the main river trough its tributaries. However, sediment is not supplied into the main river during most of time. The most reasonable sand mining volume is about 0.72 million m³/year. Under this condition, a part of sediment produced by Mount Merapi can enter to the Progo River for keeping the riverbed, although this situation does not continue for a long time. To anticipate no sediment supply from upstream area, a groundsill installation can be used. If no sand mining, it is the best way to protect the riverbed from degradation.

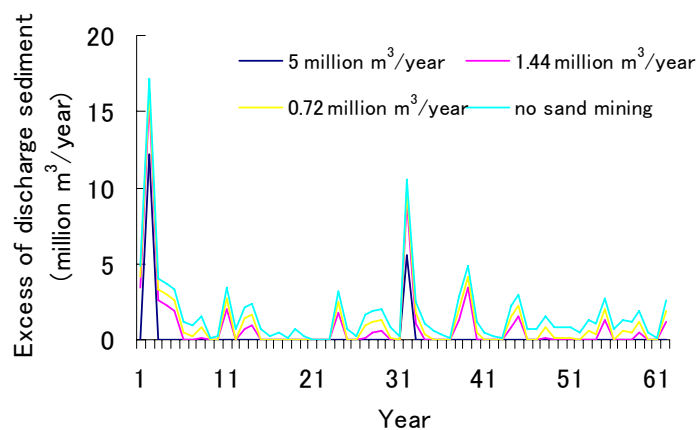

Fig. 3.50 The excess of sediment discharge from Mount Merapi

However, the choice is difficult to be applied in Mount Merapi due to the socio-economical reason. From Figure 3.50, we also understand that sometimes the Mount Merapi produces huge sediment production. To overcome this situation, the sabo works are effective. The volume, V_{sw} , to be controlled by sabo works can be calculated on the basis of the excess sediment discharge and the allowable sediment discharge (Q_a) (equation 3.21). From the sub section 3.4.2, the allowable sediment discharge is equal to sediment discharge to the sea, which is estimated at 1.46 million $m^3/year$. Figure 3.51 shows the sediment discharge from Mount Merapi basin that must be captured by sabo works. The result indicates that sabo works are strongly required for huge eruptions as eruption in 1930-1931 and 1961.

$$V_{sw} = Q_{se} - Q_a \quad (3.21)$$

In order to prevent sediment disaster in this area, it is necessary to provide an available volume of check dams. The required volume of check dams is shown in Figure 3.52. This figure describes that if there is no sand mining, the required volume of check dams is biggest. Of course, the investment to construct the check dams is also most expensive. If the sand mining volume increases, the required volume of check dams will decrease. The required volume of check dams is minimum when the sand mining volume is equal to present condition.

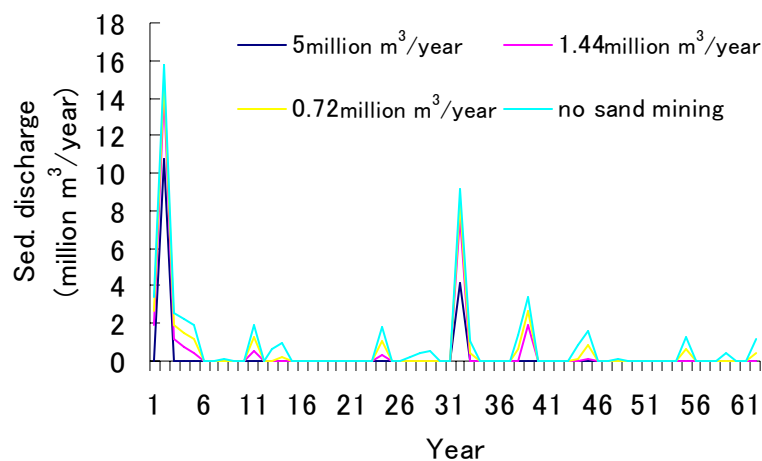

Fig. 3.51 The sediment discharge from Mount Merapi that must be captured by sabo works

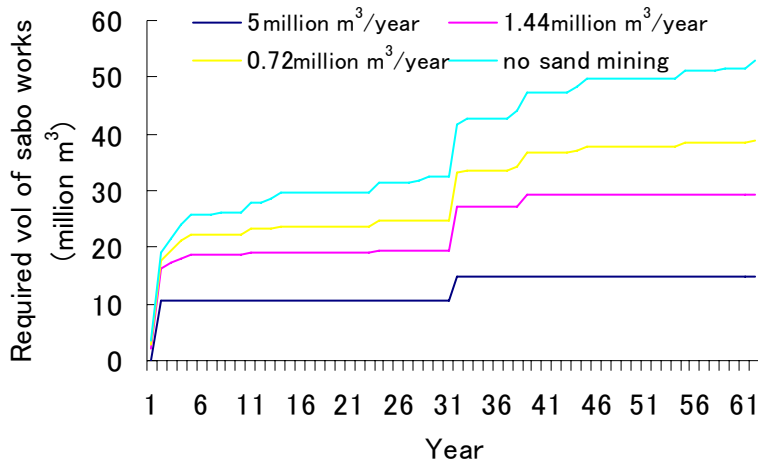

Fig. 3.52 Cumulative of required volume of sabo works

Controlled sand mining is the most the reasonable management in the Mount Merapi. Hence, the combination among sand mining management, sabo works, and channel works is necessary to be applied in Mount Merapi basin.

3.5.2 Effects of sabo works

In order to evaluate the effects of sabo works on reduction of sediment discharge from Mount Merapi, one dimensional bed variation analysis was used. The simulations with sabo works as well as without sabo works are carried out. The simulation is performed from a tributary of Progo River, namely Putih River, to the lower reach of Progo River. Figure 3.53 shows the location of lower Progo River and Putih River.

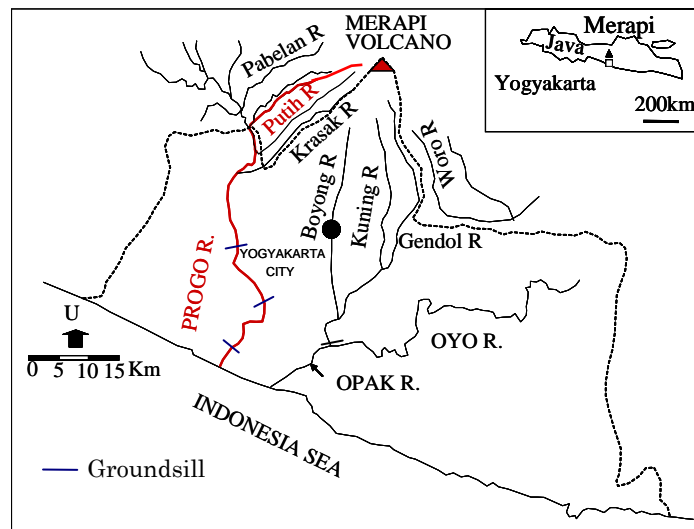

Fig. 3.53 The location of Putih River and lower Progo River. The length of simulation is indicated by the red colour line.

(1) Without sabo works

Various simulations under without sabo works are shown in Table 3.9. The initial data of the Putih River is as follows. The initial bed slope is 0.0301, channel width is 41 m, and the simulation length is 24 km. Condition of the Putih River is under natural condition or no installed sabo works. The water supply rate into the Putih River is constant of 9.186 m³/s, which is the annual averaged water discharge in the Putih River. The boundary condition for the Progo River is described as follows. The simulation length is 56 km from the river mouth to the confluence with the Putih River, the channel width is 200 m, the initial bed slope is 0.0015. The annual water discharge of 83.1 m³/s is supplied at the upper boundary end of Progo River. Three groundsills with height of 2.7 m are installed in the lower Progo River, and the distance between groundsills is 9 km. Sediment mixture with mean diameter of 30 mm is used in the Putih River and sediment mixture with mean diameter of 1 mm is used in the Progo River. The simulation is carried out under 3 conditions, namely no sand mining (B-1), with sand mining in which mined volume is half of annual sediment production from Mount Merapi (B-2) and with sand mining in which mined volume is equal to annual sediment production from Mount Merapi (B-3). Sand mining is assumed to be undirected in upper Putih River. Sediment supply conditions for Cases B-1, B-2 and B-3 are 1.2, 0.6 and 0.0 million m³/year. The simulation conditions are summarized in Table 3.9. Figure 3.54 shows the simulation conditions without sabo works.

Table 3.9 Simulation conditions in the cases of without sabo works

Case	Putih River						Progo River					
	Sand mining (10 ⁶ m ³ /year)	Sed. supply (10 ⁶ m ³ /year)	d_{mean} (mm)	I	B (m)	Q (m ³ /s)	Groundsill	d_{mean} (mm)	I	B (m)	Q (m ³ /s)	
							No.	H (m)				
B-1	0	1.2	30	0.0301	41	9.186	3	2.7	1	0.0015	200	83.1
B-2	0.6	0.6	30	0.0301	41	9.186	3	2.7	1	0.0015	200	83.1
B-3	1.2	0	30	0.0301	41	9.816	3	2.7	1	0.0015	200	83.1

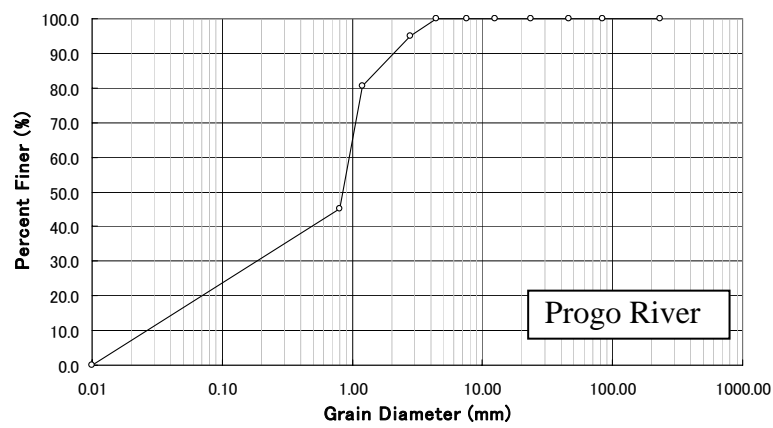
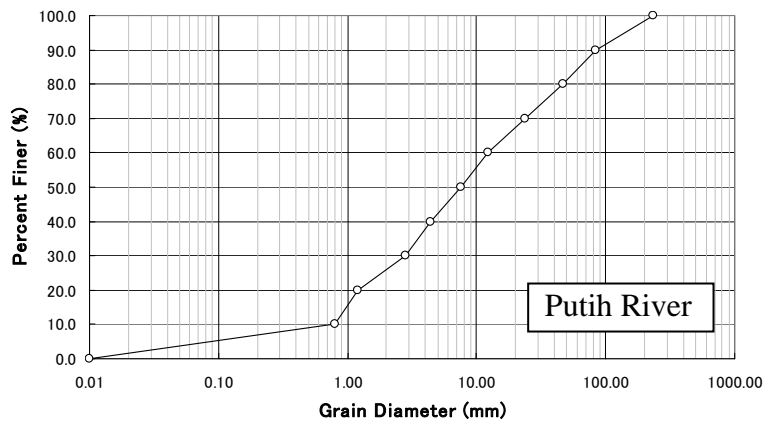
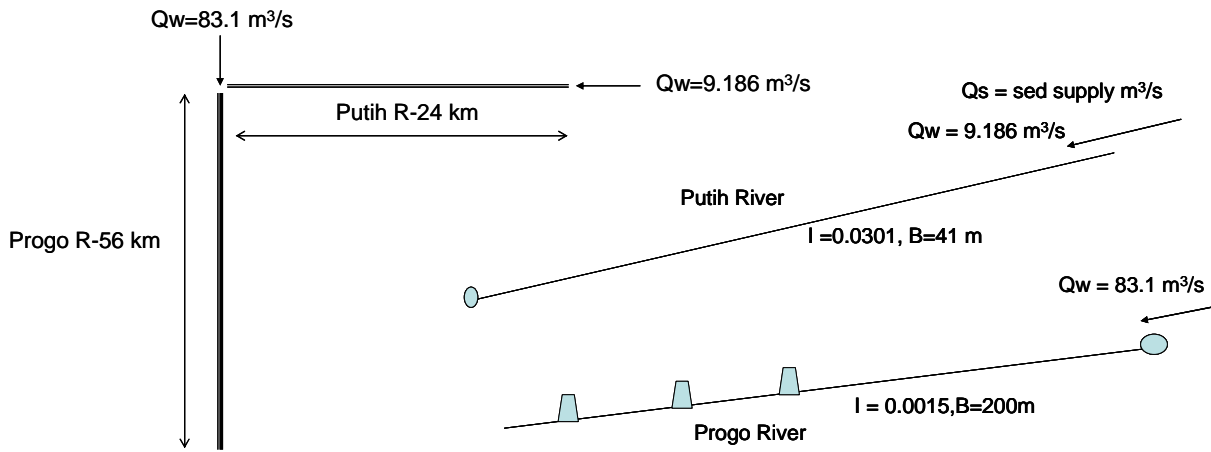

Fig. 3.54 Simulation conditions for cases without sabo works

(2) Simulation results with sabo works

The simulation results on bed and sediment discharge changes for those cases are shown in Figures 3.55, 3.58 and 3.59, respectively. Each figure shows the deposition depth and the temporal sediment discharge changes.

Figure 3.55 shows that sediment discharges at 10 km and 2km points upstream of downstream end of Putih River increase in the first year and then tend to be constant in the following year. After the first year, sediment discharges at the upstream point (24 km), the midstream point (10 km) and the downstream point (2 km) are the same. This result indicates that all of supplied sediment from the upstream boundary of the Putih River is transported to the Progo River. In the Progo River, the sediment from the Putih River is supplied into the lower reach of Progo River. However, the sediment discharge in the lower reach of Progo River is not influenced by sediment production from Mount Merapi. The result indicates that the sediment propagation to the lower reach of the Progo River is low by the annual average water discharge. In fact, the water discharge of the Progo River is not constant. In a large discharge, sediment production from Mount Merapi can be transported fast to the lower reach of the Progo River and then it will be deposited in this part.

Figure 3.56 shows the simulation results on sediment discharge and bed change with variation of sediment supply. The figure indicates that severe bed aggradation takes place in the upstream end of Putih River due to a huge eruption in the first year. Then the deposition depth is relatively constant after the fifth year because the sediment supply is equal to the sediment discharge to the downstream part. Figure 3.56 shows that all of the sediment supply is also transported to the downstream area, if the average annual sediment supply is used as the boundary condition in the upstream end of Putih River. However, if the variation of sediment supply is used as the boundary condition, all of the sediment will not be transported due to the insufficiency of water discharge. As a result, when huge eruption occurs, severe aggradation would take place.

Figure 3.57 shows simulation results on sediment discharge and bed change with temporal variation of sediment supply and sand mining. Here, the volume of sand mining is about 40% of annual sediment production from Mount Merapi. The

figure describes that sand mining can reduce sediment discharge to the downstream area. The result indicates that sand mining can be used as a tool for controlling sediment discharge in order to secure assets and people live in downstream area.

Figure 3.58 shows simulation results on sediment discharge and bed change in Case B-2. Similar to the result in Figure 3.57, Figure 3.58 also indicates that sand mining activities in the upstream can reduce the sediment discharge flowing down into the downstream part. Based on this result, the sand mining can be used as an alternative tool to control sediment discharge in Mount Merapi basin. When the sediment is produced from Mount Merapi under a huge condition, the sand mining is necessary to remove the sediment deposits. However, if sand mining is so excessive and no sediment is supplied into the Progo River, slight degradation takes place in the Putih River, as shown in Figure 3.59. Based on the results explained above, sand mining control is necessary to be applied in Mount Merapi basin, especially after a huge eruption took place. However, it needs a pay attention if sand mining would become a method of sediment management. Figures 3.55, 3.58 and 3.59 illustrate that degradation would take place in Progo River because the sediment supply from Mount Merapi to Progo River is lower than the equilibrium sediment discharge to sea.

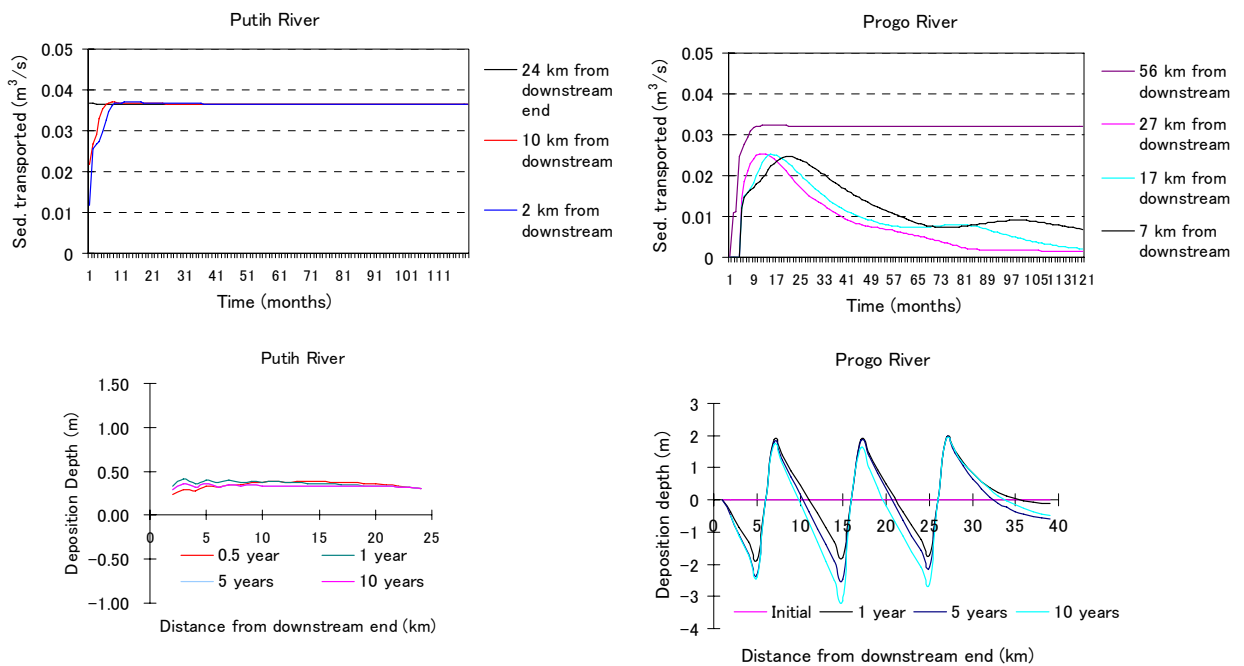

Fig. 3.55 Simulation result on sediment discharge and bed change in Case B-1 (without sabo works and no sand mining)

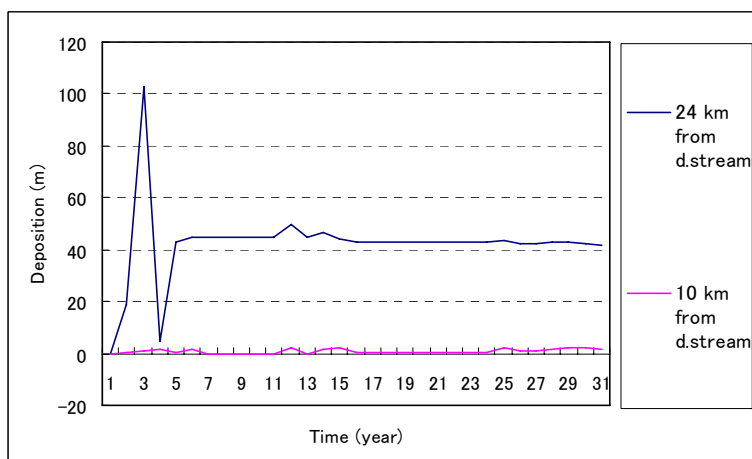
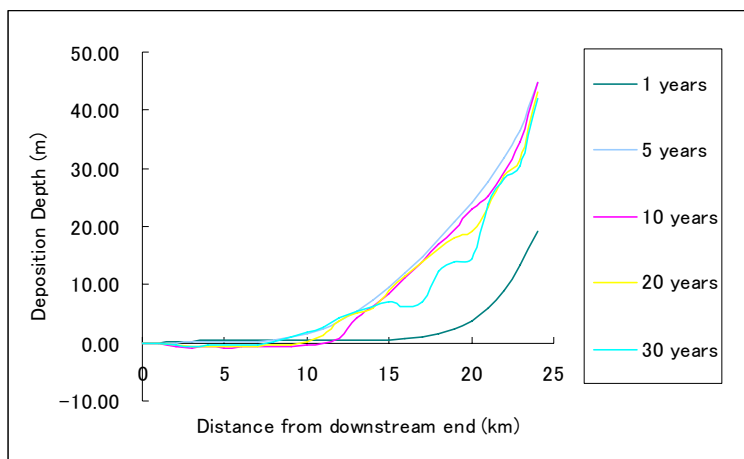
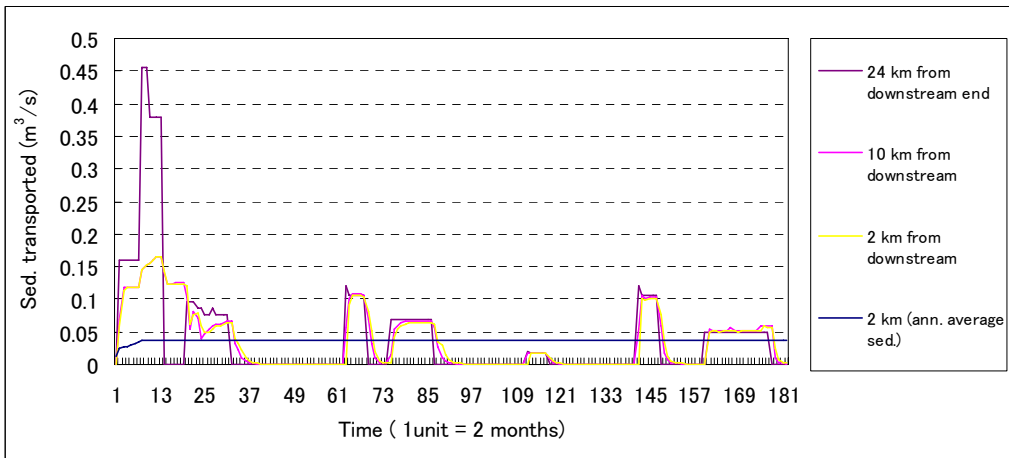

Fig. 3.56 Simulation result on sediment discharge and bed change with variation of sediment supply (without sabo works and no sand mining)

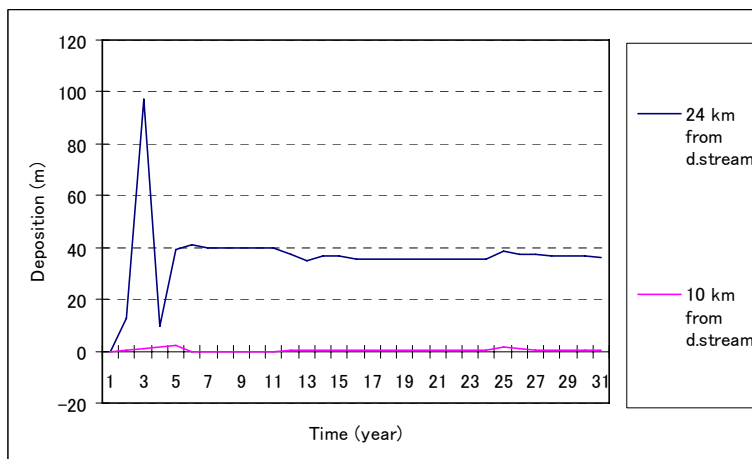
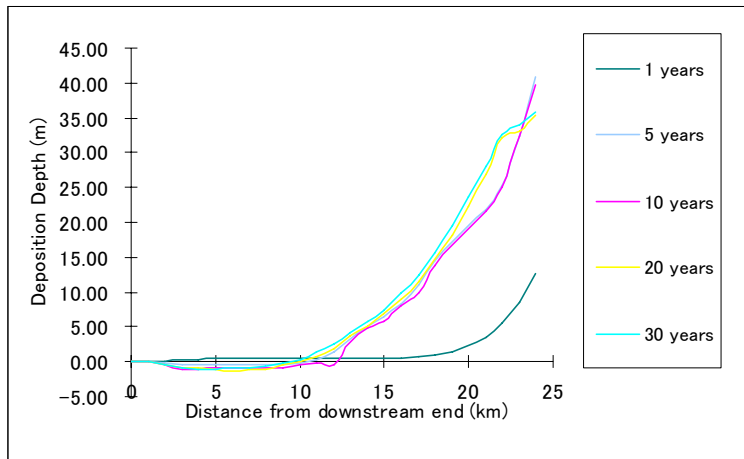
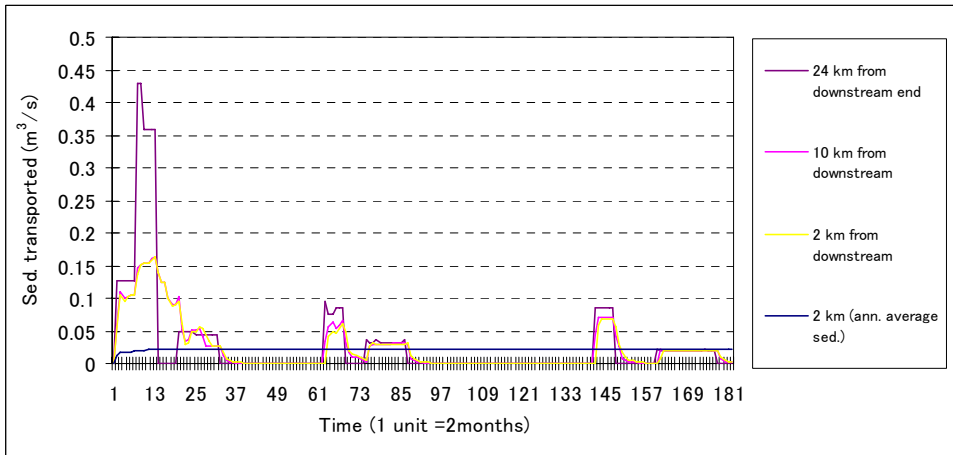

Fig. 3.57 Simulation result on sediment discharge and bed change with variation of sediment supply (without sabo works and sand mining (40%))

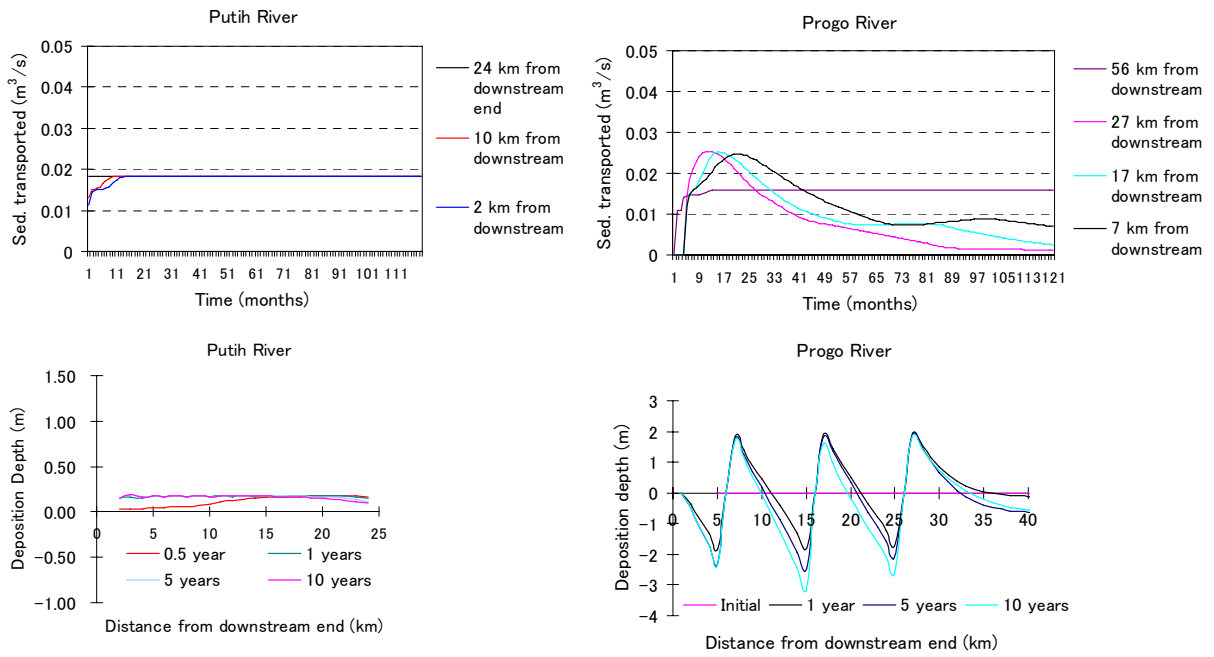

Fig. 3.58 Simulation result on sediment discharge and bed change in Case B-2 (without sabo works and sand mining volume of 50% annual sediment production)

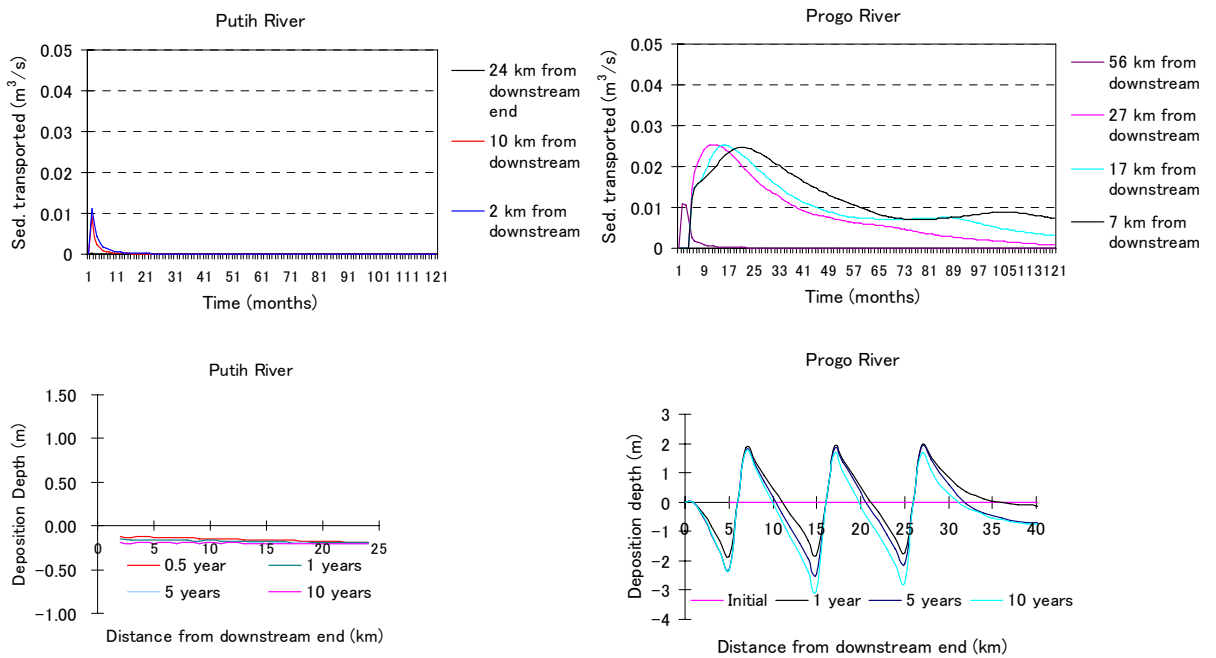

Fig. 3.59 Simulation result on sediment discharge and bed change in Case B-3 (without sabo works and sand mining volume of 100% annual sediment production)

(3) With sabo works

To investigate the effect of sabo works, two sabo dams with the height of 5 m are installed at 10 km and 20 km upstream from downstream end of the Putih River. The data and characteristic geometry are the same as the data used in simulation without sabo works. The simulations are carried out under 3 cases, i.e. no sand mining (Case C-1), sand mining volume of 50% annual sediment production (Case C-2) and sand mining volume of 100% annual sediment production (Case C-3). The simulation conditions with sabo works are summarized in Table 3.10 and shown in Figure 3.59. Figure 3.58 shows the grain size distribution used in the simulation.

Table 3.10 Simulation conditions in the case of with sabo works

Case	The Putih River						The Progo River					
	Sabo work	Sand mining (10 ⁶ m ³ /year)	Sediment supply (10 ⁶ m ³ /year)	<i>I</i>	<i>B</i> (m)	<i>Q</i> (m ³ /s)	Ground sill	<i>I</i>	<i>B</i> (m)	<i>Q</i> (m ³ /s)		
	No	H (m)					No.	H (m)				
C-1	2	5	0	1.2	0.0301	41	9.186	3	2.7	0.0015	200	83.1
C-2	2	5	0.6	0.6	0.0301	41	9.186	3	2.7	0.0015	200	83.1
C-3	2	5	1.2	0	0.0301	41	9.816	3	2.7	0.0015	200	83.1

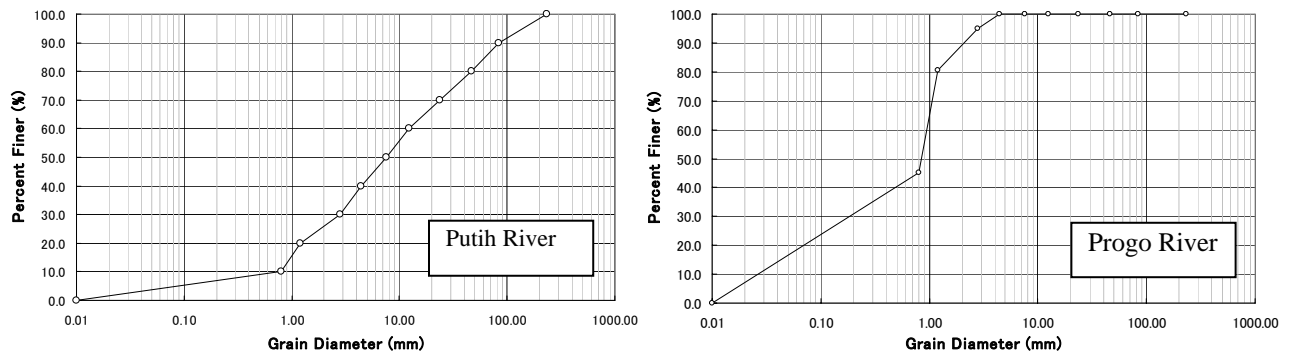

Fig. 3.60 Grain size distribution for Putih and Progo Rivers

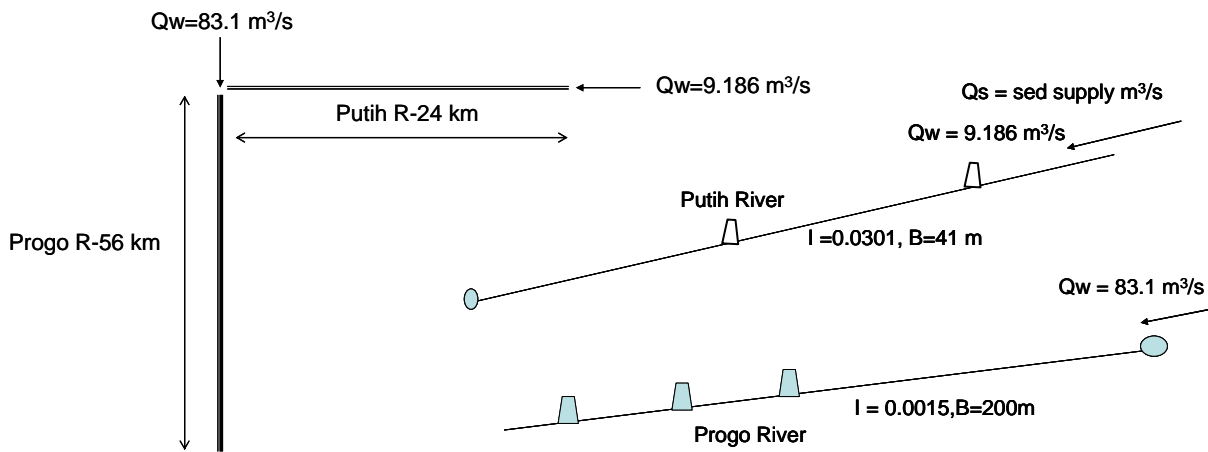
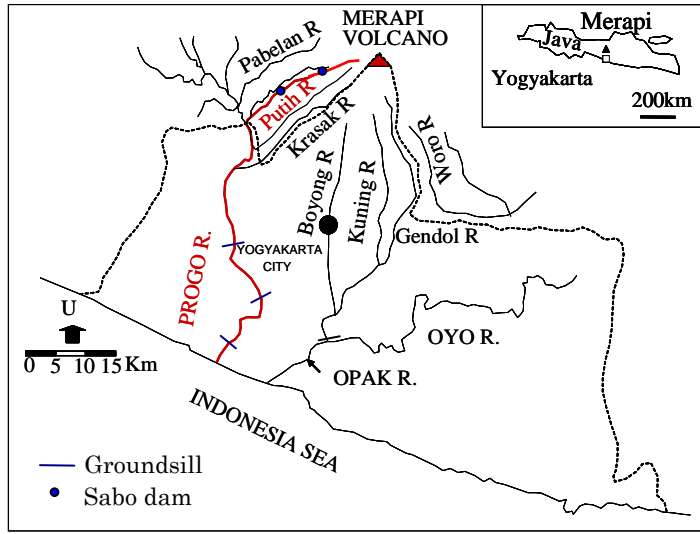

Fig. 3.61 Simulation conditions for cases with sabo works

(4) Simulation results with sabo works

The simulation results for Cases C-1, C-2 and C-3 are shown in Figures 3.62, 3.63 and 3.64, respectively. Figure 3.62 shows that aggradation occurred in the Putih River during the first year due to sediment supply from Mount Merapi. Depths of deposited sediment in the upstream part of the sabo dams are deeper than those in the other locations. It indicates that the sabo dams could capture supplied sediment. However, because the sediment supply from upstream boundary

is larger than volume of the sabo dams, the effect of the sabo dams to reduce sediment discharge is not significant. Figure 3.63 shows that sand mining can reduce the deposition depth in the upstream of the sabo dams, so that the function of sabo dams can be long as a tool for sediment disaster prevention. Figure 3.64 shows that the degradation takes place in the most of the Putih River due to no sediment supply, except at the upstream of the sabo dams. It indicates that the sabo dams can be used as a disaster prevention and riverbed stabilization.

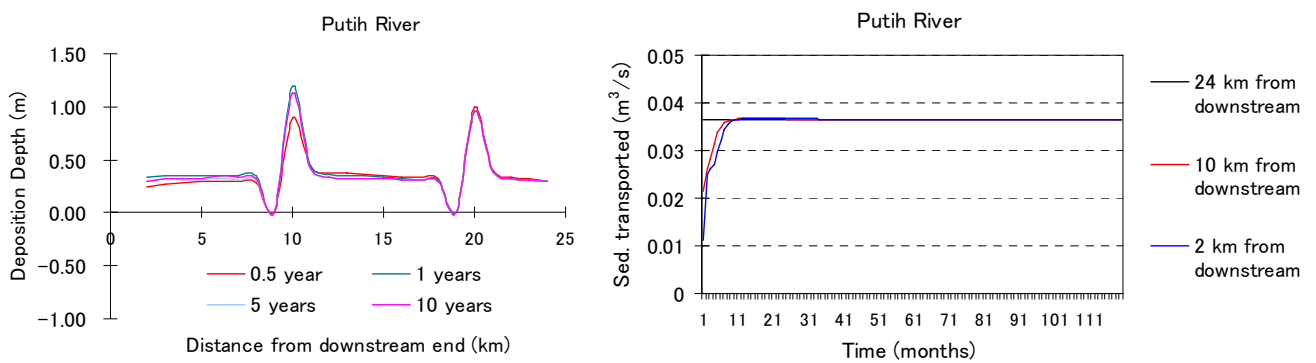

Fig. 3.62 Simulation result on sediment discharge and bed change in the Putih River in Case C-1 (with sabo works and no sand mining)

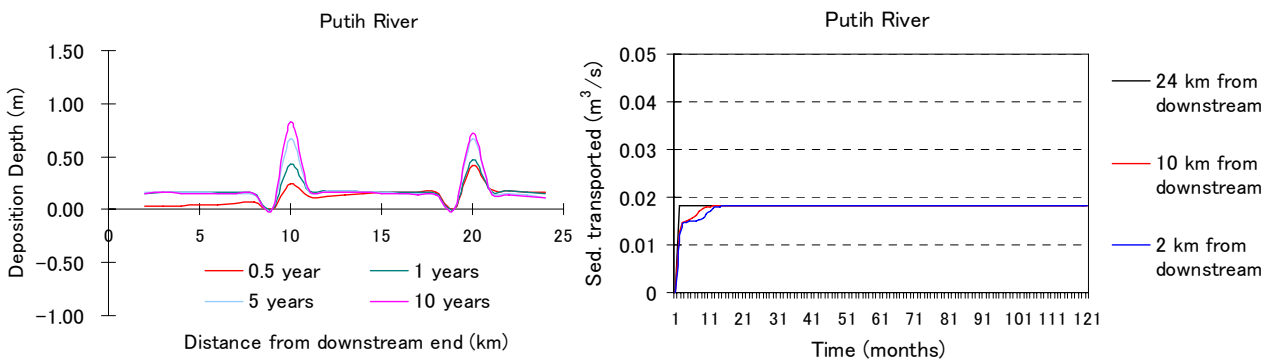

Fig. 3.63 Simulation result on sediment discharge and bed change in the Putih River in Case C-2 (with sabo works and sand mining volume of 50% annual sediment production)

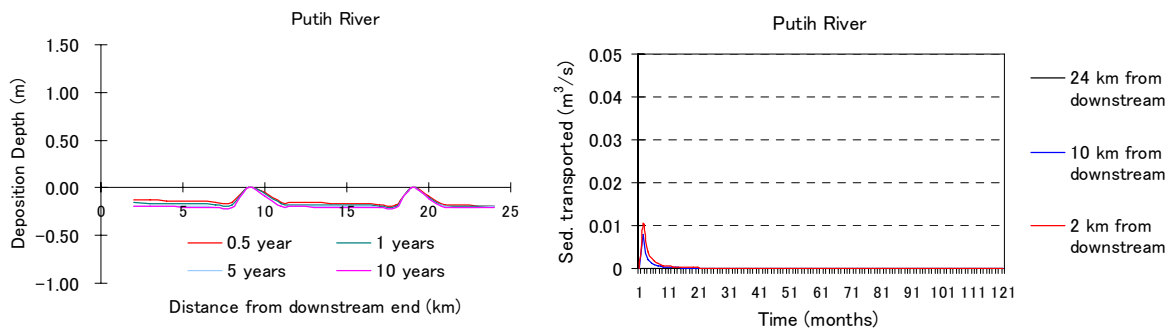
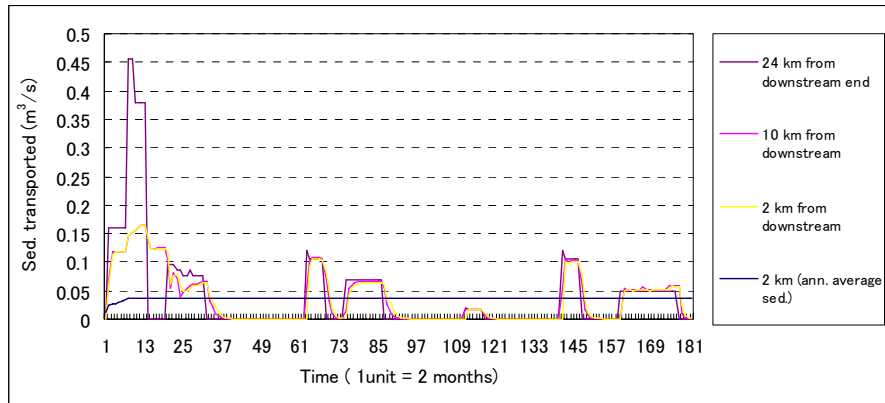

Fig. 3.64 Simulation result on sediment discharge and bed change in the Putih River in Case C-3 (with sabo works and sand mining volume of 100% annual sediment production)

Figure 3.65 show the temporal change of sediment discharge in Putih River without and with sabo dams due to variation of sediment supply. Figure 3.65 (a) indicates that when huge eruption takes place, all of the sediment cannot be transported by the water discharge. However, the water discharge can transport all of the sediment caused by an ordinal eruption. Sabo dams can reduce the sediment discharge to downstream part as shown in Figure 3.65 (b). In a huge eruption or an ordinal eruption case, the sabo dams can give more safe condition in the basin. Figure 3.66 shows the temporal change of the sediment discharge in Putih River without and with sabo dams combined with sand mining. Figure 3.66 (a) shows that sand mining can be used as an alternative method to decline sediment discharge to downstream part. From Figure 3.65 (b), we also understand that sabo dams are one of methods to manage sediment discharge. Combination between sabo dams and sand mining control is also one of methods on sediment mitigation in Mount Merapi basin. Figure 3.66 (b) shows that sabo dams combined with sand mining control can reduce sediment discharge significantly. Figure 3.67 shows temporal change of the deposition in Putih River under installed sabo dams case combined with (a) no sand mining, (b) sand mining volume of 40% annual sediment production. The figure describes that sand mining

can reduce the deposition depth. It indicates that sabo dams combined with sand mining control are reasonable to be applied in Mount Merapi basin.



(a) Without sabo dams

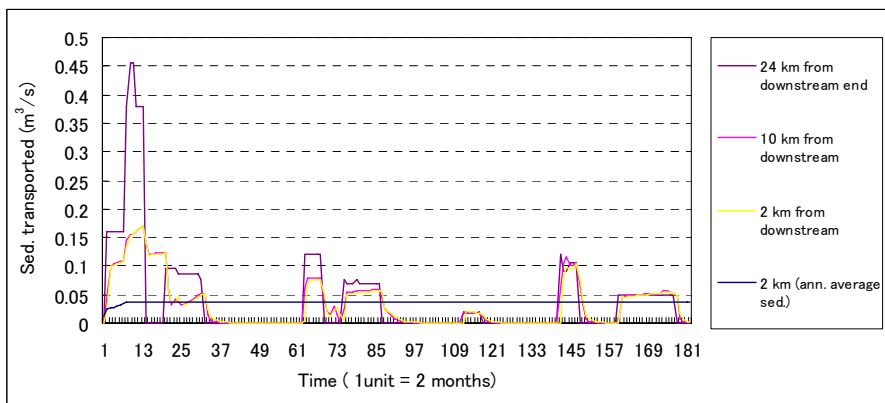

(b) With sabo dams

Fig. 3.65 Temporal sediment discharge due to variation of sediment supply in Putih River with no sand mining

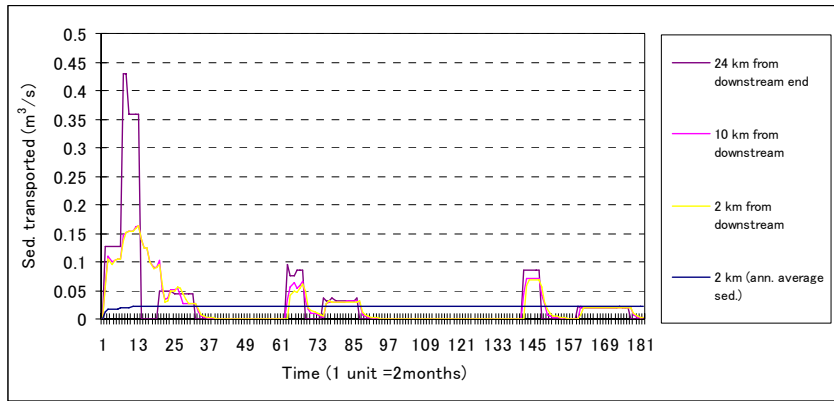

Without sabo dams

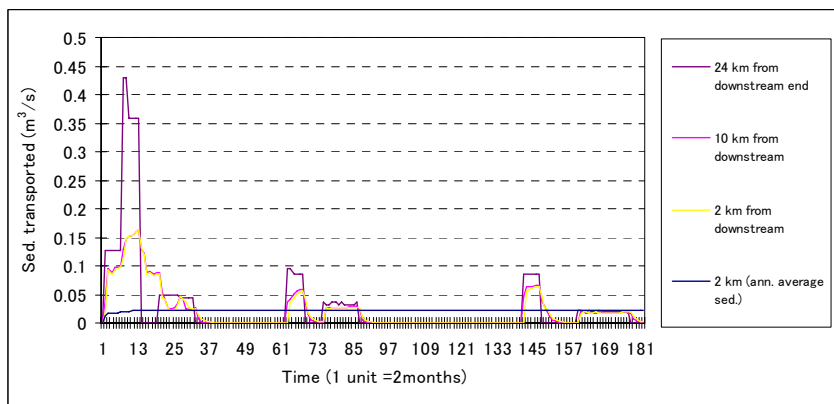

With sabo dams

Fig. 3.66 Temporal sediment discharge due to variation of sediment supply in Putih River with sand mining volume of 40% annual sediment production

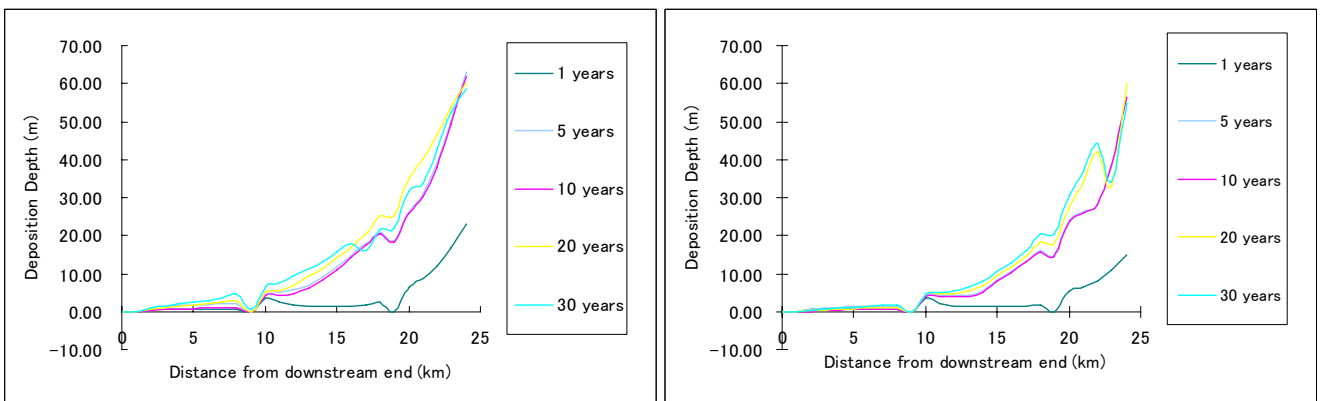

Fig. 3.67 Temporal deposition in Putih River under installed sabo dams case combined with (a) no sand mining, (b) sand mining volume of 40% annual sediment production

3.6 Summary

Mount Merapi eruptions have produced large amounts of volcanic material as ash falls, lava and pyroclastic flows. Produced sediment deposited on the slopes of Mount Merapi and threatens local residents. Due to the increase in consumption of sand, the sand mining has extended rapidly involving mining companies with heavy equipments. The sand mining activity has increased significantly since 1999; when the regional governments have been given and broaden autonomy. The sediment resources management has given benefits for people through sand mining activity, but they have neglected the concept of sediment sustainability and environment conservation in the management.

The main problem in sustainable sand mining management is how to determine the allowable sand mining volume. A procedure to determine the allowable sand mining volume was presented. A designed bed slope, calculating the sediment discharge to the sea, and the allowable sand mining volume are determined step by step based on the designed sediment supply rate.

To consider two aspects of sediment, namely resources and disasters, a framework of sediment management method has developed using a one dimensional bed deformation analysis. By considering the current conditions in the downstream area, the proposed sediment management has recommended to install a series of channel works in the study areas. It was described that the the combination among disaster mitigation, controlling sand mining and riverbed stabilization is strongly necessary to be implemented.

References

- Amri, P.D., (2000), *Economic and politic influences of law number 22/1999 and 25/1999 about autonomy of regional government*, Economic Working Paper Series, <http://www.csis.or.id/papers/wpe054> (in Indonesian).
- Aisyah, S., (2008), *Economical potency of sand mining on the Gendol river*, Thesis presented to Gadjah Mada University (in Indonesian).
- Directorate General of Water Resources (DGWR), Republic of Indonesia, (2001a), *Review master plan study on Mount Merapi, main report*.
- Directorate General of Water Resources (DGWR), Ministry of Settlement and Regional Infrastructure, Republic of Indonesia, (2001b), *Review master plan study on Mt Merapi, supporting report [B] volcanic disaster*.

- Directorate General of Water Resources (DGWR), Republic of Indonesia, (2001c), *Review master plan study on Mt Merapi. supporting report [C] regional development and sustainable sand mining.*
- Directorate General of Water Resources (DGWR), Republic of Indonesia, (2001d), *Review master plan study on Mt Merapi. supporting report [D] hydrology.*
- Directorate General of Water Resources (DGWR), Republic of Indonesia, (2001e), *Review master plan study on Mt Merapi. supporting report [E] geology and volcanology.*
- Indra Karya, (1999), *Survey of sediment balance and management in Progo River*, final report (in Indonesian).
- Kondolf, G.M., (1997), *Hungry water: effects of dams and gravel mining on river channels*, Environmental Management Vol. 21, No. 4, 1997, pp. 533-551.
- Lavigne, F., Thouret, J.C., Voight, B., Suwa, H., and Sumaryono, A., (2000), *Lahars at Merapi volcano, Central Java: an overview*, Journal of Volcanology and Geothermal Research, Vol. 100, pp. 423-456.
- Lavigne, F., and Thouret, J.C. (2002), *Sediment transportation and deposition by rain triggered lahars at Merapi volcano, Central Java, Indonesia*, Journal of Volcanology and Geothermal Research, Vol. 49, pp. 45-69.
- Mananoma, T., Rahmat, A., and Legono, D., (2006), *Prediction of sediment storage capacity of Gendol River after eruption of Mount Merapi in 2006*, Proc. Annual Meeting of Indonesia Association of Hydraulic Engineering, XXIII, Manado, Indonesia.
- Mananoma, T., (2008), *Sediment transport modeling on the middle reach of Progo river as a basis of management*, Thesis presented to Gadjah Mada University (in Indonesian).
- Marfai, M.A., King, L., Singh, L.P., Mardiatno, D., Sartohadi, J., Hadmoko, D.S., and Dewi, A., (2008), *Natural hazards in Central Java province, Indonesia: an overview*, Environ Geol, Vol. 56, pp. 335-351.
- Siswowidjoyo, S., Suryo, I., and Yokoyama, I., (1995), *Magma eruption rates of Merapi volcano, Central Java, Indonesia, during one century (1890-1992)*, Bulletin Volcanology, Vol.57, pp.111-116.
- Sumaryono, A., Churiyah, and Artha, I.G.M, (1996), *Geomorphologic changes of Kali Progo caused by lahar flow from Mt. Merapi*, Proceedings of Workshop on Disasters Caused by Floods and Geomorphological Changes and Their Mitigations, Yogyakarta, Indonesia , pp. 198-202.
- Suryadi, A., and Sumarto, S., (2003), *Poverty and vulnerability in Indonesia before and after the economic crisis*, Asian Economic Journal, Vol. 17, pp. 45-62.
- Sutikno, H.S, Djamel H., Suprijatin, and Satriyatni, (2003) *Investigation of Sand mining impact on stability of river structures in volcanic deposition area* (in Indonesia).
- Sutiarno, H. (2006), *Analysis of sediment movement and its impact on degradation of Progo River*, Thesis presented to Gadjah Mada University (in Indonesian).
- Thouret, J.C., Lavigne, F., Kelfoun, K., and Bronto, S., (2000), *Toward a revised hazard assessment at Merapi volcano, Central Java*, Journal of Volcanology and Geothermal Research, Vol. 100, pp. 479-502.
- Voight, B., Constantine, E.K., Siswowidjoyo, S., and Torley, R., (2000), *Historical eruptions of Merapi volcano, Central Java, Indonesia, 1768-1998*, Journal of Volcanology and Geothermal Research, Vol. 100, pp. 69-138.

Chapter 4

A Method for Effect Evaluation of Sediment Management

4.1 Introduction

The meaning of sediment management is generally the human intervention to control sediment discharge. The human intervention is needed when sediment production is in huge condition. If there is huge sediment production, sediment disaster due to debris flows and riverbed aggradation will take place. Human makes intervention to control sediment flow by sediment control structures such as sabo works and channel works. Also, if sediment production is too little, the condition will cause problems such as degradation problem.

The purpose of sabo works is to protect mountain area by controlling the excess sediment discharge. The sabo works will provide adequate disaster prevention function. However, the environmental problems will appear, because the structures cause river incision and capture most of sediments, resulting in bed degradation in downstream site. In order to decrease its negative impact, sabo works are equipped with fish way, thus, fish can travel up and down. Sometimes the slits are equipped for the sabo dams. Sediment can flow through the slit during low flow.

Channel works are constructed to prevent local scouring in order to make river structure stable condition. Similar to sabo works, the structures also cause the degradation of averaged bed level, thus people equip with fish ways in the structure.

Sediment management is commonly addressed to achieve an expected condition due to some reasons. For example, people manage sediment for the life span of reservoir maintenance reason, water quality improvement reason, flood risk reduction reason and so on. The definition of sediment management here are activities/actions to control sediment by regulating sediment utilization, channel

works, and sabo works. Safety, river environment, and sediment utilization are the elements of the target of sediment management. The priority among three elements depends on stakeholders. Sediment management is called a good management, if the result of the activity will go toward to expected targets. For example, if sediment management is conducted to protect human life from sediment disaster and increase human safety, so the sediment management is a good management. Conversely, if the result goes to opposite direction of the target, the sediment management is a not good management. Of course, achievement to all the targets needs a big effort. However, in this paper, integrated sediment management with considering among three targets is attempted to be developed. In addition, a change in an element by sediment management will affect the other two elements. Furthermore, changes in environment, safety, and utilization elements by a sediment management policy will cause a change in a socio-economic condition. Therefore, perfect sediment management that can achieve the all targets is quite difficult to be made.

Regarding the environment target, people give attention on bed variation, bed material changes and turbidity. From the safety point of view, sediment is managed in order to secure people and assets from sediment disasters, riverbed stabilization, riverbank protection, and sedimentation control in a reservoir. On the other hand, people also use sediment as resources such as construction material, agriculture land, and sand for beach. Figure 4.1 shows a diagram that describes targets of sediment management.

Changes in one target by sediment management will affect the other two targets. For example, when people regulate a sand mining activity, their action will give directly the impact on the utilization target. Moreover, the regulation also changes the environment and the safe situation indirectly. For another example, if people make a policy on sediment management addressed to secure human life and assets from sediment hazard by constructing sabo works, the policy gives impacts on environment and sediment utilization as well as safety. The sabo works will capture the transported sediment and protect people from disaster. Furthermore, the sediment deposition in the upper site of the structures reduces sediment discharge to downstream area, resulting in bed degradation. Hence, it is very clear

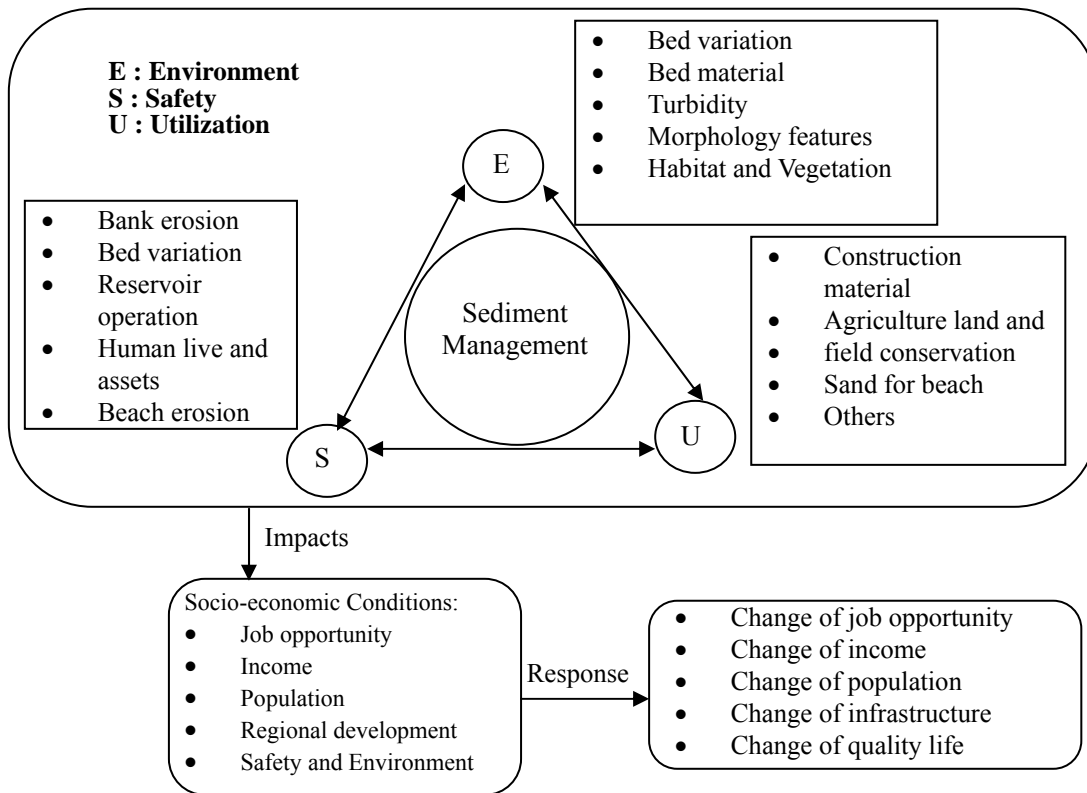

Fig. 4.1 A diagram of impact of sediment management on environment and socio-economic

that sediment management can lead a good situation for a target but not for the other targets.

Furthermore, a change in the environment, safety, and utilization targets by a policy of sediment management will cause a change on the socio-economic condition. In this paper, job opportunity, income, population changes, and quality of life are used as parameters of the socio-economic condition. For example on sediment management in Mount Merapi basin, sediment disaster mitigation projects have been started since 1930s after huge eruption in 1931 (DGWR, 2001b). The sediment disaster mitigation system has been actively prepared since 1980s by constructing sabo works in surrounding Mount Merapi basin. Those sabo facilities have contributed to peoples' safety and assets. For example, 39 casualties and 812 lost houses were caused by debris flows from 1969 to 1976, while there was only one

casualty since 1980s. Moreover, the sabo facilities also have contribution to regional development by providing transportation access and irrigation facilities. Consequently, it is encouraged for people to move for water and sediment resources use to the slopes of Mount Merapi. Thus, agriculture production increased and population in mountainous area changed fast.

On the other hand, due to the good quality of deposited sediment for construction material, people take the sediment as a resource by sand mining activity. The activity has provided job opportunities for local people, given additional income for local people in foothill of Mount Merapi and downstream of Progo River, and given tax for local government. However, the activity also has given the negative impacts such as instability of river structure, riverbed degradation, road damages, noise, and dust. Finally, the quality of life will deteriorate. Photo 4.1 shows a sand mining activity and its impact on the environment condition in Mount Merapi. To evaluate effect of sediment management on environment, sediment utilization and safety will be discussed in this chapter.

4.2 Evaluation of Sediment Management

4.2.1 Introduction

The sediment management shown in sub-section 3.4.3 will be used as case studies of sediment management that to be evaluated from socio-economic and environment aspects. The each of evaluation aspect is described as follows. Regarding the sediment problem in the Mount Merapi basin, there are three options to face the sediment disaster as shown in Table 4.1. The option framework has been developed based on Kelman and Mather (2008).

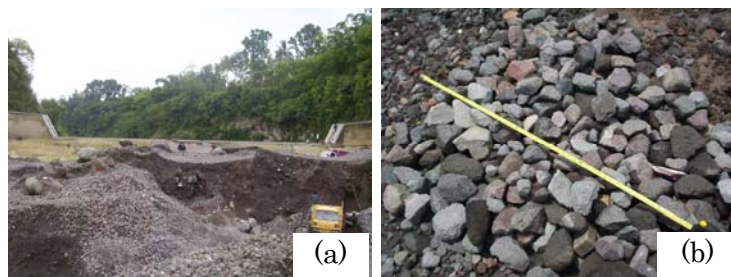

Photo 4.1 (a) A sand mining activity on Gendol River, (b) artificial armoring caused by sand mining activity

Figure 4.2 shows direction of change in socio-economic and environmental aspects for three options. The first option against the sediment disasters is to do nothing. It means no sediment management. The change in situation by the first option can be described by line 1 in Figure 4.2. Here, we accept that sediment related disaster only happen. It is well documented that pyroclastic and debris flows have caused serious damages around Mount Merapi. For examples, the pyroclastic flow due to the 1930 eruption has burned the area of 20 km², caused 1,369 casualties, and swept 13 villages (DGWR, 2001b). It means if no sediment management, the disaster will give negative impact for social, economical, and environmental aspects in the area where the disaster happens.

The second option is to protect a society from the sediment disasters by sediment disaster mitigation. To reduce the negative impacts of the excess sediment discharge, commonly, sabo dams are used to protect a society and assets in downstream from sediment disasters. The dams can capture almost all transported sediment from upstream and the sediment was deposited on their upstream side, finally, riverbed degradation takes place in downstream area. Moreover, the closed type dams prevent the fish travel from downstream to upstream. In other words, we can say that the second option will give positive impacts for socio-economic condition, but it still causes negative impacts for environment. The change in situation by option 2 is shown by line 2 in Figure 4.2.

The change by the ideal option is shown by line 3 in Figure 4.2. Most stakeholders attempt to achieve sediment management giving positive impacts on a socio-economic condition and making an environmental condition better.

Table 4.1 Option and consequences for dealing with sediment related disasters

Option for dealing with sediment related disasters	Main implications
1. Do nothing	Disaster occur
2. Protect society from disasters by disaster mitigation	Not always feasible, sometimes environmental problems take place
3. Live with disasters	Livelihoods are integrated with sediment threats and opportunities, considering sustainability of environment

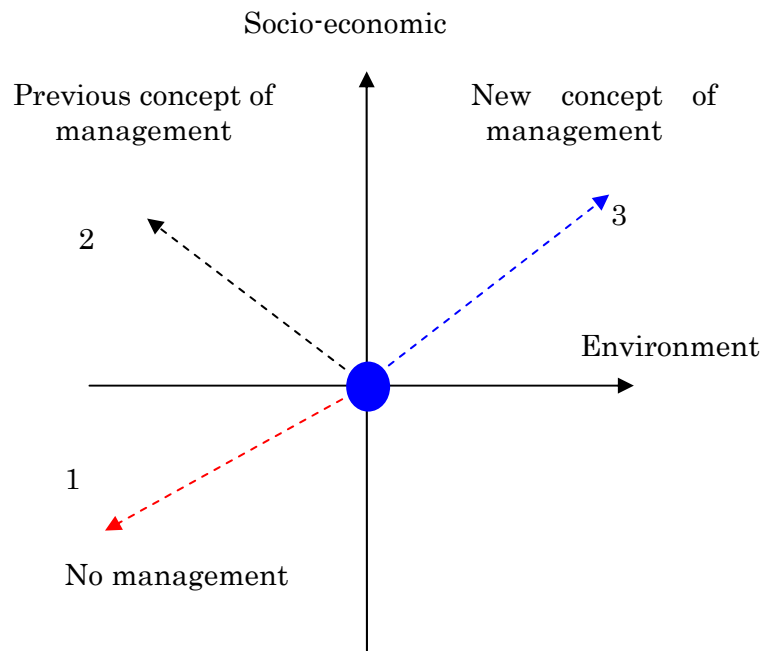

Fig. 4.2 The directions of the impacts of sediment management on socio-economic and environment

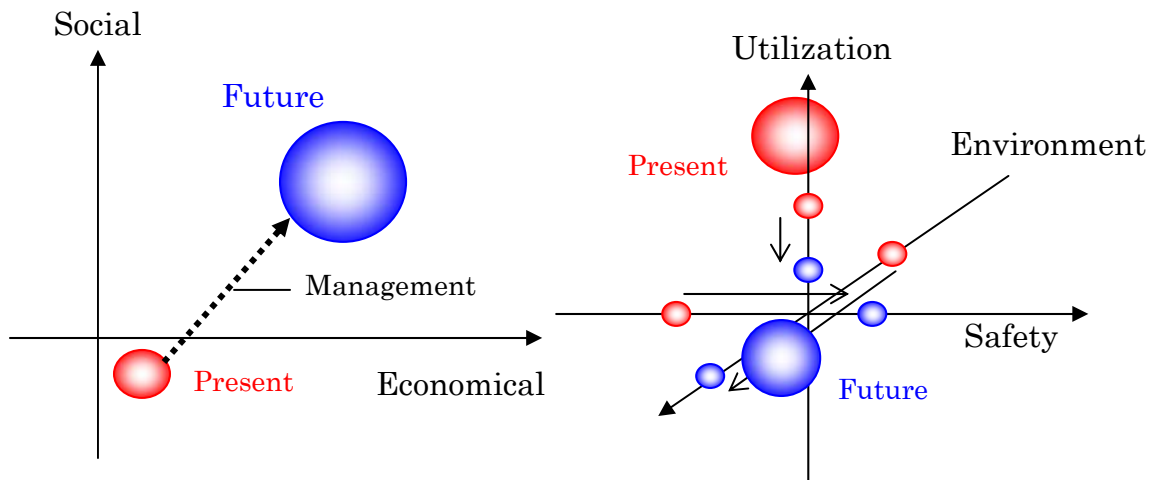

Fig. 4.3 The expected result of proposed sediment management on (a) socio-economic, (b) utilization, safety and environment

4.2.2 Socio-economic aspect

The case study of sediment management generally consists of three main components, namely controlling sand mining, riverbed stabilization in the lower Progo River and the disaster mitigation. The effect of the case study of sediment management on socio-economic aspect will be evaluated based on these three main components.

(1) Sand mining control

The effect of sediment management on socio-economic conditions are evaluated by changes in job opportunity, additional income of inhabitants, sand mining tax of local governments, infrastructure development and so on. In this paper, changes in job opportunity and sand mining tax are used to evaluate the effect of sediment management on this aspect. Effect of sand mining control on socio-economic are divided into 3 parts, namely: a) Effect on local people, b) Effect on distributor/company and c) Effect on local government.

a) Effect of sand mining control on local people

In this paper, effect of sand mining control on socio-economic of local people will be evaluated by changes in job opportunity and additional income of inhabitants. The data in 1999 presented by DGWR (2001b) is used as the initial data for analysis. The number of sand miner was estimated at 21,022 persons/day, and the produced sand mining volume was about 25,683 m³/day. If the workable day is assumed 20 days/month, the annual sand mining volume is estimated at 6,163,920 m³/year. It means one sand miner produces 1.22 m³/day. According to Aisyah (2008), the price of sand in Mount Merapi basin is about 20,000 rupiah/m³. If all sediment production flows down into lower area, such as in the Case 1 (in sub-section 3.4.2), it means that sand mining should be prohibited totally. Assuming the number of sand miner in every day is constants, this condition in the Case 1 will cause the loss of job opportunity for inhabitant to be estimated at about 21,022 persons/year as shown in Figure 4.4. It means the total loss of daily income of inhabitants is approximately 512 million rupiah/day. The total loss of daily income for every case of proposed sediment management is shown in Table 4.2.

In the Cases 2a and 3a, the loss of job opportunity for local people is small compared with the other cases. Loss of job opportunity of both cases each year is 16,104 people. The total loss of daily income of inhabitants is about 392 million rupiah/day. The loss of job opportunity in the Cases 2b and 3b every year is 18,567 people and the total loss of daily income of inhabitants is estimated at 452 million rupiah/day. From Table 4.3 and Figure 4.4, it indicates that the sand mining activity in Mount Merapi is important for local people from socio-economic aspect. If

the government of Indonesia plans to regulate sand mining activity, the most important one is how to provide an alternative job for them. The problem is not quite complex. Moreover, the sand mining demand tends to increase from year to year. Based on this situation, we can understand why the law/regulations to prohibit the sand are quite difficult to be applied in Mount Merapi. As long as no alternative job for them, the sand mining activity will continue.

It is considered that an education program and regional development for local people are effective to control sand mining activity. By an education program, the awareness of local people on their environment is expected to increase. They will understand well about the negative impact of un-controlled sand mining activity. The regional development can be done through the development in agriculture sector, so that the alternative job can be created for them, especially livestock farming of cow and goat.

Table 4.2 Total loss of daily income of inhabitants

Cases	Sand mining volume (m ³ /year)	Total number of sand miner (person/day)	Total income of local people (million rupiah/day)	Total loss income of local people (million rupiah/ day)
Initial	6,163,920	21,022	512	-
Case 1	0	0	0	512
Case 2a	1,440,000	4,918	120	392
Case 2b	720,000	2,459	60	452
Case 3a	1,440,000	4,918	120	392
Case 3b	720,000	2,459	60	452

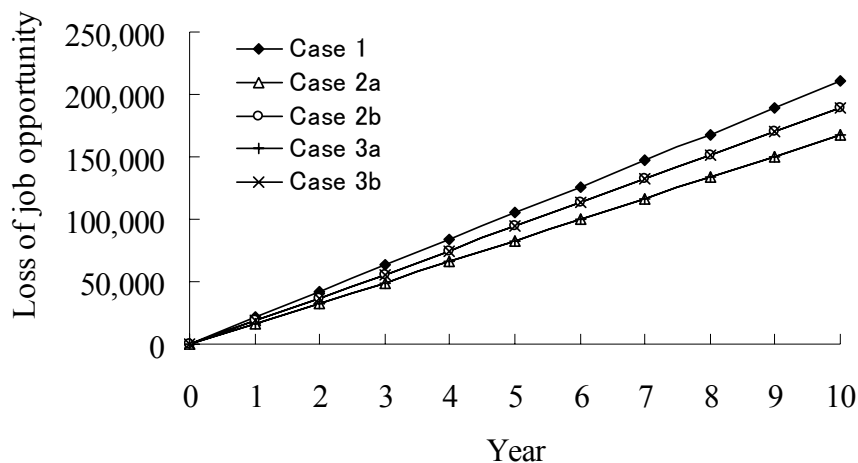

Fig. 4.4 Impact of sediment management on loss of job opportunity

b) Effect of sand mining control on distributor/transportation company

Sand mining control influence not only for local people/sand miner, but also for transportation company/distributor of sand. Generally, workers of one truck with volume of 4.5 m³ consist of driver and co-driver. If the current situation of sand mining is maintained, it needs about 5,700 unit trucks a day for transporting sand. Here, we assumed that one truck can services 2 times a day, so that the sand mining activity requires 2,850 trucks with 5,700 workers. Therefore, if the sand mining management will be applied, it will reduce the number of the transportation workers. For example, the sediment management in the Case 1 will cause the loss of job opportunity for 5,700 workers/day. The number of the loss of the job opportunity for driver/co-driver and truck for case studies presented in Chapter 3 is shown in Table 4.3. If we assumed that daily income for driver/ co-driver is 75,000 rupiah, the lost of potential income in the Case 1 is 427.5 million rupiah. From this result we can conclude that sand mining helps economy profitable. Therefore, it can be understood that the sand mining in Mount Merapi tends to be active.

Usually, sand from Mout Merapi is distributed to the main cities in Central Java and Yogyakarta, such as Semarang, Magelang, Yogyakarta and Surakarta. The price of one truck with volume of 4.5 m³ is depends on the distance, and the average price is 400,000 rupiah/truck. The income of transportation company/distributor can be calculated as follows.

Table 4.3 Total loss of daily income of driver/co-driver

Cases	Sand mining volume (m ³ /year)	Total number of worker (person/day)	Total income of worker (million rupiah/day)	Total loss income of worker (million rupiah/day)
Initial	6,163,920	5,700	427.5	-
Case 1	0	0	0	427.5
Case 2a	1,440,000	1333	99,9	327.6
Case 2b	720,000	666	49,95	377.55
Case 3a	1,440,000	1333	99,9	327.6
Case 3b	720,000	666	49,95	377.5

Costs component:

• Cost in Mount Merapi	90,000 rupiah /truck
• Lunch for driver/co-driver	30,000 rupiah/truck
• Salary for driver/co-driver	75,000 rupiah/truck
• Retribution/tax	7,500 rupiah/truck
• Gasoline	50,000 rupiah/truck
<i>Total costs</i>	252,500 rupiah/truck
Sale of sand	400,000 rupiah/truck
Benefit	<i>147,500 rupiah/truck</i>

The potential income for distributor/transportation company is estimated at 147,500 rupiah/truck. Present situation of sand mining activity requires about 5,700 unit trucks, so that potential income of transportation company/distributor is about 840 million rupiah/day.

c) Effect of sand mining control on local government

The effect of sediment management on local government can be evaluated by tax income. By year 1999, the sand mining tax income of the local governments in the surrounding Mount Merapi basin is about 1,014 million rupiah. If we assume that the relationship between the sand mining tax and sand mining volume is linear, the lost of tax income of local government is shown in Figure 4.5. In the Case 1, the loss of tax income is estimated at 1,014 million rupiah/year. In the Cases 2a and 3a, the loss of tax income is about 777.1 million rupiah/year. For the Cases 2b and 3b, the loss of tax income is about 895.5 million rupiah/year.

Figure 4.6 shows the effect of sediment management on socio-economic conditions. If the sediment management under a current condition is maintained, it will provide great benefits in socio-economy. Local people have large opportunity to get job as sand miners and local governments get an additional tax. All the proposed sediment management will cause decreasing employment opportunity and declining additional revenue. Sediment management in the Case 1 has the greatest negative impact. The Cases 2a and 3a have the smallest impact, while the Cases 2b and 3b have the medium impact.

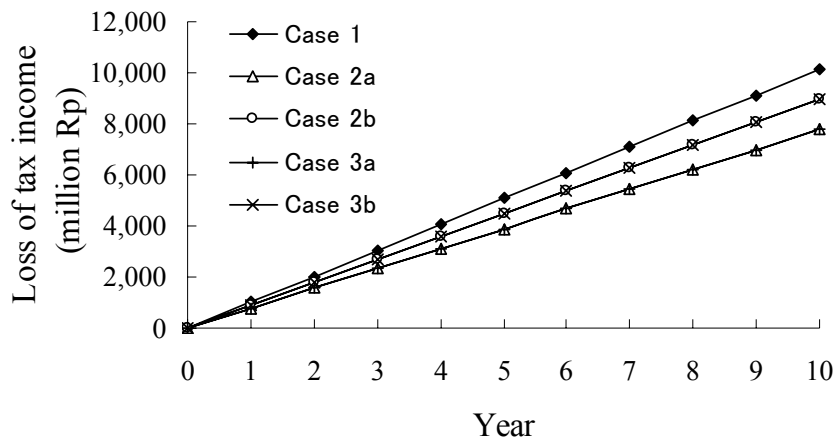

Fig. 4.5 Impact of sediment management on loss of tax income

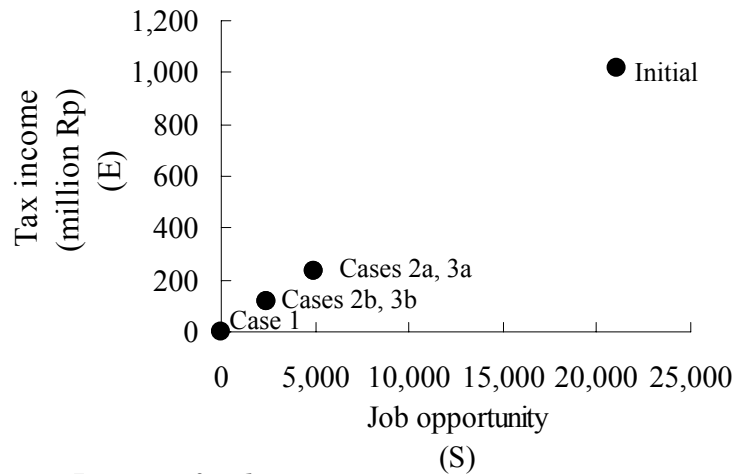

Fig. 4.6 Impact of sediment management on socio-economic condition

(2) Riverbed stabilization

The sediment management gives impacts in the upper area and lower area. As described in Chapter 2, the severe riverbed degradation has taken place in the lower Progo River, resulting in instability of the public infrastructure, as bridges and irrigation intakes. To overcome the current situation of riverbed degradation needs a quick response, especially to re-functionalize and maintain two irrigation intakes in Kamijoro and Saphon. The both irrigation intakes are very important to irrigate the rice fields in the Bantul and Kulon Progo Districts. The area of the rice fields in the both districts is estimated at 4,500 ha. If it is assumed that the annual production of the rice fields is 14.76 million rupiah/ha (DGWR, 2001a), its economical potency is about 66,420 million rupiah/year or 181.9 million rupiah/day.

In the Case 1, the riverbed along the lower Progo River can be stabilized by sediment supply from Mount Merapi. However, due to no ground sill installation in the lower Progo River, the riverbed degradation cannot be solved immediately. Therefore, the sediment management in the Case 1 has not given the positive impact on socio-economic of inhabitants in the both districts. In the Cases 2a and 2b, the riverbed degradation occurred in the lower Progo River, so that the both managements will cause the current situation of riverbed degradation to be worse. From the interest of people in the lower Progo, it is necessary to overcome the riverbed degradation in the area soon, so that the stability of main infrastructure can be maintained. Hence, the ground sill installation is one method to stabilize and against riverbed degradation in the lower Progo. Therefore, the sediment management using ground sills, such as the Cases 3a and 3b, is most reasonable to solve current situation of the riverbed degradation in the lower Progo as well as in the downstream of Opak River. Moreover, benefit associated with riverbed stabilization in the downstream area is benefit associated with bridge protection. However, sometimes the benefit is difficult to be quantified exactly. The benefits consist of lost cost by detour due to bridge collapse and cost for reconstruction. Hence, the stability of bridges and irrigation water intakes are important. To evaluate the stability of the structures will be discussed as follows.

a) Effect of sediment management on river facility structure

The effect of sediment management on river facility structures will be investigated at 7 points, namely at 30 km, 20 km, 18 km, 14 km, 11 km, 9 km and 2 km from the downstream boundary end. The two river facility structures, namely bridge and water irrigation intake are used as case studies.

- Bridge structure

Effect of sediment management on river structures is calculated by estimating the risk of river structures. For a bridge structure as shown in Figure 4.7, the risk is discussed from the three parameters, namely P_1 (the risk of the foundation function), P_2 (the risk of the pier function) and P_3 (the risk of the bridge function). The value of

riverbed variation (Δz) is negative if bed degradation occurs and positive if bed aggradation takes place. P_1 , P_2 , and P_3 are calculated by the following equations:

$$P_1 = \frac{\Delta z}{Hf} \quad (4.1)$$

$$P_2 = -\frac{\Delta z}{Hp} \quad (4.2)$$

$$P_3 = -\frac{H_w + \Delta z}{Hp} \quad (4.3)$$

where H_w is the depth of water. Critical condition is achieved if the values of P_1 , P_2 and P_3 are equal to -1. If P_1 , P_2 and P_3 are greater than -1, it shows that the bridge is in a safe condition. If P_1 is equal to -1, it means that the foundation tends to collapse due to river degradation. P_2 is equal to -1, it means that piers are completely buried by sediment; consequently the pier function is in a crucial condition. Water will flow over the bridge, if P_3 is equal to -1. Risk degree of the structure can be calculated using the following equations.

$$RP_1 = -P_1 \times 100\% \quad (4.4)$$

$$RP_2 = -P_2 \times 100\% \quad (4.5)$$

$$RP_3 = -P_3 \times 100\% \quad (4.6)$$

If RP_1 , RP_2 and $RP_3 > 0$, it indicates the level of risk degree of the bridge structure. Nevertheless, if RP_1 , RP_2 , and $RP_3 < 0$, it means the structure is in a safe condition.

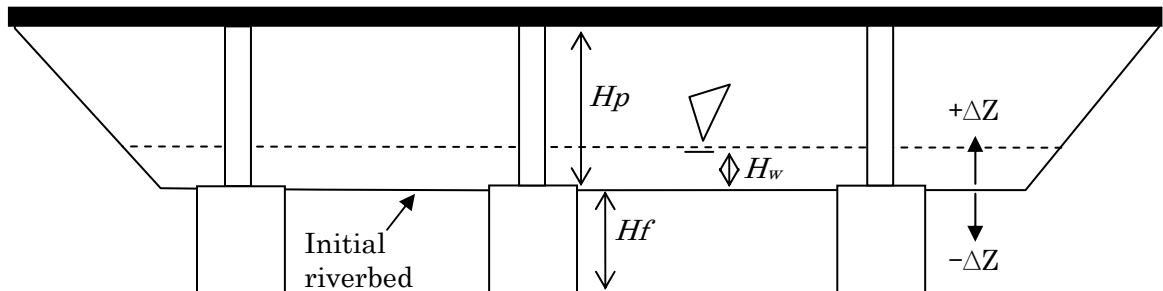

Fig. 4.7 Sketch of a bridge

A data set of a bridge structure is used to evaluate effect of sediment management on a bridge structure. Here, Kebon Agung bridge with a pier height (H_p) of 11.75 m, a foundation depth (H_f) of 6.0 m (assumed), is used as a case study. The Kebon Agung bridge has 153.6 m span and 7 m width. It was constructed in 1986 to connect Sleman district to Kulon Progo district. The data will be used at the seven points.

Figure 4.8 shows the effect of sediment management on the parameters P_1 , P_2 , and P_3 ; and on the risk degree of the parameters P_1 , P_2 , and P_3 at point 30 km upstream from downstream boundary end. From the figure, it indicates that the values of all parameters are greater than -1. It describes that no case gives unsafe conditions to the bridge structure. However, the Cases 2a, 2b, and 3a require attention because of the risk of the foundation function tends to increase. The risks of the pier and bridge functions have a tendency to enlarge in the Cases 1 and 3b. However, changes in both parameters are not so fast.

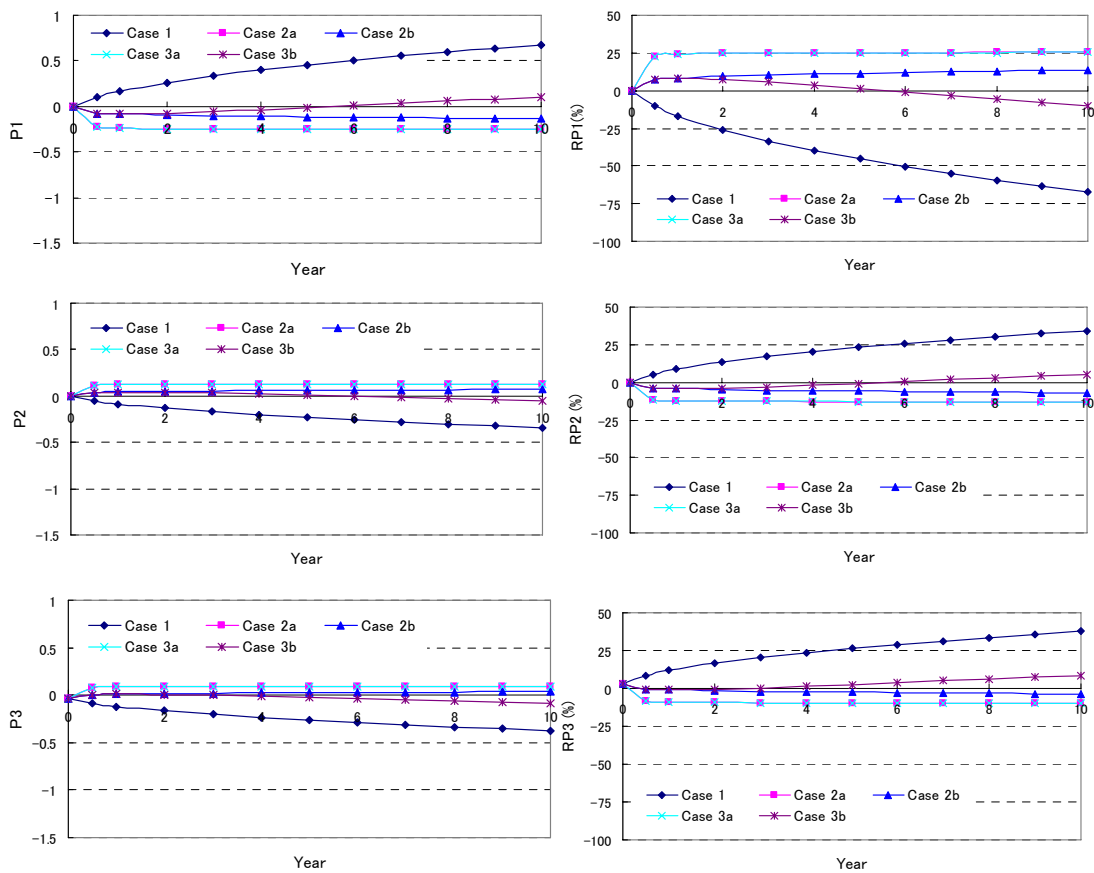

Fig 4.8 Effect of sediment management on the parameters P_1 , P_2 , and P_3 ; and risk degree of the parameters P_1 , P_2 , and P_3 at 30 km from downstream boundary end

The effect of sediment management on the parameters P_1 , P_2 , and P_3 ; and on the risk degree of the parameters P_1 , P_2 , and P_3 at points 20 km, 18 km, 14 km, 11 km, 9 km and 2 km upstream from downstream boundary end are shown in Figures 4.9, 4.10, 4.11, 4.12, 4.13 and 4.14, respectively. At the point 20 km, no case gave the negative effect on a bridge structure. It is indicated by the values of parameters P_1 , P_2 , and P_3 are greater than -1. The similar conditions to the points 30 km and 20 km also take place in the five other points. However, the Case 3b gave the smallest impact on a bridge structure than the other cases. If the simulation results are compared with the recent condition of riverbed degradation, it tends that the results are still under estimated. The reasons why the simulation results under estimated are as follows:

- a) the simulations did not consider the sand mining activity in Progo River, especially in the lower reach,
- b) the simulations used the annual average water discharge, and
- c) the simulations still considered that the sediment production was constant.

According to Indra Karya (1999), the sand mining volume in the lower Progo River was estimated at 1.07 million m³/year. The sand mining activity in the lower reach Progo River raises serious problem for riverbed stability, especially for stability of a bridge structure. Based on the simulations results, it shows that one solution to stop riverbed degradation in the lower reach is prohibiting the sand mining activities in the lower Progo River. Referring to Chapter 2, the survey results described that sand mining activities have become one of occupations for local people in the lower area. To stop the sand mining activity needs another policy such as an empowerment community, so that local people can get a new occupation. Besides, water discharge in the Progo River is not constant, so that the condition will give effects on sediment transport in the river. If the annual average water discharge is used, the sediment transport tends to decrease after an armor layer is formed. Consequently, the riverbed degradation also tends constant from time to time. The sediment production in Mount Merapi basin is not constant, depends on Mount Merapi activity. Sometimes Mount Merapi produced the huge amount of sediment. Under the condition, the severe river bed aggradation will take place.

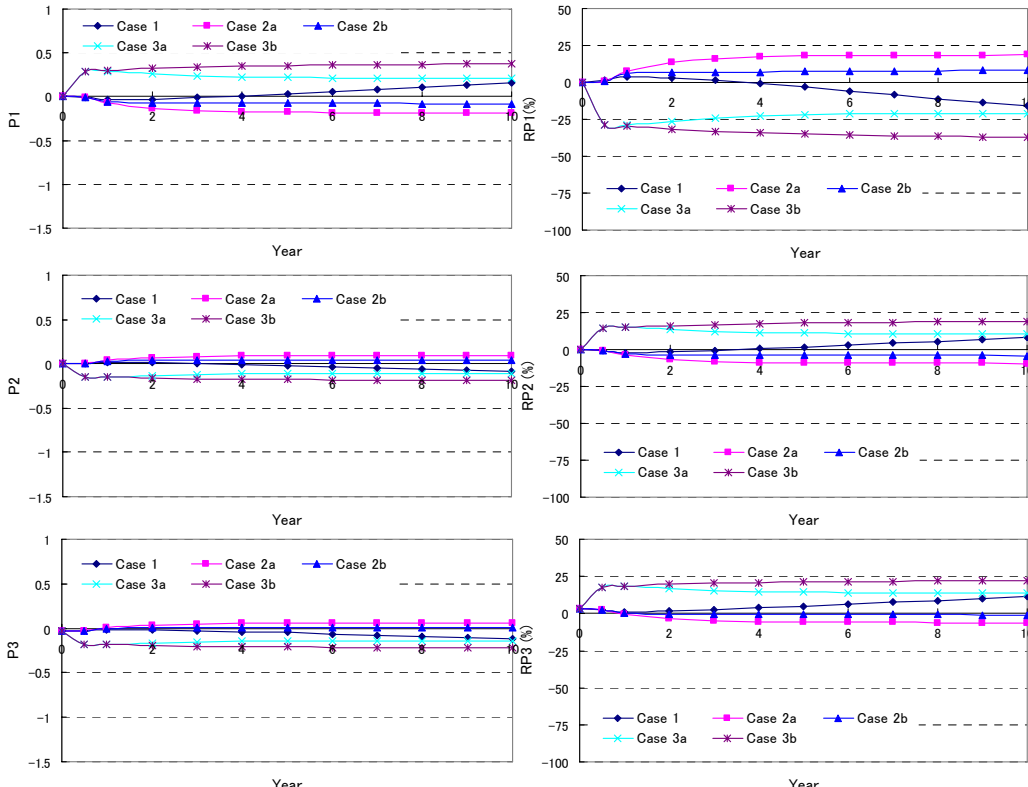

Fig 4.9 Effect of sediment management on the parameters P_1 , P_2 , and P_3 ; and risk degree of the parameters P_1 , P_2 , and P_3 at 20 km from downstream boundary end

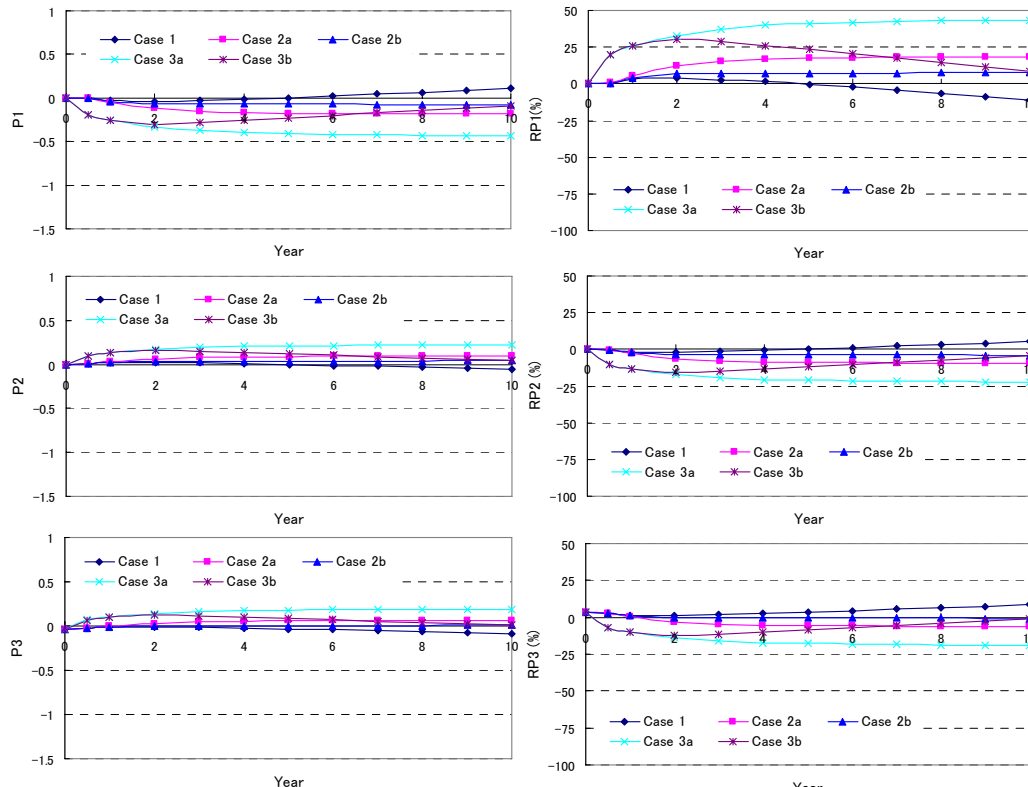

Fig 4.10 Effect of sediment management on the parameters P_1 , P_2 , and P_3 ; and risk degree of the parameters P_1 , P_2 , and P_3 at 18 km from downstream boundary end

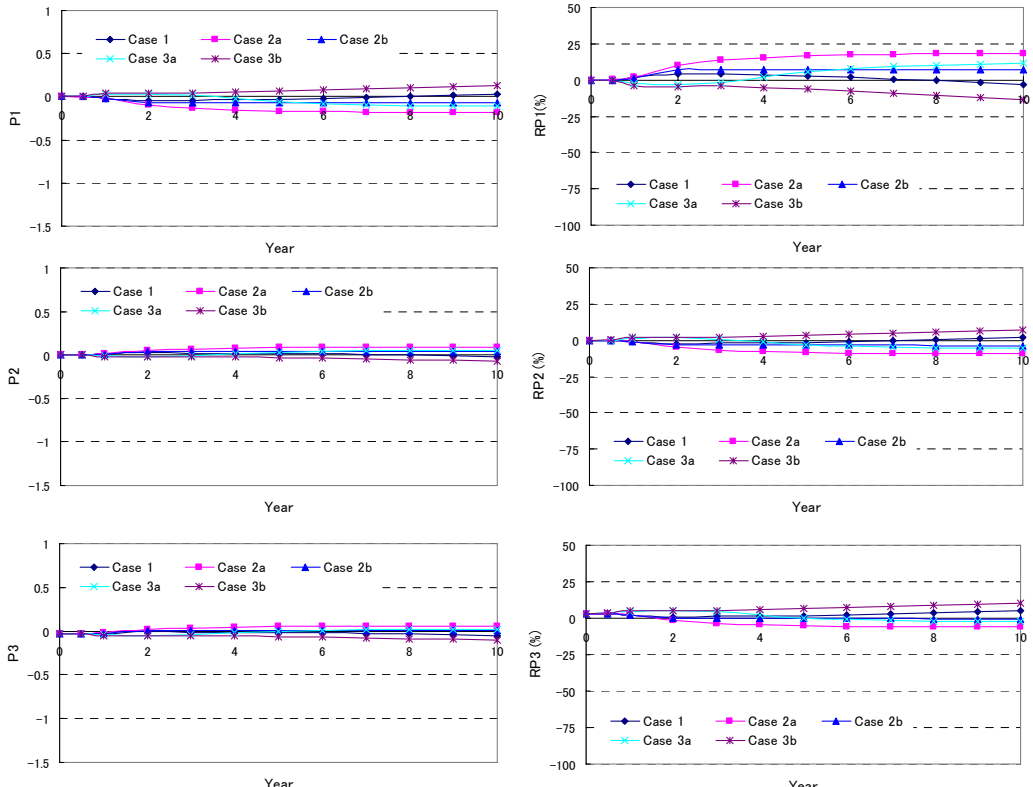

Fig 4.11 Effect of sediment management on the parameters P_1 , P_2 , and P_3 ; and risk degree of the parameters P_1 , P_2 , and P_3 at 14 km from downstream boundary end

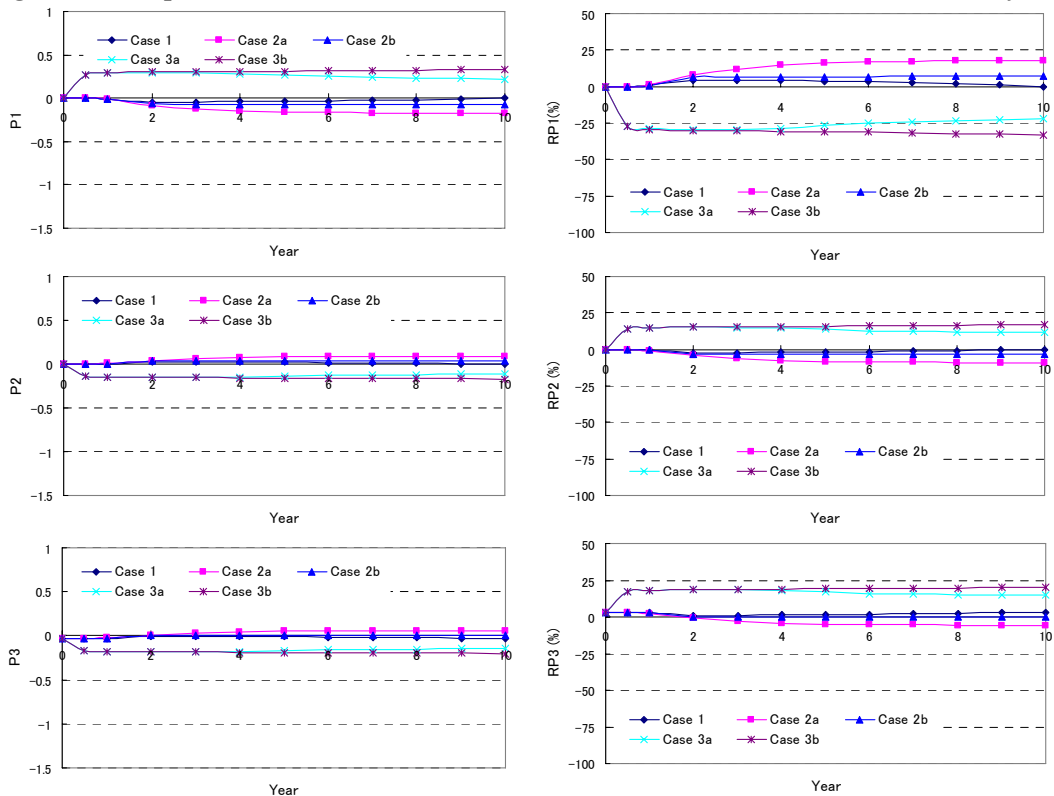

Fig 4.12 Effect of sediment management on the parameters P_1 , P_2 , and P_3 ; and risk degree of the parameters P_1 , P_2 , and P_3 at 11 km from downstream boundary end

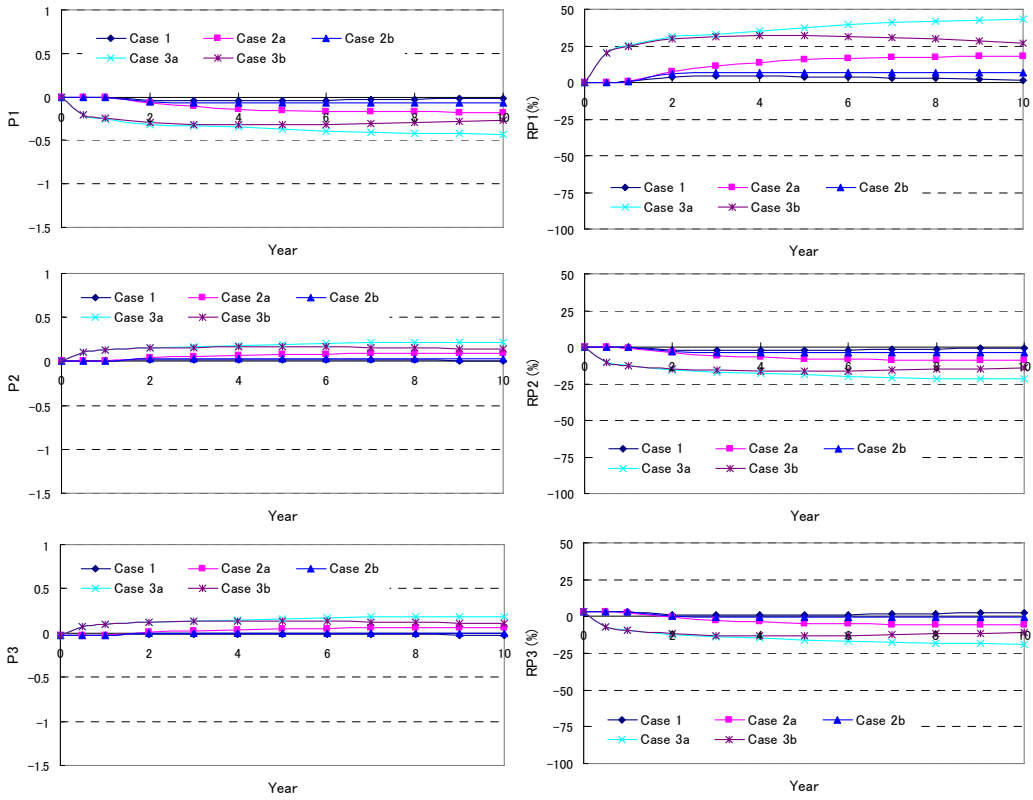

Fig 4.13 Effect of sediment management on the parameters P_1 , P_2 , and P_3 ; and risk degree of the parameters P_1 , P_2 , and P_3 at 9 km from downstream boundary end

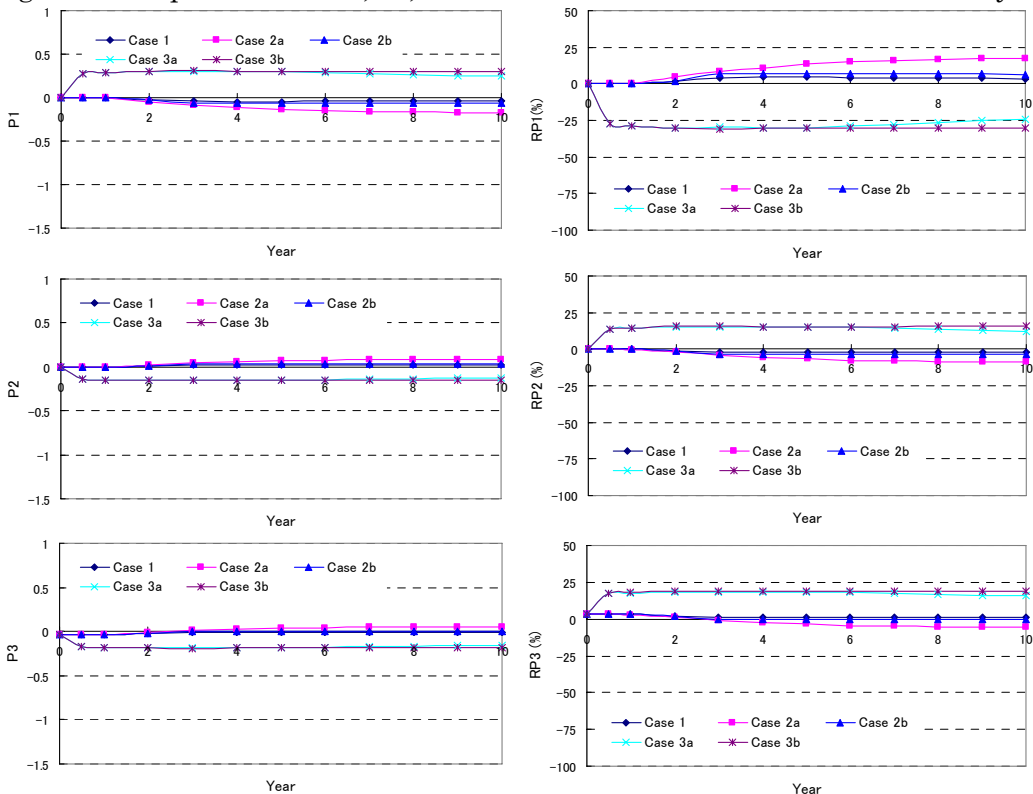

Fig 4.14 Effect of sediment management on the parameters P_1 , P_2 , and P_3 ; and risk degree of the parameters P_1 , P_2 , and P_3 at 2 km from downstream boundary end

-Irrigation intake

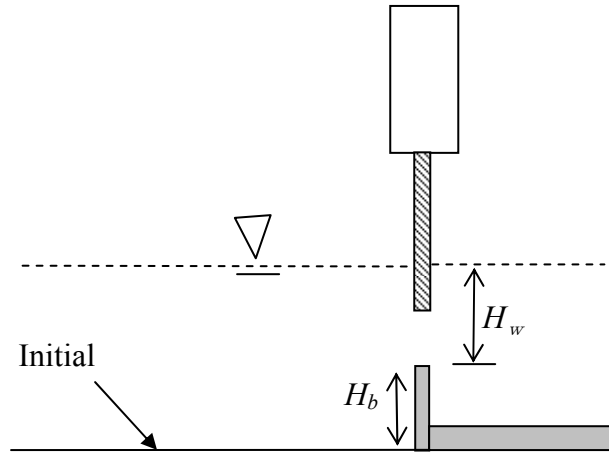

Fig. 4.15 Sketch of an irrigation intake

To calculate the risk degree of an irrigation intake as shown in Figure 4.15, a set of the following equations is proposed. For an irrigation intake structure, the risk is discussed from the two parameters, namely P_4 (the risk of sedimentation) and P_5 (the risk of water intake function). If P_4 is equal to -1, it indicates that sedimentation starts to take place in the irrigation channel. The irrigation intake has problem on serving to agriculture land because water cannot enter to the irrigation channel, if P_5 is equal to -1. In this paper, the risk degree of each of the parameter can be obtained using equation as follows.

$$P_4 = -\frac{\Delta z}{H_b} \quad (4.7)$$

$$P_5 = \frac{\Delta z}{H_w} \quad (4.8)$$

where H_b is the height from the riverbed to the crest of channel and H_w is the water depth above the crest of channel. The risk degree of an irrigation intake is calculated using the equations as follows.

$$RP_4 = -P_4 \times 100\% \quad (4.9)$$

$$RP_5 = -P_5 \times 100\% \quad (4.10)$$

The Kamijoro intake with H_b of 1 m and the H_w of 0.38 m (assumed) is used for a case study. The risk of sedimentation (P_4) and water intake function (P_5) at point 30 km upstream from downstream boundary end are shown in Figure 4.16. Figure 4.16 shows the value of parameter P_4 for the Case 1 is greater than -1. It means that if sediment management is conducted as the Case 1, the sedimentation in the irrigation channel will take place. In a 10-year period, the risk degree of sedimentation for the Case 1 is estimated at 400%. The sedimentation problem is also found for the Case 3b, although the risk degree of the sedimentation in the Case 3b is not so severe compared with the Case 1. Figure 4.16 also shows that the Cases 2a, 2b, 3a, and 3b have problems in the water intake function. Under this condition, the value of parameter P_5 is greater than -1. However, the problem in the water intake function for the Case 3b can be solved after 2 years due to the sediment supply from the upper area. Meanwhile, the risk degrees of the water intake function for the Cases 2a, 2b, and 3a tend to increase. Hence, the Case 3b is the most reasonable of sediment management from this point of view. Effects of sediment management on parameters P_4 and P_5 at points 20 km, 18 km, 14 km, 11 km, 9 km and 2 km from the downstream boundary end are shown in Figures 4.17, 4.18, 4.19, 4.20, 4.21 and 4.22, respectively.

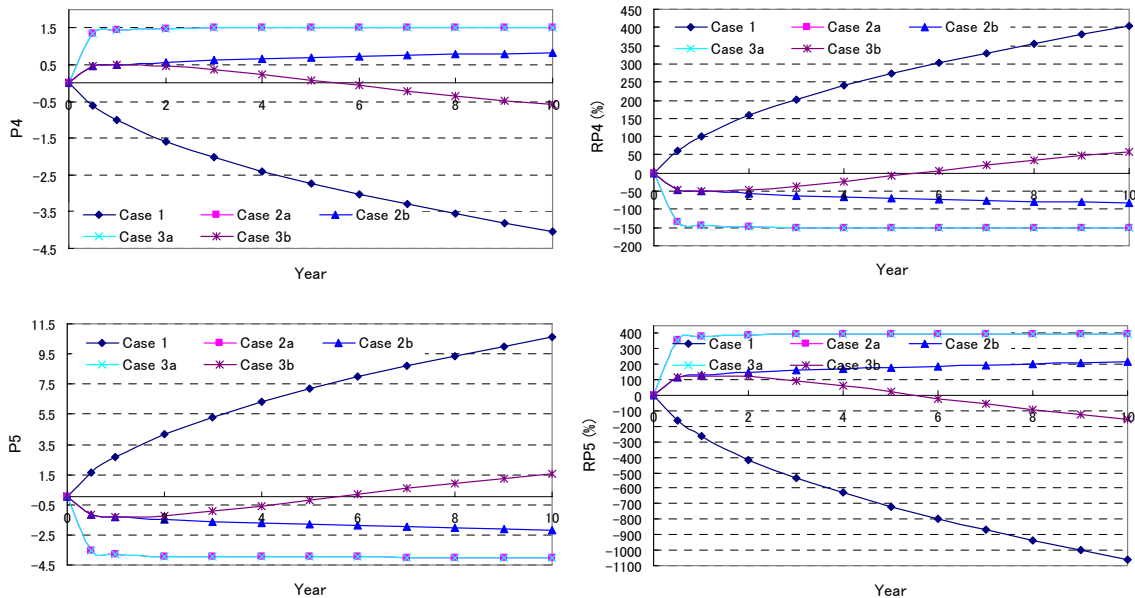

Fig 4.16 Effect of sediment management on the parameters P_4 , and P_5 , and risk degree of the parameters P_4 , and P_5 at point 30 km from downstream boundary end

Figure 4.17 shows that the sedimentation in the irrigation channel takes place in the Cases 1, 3a, and 3b. In the Cases 3a and 3b, the riverbed aggradation is caused by the ground sill installation, so that the riverbed elevation at this point increases. Meanwhile, the riverbed aggradation in the Case 1 is due to sediment supply from the upper area. Figure 4.17 also describes that water cannot enter to the irrigation channel due to degradation problems in the Cases 2a and 2b. In a 10-years period, the risk degree of the water intake function is estimated at 100% and 300% for the Cases 2a and 2b, respectively. The similar conditions to point 20 km also can be found at points 11 km and 2 km, as shown in Figures 4.20 and 4.22. However, the risk degrees of both parameters tend to decrease when the locations are near downstream boundary end, because degradation or aggradation in a downstream reach channel is smaller than in an upper downstream reach channel.

Figure 4.18 shows that risk of sedimentation, P_4 , is only found in the Case 1 after fifth years. In the first fifth years, no case has problem related the sedimentation in the irrigation channel. It indicates that the degradation takes place in all the Cases during 5 years. However, after the fifth years, the bed aggradation takes place in the Cases 1 due to the sediment supply from the upper area. Figure 4.18 also shows that a ground sill installation will cause degradation problem at downstream part of the ground sill. Consequently, the degradation will effect on the risk of water intake function, P_5 . In the Cases 2a, 2b, 3a, and 3b, the risk of water intake function is found at this point. The risk degrees of water intake function for the Cases 2a, 2b, 3a, and 3b are estimated at 300%, 100%, 700%, and 100%, respectively. From this results, it is indicates that if a ground sill is constructed, it will cause degradation at the lower part of the ground sill, because sediment will be captured by the ground sill. It needs an attention if channel works are used as part of sediment management. In the Case 3b, the supply sediment from the upper area can overcome the degradation in this point after 2 years. So that, the risk of water intake function in Case 3b can be decreased after 2 years. The similar condition to the point 18 km is also found at point 9 km as shown in Figure 4.21, although the risk degrees of the both parameters, RP_4 and RP_5 , tend to be smaller.

Figure 4.19 shows that the sedimentation problem in an irrigation channel is found in the Cases 1 and 3b. From the figure indicates that the sedimentation in the

Case 3b is larger than in the Case 1. However, the sedimentation in the both cases is not so serious. Figure 4.19 also shows that the risk of water intake function can be found in the Cases 2a, 2b, and 3a due to riverbed degradation. From the results, it shows that the Cases 1 and 3b are reasonable sediment management.

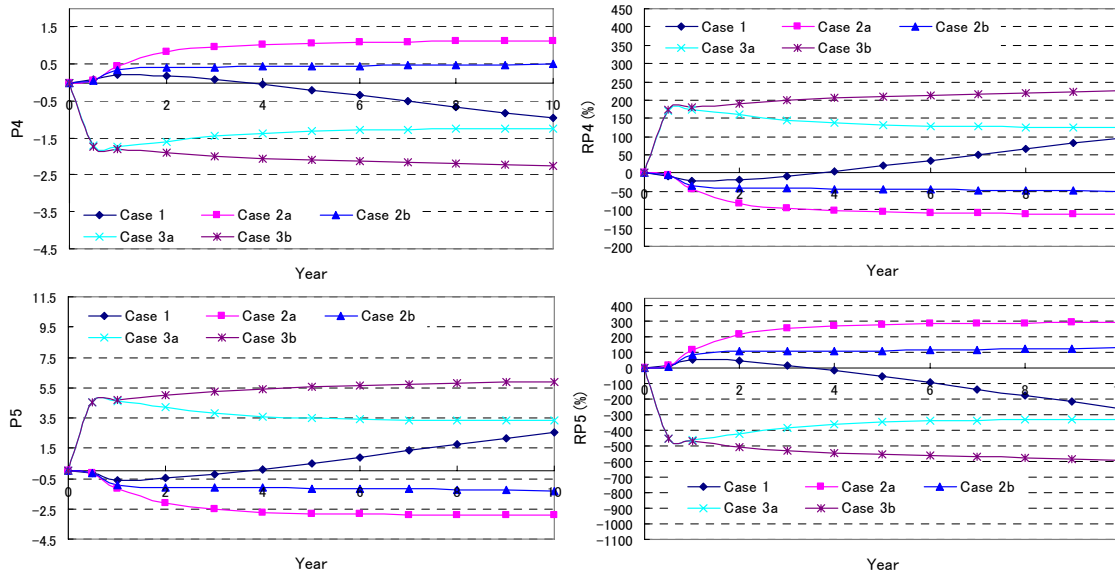

Fig 4.17 Effect of sediment management on the parameters P_4 , and P_5 , and risk degree of the parameters P_4 , and P_5 at point 20 km from downstream boundary end

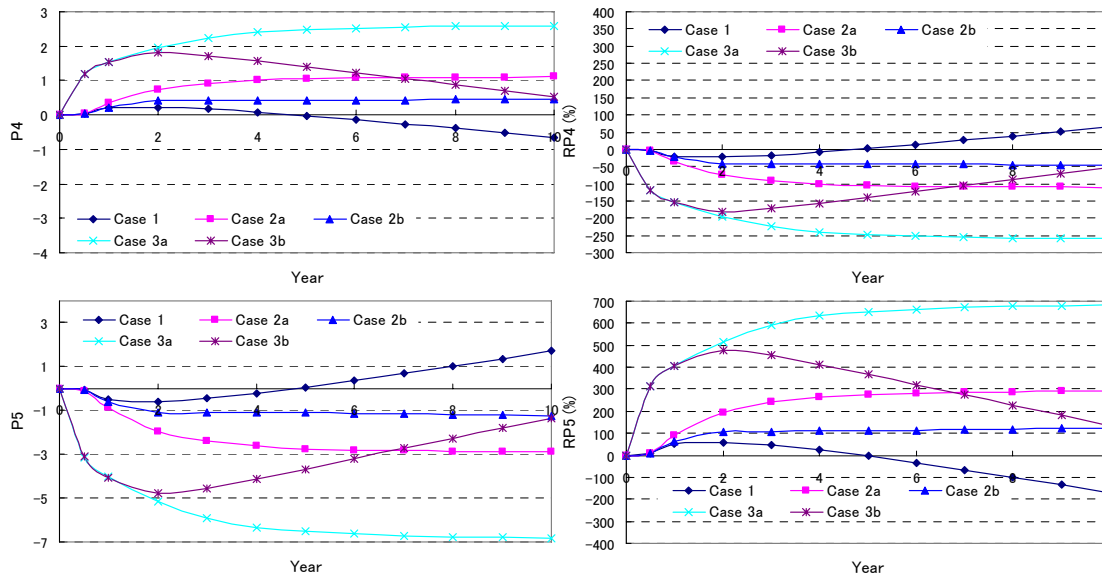

Fig 4.18 Effect of sediment management on the parameters P_4 , and P_5 ; and risk degree of the parameters P_4 , and P_5 at point 18 km from downstream boundary end

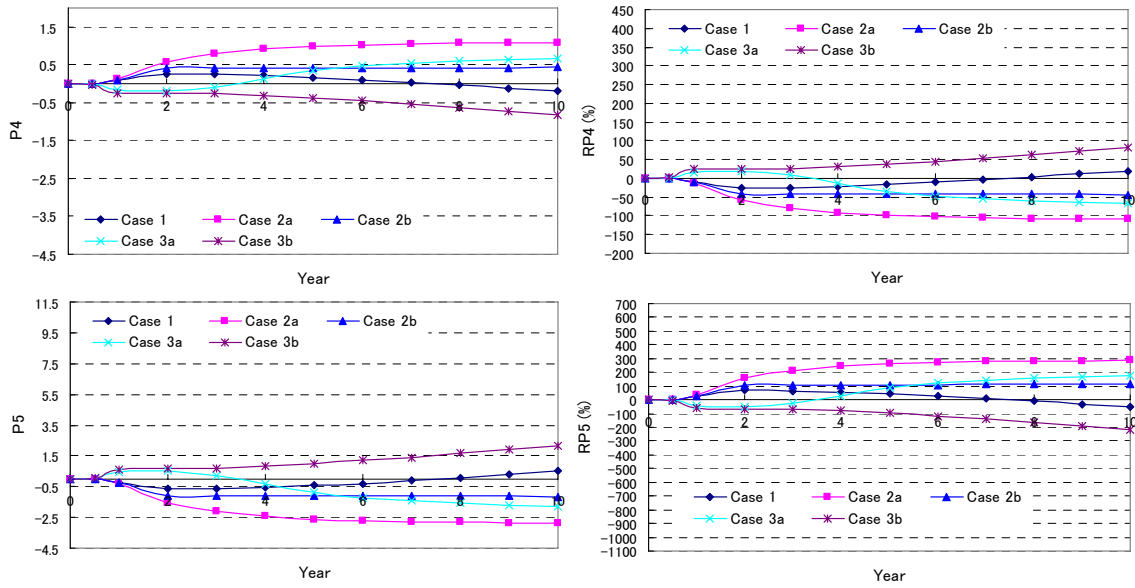

Fig 4.19 Effect of sediment management on the parameters P_4 , and P_5 ; and risk degree of the parameters P_4 , and P_5 at point 14 km from downstream boundary end

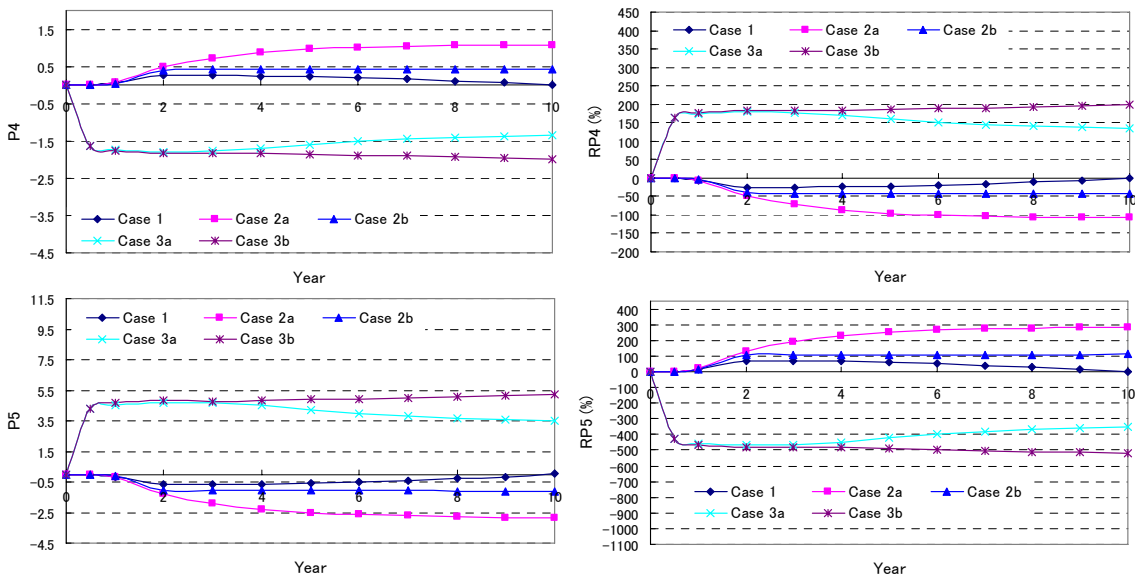

Fig 4.20 Effect of sediment management on the parameters P_4 , and P_5 ; and risk degree of the parameters P_4 , and P_5 at point 11 km from downstream boundary end

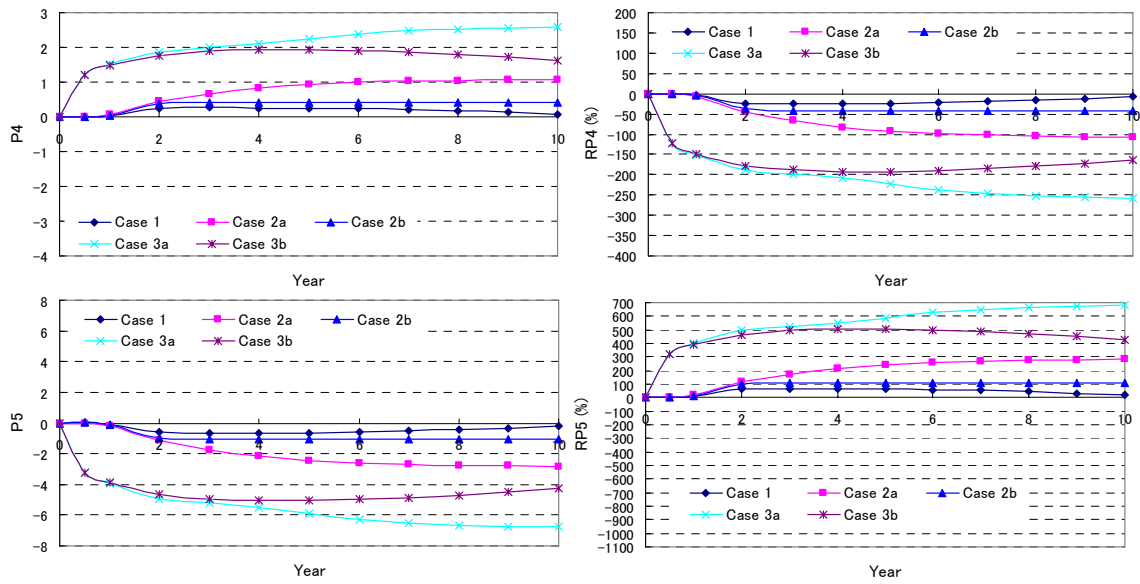

Fig 4.21 Effect of sediment management on the parameters P_4 , and P_5 ; and risk degree of the parameters P_4 , and P_5 at point 9 km from downstream boundary end

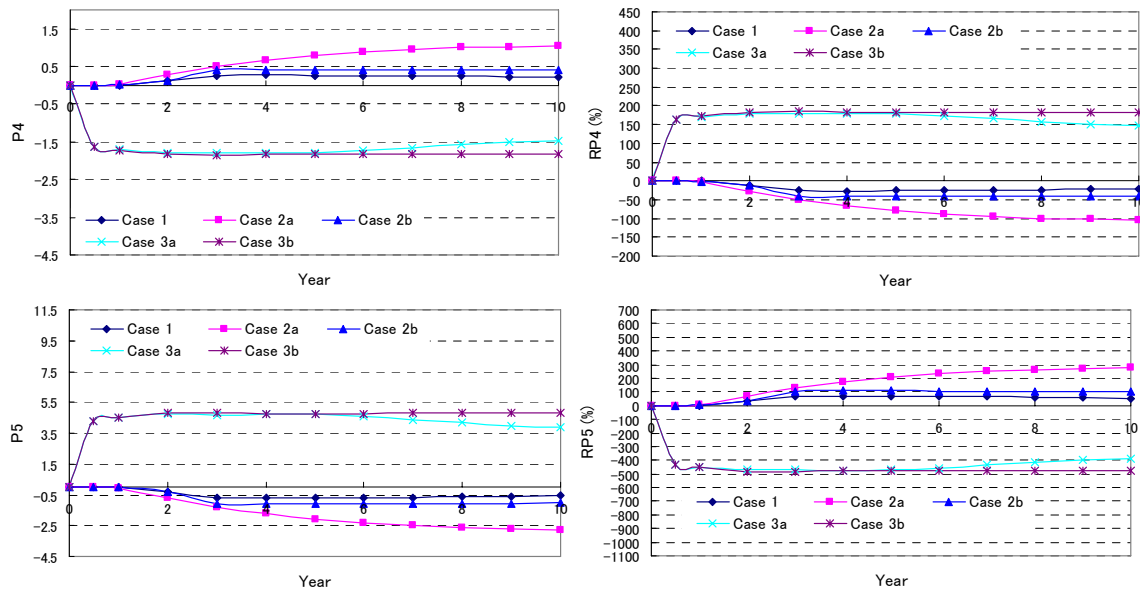

Fig 4.22 Effect of sediment management on the parameters P_4 , and P_5 ; and risk degree of the parameters P_4 , and P_5 at point 2 km from downstream boundary end

(3). Volcanic disaster mitigation

The effect of sediment management on socio-economy also can be evaluated using the benefit associated with disaster mitigation. Although, the method how to calculate the benefits directly is difficult. The sand mining management can be used as a part of the volcanic disaster mitigation against debris flow, so that the cost of sabo facilities can be saved by removing sand from river channels and increasing the capacity of sediment reservoirs. Moreover, controlling the excess sediment discharge by sand mining management can reduce the damage caused by debris flows. It is another benefit from controlling sand mining activity.

4.2.3 Effect of sediment management on environment aspect

Sediment size is the one of the most important factor to affect on habitats for fauna and flora. Hence, the temporal change of the sediment size is discussed here. The influence of sediment management on environmental change is measured by change of the riverbed material. The riverbed material change is indicated by change in the average diameter of the riverbed material. Figure 4.23 shows the riverbed material changes at the observed locations. At the 30 km upstream from the downstream boundary end, change of the riverbed material in the Case 1 is not so big, the mean diameter changes from 1 mm to 2 mm, due to the impact of sediment supply from upstream. In the Cases 2a and 3a, the mean diameter of riverbed material changes from 1 mm to 7 mm. It indicates that an armor layer has been formed at this point. Due to the formed armor layer at the end of the first year, the armor layer protects the riverbed, thus the degradation is not so deep in subsequent years. In the Case 2b, the mean diameter of riverbed material changes fast during the half-first year from 1 mm to 2.25 mm, then the mean diameter does not change in the following years. As a similar condition to the Case 2b, the mean diameter of riverbed in the Case 3b material also changes fast during the first year from 1 mm to 2.22 mm, then the mean diameter does not change in the following years. The result shows that the sediment supply from the upstream can be used to maintain the quality of riverbed material. Without the sediment supply, the riverbed material tends to be coarser. The condition is not suitable for some fish species. At the point 20 km, the mean diameters of riverbed material in most cases

are not change significantly, except in the Case 2a. In the Case 2a, the riverbed material tends to be coarser due to no sediment supply from the upstream. In the Case 3a, the finer sediment will be deposited at this point due to the effect of installed groundsill, so that the mean diameter at this point to be finer than that at the other points. However, the mean diameter in the Case 3a tends to increase. The similar phenomena to the point 20 also take place at the point 11 km and 2 km. At point 18 km upstream from the downstream boundary end, the mean diameters in the Cases 2a and 3a tend to increase. Due to no sediment supply in the both cases, the riverbed material becomes to be coarser. In the Case 3a, the mean diameter increases slightly during half of the first year, then decreases until the first year, after that it tends to increase in the following years. The same condition with the phenomena at point 18 km also takes place at point 14 km and 9 km.

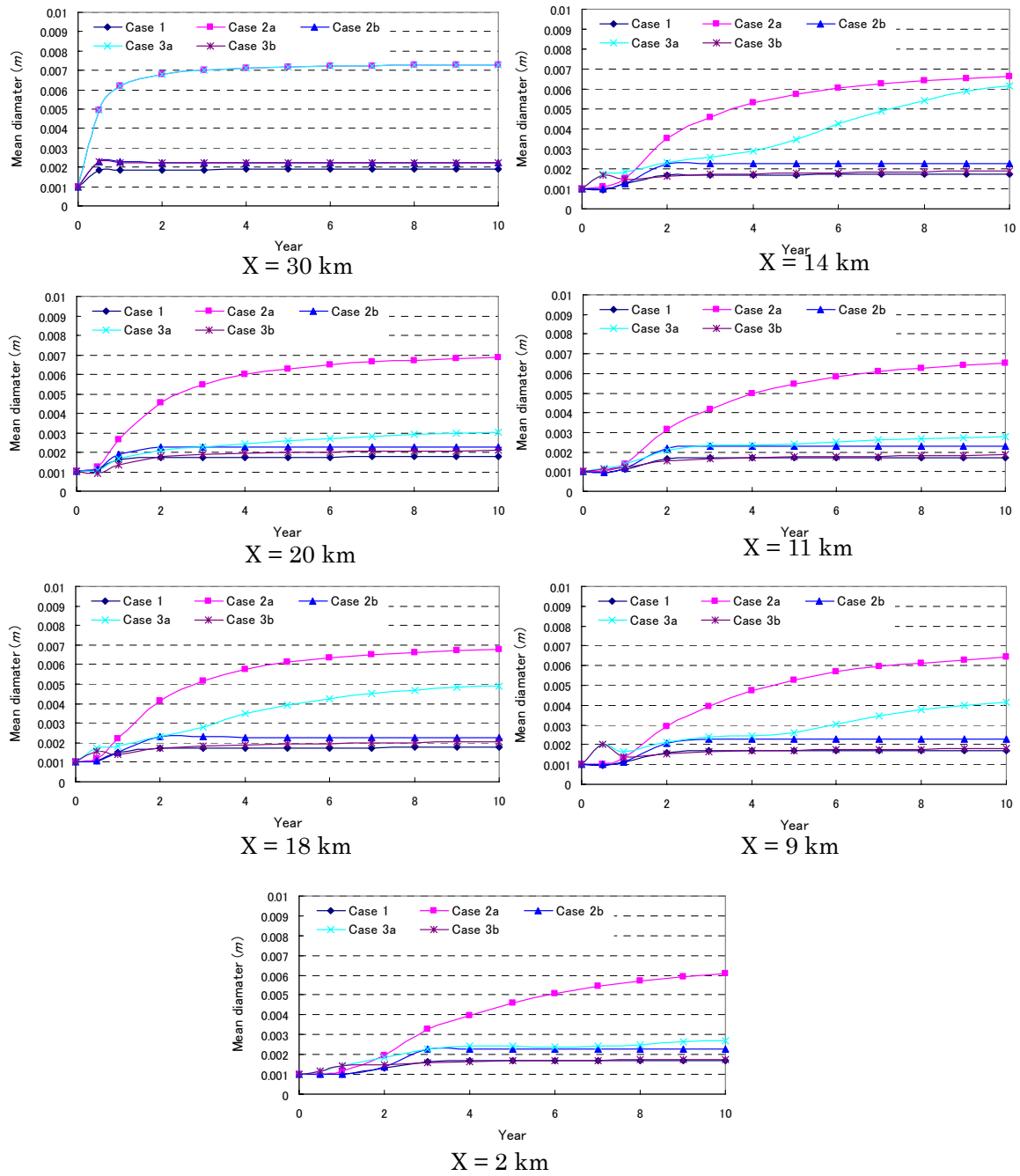

Fig. 4.23 The riverbed material changes at the observed locations

4.2.4 Effect of sediment management on environment, utilization, and safety

Sediment management impacts on the environment, utilization, and safety in all cases at the point 30 km from downstream boundary end are shown in Figures 4.24, 4.25, 4.26, 4.27 and 4.28. Figure 4.24 shows that the sediment management in the Case 1 has a positive impact by the environmental view (d_m), and risk degree of foundation function is smallest (RP_f), but it has the most negative impact for utilization (V_s). The Cases 2a and 3a show good sediment management from utilization point of view, but the both cases cause the biggest negative impact on environment and safety of the foundation of bridge pier. Sediment management as the Cases 2b and 3b have a medium negative impact on environment, safety and utilization. However, Case 3b has the most minimal impact compared with the other cases. Figure 4.25 shows that the sediment management as the Case 1 has a small negative on environment, but it tends to give problem in utilization and the risk degree of pier bridge function. In Cases 2a and 3a, the sediment management will give the positive impact on the utilization and safety of pier function, but the both cases make problem from the environment aspects. Sediment management in the Cases 2b and 3b are good management, and the Case 2b has the minimal impacts. From the bridge function, Case 1a has a biggest negative impacts, followed by Case 3b. The Cases 2a, 2b and 3a have no negative impacts on the bridge function as shown in Figure 4.26. Figure 4.27 indicates that the Case 1 will cause the biggest problem on the risk degree of the sedimentation in irrigation channel. Figure 4.28 shows that the Cases 2a and 3a will cause the biggest problem on the risk degree of water intake function. Based on the results as described above, it is clear that the Case 3b is the most reasonable sediment management.

Figures 4.29 to 4.33 show the effects of sediment management on three aspects at point 20 km. The effects of sediment management on three aspects at point 18 km are shown in Figures 4.34 to 4.38. Figures 4.39 to 4.43 show the effects of sediment management on three aspects at point 14 km. Figures 4.44 to 4.48 show the effects of sediment management on three aspects at point 11 km. Figures 4.49 to 4.53 and 4.54 to 4.58 show the effects of sediment management on three aspects at point 9 km and 2 km, respectively.

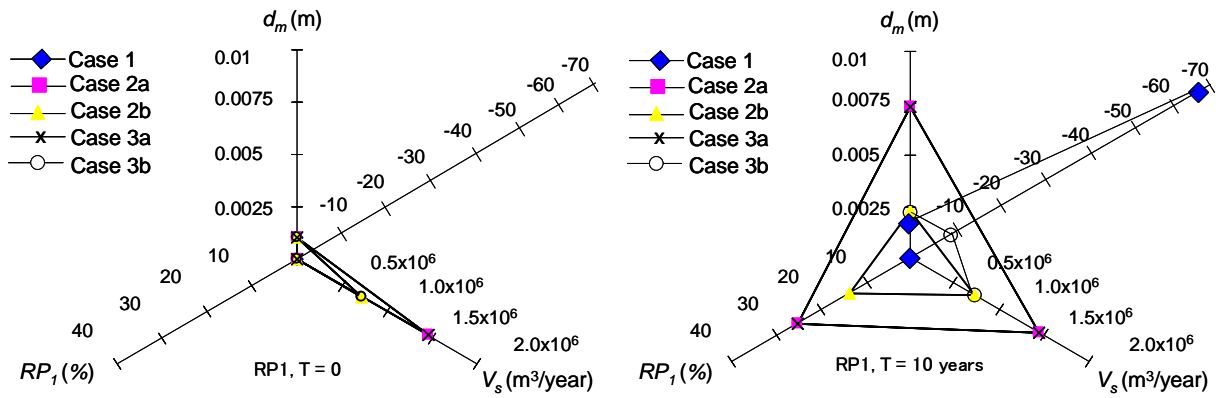

Fig. 4.24 Effect of sediment management on risk degree of bridge foundation function (RP_1), utilization, and environment at point 30 km from downstream boundary end

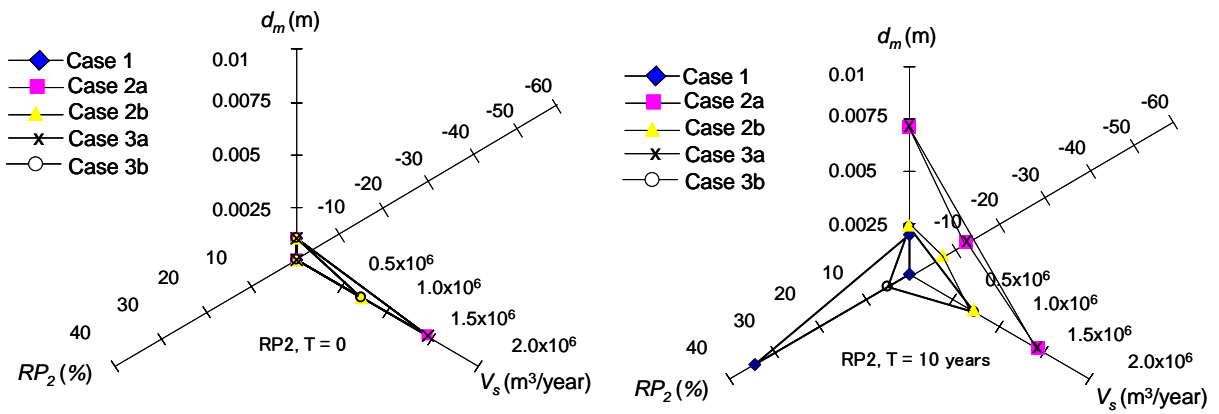

Fig. 4.25 Effect of sediment management on risk degree of pier bridge function (RP_2), utilization, and environment at point 30 km from downstream boundary end

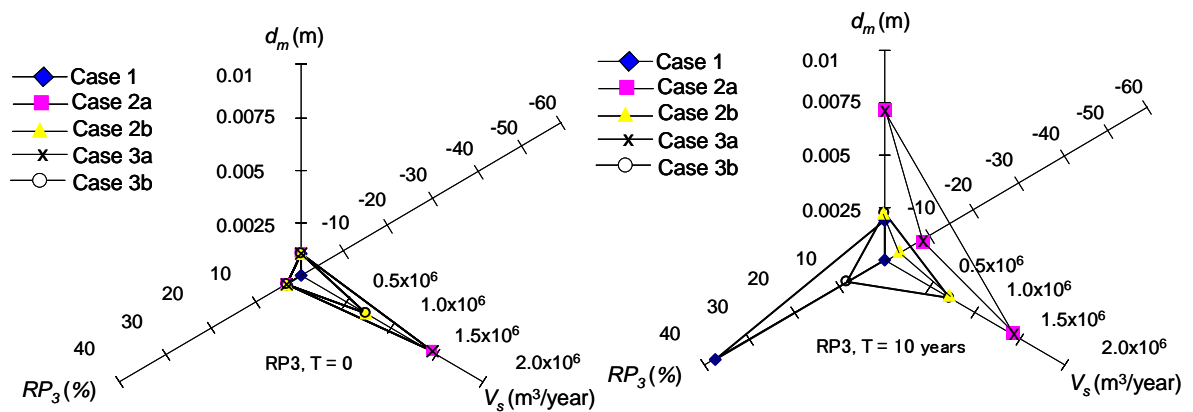

Fig. 4.26 Effect of sediment management on risk degree of bridge function (RP_3), utilization, and environment at point 30 km from downstream boundary end

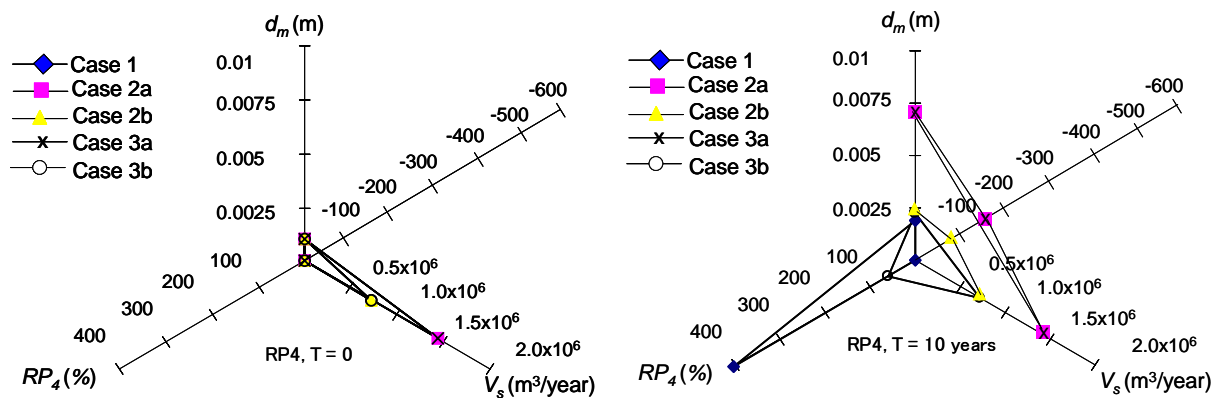

Fig. 4.27 Effect of sediment management on risk degree of sedimentation (RP_4), utilization, and environment at point 30 km from downstream boundary end

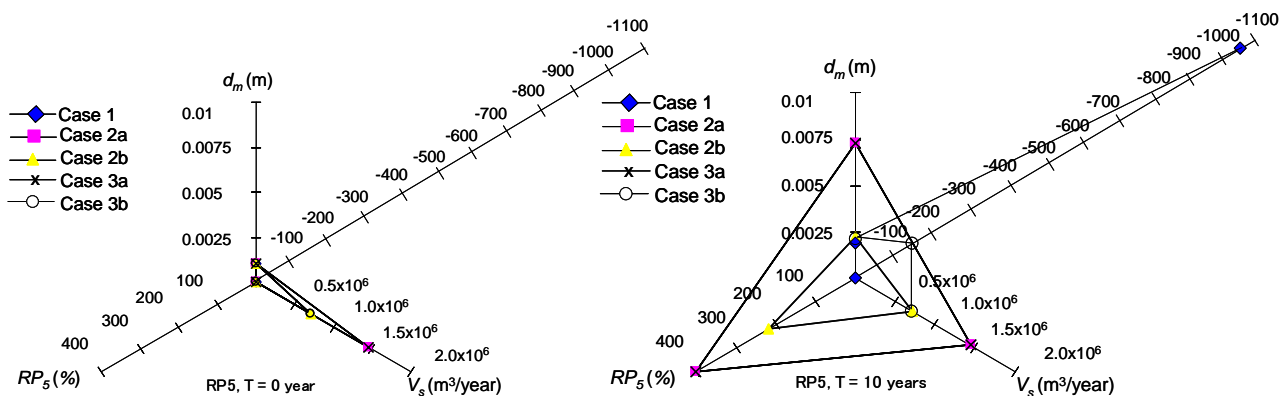

Fig. 4.28 Effect of sediment management on risk degree of water intake function (RP_5), utilization, and environment at point 30 km from downstream boundary end

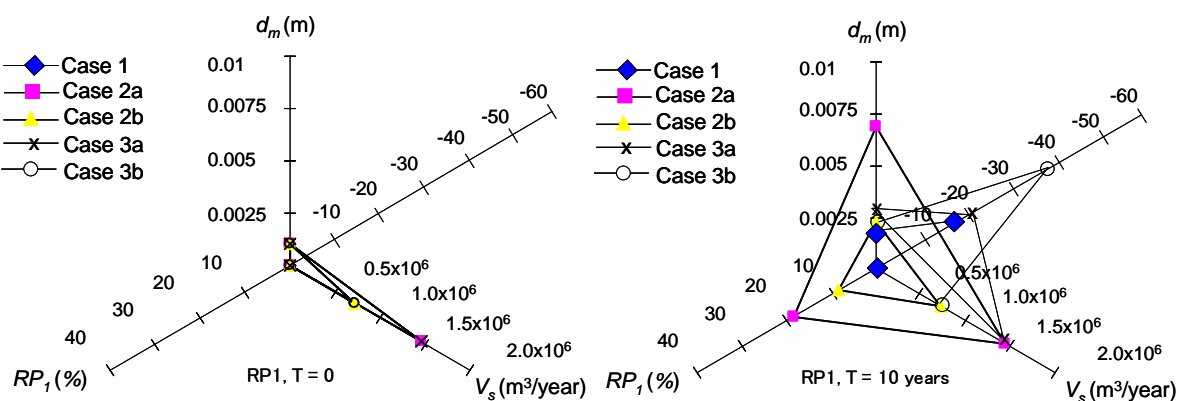

Fig. 4.29 Effect of sediment management on risk degree of foundation bridge function (RP_1), utilization, and environment at point 20 km from downstream boundary end

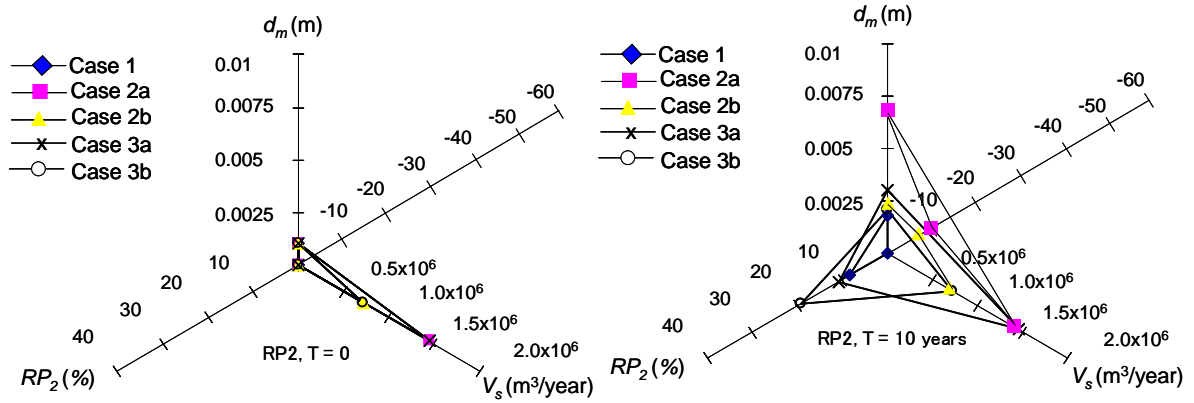

Fig. 4.30 Effect of sediment management on risk degree of pier bridge function (RP_2), utilization, and environment at point 20 km from downstream boundary end

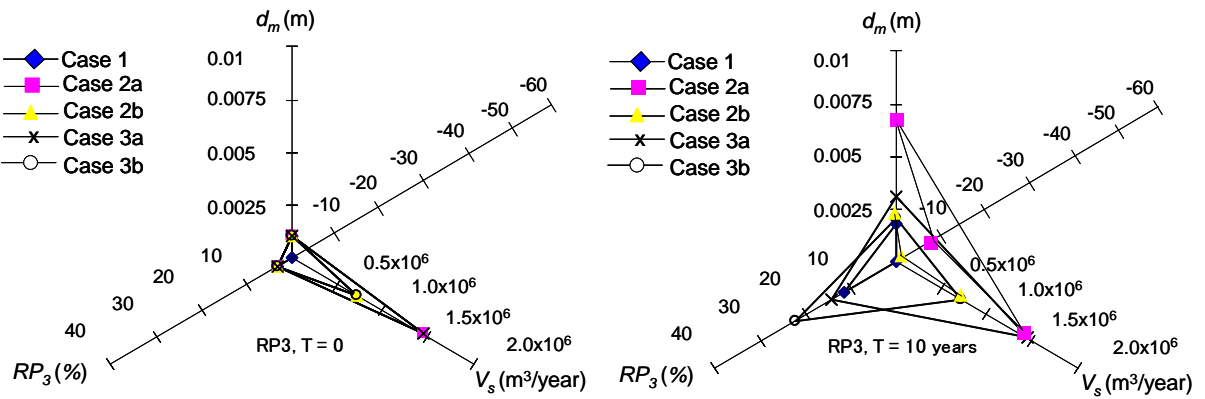

Fig. 4.31 Effect of sediment management on risk degree of bridge function (RP_3), utilization, and environment at point 20 km from downstream boundary end

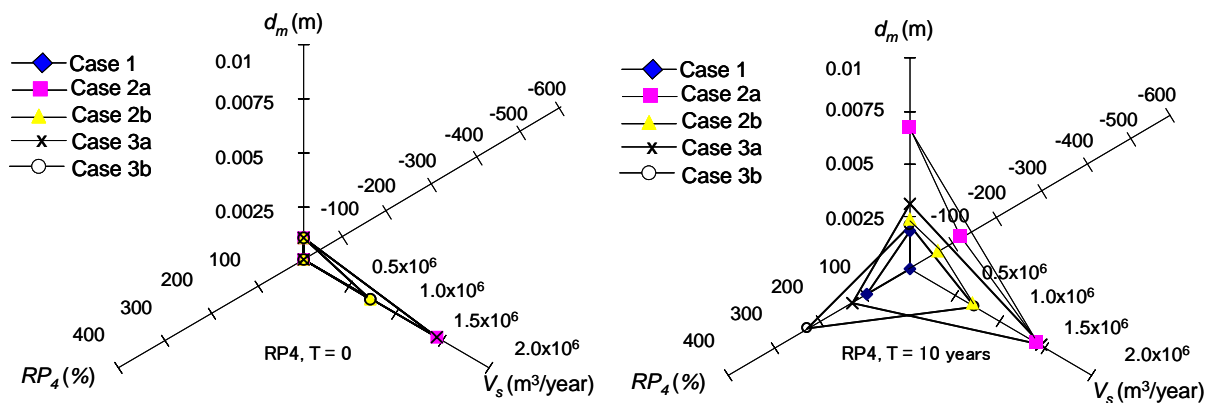

Fig. 4.32 Effect of sediment management on risk degree of sedimentation (RP_4), utilization, and environment at point 20 km from downstream boundary end

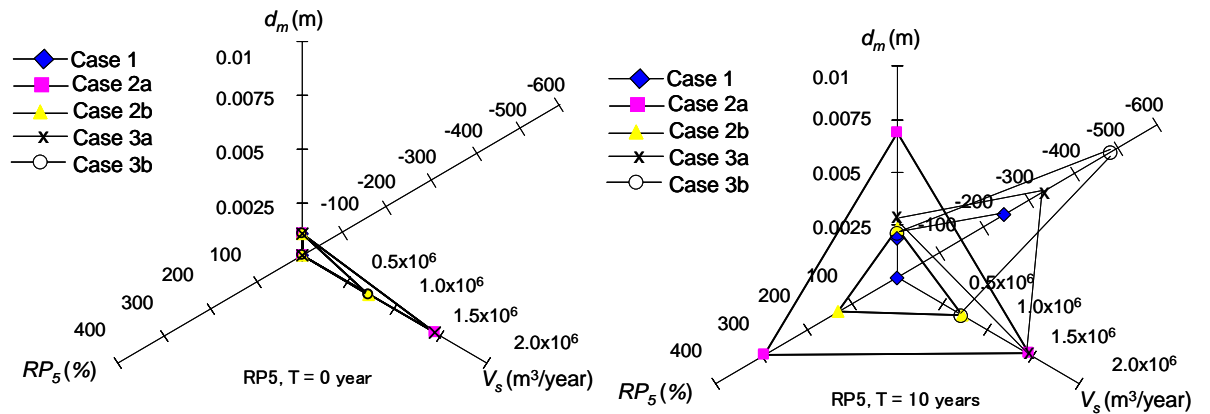

Fig. 4.33 Effect of sediment management on risk degree of water intake function (RP_5), utilization, and environment at point 20 km from downstream boundary end

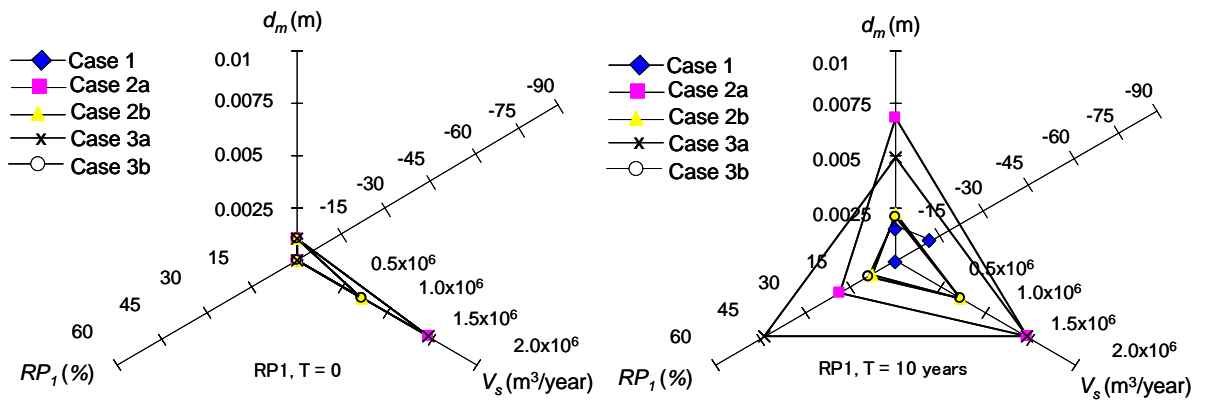

Fig. 4.34 Effect of sediment management on risk degree of foundation bridge function (RP_1), utilization, and environment at point 18 km from downstream boundary end

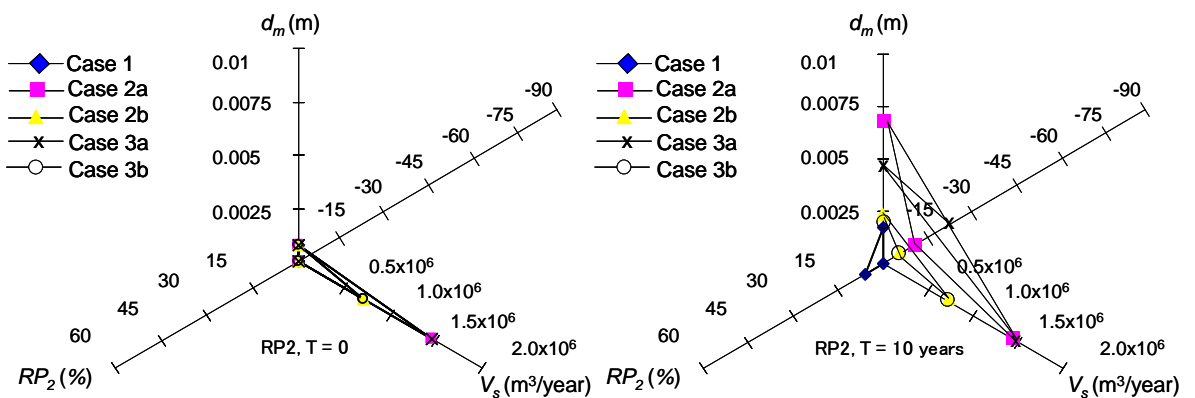

Fig. 4.35 Effect of sediment management on risk degree of pier bridge function (RP_2), utilization, and environment at point 18 km from downstream boundary end

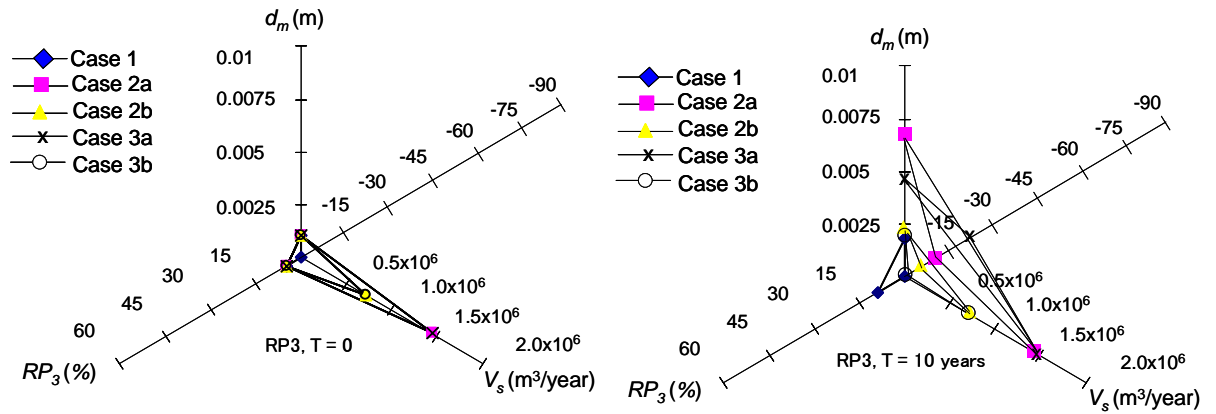

Fig. 4.36 Effect of sediment management on risk degree of bridge function (RP_3), utilization, and environment at point 18 km from downstream boundary end

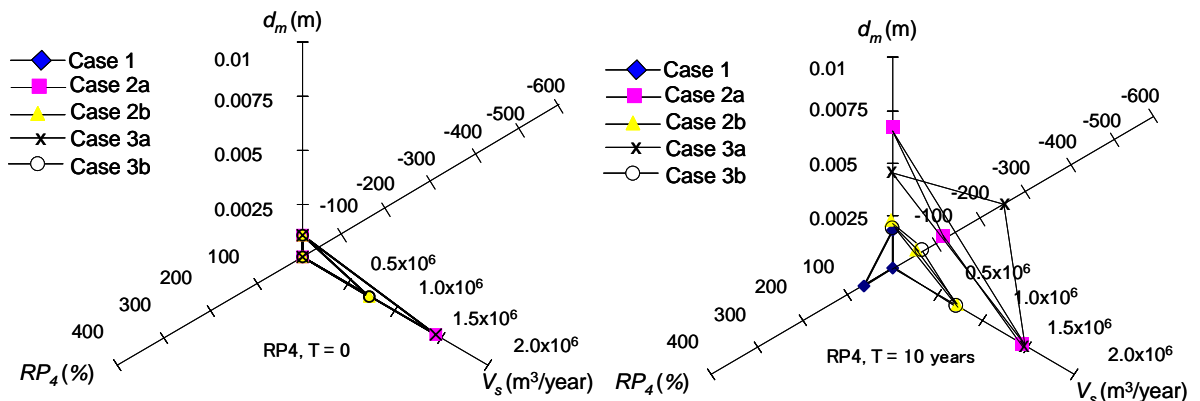

Fig. 4.37 Effect of sediment management on risk degree of sedimentation (RP_4), utilization, and environment at point 18 km upstream from downstream boundary end

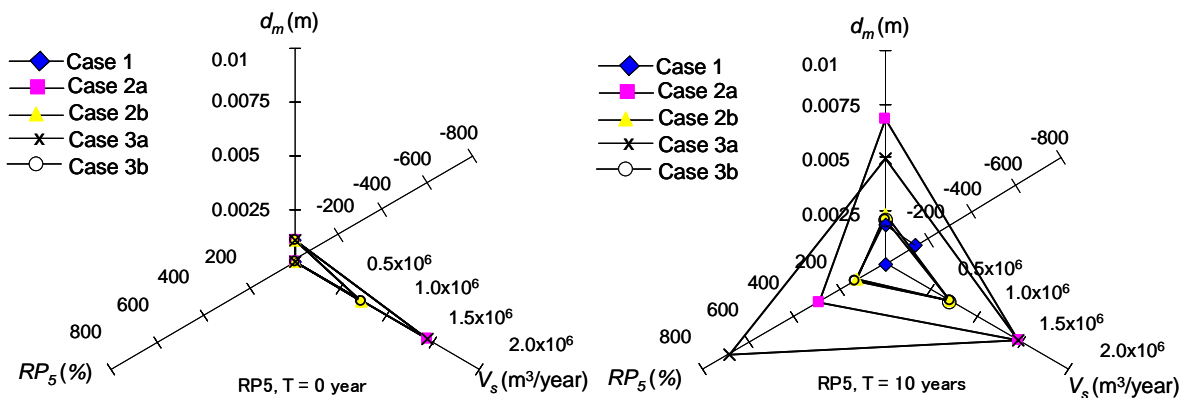

Fig. 4.38 Effect of sediment management on risk degree of water intake function (RP_5), utilization, and environment at point 18 km from downstream boundary end

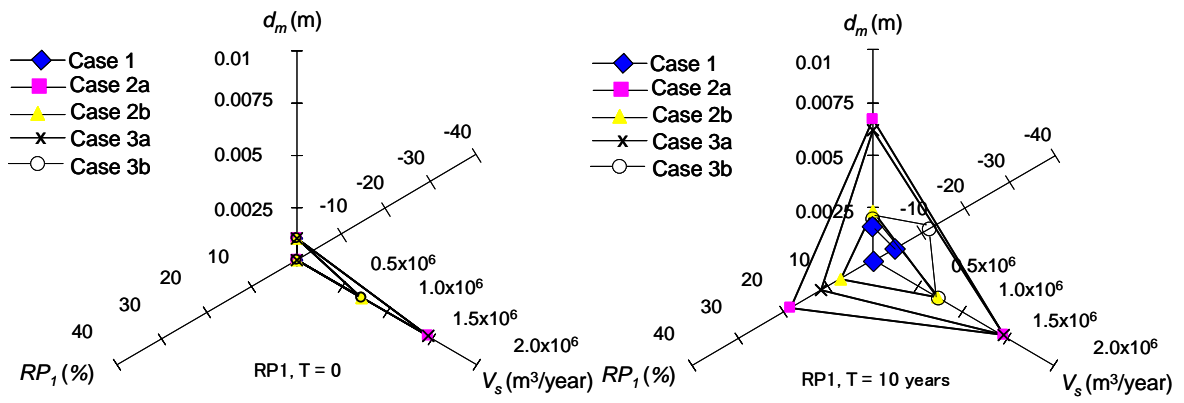

Fig. 4.39 Effect of sediment management on risk degree of foundation bridge function (RP_1), utilization, and environment at point 14 km from downstream boundary end

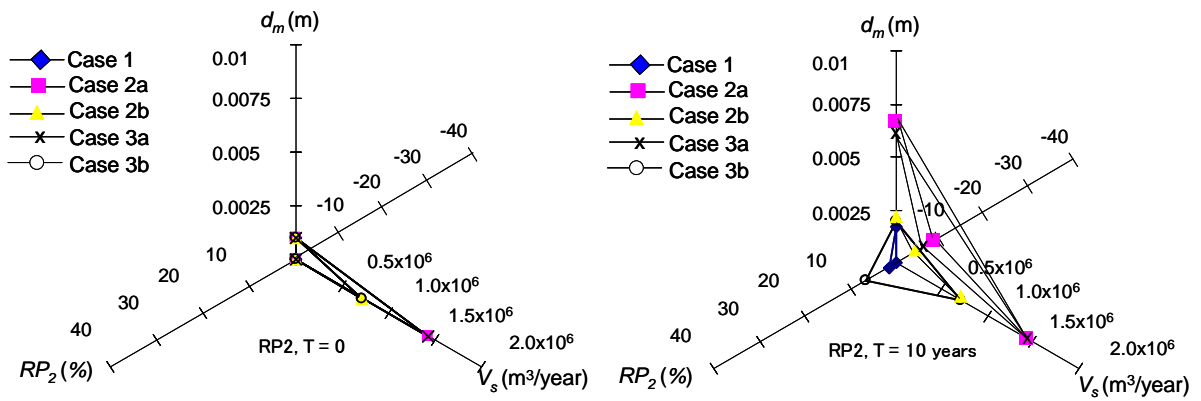

Fig. 4.40 Effect of sediment management on risk degree of pier bridge function (RP_2), utilization, and environment at point 14 km from downstream boundary end

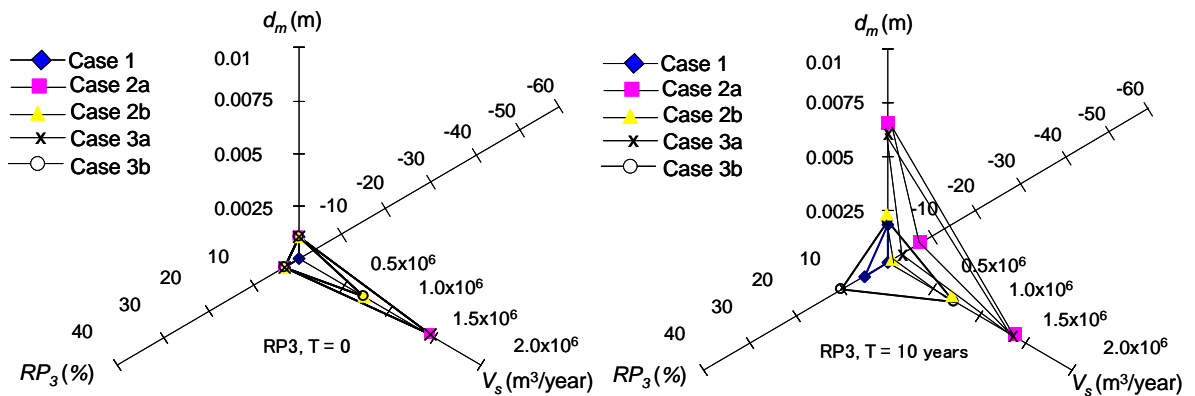

Fig. 4.41 Effect of sediment management on risk degree of bridge function (RP_3), utilization, and environment at point 14 km from downstream boundary end

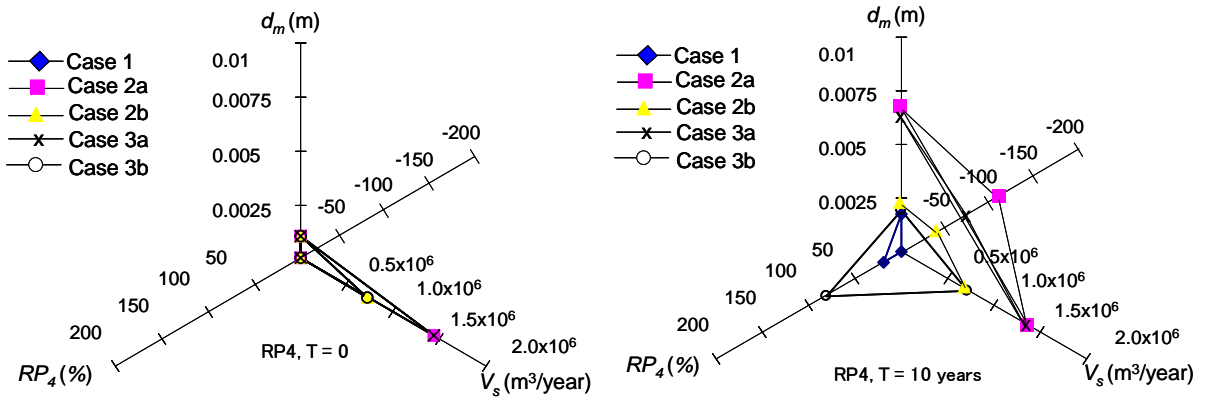

Fig. 4.42 Effect of sediment management on risk degree of sedimentation (RP_4), utilization, and environment at point 14 km from downstream boundary end

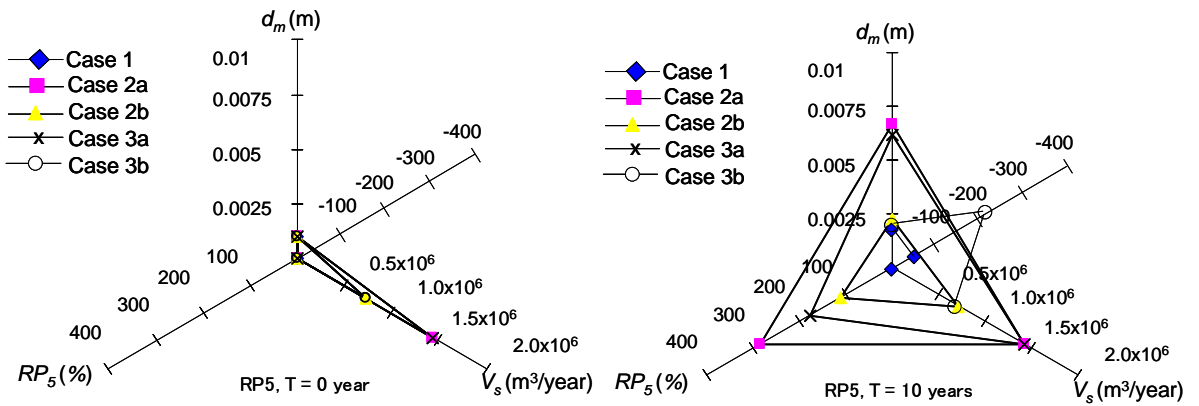

Fig. 4.43 Effect of sediment management on risk degree of water intake function (RP_5), utilization, and environment at point 14 km from downstream boundary end

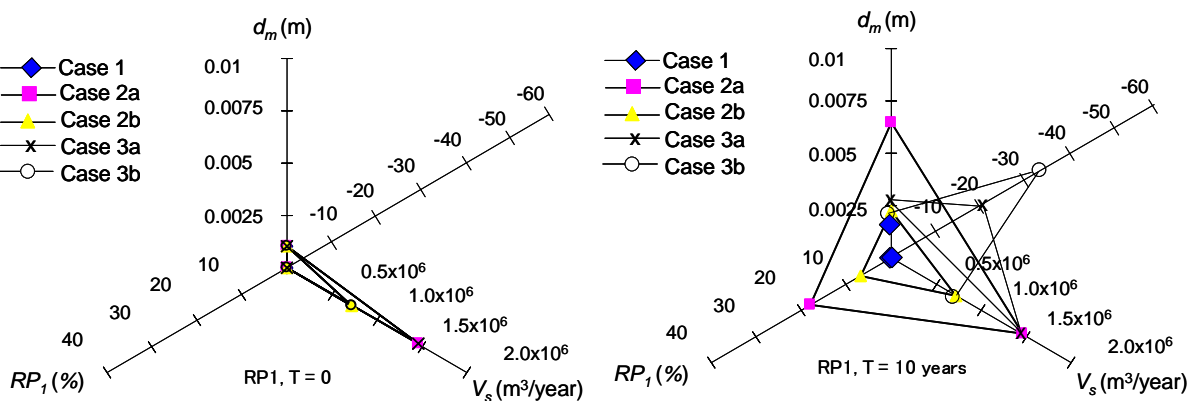

Fig. 4.44 Effect of sediment management on risk degree of foundation bridge function (RP_1), utilization, and environment at point 11 km from downstream boundary end

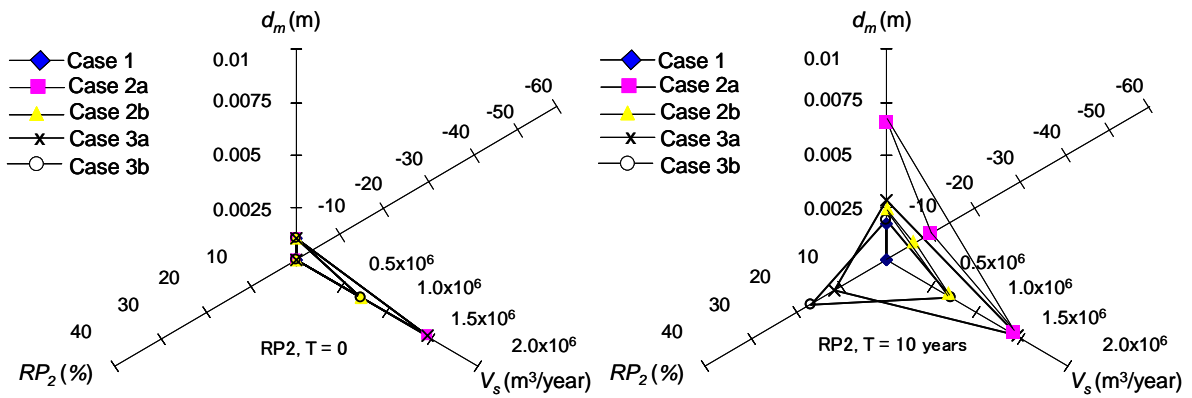

Fig. 4.45 Effect of sediment management on risk degree of pier bridge function (RP_2), utilization, and environment at point 11 km from downstream boundary end

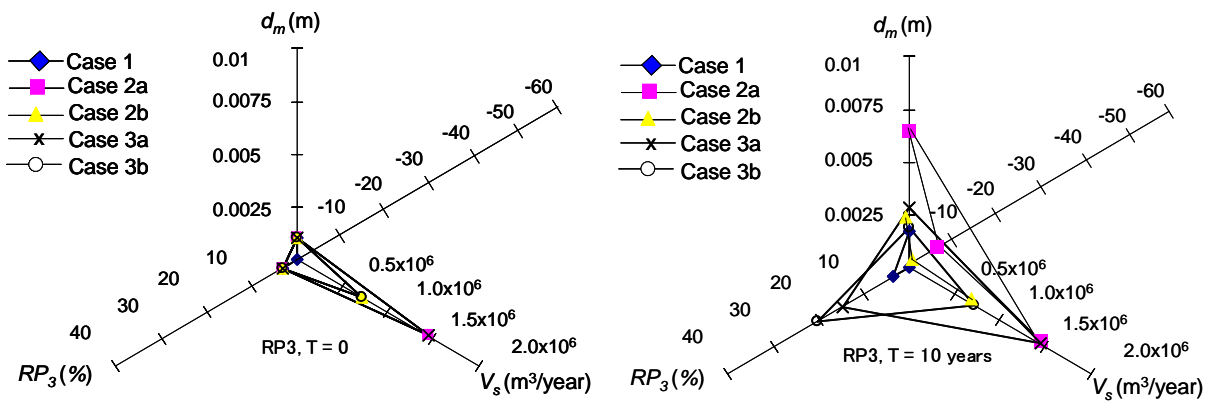

Fig. 4.46 Effect of sediment management on risk degree of bridge function (RP_3), utilization, and environment at point 11km from downstream boundary end

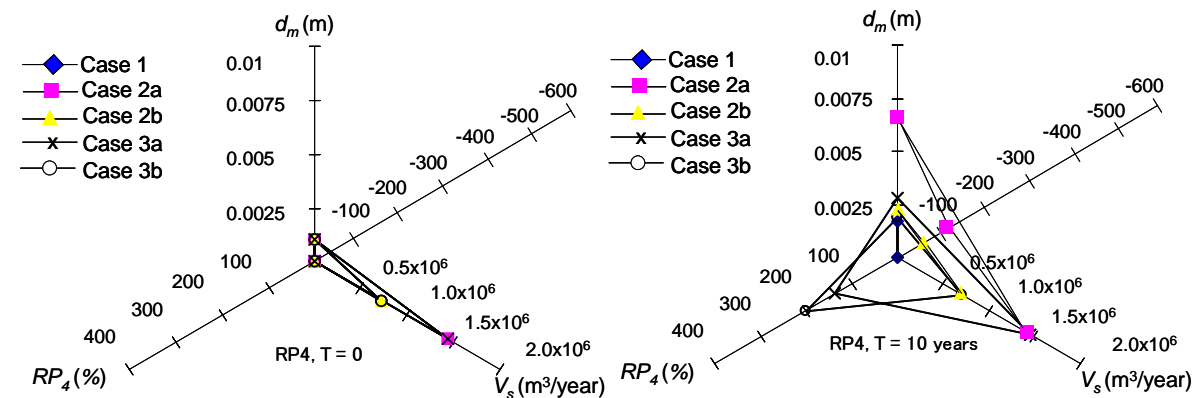

Fig. 4.47 Effect of sediment management on risk degree of sedimentation (RP_4), utilization, and environment at point 11 km from downstream boundary end

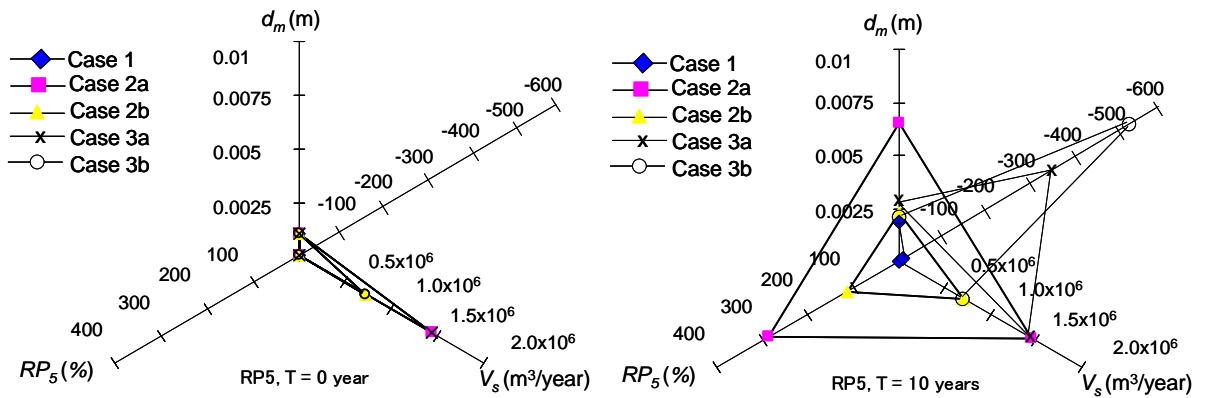

Fig. 4.48 Effect of sediment management on risk degree of water intake function (RP_5), utilization, and environment at point 11 km from downstream boundary end

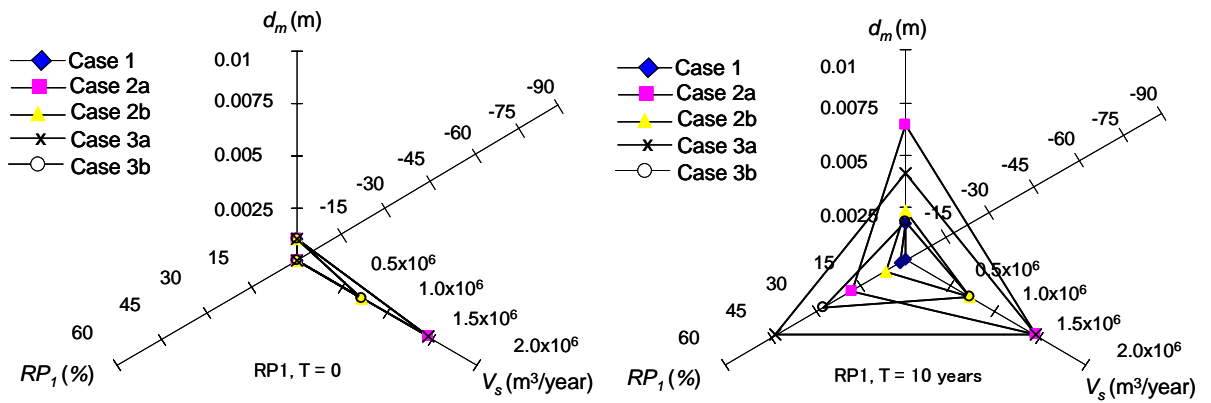

Fig. 4.49 Effect of sediment management on risk degree of foundation bridge function (RP_1), utilization, and environment at point 9 km from downstream boundary end

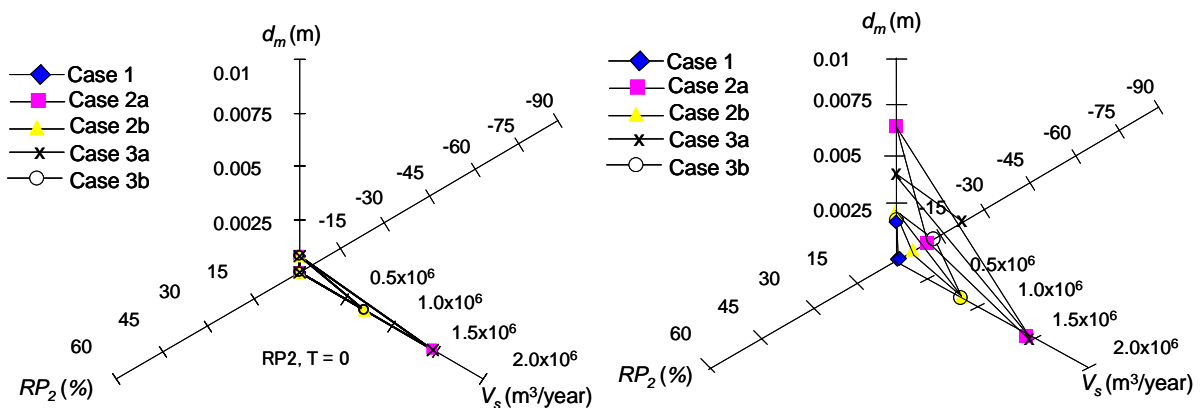

Fig. 4.50 Effect of sediment management on risk degree of pier bridge function (RP_2), utilization, and environment at point 9 km from downstream boundary end

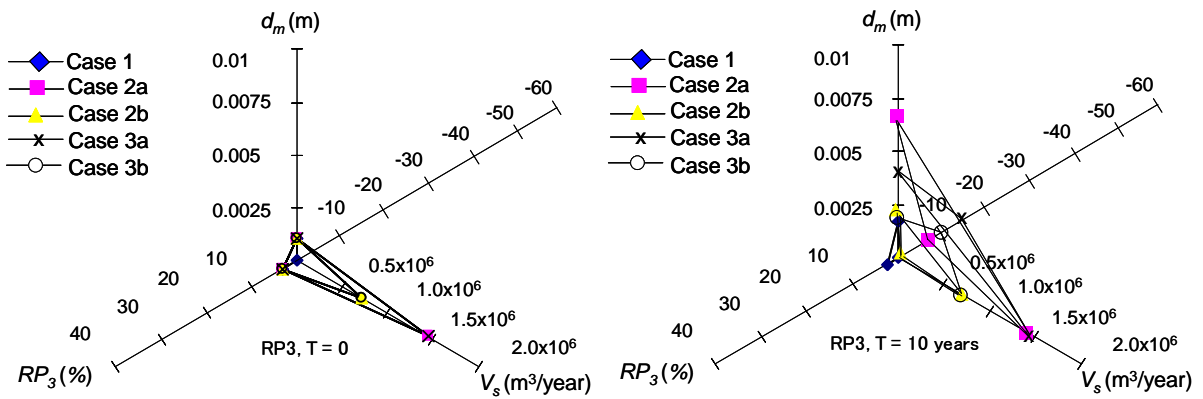

Fig. 4.51 Effect of sediment management on risk degree of bridge function (RP_3), utilization, and environment at point 9km from downstream boundary end

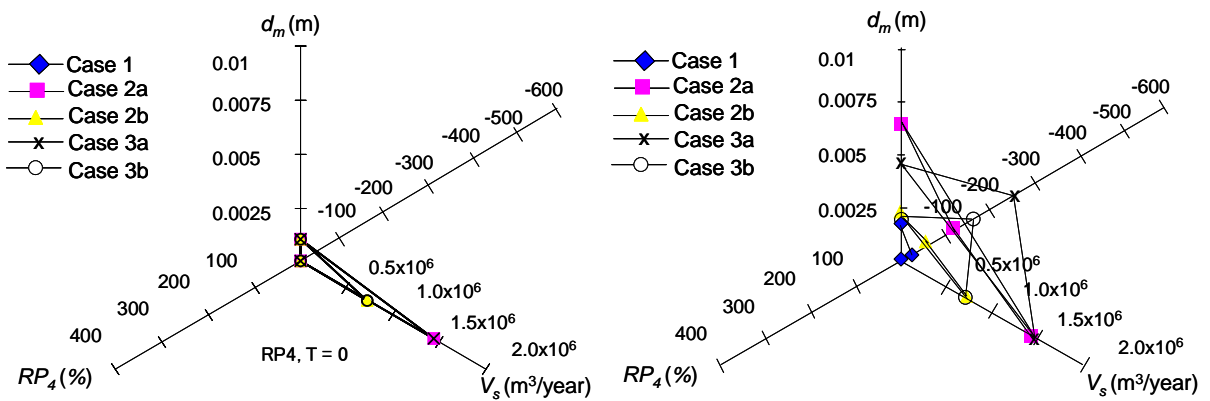

Fig. 4.52 Effect of sediment management on risk degree of sedimentation (RP_4), utilization, and environment at point 9 km from downstream boundary end

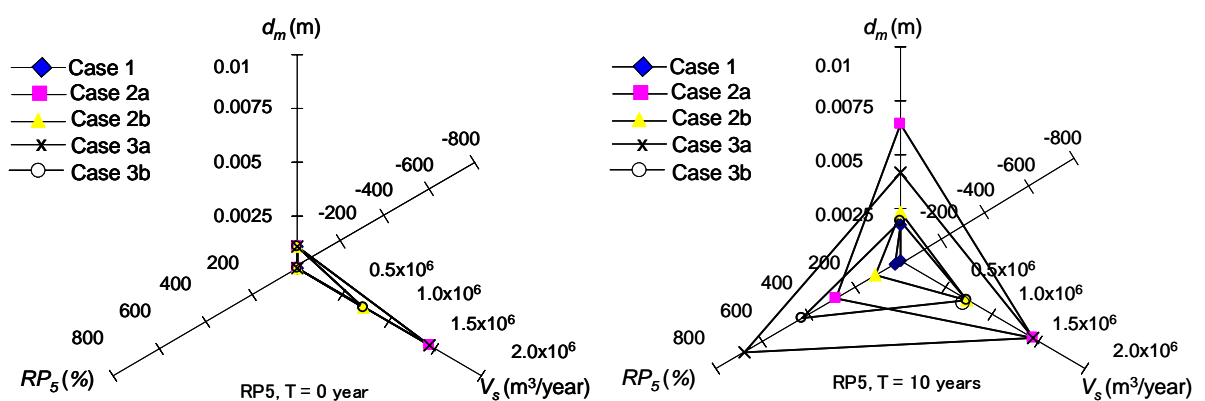

Fig. 4.53 Effect of sediment management on risk degree of water intake function (RP_5), utilization, and environment at point 9 km from downstream boundary end

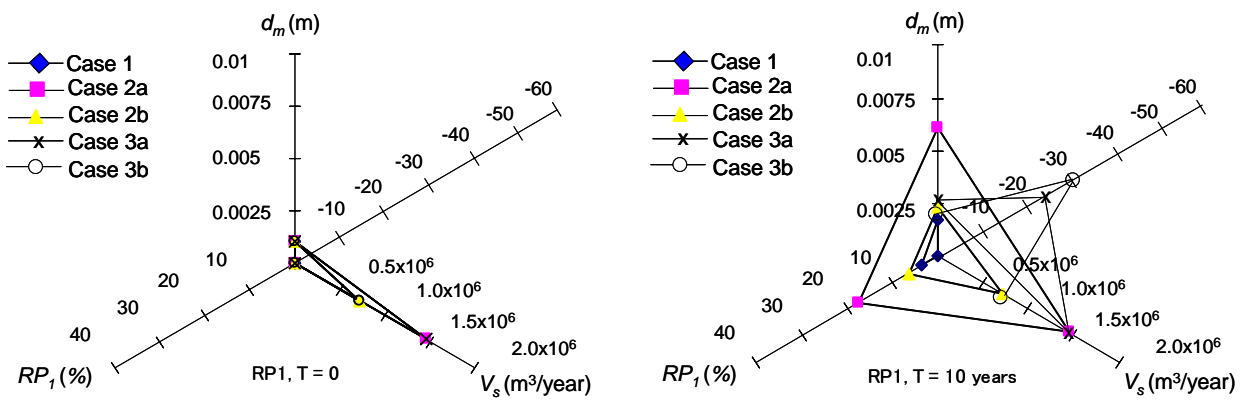

Fig. 4.54 Effect of sediment management on risk degree of foundation bridge function (RP_1), utilization, and environment at point 2 km from downstream boundary end

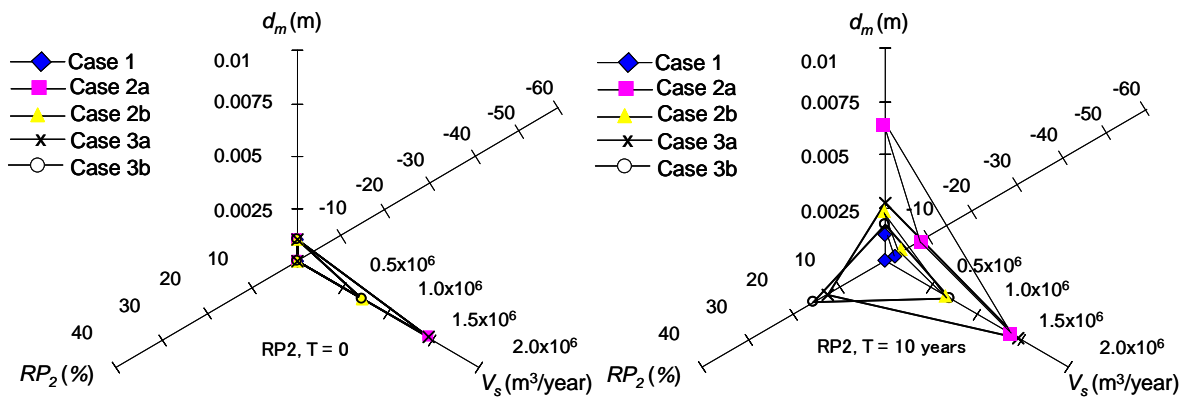

Fig. 4.55 Effect of sediment management on risk degree of pier bridge function (RP_2), utilization, and environment at point 2 km from downstream boundary end

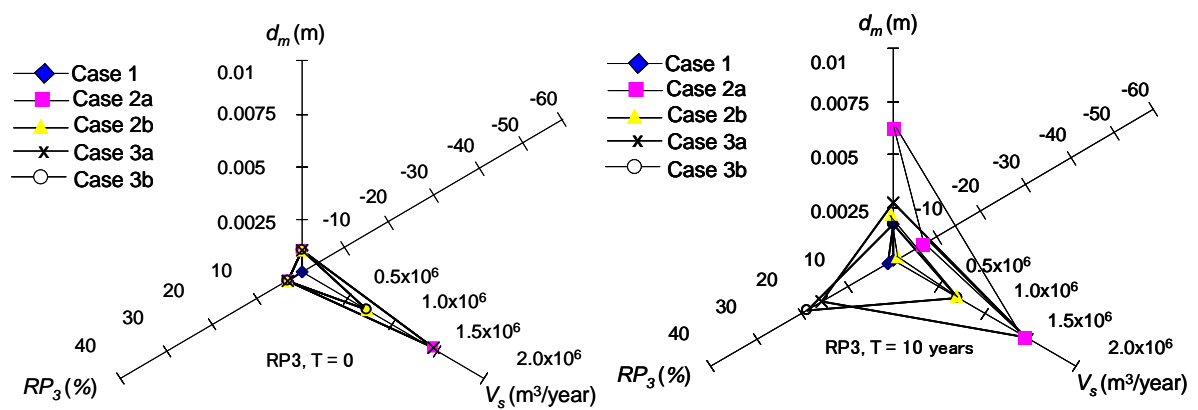

Fig. 4.56 Effect of sediment management on risk degree of bridge function (RP_3), utilization, and environment at point 2km from downstream boundary end

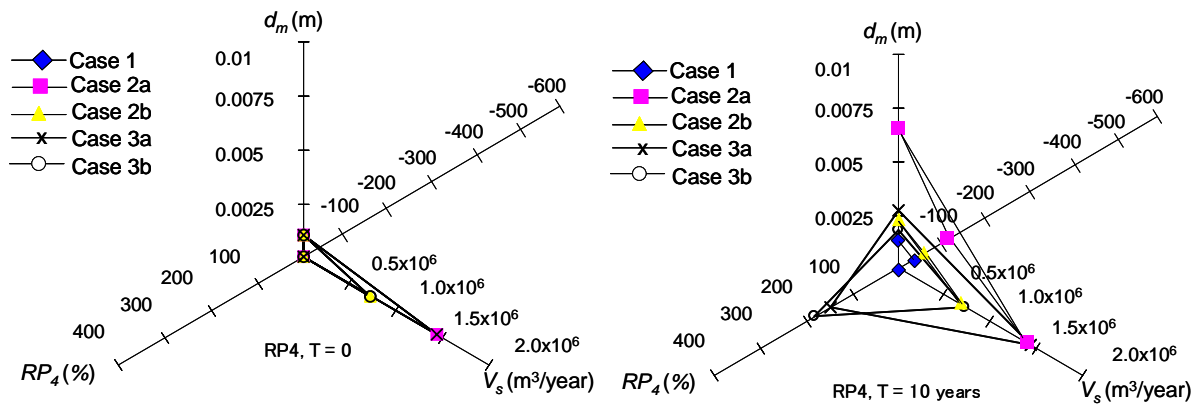

Fig. 4.57 Effect of sediment management on risk degree of sedimentation (RP_4), utilization, and environment at point 2km from downstream boundary end

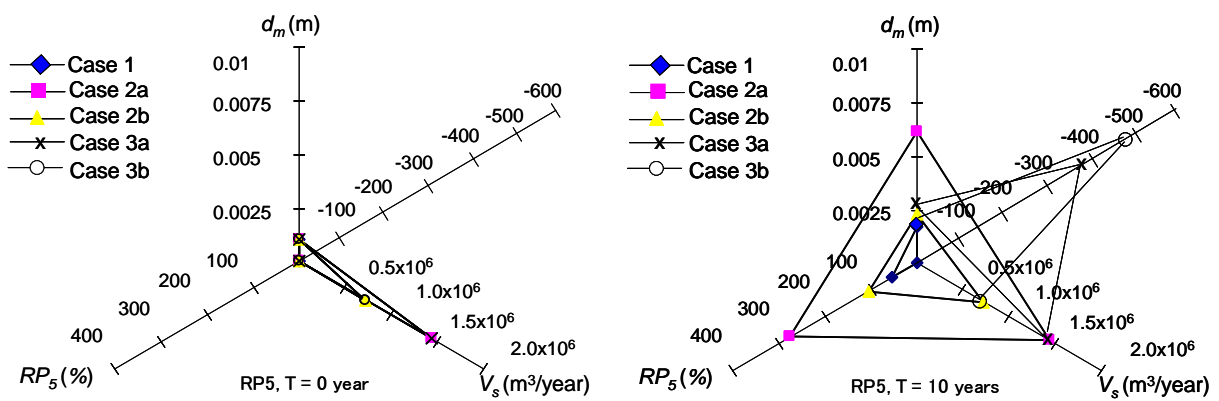

Fig. 4.58 Effect of sediment management on risk degree of water intake function (RP_5), utilization, and environment at point 2km from downstream boundary end

4.2.5 Present and preferable conditions

Sub section 4.2.3 has described a method for evaluating the effect of sediment management on environment, utilization and safety aspects. In Mount Merapi case, the previous sediment management and sediment disaster have influenced on environment, utilization and safety conditions. Present conditions of environment, utilization and safety aspects in Mount Merapi basin are shown in Figure 4.59 (a). Figure 4.59 (b) shows the preferable condition of three aspects by sediment management in future.

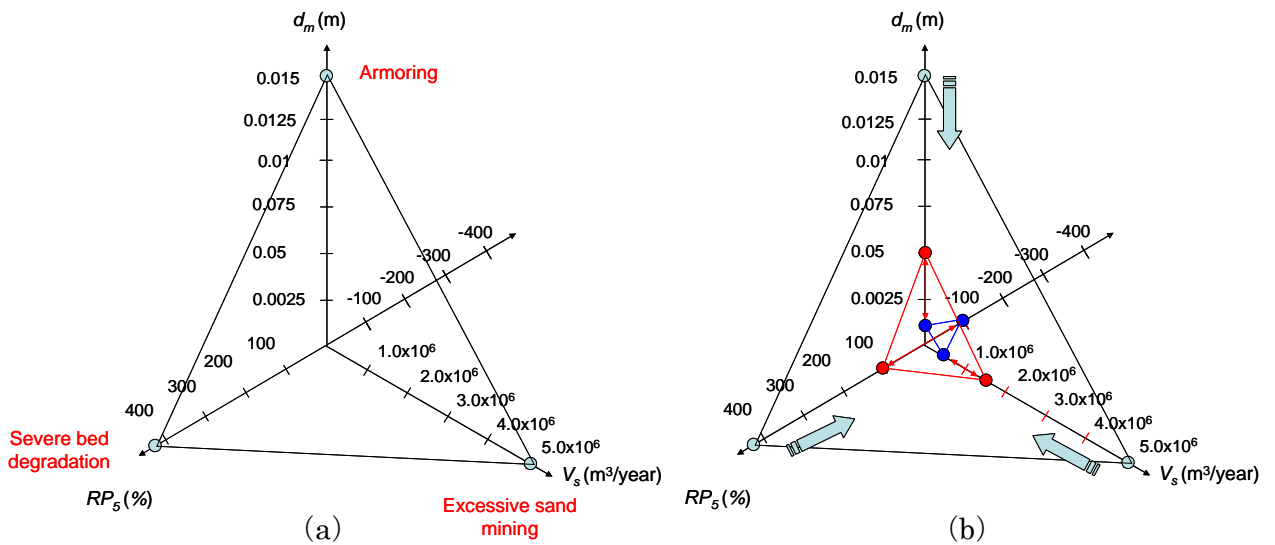

Fig. 4.59 (a) Present conditions of environment, utilization and safety aspects. (b). Preferable conditions of the three aspects by sediment management

Figure 4.59 (a) shows that the problem on river environment is armoring on surface bed material due to no sediment supply from upstream caused by excessive sand mining. The excessive sand mining gives the good advantages from utilization point of view, but on the other hand, it makes the basin situation worse. In addition, severe bed degradation takes places in the downstream of Progo River by the excessive sand mining. This condition would threat the function of river structures, especially irrigation intake structures. The problem on the three aspects should be overcome for achieving a good basin condition in future. The new sediment management is expected to be able to control the excessive sand mining to recover river morphology and keep riverbed elevation. Criteria for deciding the maximum and minimum values of mean diameter of riverbed material are needed, so that the available range of mean diameter could be determined. In this study, author does not determine the range of mean diameter of bed riverbed material that is suitable for fish habitats, because of the lack of the information on the relationship between sediment size and fish habitats. The collaboration study with social, economical and environmental researcher is necessary in future. From utilization point of view, the maximum value of sand mining is equal to 1.44 million $m^3/year$, but the minimum value is not determined in this study. For risk degree of the function of river structures, the minimum and maximum values are 100% and -100%, respectively. In the range between -100% and 100%, the river structures can work well.

4.3 Bed Porosity Variation Model

A sediment production in a basin river system is not constant, because it depends on the triggering factors. In a volcanic basin, especially in a volcanic active area, the sediment production depends on the volcanic activities. Volume of the sediment production closely related to the eruptions. The sediment production will give the problems on the environmental and societal aspects, if amount of sediment production is too little or too much. Under the both conditions, sediment is needed to be managed. Sediment is managed for a variety of reasons, safety, river environment, and utilization. For example, countermeasure to excess of sediment production from Mount Merapi in Indonesia, people make some efforts by construction of the sediment control facilities in the upper area. Consequently, the sediment will be trapped. On the other hand, the transported sediment of a river system on a basin is continuous. Changes in quantitative or qualitative of the sediment in the upper reach of the basin can affect on the characteristic of sediment at many kilometers downstream.

The sediment management in rivers has a long history, but it has still tended to deal with quantitative issue, usually associated with excessive or deficit amounts of sediment (Owens, 2005). The link between sediment and ecology of aquatic systems has become important in recent years. Sediment plays an important role for the river basin and offers a variety of habitats for many aquatic species. The specific role of sediment in aquatic ecosystems is porosity (Mancini *et. al.*, 2008). It indicates that the study of qualitative sediment, such as porosity and grain size change by natural condition or human activity, is important in the recent decade. The study on change of qualitative sediment, due to the human activity or natural condition in this research is conducted by experimental and numerical studies.

4.3.1 Experimental study

A flume experiment as shown in Figure 4.60 is conducted to observe the processes of porosity and grain size changes. The experiment is performed in a flume with a width of 0.40 m, a depth of 0.40 m and a working length of 7.0 m (see Figure 4.61 (a)). The flume walls are made of clear acrylic. The slope of the flume is adjusted to 0.009. Water is circulated and the water discharge is attempted nearly

constant during the experiment. A continuous sediment mixture is originally placed in the working section and scraped flat. The thickness of the sediment layer over the channel bottom is 6.0 cm. The original bed material is composed of fractions from 0.125 mm to 11.2 mm and the mean diameter, d_m , is 2.8 mm. The grain size distribution is shown in Figure 4.61 (b).

The experiment consists of three runs, Run 1, Run 2 and Run 3. In Run 1, no sediment is supplied and the run is continued until the flow brings little sediment. Cumulative time steps for Run 1 are 15, 30, 60, 120, 180, 240, 300, 360 and 420 minutes. Run 1 is followed by Run 2 and the condition of channel bed in the end of Run 1 is used as the initial condition of Run 2. In Run 2, grain size of sediment that is the same as the original bed material in Run 1 is fed constantly from the upstream end of the flume by a conveyor belt as shown in Photo 4.2. Run 2 is continued until sediment discharge relatively constant and elevation of the channel

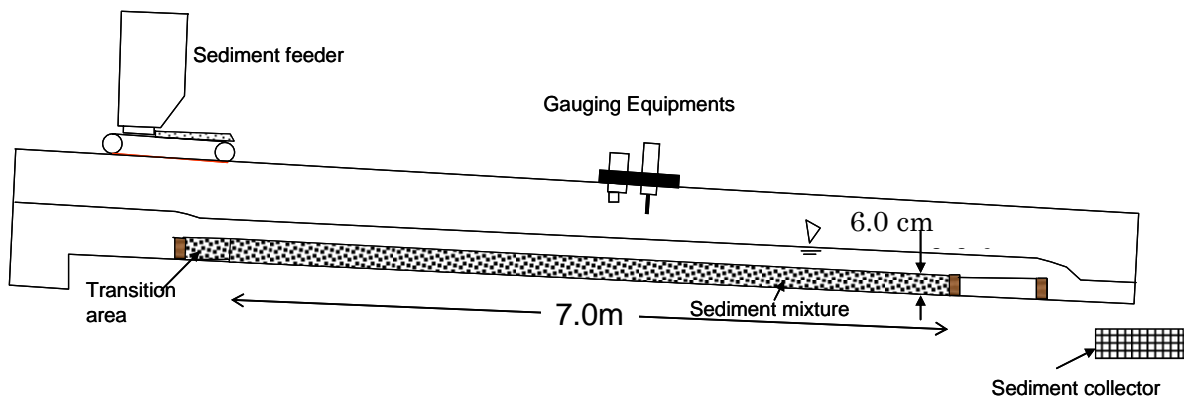

Fig. 4.60 Sketch of the experimental flume test

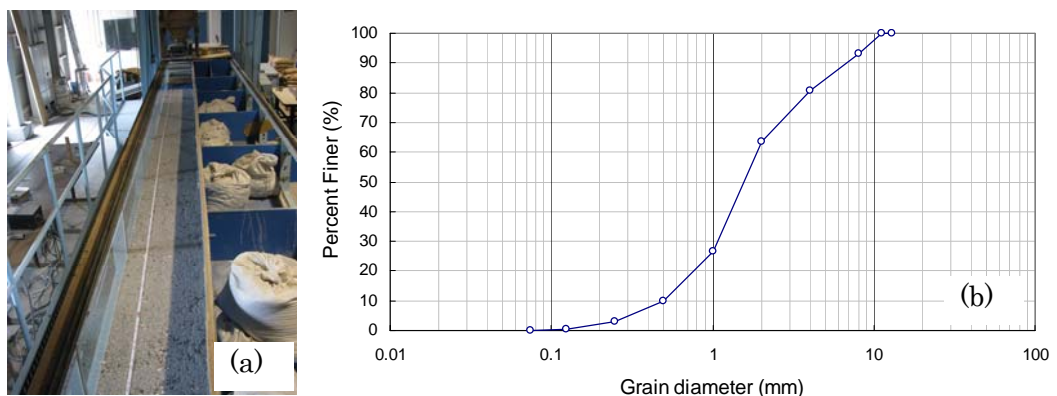

Fig. 4.61 (a) The flume and (b) grain size distribution used in the experiment

bed is the same as the initial channel bed in Run 1. Cumulative time steps for Run 2 are 5, 15, 30, 40, 45, 50, 55, 60, and 65 minutes. Run 2 is followed by Run 3 and the condition of channel bed in the end of Run 2 is used as the initial condition of Run 3. In Run 3, uniform sediment with 2 mm diameter is fed constantly from the upstream end of the flume by a conveyor belt. Run 3 is continued until the time when the mean diameter of sediment discharge becomes the same as the mean diameter of fed sediment. Cumulative time steps for Run 3 are 10, 20, 30, 40, and 50. Total duration for Run 1, Run 2 and Run 3 is 535 minutes.

The experimental conditions are summarized in **Table 4.4**. The water depth, h , and the velocity, v , are the initial average water depth and velocity in each run, respectively. The elevations of the bed and water surface are measured at 0.025 m intervals for 7.0 m working length. These profiles are taken at the end of every step of each run. The surface bed material is sampled at the upper, middle, and lower locations before the first run and at the end of each run by surface excavation. The sampling points are located at 1 m, 3.5 m and 6 m downstream of the upper end of the flume. The bed material is excavated up to a depth corresponding to the coarsest grain size. All samples are air dried, weighed, and then sieved to get the grain size distribution of the surface layer.

Table 4.4 Conditions for experimental runs

Exp	Q_w (m^3/s)	q_s ($10^{-6}\text{m}^2/\text{s}$)	h (m)	v (m/s)	Fr	Time (min)
Run 1	0.0131	0	0.037	0.869	1.242	15, 30, 60, 120, 180, 240, 300, 360, 420
Run 2	0.0131	32.57	0.051	0.632	0.56	5, 15, 30, 40, 45, 50, 55, 55,60, 65
Run 3	0.0131	25.54	0.038	0.841	1.147	10, 20, 30, 40, 50



Photo 4.2 Sediment feeder

4.3.2 Estimation of porosity

To calculate the porosity values of bed material is carried out by these following steps. First, the bed material at each point representing the upper, middle and lower part are sieved to get the grain size distribution. Furthermore, the type of grain size distribution is determined based on value of parameter γ and β , which are calculated by the following equations:

$$\gamma = \frac{\log d_{max} - \log d_{50}}{\log d_{max} - \log d_{min}} \quad (4.11)$$

$$\beta = \frac{\log d_{max} - \log d_{peak}}{\log d_{max} - \log d_{min}} \quad (4.12)$$

where γ and β are geometric parameters.

After the values of γ and β are known, type of grain size distribution can be found by using the diagram proposed by Sulaiman (2008). Furthermore, the value of the porosity is calculated by the following equations:

a. Log normal distribution

$$\sigma_L^2 = \sum_{j=1}^N (\ln d_j - \overline{\ln d})^2 p_{sj} \quad (4.13)$$

$$\lambda = (-0.1414\sigma) + 0.3445 \quad \text{if } 1 < \sigma < 1.25 \quad (4.14)$$

$$\lambda = (-0.1058\sigma) + 0.3088 \quad \text{if } 0.75 < \sigma < 1.0 \quad (4.15)$$

where σ_L is standard deviation, d is grain diameter, j is class of grain size, p_{sj} is proportion of class- j and λ is porosity.

b. Talbot distribution

$$n_{T(x\%)} = \frac{\ln(f(d_{(x\%)}))}{\ln\left(\frac{\log d_{(x\%)} - \log d_{\min}}{\log d_{\max} - \log d_{\min}}\right)} \quad (4.16)$$

$$n_T = \frac{n_{T(16\%)} + n_{T(25\%)} + n_{T(50\%)} + n_{T(75\%)} + n_{T(84\%)}}{5} \quad (4.17)$$

$$\lambda = 0.0125n_T + 0.3 \quad (4.18)$$

where $f(d)$ is cumulative of percent finer, n_T is Talbot number.

4.3.3 A bed-porosity variation model

A bed-porosity variation model is one of numerical simulation methods for bed deformation. The difference between the proposed model with others previous numerical model is the model to analyze the change of porosity as well as the bed variation (Sulaiman, 2008). The porosity is assumed as a function of characteristic parameters of grain size distribution. The model is analyzed by the continuity equation of water, the energy equation of flow and the continuity equation of sediment. The basic equations are as follows:

(a) Continuity of water

$$\frac{\partial Bh}{\partial t} + \frac{\partial Q}{\partial x} = 0 \quad (4.19)$$

where B = channel width, h = water depth, Q = water discharge, t = time and x = distance in stream wise direction.

(b) Energy equation of water

$$\frac{\partial Q}{\partial t} + \frac{\partial}{\partial x} \left(\frac{1}{2} g B h^2 + \frac{Q^2}{B h} \right) = g B h (i_b - i_f) \quad (4.20)$$

where g = gravity acceleration, i_b = bed slope and i_f = energy gradient. The energy gradient can be expressed as follows:

$$i_f = \frac{n^2 v^2}{R^{4/3}} \quad (4.21)$$

where n = Manning coefficient, v = average water velocity, and R = hydraulics radius.

(c) Continuity equation of total sediment

Using the equation of continuity of sediment discharge shown below, the change of bed elevation is calculated.

$$\frac{\partial}{\partial t} \int_{z_0}^{z_b} \{1 - \lambda(t, x, z)\} dz + \frac{1}{B} \frac{\partial Q_s}{\partial x} = 0 \quad (4.22)$$

where λ = porosity of bed material, z_b = bed level, z_0 = a reference level, z = a vertical axis, and Q_s = sediment discharge.

(d) Continuity equation of each sediment fraction

Continuity equation of sediment mixtures is written as:

$$\frac{\partial}{\partial t} \int_{z_0}^{z_b} \{1 - \lambda(t, x, z)\} p_j(t, x, z) dz + \frac{1}{B} \frac{\partial Q_{sj}}{\partial x} = 0 \quad (4.23)$$

where j = grade of sediment fraction, p_j = mixing ratio of j -th fraction in bed material, and Q_{sj} = sediment discharge of j -th fraction.

(e) Porosity and grain size distribution

In the bed-porosity variation model, the porosity is assumed as a function of characteristic parameters of grain size distribution.

$$\lambda = f_n(\Pi_1, \Pi_2, \Pi_3, \dots) \quad (4.24)$$

where $\Pi_1, \Pi_2, \Pi_3, \dots$ = characteristic parameters of grain size distribution.

4.3.4 Results and discussion

(1) Experiment

The experimental results of bed variation in Run 1, Run 2 and Run 3 are shown in Figures 4.62(a), 4.62(b) and 4.62(c), respectively. In Run 1, sediment discharge during the first 15 minutes is big and most of fractions are transported. However, the finer fraction tends to be transported more than the coarser fraction. It is indicated by the mean diameter of sediment discharge in the first 15 minutes to be 1.14, which is smaller than the mean diameter of the initial grain size (2.7 mm). On the following time steps, the sediment discharge becomes smaller until an equilibrium condition (sediment discharge ≈ 0) and the mean diameter of sediment discharge also decreases. The bed degradation in the first time step as shown in Figure 4.62(a) also tends to be bigger than the bed degradation in the following steps. This phenomenon continues until the equilibrium condition of sediment discharge at 420 min. The bed degradation at the upstream boundary end is bigger than bed degradation at the middle and lower parts. At the lower boundary end, the bed degradation is smallest and there is no degradation. In the final step, the bed degradation takes place along channel and the final slope is estimated at 0.0056.

In the Run 2, the bed level goes up significantly in the upstream region during the first 15 minutes if sediment with the lognormal grain size distribution is supplied to the static equilibrium bed condition. The sediment discharge in the first step is relatively smaller than the sediment discharge in the following time steps. It describes that the most sediment feeding is deposited on the bed channel in the first time step, and then most sediment feeding is transported in the last time step. This condition continues until a new equilibrium condition is reached, as the sediment discharge is equal to the sediment feeding. However, in this experiment, the bed level in the part region goes up faster than the middle and lower region. The reason why the phenomenon takes place is due to the method of sediment supply process or the non-equilibrium bed condition. The discharge of sediment feeding is bigger than the sediment discharge in the channel, so that the bed level at the final step in Run 2 is higher than the bed level at the initial condition in Run 1, especially in the upper region.

In Run 3, the bed level in the middle and lower regions is increased slightly, but the bed level in the upper region is increase significantly. The method of sediment feeding is not so smooth in Run 3, so that the sediment is concentrated in the center of channel. This is the reasons why the bed level in the upper region is increased fast. However, it also indicates that if the porosity of sediment feeding is different, the sediment discharge in the channel is also different. If the porosity of sediment supply increases, sediment discharge in channel tends to decrease.

The grain size distributions of surface bed material at the upstream point ($x = 1$ m), the midstream point ($x = 3.5$ m) and the downstream point ($x = 6$ m) are shown in Figure 4.63. These samples are taken before Run 1 and the end of Run 1. The initial grain size distribution at all points is the lognormal type. The mean diameter of surface bed material at the upstream point, middle point, and lower point are 2.74 mm, 2.85 mm and 2.52 mm, respectively. In Run 1, no sediment supply from upstream end, so that the bed level goes down along the channel until equilibrium static condition is achieved. The fine sediment in the bed surface moves from the upstream region to downstream region. If the equilibrium static condition is reached, the surface material along the channel becomes coarser and the porosity of bed surface material increases. As a result, the grain size distribution at all points becomes the Talbot type. The mean diameter of surface bed material after Run 1 is 6.19 mm, 6.63 mm and 6.08 mm at the upstream, midstream and downstream, respectively. The porosity of surface bed material also changes, from 0.2 to 0.34 at the upstream point, from 0.2 to 0.37 at the midstream and from 0.19 to 0.35 at the downstream point, respectively. Photo 4.3 shows the final condition of the channel bed surface after Run 1, Run 2 and Run 3.

Figure 4.64 presents the grain size distributions of surface bed material at the upstream point ($x = 1$ m), the midstream point ($x = 3.5$ m) and the downstream point ($x = 6$ m) after Run 2. Sediment feeding in Run 2 (lognormal type) makes the bed material changing from Talbot type to lognormal type. The mean diameter of surface bed material changes from 6.19 mm to 2.62 mm at the upstream point, from 6.63 mm to 2.65 mm at the midstream point and from 6.08 mm to 3.11 mm in the downstream point. The porosity of surface bed material after Run 2 is 0.17, 0.18, and 0.19, at the upstream point, the midstream point and the downstream point,

respectively. The result describes that if sediment supply due to an eruption comes into downstream region, the sediment supply can recover the bed level, as well as the material of bed channel, to the initial condition.

The grain size distributions of surface bed material at the upstream point ($x = 1$ m), the midstream point ($x = 3.5$ m) and the downstream point ($x = 6$ m) after Run 3 are shown in Figure 4.65. Sediment supply from the upstream boundary end in Run 3 causes the surface bed material changing, although the type of grain size distribution is still lognormal. As a result, the mean diameters of surface bed material at the upstream point, the midstream point, and the downstream point change from 2.62 mm to 2.77 mm, from 2.65 mm to 2.88 mm and from 3.11 mm to 3.23 mm, respectively. Even though, these mean diameters change slightly, but the changes in porosity value are quite different. The porosity of surface bed material after Run 3 at the upstream point, the midstream point, and the downstream point are 0.29, 0.28, and 0.24, respectively.

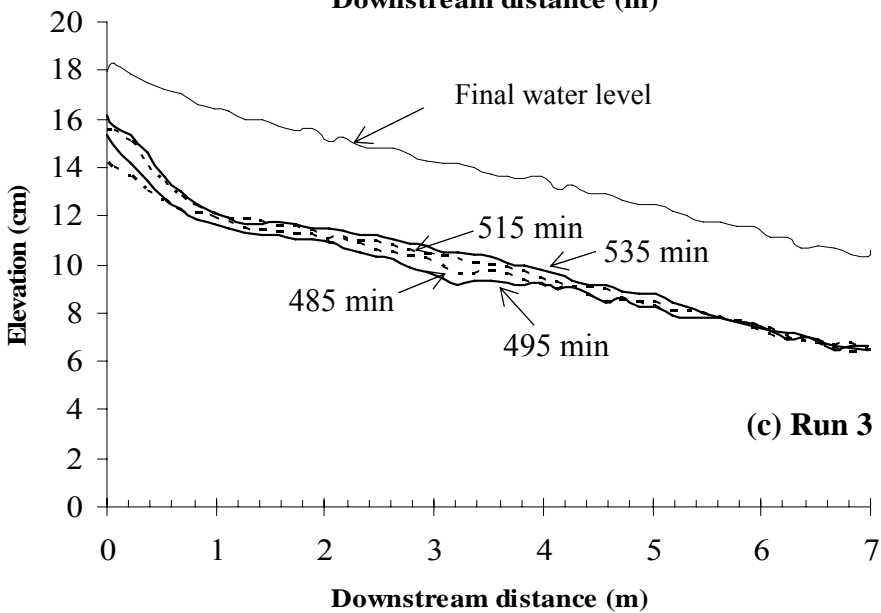
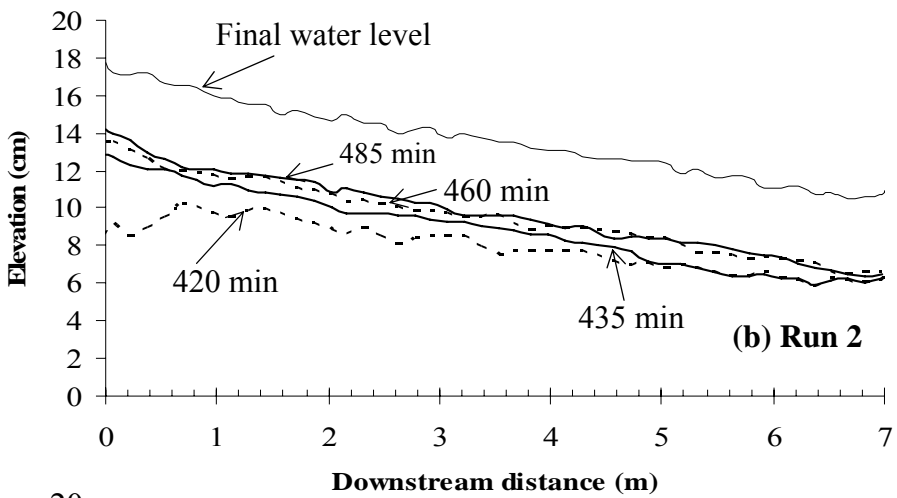
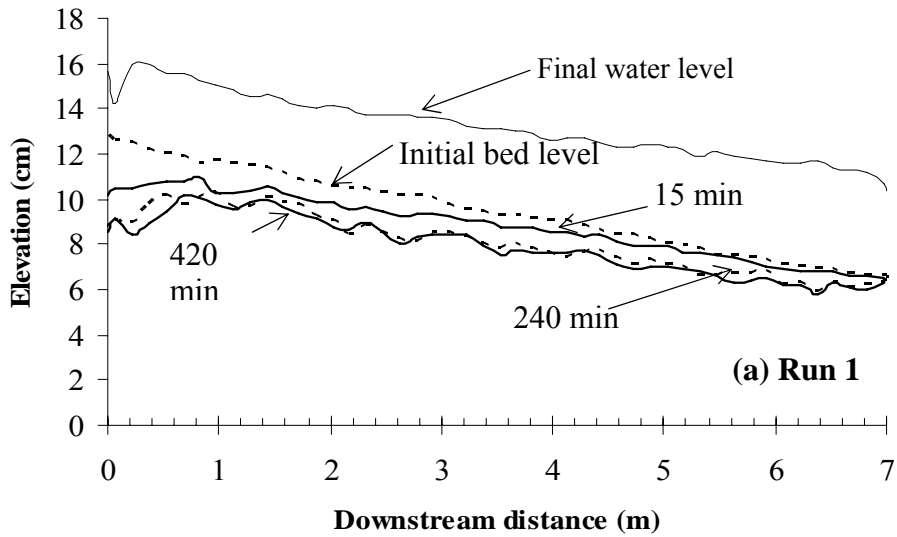

Fig. 4.62 Experiment results on bed surface and water surface in Run 1, Run 2, and Run 3.

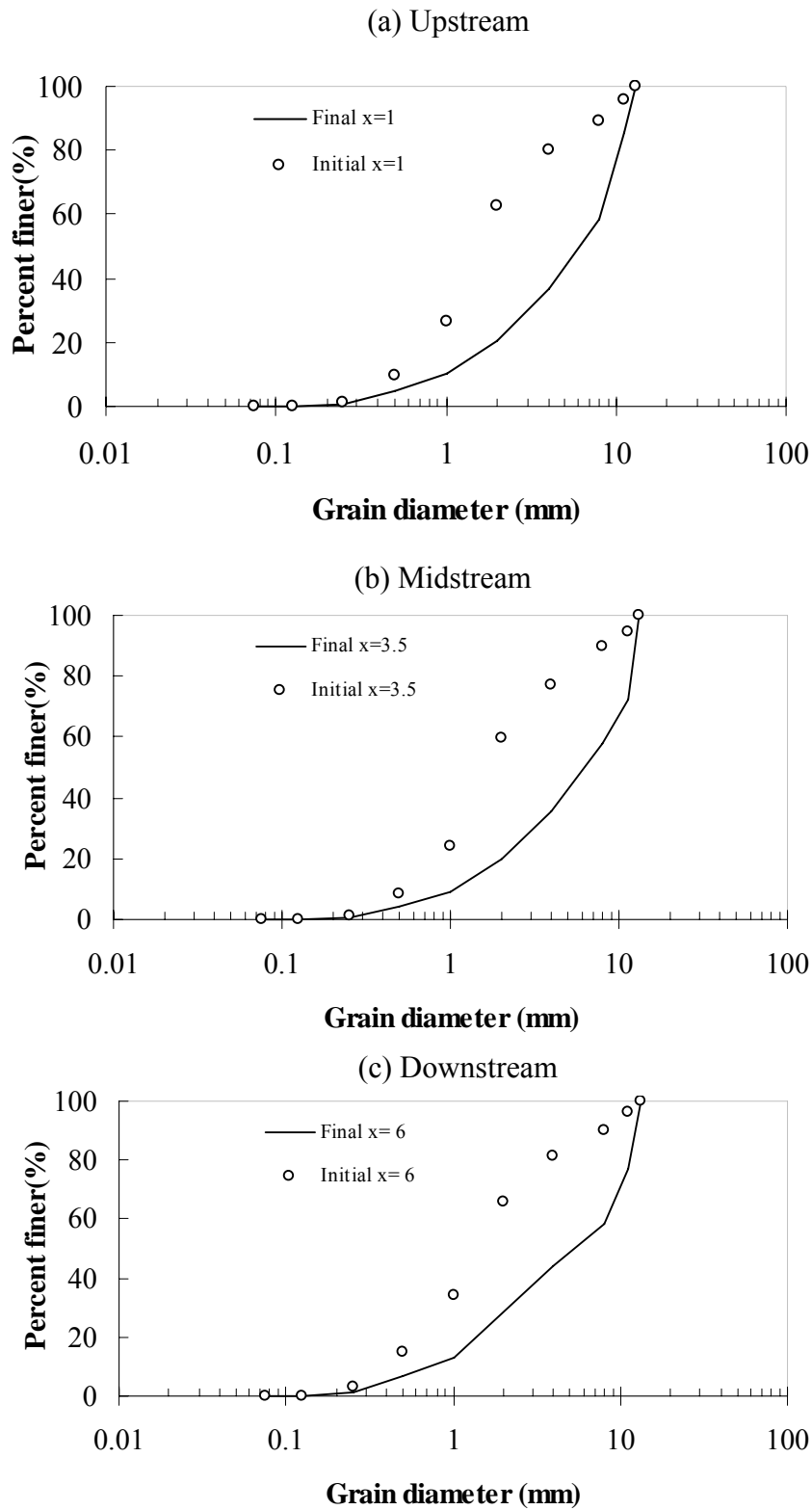

Fig.4.63 Grain size distributions of surface bed material at the upstream ($x = 1\text{ m}$), the middle stream($x = 3.5\text{ m}$) and the downstream ($x = 6\text{ m}$) after Run 1

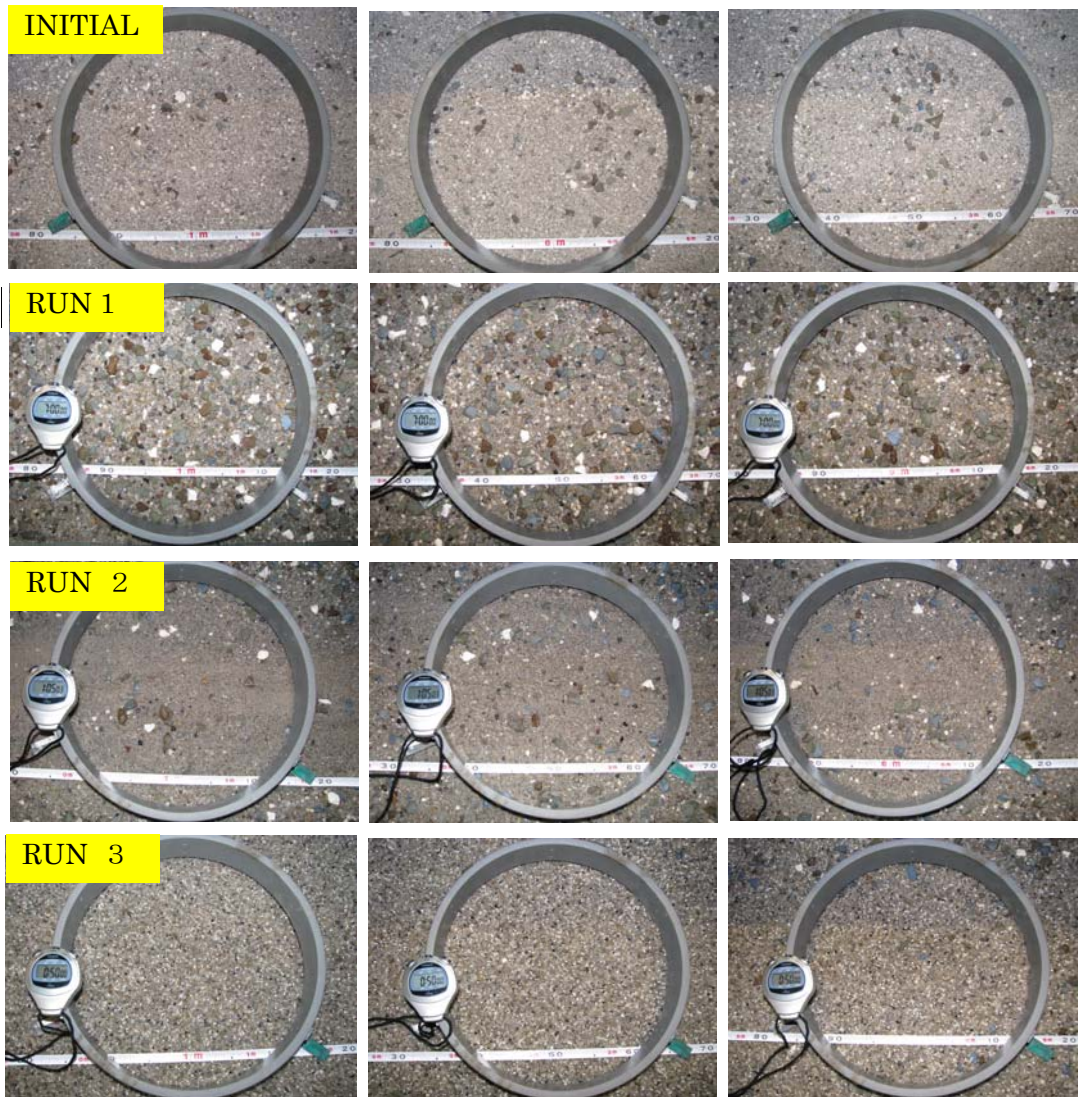

Photo 4.3 Final condition of the channel bed surface after Run 1, Run 2 and Run 3 at upper, middle and lower streams

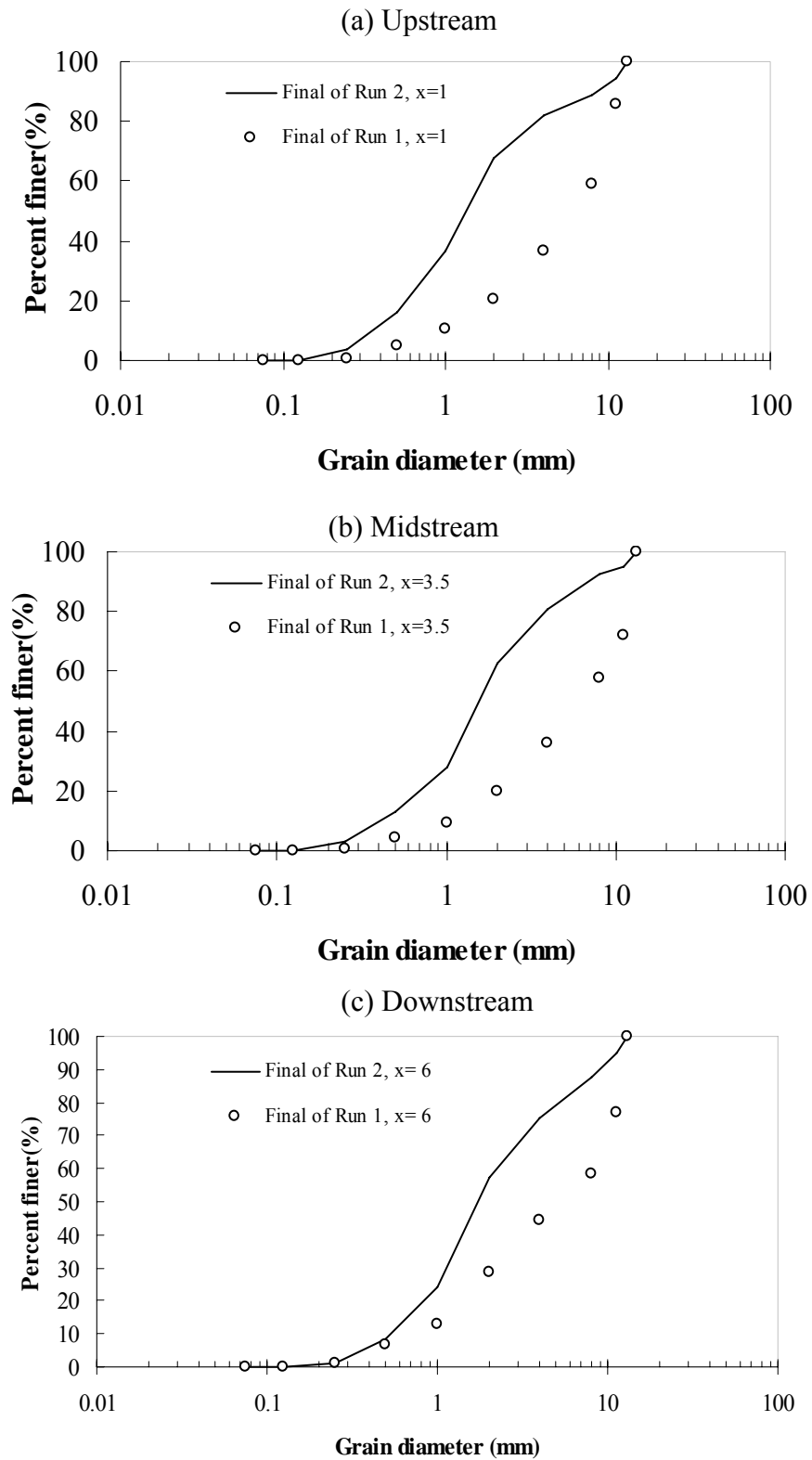

Fig. 4.64 Grain size distributions of surface bed material at the upstream ($x = 1\text{ m}$), the midstream ($x = 3.5\text{ m}$) and the downstream ($x = 6\text{ m}$) after Run 2

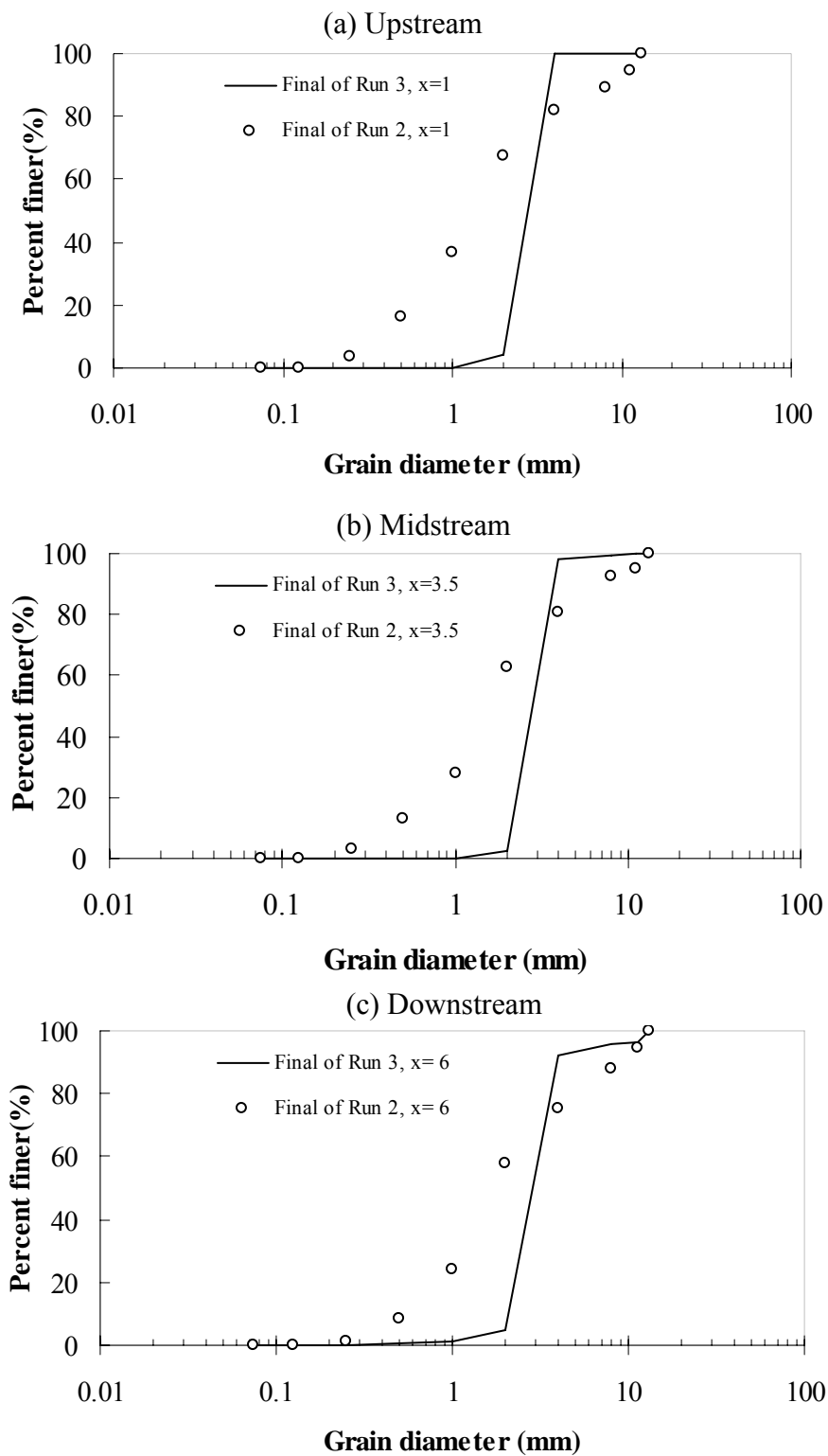

Fig. 4.65 Grain size distributions of surface bed material at the upstream ($x = 1\text{m}$), the midstream ($x = 3.5\text{ m}$) and the downstream ($x = 6\text{ m}$) after Run 3

(2) Simulation results

Figure 4.66 shows the comparisons of the simulation results with the experimental results. In Run 1, the experimental result shows that the bed degradation in the upstream region is very large. The simulation result shows that the degradation depth in the upstream region is rather small. However, the bed degradation of simulation has a good agreement with the experimental result in the midstream and downstream regions. Water surface elevation of the experimental results in the upstream region is higher than water surface elevation of the simulation result in the same location. In the downstream region, water surface elevation of experimental result is lower than water surface of the simulation result. Sulaiman (2008) also finds this phenomenon in his research.

In Run 2, water surface elevation of the simulation result has a good agreement with water surface elevation of the experimental result in whole of channel. The bed aggradation in the both results is relatively similar in the midstream and the down stream region. However, the bed surface of the experimental result is rather higher than the simulation result in the upstream region. In Run 3, the condition of the both results is similar with the result in Run 2. The disagreement between the simulation and the experimental results may be due to the boundary condition in the experiment that has not perfect, especially in the upstream boundary end. Hence, the model can produce reasonable results on bed surface elevation and water surface elevation.

Figure 4.67 shows the comparisons between the simulation results and the experimental results on the grain size changes of surface bed material at the upstream point, midstream point and downstream point. After Run 1, the surface bed material changes from the lognormal type to the Talbot type. Figure 4.67 (a) shows that the grain size of the simulation result and the grain size of experimental result are similar at the upstream point. However, the simulation result is not similar with the experimental result at the midstream and downstream points, as shown Figure 4.67 (b) and Figure 4.67 (c). In the experiment, most grain sizes are transported by flow, even though the finer grain tends to be transported more than the coarser grain. In the sediment mixture, the critical friction velocity of coarse material tends to decrease, but the critical friction velocity of the fine material

tends to increase. As a result, the both material can move to downstream together. In the simulation, the flow can select perfectly the grain size to be transported based on the critical friction velocity of each grain size. As a result, the mean diameter of surface bed material in the experiment changes faster than in the simulation, especially in the midstream and the downstream. It also means that the porosity in the experiment changes faster than that in the simulation.

Figure 4.68 shows the comparisons of the simulation results with the experimental results after Run 2. By sediment feeding, the grain size distribution of surface bed material can change to new type. The fine sediment fills the void between the coarse sediment. It causes the increase in the proportion of finer sediment in the surface layer and the decrease in porosity. As a result, the grain size type of surface layer will change from the Talbot type to the lognormal type. The decrease in porosity in the upstream region is larger than the midstream and downstream. In the experiment, the increase in the proportion of finer sediment in the surface layer is faster than that in simulation. The condition may be caused by the effect of sediment burial process. As the result, porosity of the surface layer in simulation is higher than that in the experiment.

Figure 4.69 shows the comparison between grain size change in the experiment and that in the simulation after Run 3. Uniform sediment supply can increase in the proportion of the grain size in the surface layer that is the same with sediment feeding, so that the material of surface layer tends to be uniform material and porosity increases. In the simulation, even if the sediment feeding can increase the proportion of the fraction that same as sediment feeding, but the coarse sediment remains in the surface layer, so that the uniform sediment cannot be formed. Consequently, porosity of surface layer in the experiment is higher than that in the simulation.

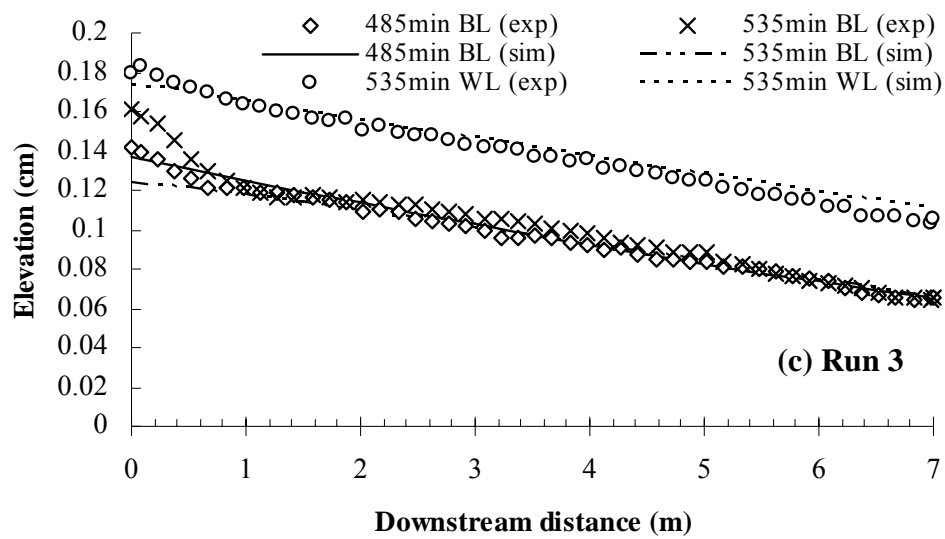
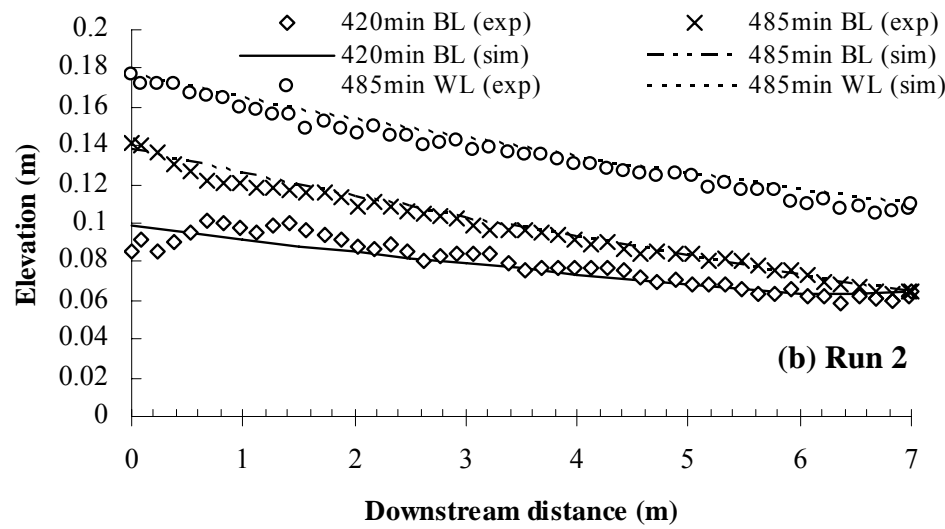
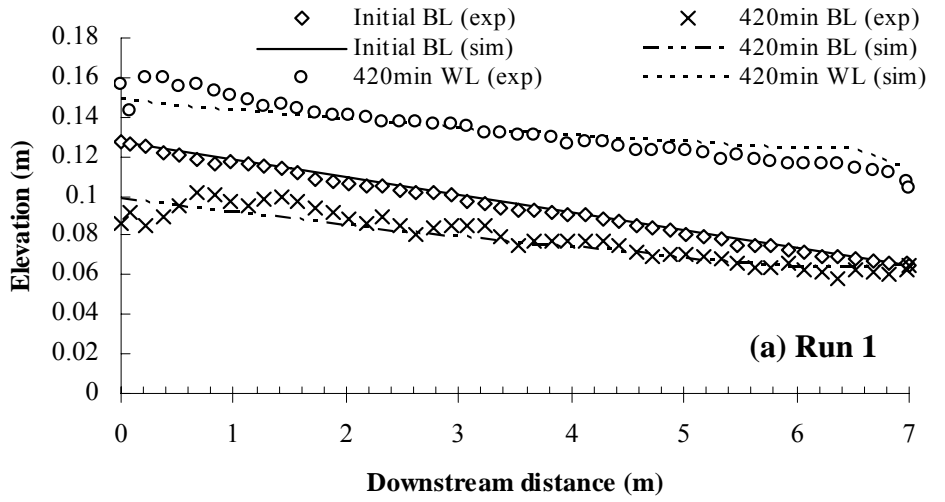

Fig. 4.66 Experimental and simulation results on bed surface and water surface

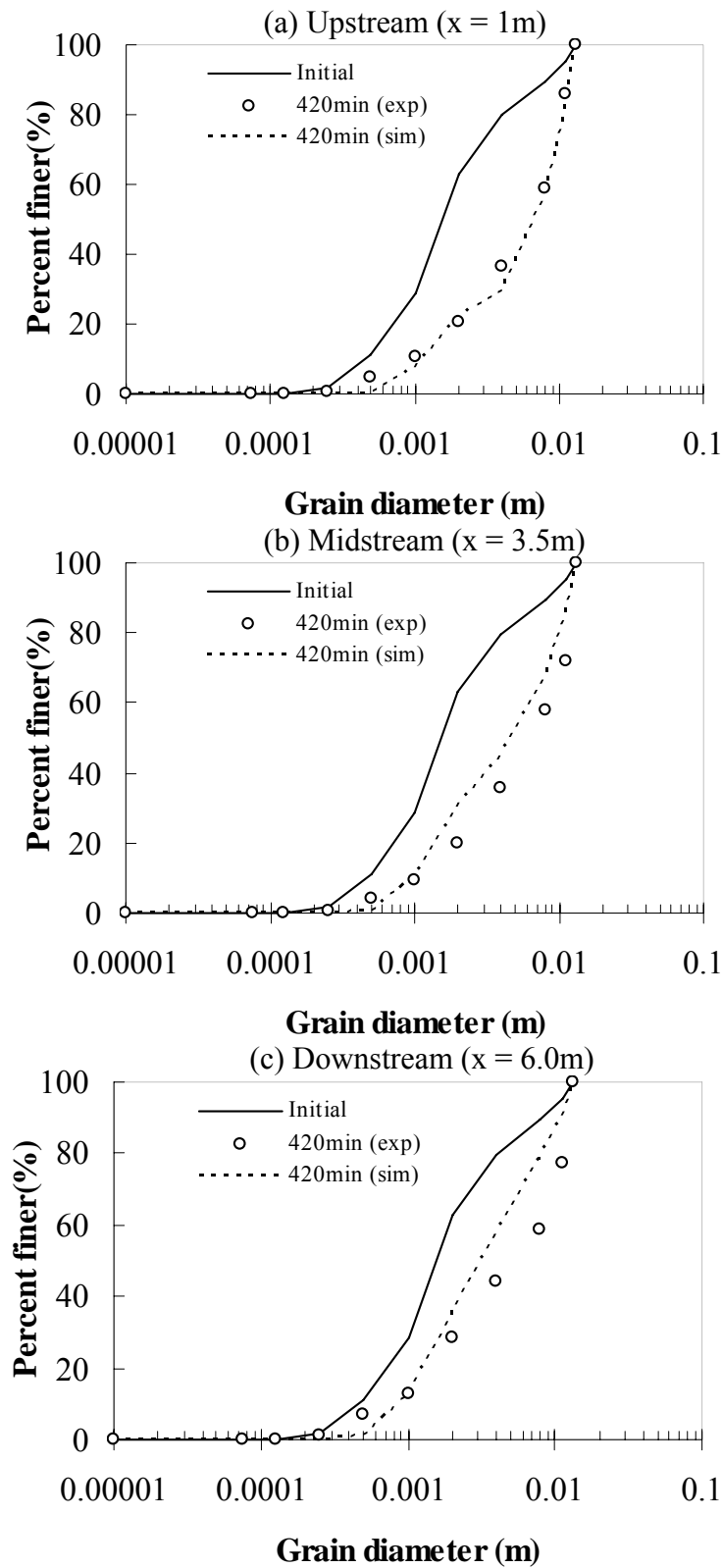

Fig. 4.67 Experiment and simulation results on grain size distributions of surface bed material after Run 1

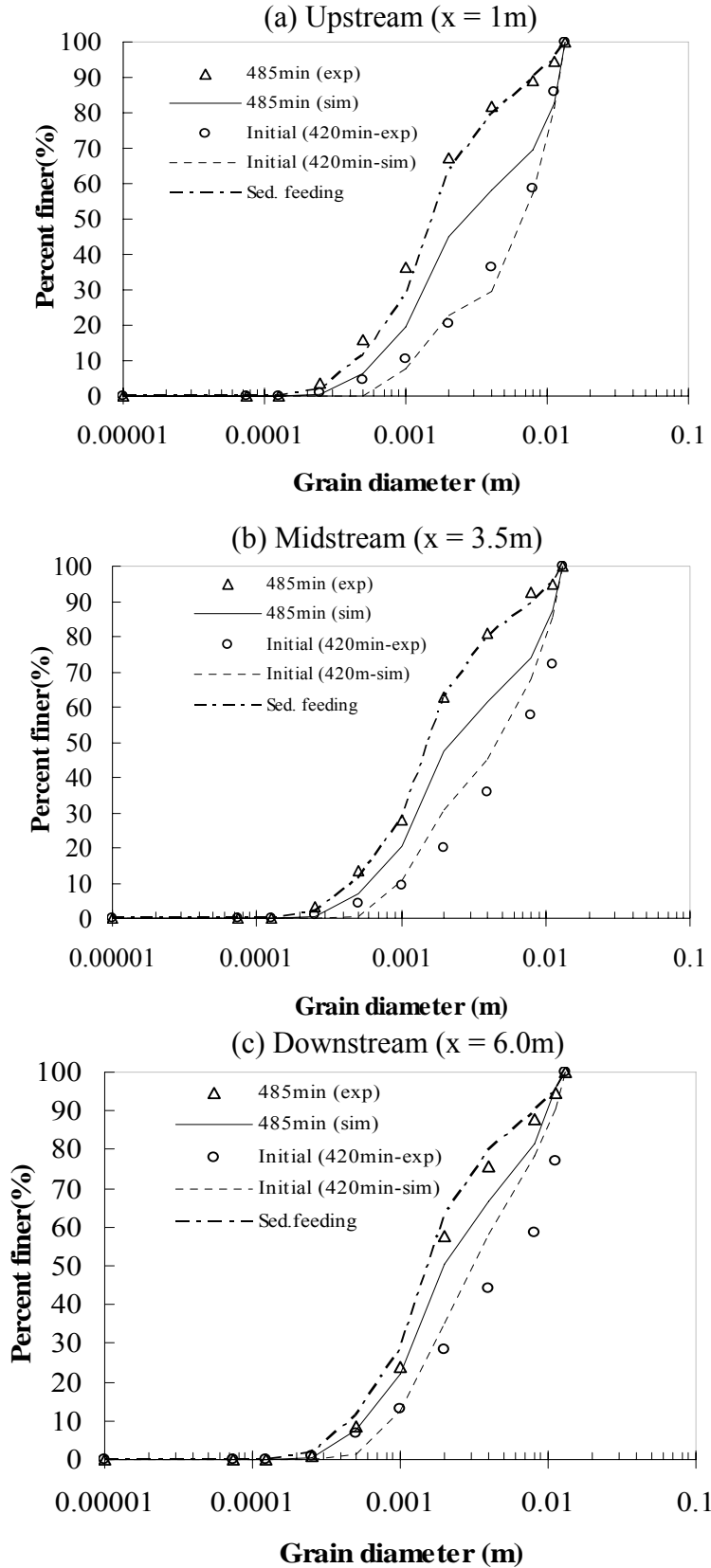

Fig. 4.68 Experiment and simulation results on grain size distributions of surface bed material after Run 2

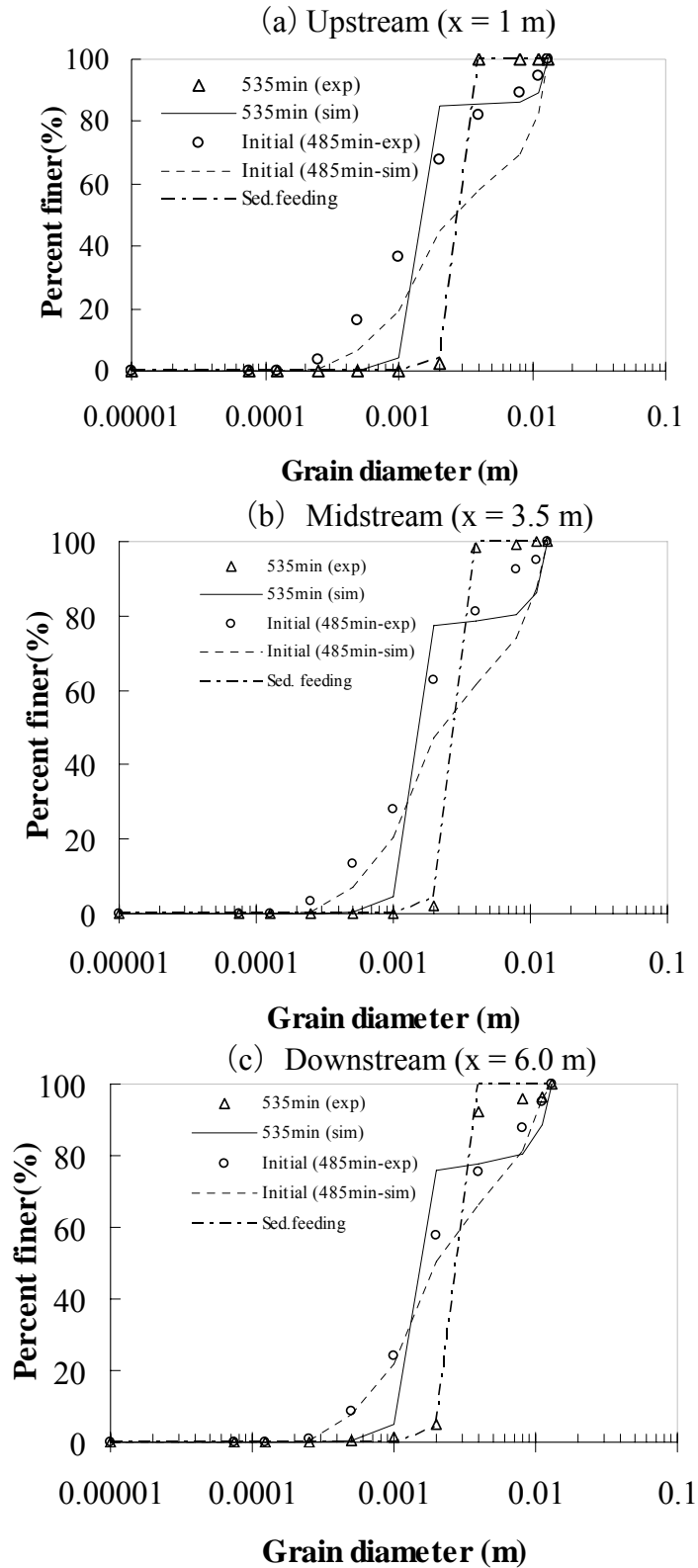

Fig. 4.69 Experiment and simulation results on grain size distributions of surface bed material after Run 3

4.4 Preferable Sediment Management

As described in Chapter 3, it is clear that people in upstream area are still threatened by sediment related disaster, besides they also use it as a resource. So far, the sediment management still tends to separate between the safety and the utilization aspects, and also still separates between the sediment management in the upstream and downstream areas. Whereas, sediment management for the purpose of certain aspect will affect the other aspects and sediment management in the upstream area will affect conditions in the downstream area. Based on the issues in upstream and downstream areas, the policy of sediment management to achieve the aim is as follows:

- a) To mitigate disaster due to the volcanic activity in the upper area,
- b) To stabilize riverbed in the lower Progo River and Opak River,
- c) Sustainable sand mining management,
- d) Regional development.

4.4.1 Disaster mitigation in upper area due to the volcanic activity

Referring to Chapter 3, Mount Merapi has been producing huge sediment volume. In the last eruption of 2006, the sediment production flow down into Gendol and Woro Rivers that lies on the southeastern slope. However, a pyroclastic flow is possible to attack every direction in the upstream tributaries; consequently, a debris flow is also possible to cause damage in every tributary. To countermeasure the sediment disaster, both the structural and non-structural measures are proposed. Thus, the both measures have to be planned to against sediment disaster due to volcanic activity in all tributaries, even though prioritization is also needed according to the direction of present volcanic activities. To control excess sediment discharge, the sustainable structural measures will be promoted by existing sabo works combined with excavation of sand and gravel deposited in sabo dams and sand pocket. Non-structural measures, such as monitoring, forecasting, warning and evacuation, is used as the main measures for mitigating pyroclastic flow disasters. Since non-structural measures, especially evacuation is the effective activity against disasters and a very important component of disaster prevention system, a practical and substantial for evacuation is necessary to be made. So far,

Standard Operating Procedures (SOP) for evacuation in four regencies located in surrounding of the Mount Merapi has been conducted based on the Head of District Decrees and Governor Decrees (Fathani and Legono, 2010). Two districts, consisting of Klaten and Sleman districts already provide the SOP of evacuation from regency level to village level. However, there is no SOP for evacuation activities from each house to temporary evacuation shelter in village level. Therefore, it is needed to establish a Standard Operating Procedure for evacuation.

4.4.2 Riverbed stabilization in the lower Progo River and Opak River

As described in Chapter 2, riverbed stability condition in both rivers, Progo and Opak Rivers, is very severe. In the downstream of the both rivers, especially the Progo River, many river structures are important to support social and economic activities. Three bridges are very important as social infrastructures to connect this area with western Java and eastern Java. Since Bantar bridge is a part of the national transportation system. The traffic volume through the bridge is very heavy. Further, an oil pipeline that located at Bantar Bridge is an important oil conveyor with 8 million liter/day. At Bantar Bridge, there is also located a railway bridge that connect Surabaya and Jakarta. Other two bridges, Srandakan and Kebon Agung Bridges, connect Yogyakarta and Wates, sustaining the regional transportation system for the region. Those three bridges are important infrastructures to support the regional economy and society. Instability of the bridges due to riverbed degradation induces serious negative impact on the region.

The main industry in the study area is agriculture. The irrigation for agriculture for paddy rice is practiced extensively and intensively to support the self-sufficiency of staple food policy in the study area. Stable supply of water is indispensable to increase in agriculture productivity. Unfortunately, Sapon and Kamijoro irrigation intakes have problem in conducting water to irrigate 4,500 ha of land due to the riverbed degradation. In downstream of Opak River, the negative impacts due to riverbed degradation start to be serious, even if the problems are not so severe comparing with situation in the downstream of Progo River. To countermeasure the riverbed degradation in the both rivers, sediment management is proposed as follows.

(1) Progo River

In the present condition, the riverbed degradation in the downstream of the Progo River continues, even if a groundsill has been constructed at Srandakan Bridge. The riverbed in the upstream of the groundsill can be protected by the groundsill (Ikhsan *et. al.*, 2010). Riverbed at Kamijoro intake and Bantar Bridge that located 16.8 km and 26.5 km from estuary, the riverbed degradation is estimated at 6.94 cm/year and 10.6 cm/year, respectively. On other hand, sand mining activities in the lower Progo River are still active, so that the riverbed degradation rate at both locations is faster than the prediction. According to DGWR report (2001a), the riverbed degradation at Kamijoro Intake and Bantar Bridge were estimated at 9.77 cm/year and 28.9 cm/year, respectively. To overcome the issues associated with the riverbed degradation, an implementation of riverbed stabilization is required. This effort aims to secure the existing bridges from the future collapse and to restore function the existing irrigation intakes for 4,500 ha of agricultural land. As the result, the regional society and economy can be sustained. To achieve the goal, structural and non-structural measures are proposed. The structural measure can be done by a groundsill installation at the two other bridges and the two irrigation intakes. Non-structural measure is the sustainable sand mining management in the slopes of Mount Merapi basin and banning sand mining along the downstream of the Progo River. However, the sand mining management requires a quite long time to establish regulation, the structural measure is important to be implemented immediately.

(2) Opak River

To overcome the riverbed degradation in the downstream of Opak River is proposed through structural and non-structural measures. Structural measure is to reconstruct the groundsill at Kretek Bridge and non-structural is prohibition of sand mining activity in the lower of Opak River. The government of Bantul district has attempted to stabilize riverbed using non-structural measure through provision of venture capital for sand miners in this area. Fast and urgent measure is the structural measure, because controlling sand mining activity needs a long time.

4.4.3 Sustainable sand mining management

In Chapter 3, the method how to determine the allowable sand mining volume has been discussed and according to the results, the allowable sand mining volume is estimated at about a half of the annual average of sediment production. However, to control sand mining volume in the implementation level is not simple, because it induced the new social problems such as decreasing income of local people and reducing employment opportunities. Moreover, the present sand mining management is done by three districts with policy differences. Sand mining activity in Mount Merapi involves governmental and non-governmental institutions, from national level to village level.

In fact, some previous decrees were used for controlling sand mining volume at the national level; nevertheless, there are no regulations to control at provincial and district levels. Since problems due to uncontrolled sand mining around Mount Merapi have become serious issues, several meetings regarding with the sand mining management have been conducted. As a result, stakeholders, local community, and governments will propose the establishment of the Sand Mining Management Institution. However, the institution has not been established until now.

The uncontrolled sand mining has caused the crucial issues that induce environmental and social problems, specifically:

- a. Expansion of non-registered sand miners causes negative impacts such as conflict on quarry, mining in non-recommended areas, and conflict between registered and non-registered miners and so on.
- b. Improper excavation such as riverbank excavation and wrong quarry site induces bank collapse, landslide disasters, instability of river facilities and so on.
- c. Excess transportation causes damage to public roads, dust, and noise.

Based on the problems as explained sub-section 3.2.4, the proposed sand mining management will consider aspects such as sand mining license, retribution, improper mining, excess transportation, and overall control by watershed.

(1) Sand mining license

The main goal of mining license is to control mining and collect tax through the issuance and supervision of license. Therefore, province and districts regulations stipulate that a miner have to have a license. However, at present, 40% sand miners are not registered. Difficulties in promotion of mining licenses are associated with the long procedure of the license accession, a lack of monitoring and guidance of licenses and the penal regulation is not strict. To overcome these problems, it is necessary to make license procedure simple and village government should coordinate how to get the license mining for local people. Maybe, the recommendation of DGWR study (2001a) to establish an institution that has task to conduct the issuance of license, technical guide, and regular monitoring, is necessary to be considered. However, the recommendation is rather difficult to be done. If all sand miners are registered, as a result, it is the best way to control volume and location of sand mining activities.

(2) Retribution

As mentioned before, the problems in taxation system are the difference system among other governments and distribution of control gates is not well organized. To improve the tax collection system, the participation of local community as village cooperative institution is important, so that it is expected that the tax collection is more smooth conducted by local community. The other measure is determination of the uniform taxation among districts. Coordination to determine the taxation should not be conducted by only districts located in the mining area, but also other district located outside the mining area, since sediment control over the watershed is necessary to be considered. Hence, coordination and meeting among the districts surrounding in Mount Merapi area are needed to examine taxation and to revise sediment control plan.

(3) Improper mining

Due to the autonomy, the district governments conducted the sand mining control and it is quite difficult to control and determine the sediment balance over the watershed. In addition, there is a lack of public awareness regarding necessity

of sand mining control, because the sand mining is a good cash income for local people. Overcoming the above mentioned problems, the sediment control task should be conducted by participation of all districts and one institution equipped with technical ability to control and determine sediment balance over watershed. The participation of community and NGO also requires to solve the social problems due to mining control. Public participation is more important and effective to enhance public awareness. To provide an alternative income as instead of sand mining activity, the rehabilitation of irrigation weirs is important to reinforce and sustain the agriculture. As a result, alternative income source through the agriculture can give contribution to the mining control.

(4) Excess transportation

The excess transportation such as the heavy traffic volume and overloading, have induced deteriorating the important roads for community. This problem can be mitigated by providing stockyards nearby main roads. A small truck transports sand from quarry to the stockyards. Besides, rural roads should be improved.

(5) Overall control by watershed

The problems due to uncontrolled sand mining have taken place in not only mining sites, but also in downstream area. Thus, the sand mining management requires the participation of all districts located in the upstream and downstream area. Finally, the sand mining management with considering the sediment balance over the watershed can be reached. A neutral institution is necessary to be established to conduct the mining management for mutual agreement among districts and stakeholders. Besides, the institution should coordinate with the disaster management institution to use the sand mining management as a part of sediment disaster mitigation to protect assets, social infrastructure, and people lives.

4.4.4 Regional development

Since agriculture is as a main industry in the study area, the regional development is required to sustain the agriculture by increasing productivity and

diversifying crops. Therefore, the stable supply of irrigation water is an important issue to support the agriculture development in the area. For stable supply of water irrigation, it can be achieved with rehabilitation of existing irrigation structures damaged due to debris flows. To support the regional development, multiple uses of sabo works can be promoted for social infrastructures such as using the crest of sabo dams as a bridge, using sabo dams for irrigation intake and using evacuation road as rural road. As a result, the regional development can generate the new source income for succeeding sand mining income.

4.5 Summary

People manage and control sediment due to some reasons, such as utility, safety, and environment interests. There are relationships among these aspects; change in one aspect by a sediment management policy will affect on the two other aspects. Changes in the environmental, safety and utility interests will cause the change in the socio-economic condition.

Local people have large opportunity to get job as sand miners and local governments get an additional tax, if the present sediment management is maintained. However, the sediment management will give serious negative impacts on environment and safety aspects. To overcome the environment and safety problems, some cases of sediment management are discussed. As a result, job opportunities for local people and additional revenue for local government decrease. The combination between sand mining management and channel works installation is the best way to solve the sediment problem case in Mount Merapi basin, even though the sediment management also induces the negative impact on socio-economic conditions.

To determine the impact of sediment management on riverbed material can be used one dimensional porosity variation model that have been developed by Sulaiman (2008). The model can simulate the riverbed variation, grain size change, and porosity of riverbed material. Based on the verification using the experiment, the model gives a good performance on riverbed variation, including the water level change. At present, the model can simulate a unimodal grain size distribution. Regarding simulation on grain size and porosity change of riverbed material, the

simulation result has given a good trend. However, the model is necessary to be developed, so that it can be used to simulate the bimodal grain size distribution.

The sediment management based on this study result aims to overcome the issues in upstream and downstream areas. The policy of sediment management attempts to achieve disaster mitigation due to the volcanic activity in the upper area, riverbed stabilization in the lower Progo River and Opak River, sustainable sand mining management and regional development. Regarding the sand mining management, it will consider aspects such as sand mining license, retribution, improper mining, excess transportation, and overall control by watershed. To support the sand mining management, the coordination of all districts in the watershed and community participation is important. Further, the regional development is required as one way to control the excess of sand mining volume.

References

- Aisyah, S., (2008), *Economical potency of sand mining on the Gendol river*, Thesis presented to Gadjah Mada University (in Indonesian).
- DGWR, Republic of Indonesia, (2001a), *Review master plan study on Mount Merapi, main report*.
- DGWR, Republic of Indonesia, (2001b), *Review master plan study on Mount Merapi. supporting report [B] volcanic disaster mitigation plan*.
- Fathani, T.F., and Legono, D, (2010), *A self-evacuation drill development program for community resilience against Mount Merapi Disaster*, Proceeding of International Workshop on Multimodal Sediment Disasters Triggered by Heavy Rainfall and Eartquake and the Countermeasures, pp. 125-136.
- Ikhsan, J., Fujita, M., and Takebayashi, H., (2010), *Study on sediment disaster management in volcanic area by considering disasters mitigation and resources management*, International Workshop on Multimodal Sediment Disasters Triggered by Heavy Rainfall and Eartquake and the Countermeasures, pp. 67-76.
- Kelman, I., and Mather, T.A., *Living with volcanoes: the sustainable livelihoods approach for volcano-related opportunities*, Journal of Volcanology and Geothermal Research, Vol. 172, pp.189-198.
- Mancini, L., Rosemann, S., Puccinelli, C., Ciadamidaro, S., Marcheggiani, S., and Aulicino, F.A., (2008), *Microbiological indicators and sediment management*, Ann Inst Super Sanita, Vol 44, No. 3, pp. 268-272.
- Owens, P.N, (2005), *Conceptual Models and Budgets for Sediment management in the river Basin Scale*, Journal Soils and Sediments, Vol 5, No. 4, pp. 201-212.
- Sulaiman, M., (2008), *Study on Porosity of Sediment Mixtures and a Bed Porosity Variation Model*, Thesis presented to Kyoto University.

Chapter 5

Conclusions and Recommendations

5.1 Conclusions

Sediment production in a basin is influenced by natural condition and human-induced impacts. Sediment poses problems when there is too little sediment or also much sediment in river basins. Landslides, floods, debris flows, and pyroclastic flows commonly cause sediment disasters. To prevent the sediment disasters caused by mass movement, people use the sediment control structures, such as training dike, sand pocket, and sabo dams. On the other hand, the mass movements also give sediment as resources for human beings, as the fertile soil, and as construction material. However, when people use sediment as resources, ignoring its sustainability is happen very often. Consequently, it will produce another type of sediment disasters, i.e. degradation, instability of river structures and so on. Hence, it is necessary to consider both control of sediment disaster and sediment resources management. So far, control of sediment disaster and sediment resources management tends to be separated, whereas, the both have influences one to each other. Combination between control of sediment disaster and resources management is required to achieve better results in sediment management.

Mount Merapi is one of the most active volcanoes in the world. It is located at the vicinity of Yogyakarta city in central Java Island, Indonesia. Mount Merapi has been giving various volcanic activities, such as eruptions, lava flows, pyroclastic flows, glowing clouds, volcanic ash falls, and volcanic debris flows. The produced sediment has been causing many disasters for local residents. On the other side, the sediment has a good quality and is popular as construction material, so that people use it as a resource through sand mining activities. The sand mining activities have given some advantages for rural/local people and local governments. However, uncontrolled sand mining has caused problems in the watershed such as instability of groundsills, bridges and so on due to bed degradation. Based on these

reasons, it is very important to manage sediment to reduce its risks while, on the other hand, to use it as a resources.

This study focuses on the development of a framework of sediment management in active volcanic basin considering sediment disasters and resources management, and Mount Merapi basin in Indonesia is selected as a case study. The objectives of this study were: (1) to figure out the socio-economic and environment conditions in Mount Merapi basin as a basis of sediment management in the area, (2) to develop a concept of sustainable management of sediment resources, (3) to develop a framework of sediment management, which considers sediment disasters and sediment resources for volcanic active basin and (4) to develop a method to evaluate the effect of sediment management from socio-economic point of view.

In **Chapter 2**, the socio-economic and environment conditions in surrounding area of Mount Merapi have been mentioned. A questionnaire survey for inhabitants and literature investigation were carried out. The result shows that sediment is an important resource to support inhabitants' daily life through sand mining activity. The activity has a positive socio-economic impact on Mount Merapi basin by providing job opportunities and giving additional income for inhabitants as well as local government. Agriculture still becomes a main industry for inhabitants in the area. Most of inhabitants have main occupation in the agriculture sector and part of them live under poverty conditions. Inhabitants and local government give a good awareness to sabo works. Sabo works have constructed for two purposes; first for sediment disaster mitigation and second for supporting regional development such as bridges and an irrigation water intakes. As a result, safety is secured and transportation access is more convenient. Since 2000, the population rate in the area changes fast. However, due to the excessive sediment resources use, the environmental condition in Mount Merapi basin tends to be worse due to riverbed degradation and instability of river infrastructures. Hence, it is necessary to develop a new concept of sediment management in Mount Merapi basin.

In **Chapter 3**, the volcanic activities of Mount Merapi, as the main source of sediment in the area, were point out, including the problems that appeared in the sediment disasters and resources management in Mount Merapi. Its eruptions

have produced large amounts of volcanic material as ash falls, lava, and pyroclastic flows. Produced sediment deposited on the slopes of Mount Merapi and threatened local residents. To mitigate the sediment disasters due to the deposited sediment, there are two kinds of countermeasures in disaster management, namely structural and non-structural countermeasures. On the other hand, the deposit sediment has a good quality for construction. Due to the increasing consumption of sand, the sand mining has extended rapidly involving of mining companies with heavy equipment. The sand mining activity has increased significantly since 1999; when the regional governments have been given and broaden autonomy. The sediment resources management has given benefits for people through sand mining activity, but they neglected sediment sustainability and environment conservation. In addition, the implementation of the both management tends to be separated. Sustainable sediment management by considering disasters and resources aspects was discussed.

The main problem in sustainable sand mining management is how to determine the allowable sand mining volume. The steps to determine the allowable sand mining volume were presented. A designed bed slope, the sediment discharge to the sea, and the allowable sand mining volume are determined step by step based on the designed sediment supply rate. To consider the two aspects of sediment, namely resources and disasters, a framework has been developed using a one dimensional bed deformation analysis. The sustainable management using consolidation works has been presented. By considering the current conditions in the downstream area, the proposed sediment management has recommended to install a series of groundsills in the study area. The effects of sediment mixture on the simulation results were also described. A framework to take into account of the sediment problems in upper area has been developed. It is indicated that the combination among disaster mitigation, controlling sand mining and riverbed stabilization is necessary to be implemented.

In **Chapter 4**, the effects of sediment management on safety, utilization and environment aspects were discussed. To evaluate the effects of the sediment management from utilization point of view, the parameters of socio-economic were used, namely job opportunity, additional income of local people and tax income.

The risk degree of river infrastructures was used to describe the effect of sediment management on safety aspect. As a case study, effect of sediment management on safety is discussed in this paper, taking bridge and water intake structures as an example. To determine the risk degree of a bridge, we proposed three parameters, that are RP_1 (the risk degree of foundation function), RP_2 (the risk degree of pier function) and RP_3 (the risk degree of bridge function). RP_4 (the risk degree of sedimentation) and RP_5 (the risk degree of water intake function) have been introduced to measure the effects of sediment management on a water irrigation intake. To evaluate the effects of the proposed sediment management on environment, the mean diameter of grain size distribution of surface bed material was used. Based on the three aspects, the direction of change in basin situation by sediment management can be forecasted, so that the most preferable sediment management can be decided.

An experimental flume test has conducted to evaluate the effect of sediment supply on the riverbed change. The riverbed variation, grain size change and porosity change are used to estimate effects of sediment management on environment. Using the experimental results, one-dimensional bed porosity variation model has been verified. Based on comparing the simulation result to the experimental result, it shows that one dimensional bed porosity variation model can be simulate the experimental result well. Therefore, the model can be used to predict impacts of sediment management on environment.

5.2 Recommendations

Future study is required to improve this method for deciding which the appropriate sediment management is. The following points are recommended to be considered:

- 1) To describe the effects of sediment resources use, the sediment resources use in the upper area has considered in this study. However, the sediment resource use occurred in the middle and the lower areas. Hence, it is needed some efforts to take into account the phenomenon. In addition, the sediment use is as a function of location and time.

Therefore, the features in the field are necessary to be considered in sediment management.

- 2) To evaluate the effect of sediment management on environment aspect in this study, the mean diameter of surface bed material was used. However, many parameters can represent the environment condition, such as turbidity, porosity, and grain size. To select and decide the good sediment management, these parameters are necessary to be considered.
- 3) From socio-economic point of view, there are many aspects for evaluating the effect of sediment management. The proposed method in this study can be used to evaluate the effect of sediment management. However, the aspects considered are not enough and the standard for evaluation is simple, so that it may be recognized as a primary method. This study should be developed collaborating with social, economic and environment researches, so that an integrated evaluation of the effect of sediment management can be achieved.
- 4) This study is addressed to manage sediment in an active volcanic basin. Whereas, the number of non-active volcanic and non-volcanic basins is more than the number of active volcanic basin. Therefore, developing the framework of sediment management for both basins is also necessary.

List of Figures

Fig. 1.1	Distribution of the landslide events and its effects on human beings from 1900 to 2010 (Source: CRED, 2010)	8
Fig. 1.2	Change in annual temperature and annual rainfall in Indonesia. Adapted from Hulme and Sheard (1999) (Source: Case et al., 2007)	13
Fig. 1.3	Summaries of sediment related disasters and its effects on human beings in Indonesia from 1900 to 2010 (Source: CRED, 2010)	16
Fig. 1.4	A diagram of two aspects function of sediment, as resources and disasters	17
Fig. 1.5	Location of Mount Merapi, Indonesia	18
Fig. 2.1	The locations of the questionnaire survey	30
Fig. 2.2	The locations of the questionnaire survey by slopes	31
Fig. 2.3	The locations of the questionnaire survey by administrative	32
Fig. 2.4	The education background of respondents	43
Fig. 2.5	(a) The main occupation and (b) the additional/second occupation of households	44
Fig. 2.6	The total percentage of the main and the additional occupations of households	44
Fig. 2.7	Monthly incomes of households	45
Fig. 2.8	Respondent's opinion on importance of the sand mining activity	46
Fig. 2.9	Respondent's opinion on Mount Merapi eruption	47
Fig. 2.10	Respondents opinion on the disasters of Mount Merapi that cause a biggest damage	48
Fig. 2.11	Disaster response of respondents	48
Fig. 2.12	Respondent's opinion on river function	49
Fig. 2.13	Respondent's opinion on the biggest damage of the river	50
Fig. 2.14	Respondent's opinion on the riverbed degradation and fish population condition	51
Fig. 2.15	Respondent's opinion on the sabo works	51
Fig. 2.16	Location of study area; Magelang (1), Boyolali (2), Klaten (3) Sleman (4), Kulon Progo (5), Bantul (6) and Yogyakarta (7)	53

Fig. 2.17	Location of selected sub districts and circumstance surrounding Mt. Merapi area (modified from Lavigne and Thouret, 2002)	55
Fig. 2.18	Population growth at selected sub-districts in Sleman district	55
Fig. 2.19	Population ratio of 2005 to 1990 and 2000	56
Fig. 2.20	Respondent's opinion on sediment related disaster, before and after project	56
Fig. 2.21	River system in Mount Merapi basin	63
Fig. 2.22	Progo River basin and Opak River basin	64
Fig. 2.23	Location of the important structures in the downstream of Progo River	67
Fig. 3.1	The historical activities of Mount Merapi	79
Fig. 3.2	Location of sediment deposits in Mount Merapi. (1: Summit lava dome and andesitic lava flow, 2: deposits from Merapi volcano, 3: main cities) (Modified from Lavigne and Thouret, 2002)	79
Fig. 3.3	Cumulative volume of lava production of Mount Merapi	80
Fig. 3.4	Sediment balance in Mount Merapi basin	82
Fig. 3.5	Diagram of dominant directions of pyroclastic flows (Modified from DGWR, 2001b)	84
Fig. 3.6	The number of debris flows in every river on the slopes of Mount Merapi (Source: DGWR, 2001b)	87
Fig. 3.7	The hazard map of Mount Merapi (Source: Yoda Karya, 2008)	90
Fig. 3.8	Flowchart of the early warning of sediment related disaster in Mount Merapi (modified from DGWR, 2001b)	94
Fig. 3.9	Location of sand mining activities on the foothills of Mount Merapi (source: DGWR, 2001a)	95
Fig. 3.10	Distribution of sand mining volume by rivers in 2000 (source: DGWR, 2001c)	96
Fig. 3.11	Sand mining locations and its activity on the lower Progo River	97
Fig. 3.12	Distribution of miners in Mount Merapi basin(source: DGWR, 2001c)	98
Fig. 3.13	Flowchart of sand mining letter permits	99
Fig. 3.14	The sand mining tax of each district in Mount Merapi basin	101
Fig. 3.15	The ratio of sand mining tax to total tax	101

Fig. 3.16	Estimated sand mining volumes of each district around Mount Merapi	103
Fig. 3.17	Effects of Mount Merapi eruptions on sand mining activities from 1960 to 1992	104
Fig. 3.18	Effects of Mount Merapi eruptions on sand mining activities from 1992 to 2006	106
Fig. 3.19	Effects of pyroclastic flows, the economic crisis, and the regional autonomy on sand mining activities	107
Fig. 3.20	A Diagram of influences of sabo/channel works on social aspect	110
Fig. 3.21	A Diagram of influences of sabo/channel works on economical aspect	111
Fig. 3.22	A Diagram of influences of sabo/channel works on environment	112
Fig. 3.23	Diagram of effect of sand mining activity on environment	114
Fig. 3.24	Diagram of effect of sand mining activity on social aspect	115
Fig. 3.25	Diagram of influences of sand mining on economic aspect	116
Fig. 3.26	Aspects to be considered in sediment management	117
Fig. 3.27	Unsustainable condition of sediment resources and safety aspects	118
Fig. 3.28	Sustainable condition of sediment resources and safety aspects	119
Fig. 3.29	Flow chart to determine the allowable sand mining volume	119
Fig. 3.30	Relationship between the designed slope and the sand mining volume	121
Fig. 3.31	Relationship between the designed slope and the allowable sediment supply	122
Fig. 3.32	Simulation conditions using uniform sediment	126
Fig. 3.33	Riverbed variation in Cases 1, 2a and 2b in a period of 10 years with uniform sediment	127
Fig. 3.34	Riverbed variation in Cases 3a and 3b in a period of 10 years with uniform sediment	128
Fig. 3.35	Initial longitudinal bed geometry	129
Fig. 3.36	Temporal change of bed geometry using uniform sediment	132

Fig. 3.37	Temporal change of sediment transport rate using uniform sediment	133
Fig. 3.38	Simulation conditions using non-uniform sediment	134
Fig. 3.39	Riverbed variation in Cases 1, 2a and 2b in a period of 10 years using non-uniform sediment	136
Fig. 3.40	Riverbed variation in Cases 3a and 3b in a period of 10 years using non-uniform sediment	137
Fig. 3.41	Relationship between sand mining volume and riverbed variation	137
Fig. 3.42	Temporal change of bed geometry using sediment mixture	138
Fig. 3.43	Temporal change of sediment transport rate using sediment mixture	141
Fig. 3.44	Temporal change of mean diameter with sediment mixture	142
Fig. 3.45	The variation of sediment production in a period from (a) 1930-1959 and (b) 1961-1990	143
Fig. 3.46	The location of lower Progo River from estuary to Krasak junction and the simulation cases	144
Fig. 3.47	Simulation results of Case A-1, (a) riverbed elevation changes (b) riverbed variation changes and (c) aggradation/degradation in the main structures	146
Fig. 3.48	Simulation results of Case A-2, (a) riverbed elevation changes (b) riverbed variation changes and (c) aggradation/degradation in the main structures	146
Fig. 3.49	(a) Estimation of potential sediment production, (b) Estimation of potential sediment discharge from Mount Merapi in period of 1930-1992	148
Fig. 3.50	The excess of sediment discharge from Mount Merapi	149
Fig. 3.51	The sediment discharge from Mount Merapi that must be captured by sabo works	150
Fig. 3.52	Cumulative of required volume of sabo works	151
Fig. 3.53	The location of Putih River and lower Progo River. The length of simulation is indicated by the red colour line	151
Fig. 3.54	Simulation conditions for cases without sabo works	153

Fig. 3.55	Simulation result on sediment discharge and bed variation in Case B-1 (without sabo works and no sand mining)	155
Fig. 3.56	Simulation result on sediment discharge and bed change with variation of sediment supply (without sabo works and no sand mining)	156
Fig. 3.57	Simulation result on sediment discharge and bed change with variation of sediment supply (without sabo works and sand mining (40%))	157
Fig. 3.58	Simulation result on sediment discharge and bed variation in Case B-2 (without sabo works and sand mining volume of 50% annual sediment production)	158
Fig. 3.59	Simulation result on sediment discharge and bed variation in Case B-3 (without sabo works and sand mining volume of 100% annual sediment production)	158
Fig. 3.60	Grain size distribution for Putih and Progo Rivers	159
Fig. 3.61	Simulation conditions for cases without sabo works	160
Fig. 3.62	Simulation result on sediment discharge and bed variation in Putih River in Case C-1 (with sabo works and no sand mining)	161
Fig. 3.63	Simulation result on sediment discharge and bed variation in Putih River in Case C-2 (with sabo works and sand mining volume of 50% annual sediment production)	161
Fig. 3.64	Simulation result on sediment discharge and bed variation in Putih River in Case C-3 (with sabo works and sand mining volume of 100% annual sediment production)	162
Fig. 3.65	Temporal sediment discharge due to variation of sediment supply in Putih River with no sand mining	163
Fig. 3.66	Temporal sediment discharge due to variation of sediment supply in Putih River with sand mining volume of 40% annual sediment production	164

Fig. 3.67	Temporal deposition in Putih River under installed sabo dams case combined with (a) no sand mining, (b) sand mining volume of 40% annual sediment production	164
Fig. 4.1	A diagram of impacts of sediment management on environment and socio-economic	169
Fig. 4.2	The directions of the impacts of sediment management on socio-economic and environment	172
Fig. 4.3	The expected results of proposed sediment management on (a) socio-economic, (b) utilization, safety and environment	172
Fig. 4.4	Impact of sediment management on loss of job opportunity	174
Fig. 4.5	Impact of sediment management on loss of tax income	177
Fig. 4.6	Impact of sediment management on socio-economic condition	177
Fig. 4.7	Sketch of a bridge	179
Fig. 4.8	Effect of sediment management on the parameters P_1 , P_2 , and P_3 ; and risk degree of the parameters P_1 , P_2 , and P_3 at 30 km from downstream boundary end	180
Fig. 4.9	Effect of sediment management on the parameters P1, P2, and P3; and risk degree of the parameters P1, P2, and P3 at 20 km from downstream boundary end	182
Fig. 4.10	Effect of sediment management on the parameters P_1 , P_2 , and P_3 ; and risk degree of the parameters P_1 , P_2 , and P_3 at 18 km from downstream boundary end	182
Fig. 4.11	Effect of sediment management on the parameters P1, P2, and P3; and risk degree of the parameters P1, P2, and P3 at 14 km from downstream boundary end	183
Fig. 4.12	Effect of sediment management on the parameters P_1 , P_2 , and P_3 ; and risk degree of the parameters P_1 , P_2 , and P_3 at 11 km from downstream boundary end	183
Fig. 4.13	Effect of sediment management on the parameters P_1 , P_2 , and P_3 ; and risk degree of the parameters P_1 , P_2 , and P_3 at 9 km from downstream boundary end	183

Fig. 4.14	Effect of sediment management on the parameters P_1 , P_2 , and P_3 ; and risk degree of the parameters P_1 , P_2 , and P_3 at 2 km from downstream boundary end	184
Fig. 4.15	Sketch of an irrigation intake	185
Fig. 4.16	Effect of sediment management on the parameters P_4 , and P_5 , and risk degree of the parameters P_4 , and P_5 at point 30 km from downstream boundary end	186
Fig. 4.17	Effect of sediment management on the parameters P_4 , and P_5 , and risk degree of the parameters P_4 , and P_5 at point 20 km from downstream boundary end	188
Fig. 4.18	Effect of sediment management on the parameters P_4 , and P_5 ; and risk degree of the parameters P_4 , and P_5 at point 18 km from downstream boundary end	188
Fig. 4.19	Effect of sediment management on the parameters P_4 , and P_5 ; and risk degree of the parameters P_4 , and P_5 at point 14 km from downstream boundary end	189
Fig. 4.20	Effect of sediment management on the parameters P_4 , and P_5 ; and risk degree of the parameters P_4 , and P_5 at point 11 km from downstream boundary end	189
Fig. 4.21	Effect of sediment management on the parameters P_4 , and P_5 ; and risk degree of the parameters P_4 , and P_5 at point 9 km from downstream boundary end	190
Fig. 4.22	Effect of sediment management on the parameters P_4 , and P_5 ; and risk degree of the parameters P_4 , and P_5 at point 2 km from downstream boundary end	190
Fig. 4.23	The riverbed material changes at the observed locations	193
Fig. 4.24	Effect of sediment management on risk degree of bridge foundation function (RP_1), utilization, and environment at point 30 km from downstream boundary end	195
Fig. 4.25	Effect of sediment management on risk degree of pier bridge function (RP_2), utilization, and environment at point 30 km from downstream boundary end	195

Fig. 4.26	Effect of sediment management on risk degree of bridge function (RP_3), utilization, and environment at point 30 km from downstream boundary end	195
Fig. 4.27	Effect of sediment management on risk degree of sedimentation (RP_4), utilization, and environment at point 30 km from downstream boundary end	196
Fig. 4.28	Effect of sediment management on risk degree of water intake function (RP_5), utilization, and environment at point 30 km from downstream boundary end	196
Fig. 4.29	Effect of sediment management on risk degree of foundation bridge function (RP_1), utilization, and environment at point 20 km from downstream boundary end	196
Fig. 4.30	Effect of sediment management on risk degree of pier bridge function (RP_2), utilization, and environment at point 20 km from downstream boundary end	197
Fig. 4.31	Effect of sediment management on risk degree of bridge function (RP_3), utilization, and environment at point 20 km from downstream boundary end	197
Fig. 4.32	Effect of sediment management on risk degree of sedimentation (RP_4), utilization, and environment at point 20 km from downstream boundary end	197
Fig. 4.33	Effect of sediment management on risk degree of water intake function (RP_5), utilization, and environment at point 20 km from downstream boundary end	198
Fig. 4.34	Effect of sediment management on risk degree of foundation bridge function (RP_1), utilization, and environment at point 18 km from downstream boundary end	198
Fig. 4.35	Effect of sediment management on risk degree of pier bridge function (RP_2), utilization, and environment at point 18 km from downstream boundary end	198

Fig. 4.36	Effect of sediment management on risk degree of bridge function (RP_3), utilization, and environment at point 18 km from downstream boundary end	199
Fig. 4.37	Effect of sediment management on risk degree of sedimentation (RP_4), utilization, and environment at point 18 km upstream from downstream boundary end	199
Fig. 4.38	Effect of sediment management on risk degree of water intake function (RP_5), utilization, and environment at point 18 km from downstream boundary end	199
Fig. 4.39	Effect of sediment management on risk degree of foundation bridge function (RP_1), utilization, and environment at point 14 km from downstream boundary end	200
Fig. 4.40	Effect of sediment management on risk degree of pier bridge function (RP_2), utilization, and environment at point 14 km from downstream boundary end	200
Fig. 4.41	Effect of sediment management on risk degree of bridge function (RP_3), utilization, and environment at point 14 km from downstream boundary end	200
Fig. 4.42	Effect of sediment management on risk degree of sedimentation (RP_4), utilization, and environment at point 14 km from downstream boundary end	201
Fig. 4.43	Effect of sediment management on risk degree of water intake function (RP_5), utilization, and environment at point 14 km from downstream boundary end	201
Fig. 4.44	Effect of sediment management on risk degree of foundation bridge function (RP_1), utilization, and environment at point 11 km from downstream boundary end	201
Fig. 4.45	Effect of sediment management on risk degree of pier bridge function (RP_2), utilization, and environment at point 11 km from downstream boundary end	202

Fig. 4.46	Effect of sediment management on risk degree of bridge function (RP_3), utilization, and environment at point 11km from downstream boundary end	202
Fig. 4.47	Effect of sediment management on risk degree of sedimentation (RP_4), utilization, and environment at point 11 km from downstream boundary end	202
Fig. 4.48	Effect of sediment management on risk degree of water intake function (RP_5), utilization, and environment at point 11 km from downstream boundary end	203
Fig. 4.49	Effect of sediment management on risk degree of foundation bridge function (RP_1), utilization, and environment at point 9 km from downstream boundary end	203
Fig. 4.50	Effect of sediment management on risk degree of pier bridge function (RP_2), utilization, and environment at point 9 km from downstream boundary end	203
Fig. 4.51	Effect of sediment management on risk degree of bridge function (RP_3), utilization, and environment at point 9km from downstream boundary end	204
Fig. 4.52	Effect of sediment management on risk degree of sedimentation (RP_4), utilization, and environment at point 9 km from downstream boundary end	204
Fig. 4.53	Effect of sediment management on risk degree of water intake function (RP_5), utilization, and environment at point 9 km from downstream boundary end	204
Fig. 4.54	Effect of sediment management on risk degree of foundation bridge function (RP_1), utilization, and environment at point 2 km from downstream boundary end	205
Fig. 4.55	Effect of sediment management on risk degree of pier bridge function (RP_2), utilization, and environment at point 2 km from downstream boundary end	205

Fig. 4.56	Effect of sediment management on risk degree of bridge function (RP_3), utilization, and environment at point 2km from downstream boundary end	205
Fig. 4.57	Effect of sediment management on risk degree of sedimentation (RP_4), utilization, and environment at point 2km from downstream boundary end	206
Fig. 4.58	Effect of sediment management on risk degree of water intake function (RP_5), utilization, and environment at point 2 km from downstream boundary end	206
Fig. 4.59	(a) Present conditions of environment, utilization and safety aspects. (b). Preferable conditions of the three aspects by sediment management	207
Fig. 4.60	Sketch of the experimental flume test	209
Fig. 4.61	(a) The flume and (b) grain size distribution used in the experiment	209
Fig. 4.62	Experiment results on bed surface and water surface in Run 1, Run 2, and Run 3	217
Fig. 4.63	Grain size distributions of surface bed material at the upstream ($x = 1\text{m}$), the middle stream($x = 3.5\text{ m}$) and the downstream ($x = 6\text{ m}$) after Run 1	218
Fig. 4.64	Grain size distributions of surface bed material at the upstream ($x = 1\text{m}$), the midstream($x = 3.5\text{ m}$) and the downstream ($x = 6\text{ m}$) after Run 2	220
Fig. 4.65	Grain size distributions of surface bed material at the upstream ($x = 1\text{m}$), the midstream($x = 3.5\text{ m}$) and the downstream ($x = 6\text{ m}$) after Run 3	221
Fig. 4.66	Experimental and simulation results on bed surface and water surface	224
Fig. 4.67	Experiment and simulation results on grain size distributions of surface bed material after Run 1	225
Fig. 4.68	Experiment and simulation results on grain size distributions of surface bed material after Run 2	226
Fig. 4.69	Experiment and simulation results on grain size distributions of	

surface bed material after Run 3

227

List of Photos

Photo 1.1 Conditions of Gendol River and its surrounding after a pyroclastic flow of the 2006 eruption (Photo (a) and (b) courtesy Adhy Kurniawan, Photo (c) courtesy Yoda Karya)	19
Photo 1.2 Kemiri Bridge on Boyong River after a debris flow in 1994 (Photo courtesy Adhy Kurniawan)	19
Photo 1.3 Damages at Kemiri Bridge on Boyong River in 1994 caused by a debris flow (Photo courtesy Adhy Kurniawan)	20
Photo 1.4 A sand mining activity (a) by local people in Gendol River (GE D1), (b) by a company nearby Woro R. (Photo (b) courtesy M.Thosan.P)	21
Photo 2.1 The interview of the survey	30
Photo 2.2 (a) The settled down piers and (b) the constructed new bridge. The both photos were taken in December 2008 (Source: Google Earth, 2010)	68
Photo 2.3 (a) The Bridges in Bantar and (b) a foundation is exposed by the riverbed degradation. The photos were taken in December 2008 (Source: Google earth, 2010)	69
Photo 2.4 The Kebon Agung Bridge. The foundation is exposed by the riverbed degradation. The photo was taken in December 2008 (Source: Google earth, 2010)	70
Photo 2.5 The Saphon irrigation intake. The photo shows the water cannot enter to the irrigation intake due to severe bed degradation (Photo courtesy Masaharu Fujita)	71
Photo 2.6 Impacts of riverbed degradation due to sand mining activity in the downstream of Opak River. Photos a, b, c was taken in June 2007. (Figure d source from Google earth, 2010)	72
Photo 3.1 A pyroclastic flow accompanied by glowing cloud after the 1984 eruption (Photo courtesy Adhy Kurniawan)	83
Photo 3.2 (a) Damages at a village on Krasak River after a debris flow in 1969, (b) Damages on houses in a village near Krasak River after a debris flow in 1976, and (c) A bridge condition on Putih River after a debris flow in 1984 (Photo courtesy Adhy Kurniawan)	87
Photo 3.3 Existing of sabo works on slopes of Mount Merapi	92

Photo 3.4 Sand mining activities on the foothills of Mount Merapi. Photo (a) shows the sand mining activity in Gendol River. Photo (b) shows the sand mining activity in nearby Woro River. (Photo (a) courtesy Haryono Utomo)	96
Photo 4.1 (a) A sand mining activity on Gendol River, (b) artificial armoring caused by sand mining activities	170
Photo 4.2 Sediment feeder	211
Photo 4.3 Final condition of the channel bed surface after Run 1, Run 2 and Run 3 at upper, middle and lower streams	219

List of Tables

Table 1.1	Ranking of major natural disasters by number of deaths reported by EM-DAT, 2003	4
Table 1.2	Quantifying the impacts of volcanic phenomena during the 20th Century	5
Table 1.3	Countries registering ten or more volcanic incidents in the 20th Century	5
Table 2.1	Distribution of the survey location	34
Table 2.2	Summarized conditions of the survey location	35
Table 2.3	Respondent distribution based on the survey location	36
Table 2.4	Respondent distribution based on the age of respondent	36
Table 2.5	Administrative unit in the study area	52
Table 2.6	River systems in Mount Merapi basin	63
Table 2.7	Riverbed fluctuation at the existing river structure	67
Table 3.1	Historical eruptions of Mount Merapi	78
Table 3.2	Sediment amount produced by pyroclastic flows	84
Table 3.3	Damages and casualties caused by pyroclastic flows	85
Table 3.4	Lahar related disaster at Mount Merapi	88
Table 3.5	Number of population in hazard zone	90
Table 3.6	Existing of sabo works in Mount Merapi	92
Table 3.7	Scenarios of sediment management	125
Table 3.8	Declining rate of potential of sediment production caused by an eruption	147
Table 3.9	Simulation conditions in the case of without sabo works	152
Table 3.10	Simulation conditions in the case of with sabo works	159
Table 4.1	Option and consequences for dealing with sediment related disasters	171
Table 4.2	Total loss of daily income of inhabitants	174
Table 4.3	Total loss of daily income of driver/co driver	175
Table 4.4	Conditions for experimental runs	210

Curriculum Vitae

Name IKHSAN JAZAUL

Citizenship Indonesia

Birth/Place May 24, 1972, Yogyakarta, Indonesia

Ph.D. Student (2007 - 2010)

Department of Civil and Earth Resources Engineering,
Graduate School of Engineering, Kyoto University, Japan

M.Eng. in Hydraulic Engineering (1999-2003)

Department of Civil and Environmental Engineering,
Graduate Studies Program Gadjah Mada University, Yogyakarta, Indonesia

B.E. in Civil Engineering (1992-1998)

Department of Civil Engineering and Environmental Engineering,
Faculty of Engineering, Gadjah Mada University, Yogyakarta, Indonesia

Papers based on the Thesis

Ikhsan, J., Fujita, M., and Takebayashi, H.: Study on sediment disaster and resources management in Mount Merapi area, *Proceeding of Annual Meeting of Japan Society of Civil Engineers*, JSCE, pp. 497-498, September, 2010.

Ikhsan, J., Fujita, M., and Takebayashi, H.: Sediment disaster and resource management in the Mount Merapi area, Indonesia, *International Journal of Erosion Control Engineering*, Vol.3, No.1, 2010.

Ikhsan, J., Fujita, M., and Takebayashi, H.: Impacts of sediment management on socio-economic and environment in Mt. Merapi area, *Proceeding of Annual Meeting of Japan Society of Erosion Control Engineering*, JSECE Publication No.57, pp. 472-473, May, 2010.

Fujita, M., Ikhsan, J., and Takebayashi, H.: Impacts of sediment management on socio-economics and environment in Mt. Merapi area, *Proceeding of International Workshop on Multimodal Sediment Disasters Triggered by Heavy Rainfall and Earthquake and the Countermeasures*, pp. 87-96, March, 2010.

Ikhsan, J., Fujita, M., and Takebayashi, H.: Study on sediment management in volcanic area by considering disasters mitigation and resources management, *Proceeding of International Workshop on Multimodal Sediment Disasters Triggered by Heavy Rainfall and Earthquake and the Countermeasures*, pp. 67-76, March, 2010.

Ikhsan, J., Fujita, M., and Takebayashi, H.: Sediment disasters and sediment resources managements in Mount Merapi area, *Proceeding of Asia-Pacific Symposium on New Technologies for Prediction and Mitigation of Sediment Disasters*, JSECE Publication No. 55, pp. 106-107, November, 2009.

Ikhsan, J., Fujita, M., and Takebayashi, H.: Sustainable sand mining management in Merapi area using groundsills, *Annals of the Disaster Prevention Research Institute*, Kyoto University, No.52B, pp. 647-657, June, 2009.

Ikhsan, J., Fujita, M., and Takebayashi, H.: Sand mining impacts on socio-economic inhabitant and river bed variation in Merapi area, *Proceeding of Annual Meeting of Japan Society of Erosion Control Engineering*, JSECE Publication No.52, pp. 50-51, May, 2009.

Ikhsan, J., Fujita, M., Takebayashi, H. and Sulaiman, M.: Concepts on sustainable sand mining management in Merapi area, *Annual Journal of Hydraulic Engineering*, JSCE, Vol.53,pp. 151-156, February, 2009.

Ikhsan, J., Sulaiman, M., and Fujita, M.: A study on sustainable sediment management in Merapi volcanic area, *Proceeding of Fourth International Conference on Scour and Erosion (ISCE-4)*, pp. 553-557, November 2008.

Ikhsan, J., Sulaiman, M., and Fujita, M.: Study on sustainable sand mining management in Merapi volcanic region, *Proceeding of Annual Meeting of Japan Society of Erosion Control Engineering*, JSECE Publication No.50, pp. 338-339, May, 2008.