

A STUDY ON COMPUTER METHODS IN DESIGN
AND FABRICATION OF STEEL STRUCTURES

A STUDY ON COMPUTER METHODS IN DESIGN
AND FABRICATION OF STEEL STRUCTURES

BY

TATSUMASA TAKAKU

August, 1976

ACKNOWLEDGMENT

The author wishes to express his sincere thanks to several persons who have supported him during his study and work, for their enthusiasm, encouragement, and guidance.

He is grateful to his graduate advisor, Professor Y. Yamada of Kyoto University, for his instruction and enlightenment during the period of matriculation and even after graduation.

The original motivation of his interest in the specification organization and in constraints processing was in the discussion in the Optimum Design Group of the Kansai Highway Road Research Committee, which was directed by Professor Yamada. The author wishes to thank I. Konishi, Professor Emeritus of Civil Engineering at Kyoto University, for his instruction about structural engineering.

The author is especially indebted to his graduate advisor, Professor L. A. Lopez of the University of Illinois at Urbana-Champaign, for his guidance during the course of his investigation, especially for his many suggestions about constraints processing. He is also grateful to Professor J. W. Melin of the University of Illinois for his kind suggestions about specifications organization.

Finally, the author is most grateful to many staffs in Nippon Kokan K.K., with whom he was able to develop the new N/C system there.

ABSTRACT

A study on computer methods of design and fabrication of steel structures has been conducted to match the requirements on the production works from a fabricator view point. First, the study deals with constraints processing as a part of computer aided design (CAD) after discussing the organization methods of the specifications which exist as the constraints in design environments. Second, the numerical control system (N/C System) in the yards is discussed, which is applicable to the fabrication works both of bridges and building frames. Finally, a total system which covers the entire procedures of production works in design through fabrication is proposed.

The first part of the study associated with CAD which contains organization of specifications and constraints processing has been conducted when the author was a graduate student at the University of Illinois at Urbana-champaign from 1970 to 1971.

The last part of the study associated with the N/C system is a part of results of the N/C Project which has been developed in Nippon Kokan K.K. during recent several years.

TABLE OF CONTENTS

CHAPTER	Page
I. ORGANIZATION OF SPECIFICATIONS	1
1.1 General Views	1
1.1.1 Introduction	1
1.1.1.1 Forms of Specifications and Their Use	1
1.1.1.2 Requirements of Specifications	1
1.1.1.3 Levels of Textual Presentation	2
1.1.2 Decision Table and Application	3
1.1.2.1 Decision Table	3
1.1.2.2 Use for Review of Provisions in Specifications	4
1.1.2.3 Checking Approach and Design Approach	5
1.1.3 Network and Application	6
1.1.3.1 Network	6
1.1.3.2 Application to Specifications	6
1.1.4 Organization of Specifications	8
1.1.5 Previous Work	9
1.2 Design Configuration	11
1.2.1 Outline	11
1.2.2 Facility	12
1.2.3 Environment	13
1.2.4 Interaction	13
1.2.5 Performance	14
1.3 Analysis and Organization of the Specifications	15
1.3.1 Organization of the AISC and ACI	15
1.3.2 Analysis and Organization of the Lateral Force Code	16
1.3.2.1 Analysis	16
1.3.2.2 Revised Organization	17
1.3.3 Levels of Specifications	18
1.4 Generation Method of Specifications Text	19
1.4.1 Organization of Outline	19
1.4.2 Description of Provisions	20
1.4.3 Network Expression	22
1.5 Summary and Conclusion	22
II. CONSTRAINTS PROCESSING	24
2.1 Background	24
2.1.1 Outline	24
2.1.2 Design Procedures	24
2.1.3 Terminology	25
2.1.3.1 Constraint and Design Criteria	25
2.1.3.2 Attributes and Parameters	25
2.1.3.3 Ingredients and Dependents	26
2.1.3.4 Sets and Subsets	26

	Page
2.1.4 Execution of Network	26
2.1.4.1 SEEK and WARN Modes	26
2.1.4.2 Stack Technique	27
2.1.4.3 Recycling Operation	27
2.1.5 Organization of Provisions	28
2.1.5.1 Provisions in Specification	28
2.1.5.2 Provisions in Network	29
2.2 Application of Conformance Checking to a Truss Bridge	30
2.2.1 Task	30
2.2.2 Outline of the Specification	30
2.2.3 Networks of Tension and Compression Member Criteria	31
2.2.4 Attributes and Parameters Lists	31
2.2.5 Decision Table Expression	31
2.2.6 Evaluation	32
2.2.6.1 Tension Member Check	32
2.2.6.2 Compression Member Check	32
2.3 A Model of Constraints Processing	33
2.3.1 Outline	33
2.3.2 Network Linkage Editor	34
2.3.2.1 Capability	34
2.3.2.2 Internal Form of Network	34
2.3.2.3 Outline Index Library	35
2.3.3 Data Manager	36
2.3.3.1 Capability	36
2.3.3.2 Parameter Library	37
2.3.4 Executor	38
2.3.4.1 Capability	38
2.3.4.2 Input Interpreter	38
2.3.4.3 Function Program	39
2.3.4.4 Execution	39
2.4 Summary and Conclusion	40
III. NUMERICAL CONTROL SYSTEM IN FABRICATION	42
3.1 General Views	42
3.1.1 Background	42
3.1.2 Outline	45
3.2 N/C System in Bridge (BRISTLAN System)	49
3.2.1 Conventional Flow of Work	49
3.2.2 Environments in System Design	49
3.2.3 Outline of BRISTLAN System	52
3.2.4 Subprogram and Macro Library	54
3.2.5 Secondary Data (SD)	55
3.2.6 BRISTLAN LANGUAGE and Capability	56
3.2.6.1 Statements	56
3.2.6.2 Basic Elements of Figures	57
3.2.6.3 Expression of Figures	58
3.2.6.4 Classification of Statements	60

	Page
3.2.7 Internal Expression of Figures (Segment Lists)	60
3.2.8 Configuration of Processors	62
3.2.8.1 Compiler Processor	63
3.2.8.2 Linkage Editor Processor	63
3.2.8.3 Figure Processor	63
3.2.8.4 Postprocessors and N/C Machine Information	64
3.2.9 Application to Bridge and Coding Examples	65
3.2.10 Revised BRISTLAN System	67
3.2.11 Effects and Conclusions	69
3.3 N/C System in Building Frame	71
3.3.1 Environments	72
3.3.2 System Flow	74
3.3.3 Organization of Structural Members	74
3.3.4 Fabrication Flow	75
3.3.5 Material Handling	77
3.3.6 Coordinates Handling	77
3.3.7 Section Handling and BRISTLAN 2	79
3.3.8 Effects and Conclusions	79
3.4 Future and Proposed Scheme	81
3.4.1 Information Flow in Design and Fabrication	81
3.4.2 Fabrication Network	82
3.4.3 Data Communication	83
3.4.4 Response to Data Change	84
IV SUMMARY AND CONCLUSIONS	86
REFERENCES	91
TABLES	94
FIGURES	132
VITA	190

GLOSSARY

[Section I]

Algorithm -- explicitly defined procedure

Boolean (or logical) data -- variable that may have the value "Yes" or "No"

Decision table -- an explicit logical procedure in tabular form that indicates
action to be taken for particular combinations of known conditions

Intermediate level organization -- organization of the provisions in functional
network of a design criterion or criteria

Limit state -- mode of unsatisfactory behavior (yield, instability, etc.)

Network -- graphical representation of a data structure; system of nodes
interconnected by branches

Organization -- overall outline for the Specification

Stress state -- type of stress (tension, shear, etc.)

Top-level organization -- overall organization of the Specification

Facility -- structures or components of structures in the design configuration

Environment -- circumstances where the Facility exists (external loads,
atmosphere, etc.)

Interaction -- responses or behavior of the Facility under the Environment
(structural analysis, ...)

Performance -- safety and serviceability of the Facility

[Section II]

Conditional execution -- execution procedure where the highest (output) level criteria are processed first and lower level provisions are introduced when needed

Direct execution -- execution procedure where lower level provisions are processed before higher-level provisions referring to them, so that all data are defined before their first use.

Dependents -- data whose values are affected by the value of the data item

Ingredients -- data used to evaluate the data item

Criterion -- functional relationship intended to provide an adequate margin of safety with respect to a particular mode of failure

SEEK mode -- an execution type of the network from the highest node

WARN mode -- an execution type of the network from the lowest node

FLAG -- represents the values of the node in the network void or valid

Stack -- a mechanism for storing information and retrieving it using the Last-IN-FIRST-OUT principle

Recycling operation -- repeated execution within a network

Interpreter -- scans the input data and interprets it

[Section III]

- N/C -- Numerical Control. Machine tool is operated under control of numerical information.
- Part programming -- Programming job to make input data to N/C machine either in tabulated form or in language.
- Postprocessor -- A computer program which accepts part-oriented information representing the tool located on the part and converts it to a machine acceptable form.
- Preprocessor -- A computer program which generates coordinate data necessary to figure processing.
- Flame cutter -- A N/C gas cutter with multiple torches, especially for cutting along lines with relatively large curvature.
- EPM -- Electronic Photo Marking Machine which enlarges original films from 1/10 scale to full scale and prints them onto steel plate.
- BRISTLAN -- Bridge and Steel Structure Lofting Language developed in NKK.
- MACRO -- A set of instructions like ASSEMBLER MACRO, sometimes used as a subroutine in a wider sense.
- PD -- Primary Data
- SD -- Secondary Data
- TD Third (Tertiary) Data
- CAD -- Computer Aided Design
- ROAD -- Road Program. A subsystem program in BRISTLAN system.
- BRMESH -- BRIDGE MESH. A subsystem program in BRISTLAN system.
- MRG -- Material Report Generator

- SDPC -- Secondary Data Production Commands
- POLO -- Problem Oriented Language Organizer developed at University of Illinois.
- Design drawings -- A variety of drawings performed in design section, such as profile, side, and plane drawings. They give descriptive information about the major components of the facility.
- Fabrication drawings -- Based on design drawings, they are intended to supply sufficient information so that fabrication can be performed directly. They contain all design data fully detailed and dimensioned.
- Shop drawings -- Sketches of parts, components, and connections in detail for shop operations. Due to differences in methods and procedures of various fabricators, shop drawings may vary in appearance.
- Template shop operations -- Copying shop drawings to manuscripts or information for cutting and assembling in fabrication. In a wider sense, this sometimes includes shop drawings.

I. ORGANIZATION OF SPECIFICATIONS

1.1 General Views

1.1.1 Introduction

1.1.1.1 Forms of Specifications and Their Use

When we think of a specification in terms of its written form, three forms appear to have considerable value for different uses:

- A) an abstract form, in graphical or tabular format, which may be useful for rapid comparison of different codes for similarities, differences, omissions, or overlaps.
- B) a textual form for normal expression and use.
- C) a computer-processable form for generating computer programs.

In connection with B), it is to be noted that a specification may have several alternate textual forms, intended for different use. For instance, a specification for structural design may have different textual forms for:

1. the reviewer for the building regulator agency determining whether a given design meets the applicable codes and standards.
2. the designer developing a design meeting the functional needs and the specifications.
3. the student learning how structures behave and how the specification assures that the intended behavior is achieved.

1.1.1.2 Requirements of Specifications

In order for a specification to satisfy the intent of its writers, it must have the following three properties:

- A) Completeness, that is, it must explicitly apply in any possible situation. All pertinent bases are identified and lead to the applicable criteria.

- B) Uniqueness, that is, it must yield one and only one outcome in any possible situation. A given set of bases always leads to the same criteria.
- C) Correctness, that is, it must yield the outcome intended by the specification writers. A given set of bases leads to the right criteria.

The detailed hierarchical sequence for the evaluation of a criterion must again provide for:

- A) All possible situations in which the criterion is applicable (Completeness).
- B) One value of the criterion for all possible values of the parameters (Uniqueness).
- C) The right value of the criterion (Correctness).

In a computer sense, A) and B) are concerned with syntax check, whereas C) is concerned with semantic check.

1.1.1.3 Levels of Textual Presentation

A specification consists of a collection of design criteria along with a hierarchical sequence of computations, checks, formulas, limits, etc., and can be represented independently of its textual representation by a graph or logical network. The grouping and ordering of the criteria in the specification may be represented by a second, or organizational network so as to provide a logical and consistent entry to the various criteria which must be evaluated according to the specification.

The format of the text of a specification must be viewed at three levels¹⁾:

1. Top level (Organizational level)

- 2. Intermediate level (Network level)
- 3. Detailed level (Provision level, Decision Table level)

The top level provides the overall organization of the text by hierarchically structuring independent bases for grouping the design criteria. The intermediate level provides for organization of the functional network used in evaluation of a particular criterion or a set of criteria. The functional network can be organized for conditional or direct execution. Detailed level organization of specific sections or paragraphs of the text can be obtained by organizing individual decision tables for delayed decision or immediate decision logic.²⁾

1.1.2 Decision Table and Application

1.1.2.1 Decision Table

A decision logic table is a concise tabular display of the logical conditions applicable in a given situation and of the appropriate actions to be taken as a result of fulfilling or not fulfilling the conditions. A decision table consists of four parts:

Condition Stub	Condition Entry
Action Stub	Action Entry

Figs. 1-1(a) and (b) show examples of decision tables, in which symbols are used according to the following convention:

- T : True (Yes)
- F : False (No)
- + : Explicitly True (In rule (1) of Fig. 1(a), if $A > B$ and $B > C$, then obviously $A > C$)

- : Explicitly False (In rule (3) of Fig. 1(a), if $A > B$ and $A < C$, then obviously $B > C$ is false)
- I : Immaterial (True or False)

Figs. 1-1(c) and (d) show the derived decision networks which represent the execution procedure to reach each rule. This flow clarifies the completeness and uniqueness of the conditions. ER (Else rule) in Fig. 1-1(c) indicates contradiction or redundancy of the original table. Therefore, table (b) is complete, and its rules are unique.

The derived decision network is a result of conversion of a decision table to a set of two-way decisions, known as decomposition. There are two ways to decompose.²⁾ One way is the "quick rule" of which the objective is to perform tests as soon as possible. This results in the shortest program (min IF). Another way is the "delayed rule" of which the objective is to delay tests as long as possible. This results in reducing the running time of the program. The conventions, +, -, I, are very useful not only in reducing the total number of rules in a decision table, but also in reducing the number of decompositions.

1.1.2.2 Use for Review of Provisions in Specifications

The decision table is very useful for review of provisions in specifications at the detailed level. A few decision tables based on the provisions of the Lateral Force Code (LFC)³⁾ are shown in Table 1-1, in which the symbols at the stubs represent the data name. In the given cases, the decision tables are not independent of the others. In other words, the outcomes in the action stub become the input to the upper level decision tables. Those relationships are represented by another higher level hierarchy of the network.

Table 1-2(a) prescribes a paragraph provision in the LFC, and the corresponding decision table is shown in Table 1-2(b).

The revised and reorganized decision table is shown in Table 1-2(c) in a compact form of rules. Based on this revision, the corresponding revised textual expression is proposed in Table 1-2(d). The revised one is clearer than the original.

1.1.2.3 Checking Approach and Design Approach

There are two kinds of approaches for the use of the decision table: one is the checking approach, the other is the design approach. In a checking approach of the evaluation of specifications, all data are contained in the condition stub. The result of the table is either "satisfactory" or "violated". This checking system makes criteria of the provisions in the code. The action stub question changes from: "Is the value acceptable?" to "Under the stated conditions, what is the design value?" when we change it from the checking approach to the design approach. In the previous examples of the decision tables, Fig. 1-1 corresponds to the design approach, whereas Table 1-1 corresponds to the checking approach.

The major difference between these two approaches is that the checking approach results in boolean data and the design approach in numerical values. The action stub of the design table usually consists of more than two items as a result of combination of conditions, whereas in the checking approach it is limited to two items of boolean data although there may have been more than two in the early work.⁴⁾ In the case of the design approach, more than two action entries make for more complicated and quite different hierarchical networks of decision tables than in the case of the checking approach.

1.1.3 Network and Application

1.1.3.1 Network

According to graph theory, a network is considered to be a graph; the junction points are nodes and the lines connecting nodes are branches, in which a flow between connected nodes exists. Most civil engineering problems, when idealized, form networks of junction points interconnected by branches. Table 1-3 shows some examples indicating the significance of branches and nodes in civil engineering systems.

The significant feature of a network is that incidences or connectivity relations represented by the graph impose algebraic relations on the variables describing the behavior of individual elements. A cycle is a chain connecting a node to itself (Mesh or Loop). A connected graph is a graph in which there exists a chain connecting them for every pair of nodes. A tree is a connected graph containing no cycles.

1.1.3.2 Application to Specifications

Interrelationship among provisions and variables in the specifications builds a sort of network, in which branches correspond to procedures of execution and nodes to provisions or variables.

Each node is connected by a branch to each of its ingredients, which are defined as all of the nodes that may be required to evaluate it. The branch is a directed branch, pointing from the ingredient to the node. The node can be said to be dependent on each of the ingredient nodes, although it may not be the only dependent. The network of specifications builds a "Tree" structure, in which their relationship is not "Loop". Fig. 1-2(a) shows a general form of network. Fig. 1-2(b) represents an application to a specification network whose provisions are derived from

Table 1-1. Fig. 1-2(c) demonstrates a conventional expression of the network which is commonly used for computer analysis.

Directed branches (arrows) indicate the computational steps of the procedure. There are two strategies or approaches possible for executing a hierarchy of a network, where the nodes make reference to data elements identified as obtainable from lower level nodes. The two available strategies are:

1. "Direct execution", in which the sequence of execution is arranged a priori so that the values of all undefined data elements are obtained by executing the associated nodes first.

For instance, in Fig. 1-2(b), the lowest node's data, such as BWELD, BEDLEL, etc., should be defined prior to the execution of decision tables T11, T111 and so on.

2. "Conditional execution", in which execution of a table is initiated even though one or more of the required data elements may not be defined. As soon as an undefined element is encountered, execution of the node currently under processing is temporarily suspended and proceeds to the lower level nodes until the data available is found. After finding satisfactory data, execution of the original node is then resumed.

For instance, in Fig. 1-2(b), execution starts from the topmost node T10, then proceeds to T111 through T1D1. The advantage of this procedure is that once each node is executed and defined, the next recycling operation is not required again except at the nodes where the data is changed. For example, in Fig. 1-2(b), if data BELEM is changed, then only T1D1 and T10 will be executed again, without executing T11 and T111. This feature is very significant for design procedure as detailed below.

1.1.4 Organization of Specifications

The system of organization referred to as an outline serves to provide access to the proper provisions of a specification that will apply in any given situation. The scope of the specification is described by headings (arguments) and the table of contents lists the provisions in a linear sequence (page number, section, chapter or paragraph, etc.) according to their relation to the arguments. The organization is essentially unrelated to that of the information network; it shows very clearly how the arguments are used to identify the applicable provision. The details of the system have not been made as clear as those of the decision table and network because of the limited investigation so far.

In 1973, Nyman, Fenves, and Wright¹⁾ tried to organize the AISC Specification by setting up tentative triplets as the basic arguments: limit states, stress states, and physical components. Table 1-4 shows the classification of the AISC on the basis of the triplets. For example, the term global instability refers to member instability, which includes Euler buckling in columns or lateral-torsional instability in beams, whereas local instability refers to buckling of flanges or webs at a localized point along a member. In other words, limit states cover every possibility of failure modes of steel structural members. Physical components and stress states probably cover every type of structural element and every type of force existing in members respectively. The combination of these major arguments organizes the scheme of provisions in the specification. Table 1-5 demonstrates a part of the organization in terms of ordering of each triplet.¹⁾ There are many interesting facts in it:

1. There are numerous cases where more than one provision is associated with a triplet. Besides, there are cases where a provision

is associated with several different triplets (Table 1-5(a),(b)).

2. Many of the design criteria cannot be uniquely defined by a single triplet.

3. The change of ordering of triplets yields the change of number of redundancy; the less redundancy, the better the organization.

4. A satisfactory top level organization of the specification should provide that each design criterion is uniquely associated with one triplet and that a single triplet apply to only one particular design criterion. Reorganization of provisions satisfies such a requirement (Table 1-5(c)).

5. Each design criterion could be uniquely tagged with a single triplet, which means that the design criteria are independent of one another.

1.1.5 Previous Work

The technology of the proposed investigation had its beginning with the development of decision table logic in the 1950's to assist in the development of the logic of computer programs. Pollack²⁾ describes the history in detail with extensive references. Fenves⁵⁾ identified the applicability of this concept to design specifications of the procedural type; with Gaylord and Goel⁴⁾ he investigated the expression of the AISC Specification in decision table form, and observed that the data or information content of the Specification is topologically related in the form of a hierarchical network. In the study, they used three kinds of figures; tree chart (a kind of network), decision table, and cross reference table. It should be noted that three different kinds of decision tables produced different types of results for different purposes; in other words, both checking and design approaches had been conducted. At almost the same time, Wright, Boyer, and Melin⁶⁾ were independently studying the formulation and processing of constraints

in computer-aided design programs. They recognized that the topological network relationship of the data, connecting the top level design criteria to the input design variables at the lowest level, provided a key to the efficient operation of the resulting programs. Not only would the evaluation of the design criteria, descending through many stages to the values of the input design variables, be self-programming, but in operation the resulting programs would make only the minimum number of essential computations. An implementation of this approach was presented by Fenves.⁴⁾

The information content of a specification has two parts: an organization leading to the applicable criteria, and a network representing the interrelationships between the provisions needed to evaluate the criteria. The provisions themselves may, in general, be expressed by decision tables. Fenves and Wright led an investigation of the application of this technology to the restructuring of the AISC Specification.¹⁾

In further extending this work, Nyman and Fenves⁹⁾ explored algorithms and computer aids for outlining the information content of the specification and the textual expression of decision table logic. They made clear the three basic levels of strategies for analyzing specifications, that is, provision level, network level, and organization level. At each level, semantic and syntax check can be established. Based on this conception, three levels of programs, "Decision Table Program", "Information Network Program", and "Outline Program", have been completed for general analysis by Wright, Harris, Melin, and Albarran⁸⁾ in 1975. The three level formalized procedures for developing and using a specification are briefly tabulated in Table 1-b in terms of representation, analysis, and expression. The basic procedures of the analysis in the above three independent programs are based on the

summarized analysis technique described in that Table.

Based on the report by Gaylord and Goel⁴⁾, the same sort of work was conducted by Yamada and Takaku⁹⁾ in Japan in 1973. They applied the same conception to the Specification of Highway Road Bridges in Japan.¹⁰⁾

The original format of the decision table is designed either for the checking approach or for the design approach. This capability has led to two major branches in the development of technology, one to the technology for the formulation and expression of specifications, another to the application to the design fields. The emphasis of the study conducted ever since has been supposedly put on the former side, although the network strategy is capable of being used easily in the design fields.

1.2 Design Configuration

1.2.1 Outline

When we design a structure, we assume the geometry and properties of structure and external loads in a given circumstance, and then analyze the structure either by hand or by computer. Sizing of components may or may not be revised iteratively until it satisfies the constraints surrounding the structure.

This normal design procedure can be expanded to the more general design configuration in a compact form as shown in Fig. 1-3. The design configuration consists of the four major components; "Facility", "Environment", "Interaction", and "Performance", in which performance is considered to be the outcome of interaction between a facility and an environment. Consequently, those four basic items build the major arguments of design criteria. Table 1-7 shows the basic arguments and their sub-arguments which are applicable to any type of design configuration

for general use even though they are limited to steel structures.

1.2.2 Facility

"Facility" covers every kind of structure and equipment, from a huge building down to a small element of a structure such as a lock attached to a door. It falls into five categories:

- A. Classification for Entity
- B. Classification for Environment
- C. Classification for Interaction
- D. Classification for Performance
- E. Classification for Fabrication and Construction

The sub-arguments for each item are tabulated in Table 1-7.

A) is concerned with serviceability, which is deeply related to the human activity and safety. In this category, physical entity is due to structural safety required against external hazards, and mechanical entity is due to human activity and protection against internal hazards. For instance, the shear wall of a building exists for structural safety, whereas the elevator exists for human activity.

B) is concerned with the resistance mechanism of the structure. Each member and each element of the members play an individual role for each particular purpose of existence. For instance, a base plate and a connection bolt exist for different purposes.

C) is concerned with the geometry and property of structures. It includes dimensions (sizes or coordinates), member properties, and boundary conditions, which are usually required as input data for the analysis program.

D) is concerned with design details. For example, members, elements of members, connectors, and connections are the sub-arguments of this category, which arises from the AISC.

E) is concerned with assembling of structures in yards and at construction sites. This category is very significant for fabrication in yards when the jobs move from the design process to the shop working process. The details are described in Section III.

1.2.3 Environment

"Environment" specifies the circumstances or situation, considering the particularity or locality where the structure exists. It falls into six categories:

- A. External loads
- B. Atmosphere
- C. Geography
- D. Foundation and Sub-structure
- E. Significance
- F. Internal hazards

Each item is deeply related to the failure modes of structures. For example, brittle fracture is very sensitive to low temperature of the atmosphere. Most of the specifications are concerned with the criteria of the environment. Since the environment is a matter of natural science, it accurately reflects the development of its study as well as engineering technology, based on the reliability and safety of the structures.

1.2.4 Interaction

"Interaction" is defined as the behavior or response of the structure under given circumstances. In a wider sense, interaction problems are associated with structural mechanics (or fracture mechanics), which deals with static or dynamic behavior of structures subjected to external loads, based on the corresponding failure modes. In a restricted sense,

conventional structural analysis has formerly implied solution of interaction problems. Interaction falls into three categories:

- A. Failure mode
- B. Philosophy
- C. Modeling

Originally, interaction is associated with mathematics or physics rather than engineering technology. Mathematical modeling is a significant technique for solving mathematical problems such as equilibrium problems, eigenvalue problems, or propagation problems, based on the engineering properties of the structures as well as the environment. The development of the technology in this field is closely related to how accurate the solution of the behavior is and how close to the real behavior it is. Therefore, it has strongly reflected the development of computer analysis. Specification always stands on a conservative assumption which is able to absorb uncertainties of design procedures and this attitude sometimes leads to revision of articles according to the progress of new technology.

1.2.5 Performance

As a result of interaction between "facility" and "environment", "performance" is generated as the engineering problems. Performance has four basic sub-arguments:

- A. Global stability
- B. Stress states
- C. Safety
- D. Serviceability

A) involves structural stability such as overturning, lateral torsional buckling of a beam or aerodynamic stability due to wind. B) classifies the

stress states of the members according to the combination of end forces which are expressed in terms of six components of forces. As a matter of convenience, the AISC Specification is organized in such a way that the combinations of stress states match the real structural problems; for instance, the combined stress state subjected both to flexural and compression force corresponds to the beam column problems.

In a restricted sense, every structural design can be concluded to be a kind of iterative process toward a convergence which will satisfy the performance of the structure, which has two minimum requirements; safety and serviceability.

Since the safety and serviceability of the structures are a kind of compromise or agreement of users, considering the purpose of construction, they depend heavily on the type of structures and type of situations in which they are used. There are a variety of factors which influence the design criteria. One of these is property of material, which is closely related to the development of metallurgy. As a result, the design criteria of performance must inevitably be revised and updated, following the progress of current technology.

1.3 Analysis and Organization of the Specifications

1.3.1 Organization of the AISC and ACI

Fenves and Wright have shown the classification of the AISC criteria in Table 1-4, in which each of the criteria can be uniquely identified by the applicable entries from the three basic arguments. They have constructed the argument trees in such a way that the argument tree of physical component descriptions must be complemented by the other independent argument trees of performance attribute and limit state descriptions. Physical component

can be involved in "Facility", whereas the last two can be involved in "Performance".

In contrast, the organization of the American Concrete Institute Specification (ACI) is shown in terms of the four major arguments in comparison to the AISC in Table 1-4. Note that the ACI builds almost the same argument trees as the AISC, although the ACI seems to have more sub-arguments as described in the ACI, but the organization trees demonstrated in Table 1-4 reduce trivial items to a compact form.

1.3.2 Analysis and Organization of the Lateral Force Code

1.3.2.1 Analysis

Based on the previous discussion, the Lateral Force Code (LFC) is analyzed to reorganize it to a consistent form. Table 1-8 maps the result of analysis which indicates the relationship between the provisions and the corresponding arguments. The analysis yields the following facts:

1) Each provision always contains at least one of the sub-arguments in Facility and at least one of the sub-arguments either in Environment, Modeling or Performance. This relationship is like that of the subject and object in a "complete" sentence.

2) Section 4 never contains Environment arguments, which indicates that environmental description has already been specified in Section 1. Section 4 describes stress state and serviceability of the steel structures.

3) Since this code is obviously for specification of external loads, most but not all of its provisions are related to the Environment arguments.

4) The provisions of the LFC do not specify the design criteria of stress states which are concerned with the AISC and ACI. In Section 4(E), local buckling criteria are described, which supposedly belong to the argument

of the failure mode. Throughout the code this may be the only case in which a failure mode is mentioned. In nature, the failure modes are dealt with in the AISC and ACI instead.

5) Modeling arguments specify a kind of procedure of analysis. Therefore, if the Modeling arguments appear repeatedly in the provisions, then there is a tendency to be on the side of procedural specification. In this code, this is not markedly the case. However, Modeling arguments are supposed to be especially important in this code. The alternate methods of dynamic analysis and ductility of the system are precisely described with respect to a variety of members. These descriptions make the expression of the codes more complicated.

6) Section 4(c) and 4(F) contain the ASTM and AWS Specifications, respectively, as performance attributes which specify the strength of the materials and connections. The additional reference to the other independent specifications implies the existence of the hierarchy of the specifications themselves. We should know the upper level hierarchy which tells us the relationship among the other specifications.

1.3.2.2 Revised Organization

According to the analysis rule in organization level (Table 1-6), the sub-arguments at the same level of the trees should be mutually exclusive in order to avoid contradiction or redundancy. In other words, a given element should match only one of the sub-arguments at the same level. However, as shown in Table 1-8, most of the provisions contain more than two arguments at the same level. In order to avoid this violation, we should divide a provision into several parts for completeness and uniqueness, or reorganize the hierarchy of argument trees so as to be mutually exclusive at the same level, according

to the requirements of the individual situation.

Table 1-9 shows the revised and simplified organization of the argument trees based on the latter method. There may be as many as six basic arguments: Components, Connections, Property, Environment, Modeling, and Performance. The first three arguments belong to the "Facility" category.

1.3.3 Levels of Specifications

In the early work, most of the study has been concerned with the organization within a specification without mentioning the relationships among the other specifications which may be necessary for building structures. Most structures are under the constraints of several specifications at the same time. Regulatory agencies, as well as designers, should know the relationships among them. Better organization of the specifications leads to better understanding of provisions and ease of design programming where the common parts and different parts among specifications have been clarified because the design procedure of a structure involves making one more set of specifications in an overlapping manner.

In a design sense, the organization of a specification should be analyzed from the following perspectives:

- 1) level of the specification among the other specifications in the design configuration
- 2) common parts (similarity) and different parts among the specifications
- 3) permanent parts and temporary parts in a specification

The above acknowledgments yield not only ease of updating specifications, but also ease of updating design procedures which are obliged to follow after the updating of the current specifications.

Table 1-4 shows the comparison of the arguments of the AISC and ACI which deal with steel and concrete respectively, and may be considered to be at the same level and therefore to be similar procedural specifications in the design configuration. The comparison has revealed the similarity in each basic argument even though sub-arguments differ slightly.

Fig. 1-4 shows the level of the specification in which the BOCA Code,¹²⁾ the Lateral Force Code and the AISC Code are contrasted with each other. The BOCA Code, whose arguments are listed in Table 1-10, belongs to the "Facility" pattern, whereas the last two belong to "Interaction" and "Performance" patterns respectively rather than to the "Facility" pattern. It should be noted that "Facility" is always concerned with any specification as if it were a subject in a complete sentence. Conversely, we can conclude that if each provision is not concerned with "Facility" arguments, it fails through in completeness.

Fig. 1-5 shows a more generalized scheme of the level of the specifications, in which their roles of constraints are clarified with respect to the flow of the design procedures.

1.4 Generation Method of Specifications Text

It is proposed to extend the concepts and techniques developed previously and to apply the existing and new techniques to the formulation and textual expression of a new specification.

1.4.1 Organization of Outline

At the beginning of a project to build a new specification, the outline of the whole scheme should be proposed in order to grasp what items should be covered. The procedures are as follows:

1. Arrangement of fundamental arguments

Facility	n_1	(Number of sub-arguments)
Environment	n_2	
Interaction	n_3	
Performance	n_4	

2. Elimination of unnecessary arguments

Number of original combinations	$(n_1 \times n_2 \times n_3 \times n_4)$
Number of revised combinations	$(n'_1 \times n'_2 \times n'_3 \times n'_4)$

3. Reordering of outline

Index organization

Through the above work on a draft specification, it is usually discovered that some information is unnecessary and some is lacking, and index organization must be modified until the results converge to a satisfactory degree.

1.4.2 Description of Provisions

On the basis of the index organization completed in the previous step, a provision or paragraph is formulated and written. A provision should include all arguments or sub-arguments provided by the corresponding index. Fundamentally, the sentences of a provision should contain the following items:

- | | | |
|------------------------------|-----|-----------|
| 1. What (Facility) | } → | Criterion |
| 2. Where, When (Environment) | | |
| 3. How, Why (Interaction) | | |

Consequently, a provision leads to a criterion. The general form of a provision is expressed as follows:

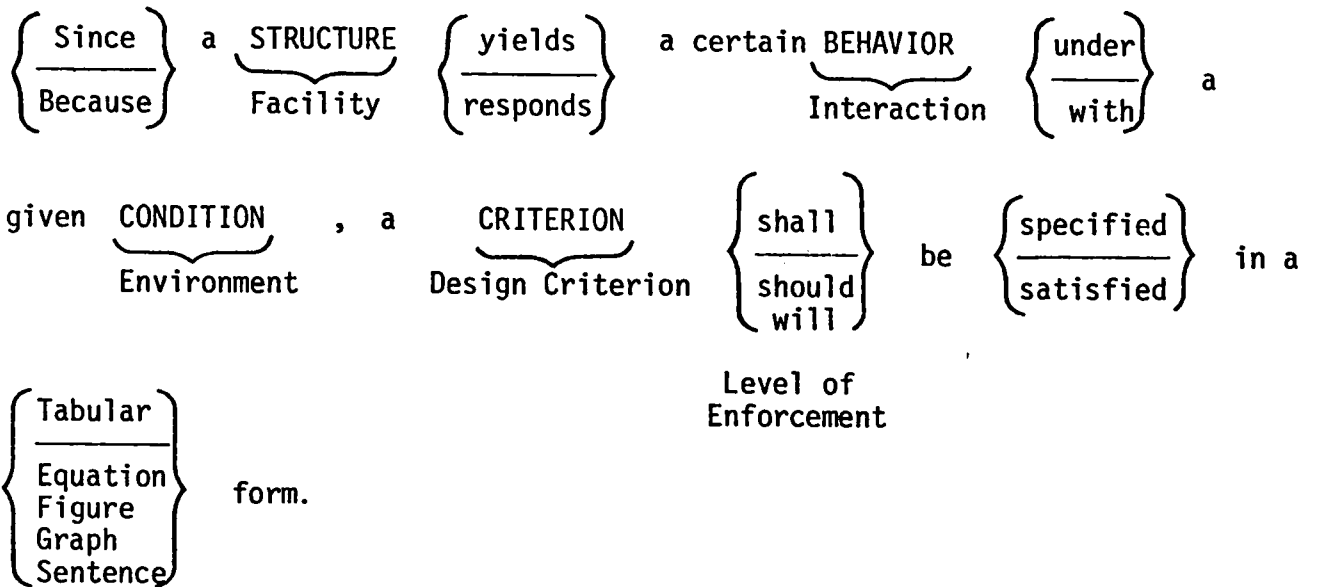

The following sentences demonstrate an example of a provision of the Life Safety Code (NFPA 101, Section 10~23) for revision according to the above rule.

[Original Provision (10-2242)]

Locks installed on institutional sleeping room doors shall be so arranged that they can be locked only from the corridor side. All such locks shall be arranged to permit exit from the room by a simple operation without the use of a key.

[Revised Provision]

In order for people in institutional sleeping room to
Human Being & Facility
 $\underbrace{\text{be safe}}_{\text{Interaction}}$ $\underbrace{\text{against fire (internal hazard)}}_{\text{Environment}}$, locks installed on exit^{*)}
Criterion

doors shall be so arranged that they can be locked only from the corridor side and can be opened by a simple operation without the use of a key.

*) It is necessary to define the type of doors clearly, to distinguish exit doors from window or closet doors.

Once a provision is written, it may turn out that certain combinations of circumstances have been omitted or give contradictory results, and the

paragraph must be rewritten. Decision tables are an excellent tool for representing the information content of individual paragraphs, and for checking them for consistency, completeness and lack of redundancy.

1.4.3 Network Expression

At the next level, related provisions must be grouped together with due regard to clarity, consistency and ease of cross-referencing. Again it usually requires several iterations before a satisfactory organization is reached. A network representation of the precedence relationships among the variables and provisions may be used to organize the sequence of the provisions in the textual expressions. The basic analysis techniques of the networks can be based on the contents described in Table 1-6.

1.5 Summary and Conclusion

1) The format of the text of the Specification must be viewed at three levels: (a) top level, (b) intermediate level, and (c) detailed level. The top level provides the overall organization of the text by hierarchically structuring independent bases for grouping the design criteria. The intermediate level provides for organization of the functional network used in evaluation of a particular criterion or set of criteria. Detailed level organization of provisions can be obtained by organizing individual decision tables.

2) The design configuration consists of four major components: (a) facility, (b) environment, (c) interaction, and (d) performance. Performance is considered to be the outcome of interaction between a facility and an environment. Consequently, these four basic arguments build the outline trees.

3) As a result of the analysis of a few specifications, such as the AISC, ACI, and the Lateral Force Code, it is proved that the above classification of arguments can cover their outline trees in the same form. However, as clarified in the analysis of the Lateral Force Code, most of the provisions contain more than two arguments at the same level, which violates the fundamental rule that the sub-arguments at the same level of the trees should be mutually exclusive. In order to match this rule, the provision should be divided into several parts for completeness and uniqueness, or the hierarchy of argument trees should be reorganized to be mutually exclusive at the same level.

4) Most structures are under the constraints of several specifications at the same time. In order to avoid overlaps and gaps among the specifications, the level of the specification should be clarified according to the procedural sequence in the design configuration.

5) For generation of new specification text, it is desirable to organize the index outline according to the planned arguments. In a strict sense, a provision should include every argument or sub-argument provided by the corresponding index.

6) These concepts and techniques may possibly lead to automatic generation of specification text and to constraints processing in the design procedure.

II. CONSTRAINTS PROCESSING

2.1 Background

2.1.1 Outline

A constraint is a particular application of design criteria intended to assure satisfactory function or response of the system under design. Constraints processing is the operation of evaluating constraints at various stages of the design process. In spite of the great necessity of constraints processing, general-purpose computer aids for constraint evaluation have not been available so far, simply because of the diversity of the constraints information. The diversity of logic employed in the formulation of any one standard specification has made it difficult and expensive to develop computer-aided constraint processors for that specification. In this section constraints processing is discussed through a trial computation and a model is proposed, especially for conformance checking of proposed designs against a given specification, rather than for computer-aided design.

Well established specifications which are analyzed and organized by the techniques mentioned previously are readily applicable to constraints processing since the processing is based on the same concept.

2.1.2 Design Procedures

Fig. 2-1 demonstrates information flow in structural design. The structural parameters are the fundamental structural data which are specified by the designer rather than derived by formulas or algorithms. The structural processing uses formulas or algorithms to derive structural attributes, in this case the processing is constrained by the facility code. The fundamental environmental parameters and the structural attributes are used in environmental

processing to derive the environmental attributes, where the processing is constrained by the environment code. The environmental parameters are also given as input data by the designer.

The environmental attributes and structural attributes are used in structural analysis to compute structural responses; in this case the processing is constrained by the interaction code.

Finally, structural attributes and structural response are used in constraints processing to evaluate the status of the design, and like constraints, the performance and safety code are associated with the processing.

The constraint values are attributes similar in nature to the structural attributes, environmental attributes, and structural responses; all are derived from more basic attributes in a chain of computation. As a result of the constraints processing, the structural parameters may be revised and the execution may be repeated until the constraint values converge.

2.1.3 Terminology

2.1.3.1 Constraint and Design Criteria

A design criterion is a functional relationship intended to provide an adequate margin of safety with respect to a particular mode of failure. A constraint is a particular application of the design criteria. A constraint may be named by the mode of failure of the design criteria.

2.1.3.2 Attributes and Parameters

As shown in Fig. 2-1, structural attributes, structural responses, and constraint values are somewhat artificial, since all these can be considered to be system attributes. Parameters are a special class of attributes which have empty lists of ingredients in the network.

2.1.3.3 Ingredients and Dependents

Dependents are data whose values are affected by the values of the data at the lower level. Ingredients are data used to evaluate the data at the higher level. Data explicitly required of the node in question are defined by an INGREDIENCE list which contains ingredient attributes. The DEPENDENCE list for an attribute defines the attributes which are expressed explicitly in terms of dependents.

2.1.3.4 Sets and Subsets

A subset is a minimum unit of a network which expresses a design criterion or formulates the design procedures. A set is a combined module of subsets and is considered to be a constraint as a particular application of design criteria.

2.1.4 Execution of Network

2.1.4.1 SEEK and WARN Modes

There are two basic operations which recur often in constraints processing and the evaluations of attributes: These are to SEEK the value of an attribute and to WARN that the value of an attribute is likely to have changed. The condition of an attribute is of concern in those operations. This is recorded by a STATUS variable which is a flag for each attribute which indicates whether the value of the attribute is valid or void. The value for an attribute is required; if its status is void it must be computed from its ingredient attributes or parameters. SEEK is repeated for the ingredient attributes until their status is valid. WARN is an operation that proceeds from the parameter at the lowest level to the attribute at the higher level in the network. If a parameter is changed, then the values of attributes which depend on it are void. It would be

possible to reevaluate the affected attributes instead of simply resetting their status. However, if a number of parameters were altered, immediate reevaluation would be wasteful. The pair of execution modes, SEEK and WARN, are very useful for conditional execution of the network.

2.1.4.2 Stack Technique

A stack is a mechanism for storing information and retrieving it using the Last-In-First-Out (LIFO) principle, as opposed to a queue which uses First-In-First-Out principle. The stacks are particularly convenient for situations when a process has to be interrupted and information on the job status must be recorded in a stack entry so it can be retrieved and job resumed from the point of interruption after processing other similar processes in a recursive fashion. A model of a stack is shown in Fig. 2-2(a).¹⁾ Applications of stacks are numerous; some of these are for the operating system where CALL and RETURN of subroutines are frequently used, and for the network system where a node has many incoming and outgoing branches (Fig. 2-2(b),(c)).

The operating mechanism of stacks is simplified by using the two-dimensional array shown in Fig. 2-2(d) which is set up for storing suspended nodes at execution time. The length of the stack array depends on both the level of network and the number of ingredients suspended.

2.1.4.3 Recycling Operation

In the majority of cases, a designer may want to test a number of related constraints or alternatives before deciding on the final design. In most of the alternatives to be tested, a large number of parameters are likely to be common and only a few will have different values. In such cases, ideally, the algorithm should be expected to require only the

changed data as input and execute only those operations which are functions of the modified data. All data and operations which do not change from the previous cycle should not have to be repeated.

There is another case when recycling is needed. Suppose the case when we need to check the compression member criteria of a wide-flange section which is composed of two flanges and one web plate. The unstiffened elements of the flanges should satisfy the minimum requirement of the thickness ratio to width individually in upper and lower parts. Consequently, the algorithm of network related to the local buckling criteria of this plate should be repeated twice. In contrast, the compression stress ratio of the cross section is evaluated only once. Fig. 2-5 illustrates the whole scheme of compression member criteria due to the AISC. It is apparent that the operation number of recycling at each criterion in the network is different locally and consequently the arrayed sets of parameters for the recycling supply are different in number. The implementation of the network becomes much more complicated and sophisticated. The operation numbers of recycling at each criterion are unknown until the type of cross-section is decided at execution time.

2.1.5 Organization of Provisions

A provision is considered to be a unit of design criteria of the specification and constraints are combinations of design criteria used for a particular application. We need to organize provisions both from a specification viewpoint and a computer-aided viewpoint.

2.1.5.1 Provisions in Specifications

The provisions fall into two categories:

A) Fundamental provisions

B) Particular provisions

A) are specified for general use, whereas B) are specified for particular types of structures and thus lose their generality. For instance, the AISC has four basic sub-arguments as a type of component; members, elements of members, connectors, and connections. This classification yields fundamental provisions related to them and they are applicable to any type of structure. On the other hand, the particular provision concerned with stiffness of plate girders is not applicable to other structures.

In general, the constraints are mixtures of both the basic and additional provisions. Basic provisions are from a fundamental provision or a set of fundamental provisions, whereas additional provisions are special requirements for particular types of structures.

2.1.5.2 Provisions in Network

In a computer sense, a subset is considered to be a minimum unit of module which corresponds to a fundamental or particular provision expressed by means of a network. A set is a linked module of the subsets and organizes a constraint. Commonly speaking, a subset and a set are considered to be a subroutine and a main program of the constraint processing, respectively. At the lowest nodes of the network, parameters exist as data entries. There are two ways to provide input data to each parameter, namely, direct method and indirect method. Usually the data generated by design systems which are external to the constraints processing is different from the parameters required by the specification. For example, some of the provisions of the AISC are interested only in the area of the cross-section as a result of the calculation of the size of the components, although area is a function of the type of cross-section. Consequently, the information

externally generated should be converted to the specification data base. The procedure for conversion linkage is referred to as "data mapping" and it generates "mapped parameters". This feature is just like the I/O configuration in the computer system. The transient forms of the network are demonstrated in Fig. 2-3.

2.2 Application of Conformance Checking to a Truss Bridge

2.2.1 Task

This section demonstrates the concept developed in this study by applying the AISC to a truss bridge.

Fig. 2-4 shows a profile of the girder with 216' in length, in which the maximum or minimum member forces are assumed approximately on the basis of the AASHO Specification.²⁾ Suppose that conformance checking is requested for the applicability of W14 x 87 to the compression members as well as to the tension members.

2.2.2 Outline of the Specification

According to the AISC Specification, the outline which is concerned only with axial stress is stated as follows:

Axial Stress

Tension

Yielding

Excessive Slenderness

Compression

Overall Column Buckling

Plate Local Buckling

Excessive Slenderness

In the above case, the ordering of the outline is: stress state, failure mode, and component (type of cross-section). The last triplet is implicitly defined by the type of members.

2.2.3 Networks of Tension and Compression Member Criteria

Fig. 2-5 illustrates the networks of the tension and compression member criteria due to the AISC, in which the nodes circled with double solid lines indicate the subsets which are also defined by the individual networks and are the minimum unit of recycling. At each node, the number of recycling is indicated in Fig. 2-5 for the particular type of cross-section, that is, for a wide flange. The nodes which have capital Z as the initial letter, such as ZOA, represent a function which summarizes the results of a recycling operation. The subsets of network are shown in Fig. 2-6 through Fig. 2-12.

2.2.4 Attributes and Parameters Lists

Table 2-1 lists the attributes and parameters which are associated with the tension and compression member criteria. The data have the following attributes:

- T : Criteria
- S : Subset
- D : Decision table
- F : Function
- P : Parameter

Out of them, decision tables and functions are expressed by function type subroutine.

2.2.5 Decision Table Expression

Table 2-2 through Table 2-7 cover all of the decision tables listed in Table 2-1.

As a result of analysis of the decision table, we can find two types of derived decision networks as shown in Fig. 2-13; these are called complete and incomplete decision tables. In the case of Fig. 2-13(b), four else rules are derived. Strictly speaking, at the time of building to new specifications, the provision should be revised into a complete expression. However, at the stage of using the established specifications in the design system, special consideration should be given to the exits of the else rule without revising the incomplete provision itself.

2.2.6 Evaluation

2.2.6.1 Tension Member Check (Fig. 2-4)

[Case 1] Member (L_2L_4) ---- $P = 891$ kps, $L = 324$ inch, W14x87

[Case 2] Member (U_1L_2) ---- $P = 446$ kps, $L = 458$ inch, W14x87

Table 2-8 shows the parameters and the procedures of calculation. In case 1, the slenderness ratio is satisfactory, whereas the tension stress ratio is not. In the second trial, in case 2, L and P values are altered, keeping the other data unchanged. The slenderness ratio is evaluated again because the L is changed although the criterion is obviously satisfactory. In the network of BRTLE1, RT, FFT, and FT are "seeked" again, and the result is satisfactory. In conclusion, W14x87 is available only for member U_1L_2 .

2.2.6.2 Compression Member Check (Fig. 2-4)

[Case 1] Member (U_4L_4) ---- $PCOMP = -171$ kps, $L = 324$, W14x87

[Case 2] Member (L_2U_3) ---- $PCOMP = -291$ kps, $L = 458$, W14x87

The parameters for each subset are tabulated in Table 2-9 and Table 2-10. Note that a wide flange has four unstiffened elements and one stiffened element. Consequently, for each element local plate buckling

and the other conformance checking are required even though the shape of the cross-section is doubly symmetric so that the trial can be reduced to only one for the flange plate. However, in general, the fact of duplication cannot be anticipated until the parameters are compared with each other. As shown in Table 2-10, the actual area (ZACTST) and effective area (ZEFFST) are the summation of the five elements of the cross-section. In both cases, the slenderness ratio and the local buckling requirement are satisfactory, whereas the compression stress ratio is not in case 2. In conclusion, W14x87 is available for the compression member U_4L_4 .

2.3 A Model of Constraints Processing

2.3.1 Outline

Fig. 2-14 illustrates the general computer system approach.

Implementation of the system of programs which will perform both conformance checking and computer-aided design in a general way would be a formidable task. Only those parts of the system which are directly associated with the use of specifications for conformance checking are implemented as parts of the general capability. The system program is composed of three major processors:

- A) Network Linkage Editor
- B) Data Manager
- C) Executor

The executor executes constraints processing which is in the form of the "mapped set module" generated by the network linkage editor, with the help of the data manager which provides input data to network parameters according to the request from the executor.

2.3.2 Network Linkage Editor

2.3.2.1 Capability

This processor is directly associated not only with development of specifications in the form of output printing, but also with the use of specifications for conformance checking in the form of the linked network module in the file.

The processor is capable of generating the following information:

- A) Subset Network Library
- B) Outline Index Library
- C) Set Network Module (According to network organization data)
- D) Parameter Library (According to network data)

The output printing formats of A), B), and C) are substantially like Fig. 2-7 or Table 1-5 illustrated in the previous sections. They are useful for the development of specifications in the visualized forms of network and outline. The parameter library is completed into an executable form through data mapping by the data manager.

2.3.2.2 Internal Form of Network

Internal form of network does not differ in any way between subset and set. The conceptual distinction comes from the difference of organization process through the linkage editor. The subset networks are stored in a library for general use like the subroutine package. According to the linkage request by the network organization data, a set network is established, referencing to the outline index library if such an organization is requested.

The internal form of network is illustrated in Fig. 2-15. It is composed of four major tables:

- A) Attributes Table
- B) Ingredients Table
- C) Dependents Table
- D) Subscripted Data Table

Each node of the network has a columnwise information in the attributes table, in which some of the rows contain pointers to B), C), and D). A node of information is designed in such a way that it has capabilities of:

- 1) Stacks execution by the executor
- 2) Conditional execution of network
- 3) Recycling execution for repeated calculation within a subset network

Each node has a FLAG which indicates whether the data defined in the previous execution is valid or void. If the flag is valid, then the SEEK mode of the executor can resume without penetrating to the lowest level of the network. If the parameters are modified, then the WARN mode of the executor may make the flag associated with them void.

If the node is required to be subscripted by the network organization data, the linkage editor allocates the subscripted data table and sets up a pointer to it. However, its size is decided at execution time, depending upon the type of checking data.

2.3.2.3 Outline Index Library

The outline data is composed of two types of input; one is the provisions title and another is the arguments title, as shown in Table 1-8. Both types of information are stored as the outline index library. According to the ordering request, such as "Components", "Limit states", and "Stress states", as demonstrated in the AISC organization, the outline index is organized to an ordered tree structure (refer to Table 1-5). A certain nodal point in the

outline tree, which is followed by a group of network branches, can be a data entry to organize a "set network" when assigned by the "network organization data".

2.3.3 Data Manager

2.3.3.1 Capability

The major role of the data manager is to manage I/O jobs concerned with the parameters in the network. In nature, the data manager is identical to the one which is a part of the executor shown in Fig. 2-16. It has the following capabilities:

- 1) Data mapping
- 2) Data retrieval both from the design data file through the interface and the section table
- 3) Initialization of the working table and copy of "mapped parameters"

The data which defines a proposed structural design can originate in many forms. As usual, the relationship between the physical location of data, generated by the systems which are external to the conformance checking system, and the data required by the specification for conformance checking is not implied in the specification. Consequently, the externally generated data should be mapped onto the specification data base, that is, onto the form of parameters. The programmed interfaces permit the mapping system to access the corresponding data in the design data file. Those interfaces are additional input provided by the user and may be simple programs or complex data management systems, depending on the method used to generate the design file.

Although the information of the cross-section of the member is included in the design data, it is convenient to separate it from the design data and

reference it to the independent file of the section table ³⁾ which is arranged for general use.

2.3.3.2 Parameter Library

Parameters which have no ingredients build another independent library although they are still a part of the attributes in the network. The major difference between them is that the parameters work as data entry and are in contact with the external world on the frontier. The parameter library consists of a variety of tables which construct a data hierarchy as shown in Fig. 2-16.

- A) Parameters Table
- B) Subsets Table
- C) Cycling Table
- D) Mapped Parameters Table
- E) Element Pointer Table
- F) Parameter Elements Table
- G) Parameter Dependents Table

The first two are generated by the network linkage editor, whereas the rest are generated by the data manager, based on the mapping commands. Note that the first two are the specification data base and the others are the externally generated data base. In a global sense, the parameter information contains three basic items: (1) parameters list, (2) cycling information, and (3) design data (parameter elements). For simplification, the last two can be neglected in the system and the constraints processing can still be operated without such a complicated scheme. In other words, if the parameters are provided directly by hand, the system works without the aid of the data manager.

As mentioned previously, since the operation number of cycling depends both on the individual subset and the type of the cross-section of the member, B) and C) should be organized so as to possess such information.

At the lowest level, parameter elements which correspond to design data exist in a table format where the data are derived both from the section table and the externally generated data. Each parameter element has parameter dependents list in order that when a design datum is modified, the change can be propagated to the attributes through the parameters related in the network.

2.3.4 Executor

2.3.4.1 Capability

The computer-processable form of the specification, generated in the preceding steps into "set network" and "mapped parameters" is made available to the conformance checking by the executor. As illustrated in Fig. 2-14, the executor itself is divided into three parts:

- A) Input interpreter
- B) Data Manager
- C) Stacks

The model is one of two general approaches to the operation of the conformance checking system and corresponds to the typical batch type operation, where the user, through the mapping system, directs that all data concerning a particular design be extracted from the external data bases and moved into the specification data base prior to entering the first request for conformance checking.

2.3.4.2 Input Interpreter

This processor accepts checking requests and controls the processing of execution. The contents of the checking requests are summarized in

Table 2-11, some of them are provided at the time of "data mapping" even though this may be delayed until the execution time. This capability implies that if the data is missing or mapping is not complete in part, the mapping system can then request mapping that commands or the corresponding data be supplied. Once the arrangements are implemented completely, the control is transferred to the "stack" processor.

2.3.4.3 Function Program

In this system, a node of the network corresponds to a "Function" which is expressed by means of a decision table or formula and generates a certain value based on its ingredients. Regardless of its expression form, a node is expressed by a function type subroutine, although a conversion program is necessary for decision tables. The functions can be compiled by the FORTRAN compiler and as a whole they are set up into an executable module by the system program.

2.3.4.4 Execution

The execution of the network is operated either by SEEK mode or the WARN mode as described previously. A conformance checking request indicates an entry point of the corresponding network of the constraint. The ingredients of the current node may be copied in the stack table and the information of ingredients are "seeked". At the first cycle, the seeking may penetrate to the lowest level parameters, then the control is switched from the "Stacks" to the "Data manager" which can retrieve the parameter elements either from the "cross-section table" or the "design data file". Once all ingredients associated with one node are arranged, the control jumps to the "Function program" to calculate a functional value using the ingredients as the arguments. As a result of the calculation, the answer

is memorized in the "Parameters table" or the "Attributes table", thus making the FLAG valid. Then the control returns to the Stacks.

When a parameter has been modified in the case of local change of the original design or in the case of recycling operation, the WARN mode makes the flag of attributes void, tracing back to the dependence lists. At the second time of recycling, the SEEK mode will follow only the nodes which are void.

2.4 Summary and Conclusion

1) Constraints processing is the operation of evaluating constraints at various stages of the design process. Herein, the constraints processing has been discussed through a trial computation and a mode of the constraints processing is proposed, especially for conformance checking of proposed design against a given specification.

2) The concepts of (a) decision table of provisions, (b) specification networks, and (c) organization of outline become powerful tools not only for formulation and expression of the specifications, but also for constraints processing.

3) In particular, the three level forms appear to have considerable value for different uses: (a) a textual or an abstract form for organization checking, (b) a computer-processable form for generating computer programs.

4) The information of the outline organizes a tree structure which is identical to the network expression. Consequently, a node at a certain point in the outline tree, which is followed by a branch network of the design criteria, can be used as an entry point of the constraints processing, according to the level of the conformance checking request. In turn, the outline information is stored in the index library and used for the

organization of the constraints as a linked form of the new network.

5) Since the elements of the member require local conformance checking one by one, local recycling operation in the constraints network is necessary, independently of the global recycling operation. For example, in the case of wide flange sections, five recycling operations are required for the local plate buckling check, whereas only one is needed for the stress ratio check as a global operation.

This scheme makes the constraints processing more complicated.

6) The stacks technique is very useful for the operation of the specification networks. The SEEK and WARN modes are powerful under the conditional execution for recycling jobs of the network.

7) In general, the data generated by design systems which are external to the constraints processing are different from the parameters required by the specification. Consequently, the information externally generated should be converted to the specification data base through the "data mapping" process. In order to provide design data to the parameters in the network, a powerful data management system is required.

8) The constraints processing program is composed of three major processors: (1) Network Linkage Editor, which organizes the specification networks in a computer-processable form, (2) Data Manager, and (3) Executor which accepts checking requests and controls Stacks jobs of the networks.

9) Based upon the scheme described above, flexible and general purpose constraints processing can be expected to be available, following the current specifications which may be updated according to the development of the relevant technology.

III. NUMERICAL CONTROL SYSTEM IN FABRICATION

3.1 General Views

3.1.1 Background

The past 30 years after World War II have been a time of remarkable accomplishment in steel structure building. During this period there has been unprecedented growth and achievement in engineering, materials, fabrication, construction, and aesthetics.

The two most revolutionary developments in shop fabrication are the use of numerically controlled (N/C) equipment and welding. While the full effects of N/C operation are just beginning to be realized, welding has already had an enormous impact on field construction.

The N/C equipment can trace its beginning to the 18th century, when a French engineer developed a loom controlled by an endless chain of perforated wooden cards. However, it was not until the early 1950's that the first true automatically controlled machine tool, a milling machine, was developed.¹⁾ This machine had facilities for remembering a set of instructions, which controlled the speed and feed rate of the milling cutters. Since then, industry has seen the quantity and application of N/C machines expand at an impressive rate.

Programming of an N/C operation is executed either manually or with the assistance of a computer. At the first stage, most programming is done manually, especially in N/C drilling. The programmer writes out the machine instructions in tabulated blocks of information on a program manuscript (Part Programming, Fig. 3-1(a)). These instructions are then punched into the control tape by means of a suitable tape punch. The machine reads a

block of information at a time and executes the instructions in the block, after which the next block is read. If the operation is the drilling of holes, the location of each hole to be drilled is given in a separate block of information. The machine reads the location of the next block, positions the work piece for the drill, drills, then reads the next block, and so on (Fig. 3-13).

Fig. 3-1(b) is the flow chart for a computer-executed N/C program. The part programming in this case is quite different from manual programming. Instead, it consists of computer language statements suited to numerical control. Each statement is punched into a computer card, and the card deck is processed by the computer to give a geometrical solution for the part geometry. This produces a general solution, suitable for any numerical control machine. The computer solution, through a postprocessor, could be applied to an N/C drafting machine to draw the part, or to an N/C drilling machine or an N/C gas cutting machine directly. Since every N/C machine must have its blocks of information arranged in a special format as shown in Fig. 3-13, the general solution should be "postprocessed" (reprocessed). From the second computer run a suitable tape is prepared for insertion into the tape reader of the machine.

A numerically controlled machine consists of two parts: the processing machine and the machine control unit. The machine control unit contains the tape reader and electronic circuitry that controls the positioning motors operating the axis motions. Two types of control systems are used to operate N/C machines, numerical positioning control (NPC) and numerical contouring control (NCC).

A third type has recently been introduced, direct numerical control (DNC).

The simplest type of control is positioning control. Its function is to move the machine table or machine spindle to the required position at which the operation is to be performed - drilling, boring, etc. The positioning and the processing are done in sequence in positioning control regardless of its path. Such a system is suited to a drilling machine, for example. In positioning control, since no operation is performed during positioning, the path taken to arrive at the command position need not be restricted or controlled (except perhaps to avoid a collision between fixturing and spindle).

A continuous path or contouring system has independent control of the speed of the X and Y drive. Thus, profiling can be performed at any and all angles to the two axes. Drafting machines and flame-cutting machines require a contouring control system.

Most positioning machines use absolute dimensioning from an origin. Contouring machines use incremental positioning from the last position.

The third type of numerical control system is direct numerical control. The economics of this system are somewhat involved, and the method is suited only to very complex N/C systems, such as multiaxis machines or systems of operating several N/C machines. Instead of a tape reader and machine control unit, a (small) computer performs the machine calculations and generates the electrical impulses to move the motors that position the work table or spindle. The basic problem in this control method is one of incompatibility in information processing. However, the major advantage is that the computer can program many N/C machine simultaneously.²⁾

Evolution of N/C programming systems originally started early in 1956 when an automatic programming system was suggested and demonstrated in

MIT Engineering Report #16 by Arnold Siegel. Since then an advanced symbolic programming concept was being developed at MIT under Air Force sponsorship. It was named APT - Automatically Programmed Tools.³⁾ The basic theory was to develop a program by which the part programmer could communicate with the computer using a simple English-like language.

Expanded development was done in the aerospace industry in the U.S.A. in the 1960's. The Numerical Panel (NP) organized by the Aerospace Manufacturing Committee (AMEC) established the APT Task Group under the direction and coordination of MIT. The effort was culminated with an official release of the APT Systems in December 1961. The APT Long Range Program (ALRP), sponsored mainly by aerospace companies, followed in 1965 under the leadership of the APT project staff of Illinois Institute of Technology Research Institute (IITRI). Through it the ALRP has grown tremendously and in 1969 had over 200 fee-paying participants in the world, including many European companies, as well as several in Japan.

In contrast, in the naval architectural industry, N/C systems originated in the European countries first, based on manual coding to N/C hardware. Inefficiency of manual coding and the particularity of patterns in ships, which cannot be covered even by APT, yielded new types of development in N/C language systems. In the last half of the 1960's, Japanese shipbuilding companies developed their own systems independently.⁴⁾

Table 3-1 tabulates the major N/C systems in Japan as well as in Europe.

3.1.2 Outline

In the design field, the computer has completely revolutionized conventional designing techniques. This trend is also occurring in the production field and changing production methods. Rapid improvement in

the capacity of computers has allowed numerical control techniques to be put into practice even in the production field. With a view to the automation of shop drawings, especially of template shop operations, the Steel Structures and Machinery Division of Nippon Kokan, Ltd. (NKK) has carried forward an N/C system development scheme conceived early in 1969. The first phase of the project was completed early in 1970, almost a year after the initiation of the scheme. The major purpose of the first phase of the project was to develop a BRIdge and STeel Structure Lofting LANguage (BRISTLAN), with a view to applying it universally to general lofting. BRISTLAN as developed was actually applied to the automation of template shop operations for bridge fabrication.

At the same period, in the middle of 1969, a complete replacement of floor drawing template shop operations by the new N/C production system was decided in the case of the project construction of the new fabrication factory in the Tsu Works of NKK. For this purpose, a stress was laid on the development of subsystems for supporting BRISTLAN. The ROAD (Road) program and BRMESH (BRIdge MESH) programs have been developed for coordinate calculation of bridge structures. A few postprocessors were prepared for the near N/C machine tools. The new Tsu Works, employing a complete N/C system, was put into operation in October 1970, and is still in operation although it was updated in 1972.⁵⁾

At the beginning of the operation, the total amount of monthly production of bridges in the yard was about 1000 ton. One year later it had reached almost 1500 ton. A rapid increase of production jobs obliged us to revise the whole N/C system basically again. In order to reduce the responsibility of the BRISTLAN processor - it seemed that every capability was concentrated

in it - greater stress was laid on the development of subsystems by distributing its capability into them. The major revision in the system version up to 1972 was in two points. One was to complete coordinate system programs which calculate the road profile as well as bridge structural location. Through the automatic input of design details from the ROAD program, the BRMESH program had the capability of calculating member sizes of webs, flanges, and so on, which is remarkably useful in template shop operations. Another change was to make a coordinate conversion program which convert 3-dimensional coordinate data to plane surface data, since this capability was already in the BRISTLAN processor.

The automatic generation of plane surface data in file released the part-programmers from worrying about the treatment of 3-dimensional coordinate data in their jobs. Several subsystems have been working well independently and interrelatedly in each job step. As a whole, the system itself has been approaching the condition of an integrated system.

The second phase of the project was to apply the BRISTLAN system to building frame fabrication in 1971, one year after its success in the bridge field.⁶⁾ Unfortunately, the difference in fabrication methods prevents making use of the same techniques as in bridge construction. It was decided that the N/C system should cover a much wider range of fabrication jobs: fabrication drawings, shop drawings, template shop operations, and even material treatment. In particular, fabrication drawings as well as design drawings are very important, since these cover more than half of the jobs of shop drawings and template shop operations. The large number of member pieces of building structures forced us to make the system more complicated and sophisticated than that used in bridge construction. In a computer sense,

the nucleus is in the data management system rather than in the N/C system, although highly developed N/C techniques are required for a variety of drawings. For this purpose, BRISTLAN2, MRG (Material Report Generator), and SDPC (Secondary Data Production Command) have been developed as subsystems. In the early spring of 1972, about one year after the initiation of the scheme, the second project was completed with partial success. For various reasons, primarily of an economic nature, only the MRG subsystem has been used in the Shimizu Works of NKK since then. Their data management system, as well as the N/C system, will be discussed later in this paper.

The third phase project begun in 1973 was to develop a total system including both the design system and the N/C system. Computer graphic technology has made possible Computer Aided Design (CAD). This concept depends entirely on the capability of hardware supported by a sophisticated data management system. The emphasis has been put on the automatic modification of algorithms and corresponding data which deal with a variety of drawings in design and fabrication. A sudden change in design should be immediately propagated to every correlated section in the yard.⁷⁾ The change of design implies addition or deletion of algorithms of instructions as well as a change of the data file in the N/C drawings.

In 1974 the project was completed with partial success in the design field and has been in operation since then.⁸⁾ The third project will not be discussed in this paper. Instead, a data management system in the total system will be proposed using the network concept described in the previous sections.

3.2 N/C System in Bridge Fabrication

3.2.1 Conventional Flow of Work

In general, superstructures of steel bridges are fabricated in yards based on contracts with public agencies. Fabricators must deal with many kinds of structures containing a variety of shapes of members. Fig. 3-2 shows a general flow of production in bridge construction, including both the process of design and fabrication. Automation of production is possible in two major ways:

- 1) In design and fabrication work
 - a) Computer Aided Design
Numerical Control Drawings } Development of software
 - b) Flame Cutting and Drilling -- Development of hardware
- 2) In management and scheduling
 - c) Scheduling of best use of yard space
Scheduling of assembling in yards
 - d) Management of quality and quantity
Management of material stocks } Development of software

In this paper, discussion is concentrated only on a) and b). These areas directly associated with the built-in procedures in the production flow, whereas the rest are indirectly associated with the former. In the first phase project, the major emphasis was put on N/C template shop operations and N/C flame cutting and drilling operations.

3.2.2 Environments in System Design

For the new N/C system, which covers shop drawings in fabrication, the following items have been emphasized strongly:

1) Universality for general lofting work in fabrication.

In general, the steel workshops should be able to fabricate not only bridges but also a variety of other steel structures such as buildings, heavy plants and pipe structures. Once a perfect N/C system is projected instead of the conventional method of full-scale drawings on shop floors, the system should have universality in general lofting work on all types of structures. From the viewpoint of figure processing, putting aside the particularity of each structure, the lofting work is broken down as follows:

- a) Development of 3-dimensional structures into 2-dimensional plane elements
- b) Spreading of space surfaces
- c) Development of tubes and pipes mutually intersected

The figure processing of structures can be broken down into two steps. One is preprocessing, which generates structural coordinates and expresses the shape and profile of the structure in 3-dimensional form. Another is figure processing, which generates the 2-dimensional shapes of the components based on the preprocessed data.

2) Consideration of fabrication techniques in shop works.

In shop work, various kinds of problems should be taken into consideration, such as change of shapes of members caused by rotation due to the camber effect of the bridge, shrinkage due to welding and cutting, and so on. In general, these problems arise from the fabrication methods required in each particular shop. This may be one of the major reasons why general purpose processing programs such as APT have not been so much applied in different fields as might have been expected.

3) Integrated system from design to fabrication.

The profile of road lane should be first calculated in the design process, which allocates the positions of major structural members in the bridge. This work originates the primary design and design details. The location data of the structures produced in design must also be available to the N/C system used in fabrication so that they should be filed in the storage in a retrieval form appropriate for the next steps. For this purpose, data management techniques are necessary.

4) Smooth connection between hardware and software.

Original figure data produced in the N/C processors should be edited in general format so as to be acceptable to future N/C machine tools. Basic expression of figure is so important that every figure processor aims at those final forms and from them every postprocessor originates readable codes proper to its N/C machine tool. For this purpose, the basic and special list formats, "SEGMENT LIST", have been studied and incorporated. Smooth connection with new N/C machine tools can be expected only by making their postprocessors compatible with these forms.

The original figure data has the following four categories so that N/C information for each tool can be produced respectively.

- | | | |
|-------------------------------|---|-----------------|
| a) Outside edge line | } | N/C gas cutting |
| b) Inside edge line | | |
| c) Location of drilling holes | | -- N/C drilling |
| d) Marking line | } | N/C drafting |
| e) Characters | | |

The categories described above should be visualized by drafters for correctness checking.

3.2.3 Outline of BRISTLAN System

Fig. 3-3 shows BRISTLAN system flow.

1) Problem Oriented Language, BRISTLAN.

Major emphasis has been put on development of the BRISTLAN processor, which takes the form of a problem oriented language in the sense that the processor has been built up for special purposes, taking its orientation from particular problems. It interprets a sequence of commands part programmed and generates original figure data. It is completely different from a procedure oriented language such as FORTRAN. In order to support the BRISTLAN processor, a few subprograms, ROAD and BRMESH, have been developed.

2) Primary Data and Secondary Data.

In design, profiles of road lanes are calculated at each station based on schematic information of road planning. The positions of bridge structures are allocated accordingly. Location data of structures generated by ROAD program are used both in design and fabrication work.

These data are called "Primary Data (PD)" and are filed in retrieval form for the next step. They contain functional parameters which express the profile of road lanes at each station such as at piers, at supports of girders and at positions of sway bracings. Based on the surface information of the lanes in PD, 3-dimensional coordinates of structural members are required in detail. Adding structural details to PD, such as main girder heights, position of stiffeners in webs and location of lateral bracings, structural locations are calculated by the BRMESH

program and filed as "Secondary Data (SD)" in retrieval form for the BRISTLAN processor.

3) Figure Patterns and the Macro Library.

Input to the BRISTLAN processor is written in BRISTLAN language by the part programmer. The BRISTLAN processor has access to both the "Secondary Data" file and the "Macro Library" which stores a variety of figure patterns for common use. Since a figure is a set of a variety of patterns, it is very useful to set up common parts in the library. This implies accumulation of experience at part programming, which leads to reduction of part programming in subsequent jobs. The subprogram concept in the system requires the existence of an object program and a linkage editor which connects them to the main part program. In turn, these requirements yield a data management system attached to the processor and a sophisticated high level language system.

4) N/C Information and Fabrication Methods in shops.

After visualizing correctness of production by drafters, the original figure data is converted to information for a variety of N/C machine tools by postprocessors. N/C information is used for fabrication work in many ways:

- a) 1/10 scale template films drawn by drafters.
- b) Assembling them and then nesting them into rectangular plates (with order size or regular size) by hand.
- c) Photo enlargement from 1/10 to full scale and printing onto steel plates by means of an Electronic Marking Machine (EPM). (Automation of marking of figures in shop work)
- d) Manual gas cutting along piece-marked lines printed by EPM.

- e) Direct cutting of plates by N/C flame cutter.
- f) N/C drilling.
- g) 1/10 and 1/25 scale drafting for visualized inspection.

3.2.4 Subprogram and Macro Library

Even in a routine job, there are a great number of part programming jobs and input data associated with them. It is a reasonable thinking process for us to accumulate past experiences and utilize them for succeeding jobs. This principle is also valid in the figure processing system as a form of standard pattern library. Accumulation of common patterns may lead to great efficiency in part programming and gradually reduce the cost of production as a whole. There are two ways to store standard patterns in the library: one is to hold them in the form of a main program and the other in the form of a subprogram.

The pressure of necessity yields the following requirements in language design:

- a) The necessity of a LINKAGE EDITOR which links subprograms to the main program.
- b) Generation of an "Object Program"*in compact form, derived from the "Source Program".

(* Note that it differs from the machine codes as used by the Assembler. The BRISTLAN Object Program is packed into 16 bytes in length from a source card with a length of 80 bytes.)

The Macro library is a kind of built-in subprogram registered in the common library. This built-in Macro library is of great importance for the reduction of daily part programming jobs. It is also of great concern which portions of shapes and which shapes of structures should be registered as standard patterns. In conclusion, the Macro library falls in two categories:

- a) Standard patterns common to almost every type of job.
- b) Standard patterns frequently appearing in a particular job.

The latter should be arranged in a temporary library for limited use.

On the other hand, the former is registered as if it were built in functions in the permanent library in the form of the following categories:

- a) Nonclosed shape patterns for outside edge lines (18 types).
 - (ex) Slots, scallops, and other cutting patterns for N/C gas cutters.
- b) Closed shape patterns (22 types)
 - (ex) Manhole, drain hole, ellipse, gusset, polygon.
- c) Patterns for drilling holes (16 types)
 - (ex) 2-dimensional array in wide-flange

Fig. 3-5 shows some of these patterns.

3.2.5 Secondary Data (SD)

Fig. 3-6 shows the internal form of Secondary Data in the file.

Secondary Data is composed of three levels of data: Directory, Header and Data part. The first two are pointer tables which contain the addresses of data desired. The Directory stores job names and corresponding initial addresses to the Header which also stores labels of Secondary Data and their relative displacements from the origin. Usually, SD is expressed in 3-dimensional array form, such as A(I,J,K). The physical meaning of the label and the subscripts is demonstrated in Fig. 3-6 and Fig. 3-20. I, J, K indicate station numbers in x, y, z directions respectively.

(ex) Address of TWMF (2, 5, 10) in C-0002

C-0002	Initial address	180
C-0002	Header length	30 (600 BYTE/24 = 25* → 30* (1 record))
TWMF	Initial address	240

Relative displacement

$$(2-1)* 17 \times 17 + (5-1)* 17 + 10 = 367$$

Absolute displacement 817*

(* 1 unit = 8 x 3 = 24 BYTE, 1 record = 24 BYTE x 30 = 720 BYTE)

TWMF (2,5,10) = (X-cor, Y-cor, Z-cor)

at location 817*

In BRISTLAN statements, either expression - TWMF (2,5,10) or TWMF (I,J,K) - is possible if subscripts I,J,K are predefined in previous statements. The real coordinates are extracted from the file automatically through the data management system attached to the BRISTLAN processor. The revised form of data and the attribute code in SD in Fig. 3-6 are described in later sections of the Revised BRISTLAN.

3.2.6 BRISTLAN LANGUAGE and Capability

3.2.6.1 Statements

A BRISTLAN statement is described as a sequence of BRISTLAN vocabularies, which are classified into the following five fundamental items:

- a) STATEMENT NUMBER
- b) CONTROL WORD
- c) SYMBOL
- d) DEFINITION WORD
- e) OPERANDS (1 ~ 5)

The general descriptive format is expressed as follows. The first four items are in restricted form and the operands in free form:

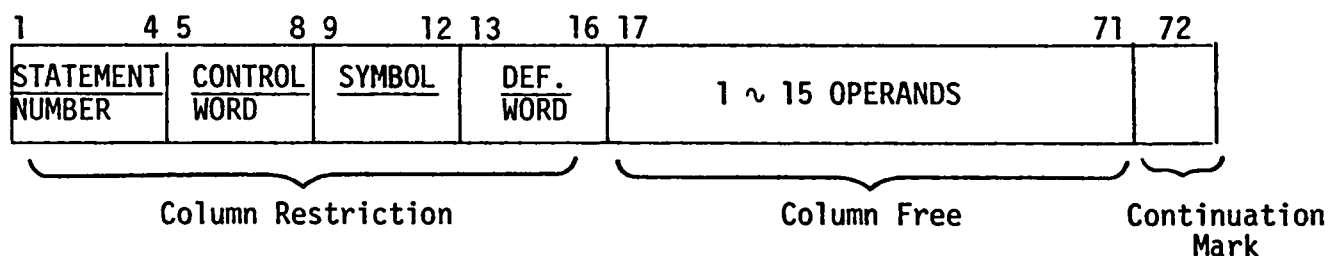

Statements fall into four categories:

- a) CONTROL STATEMENT
- b) GEOMETRIC STATEMENT
- c) SPECIAL STATEMENT
- d) LOGICAL STATEMENT

For figure definition, the coordinate system should be defined first and then the shapes of figures are prescribed as a sequence of GEOMETRIC STATEMENTS. The motion portion of GEOMETRIC STATEMENTS contains both machine dynamics and geometry which is edited into the original figure file, whereas the definition portion of them specifies working figures with symbols which are used later to define motion statements. In turn, the processor has two figure tables in it: the working figure table and the motion figure table (Fig. 3-12).

3.2.6.2 Basic Elements of Figures

Points, Figures and Variables are available in statements. The initial capital letter of symbol identifies its attribute.

P : 2-dimensional point

T : 3-dimensional point

S : Straight line

C : Arc

F : Figure (Combined elements of S,C)

I-N : Integer

W : Character

R : Instruction of data read

(A): Scalar

They should be always symbolized first by the above capital letters as reserved characters, which are meaningful for the BRISTLAN COMPILER to interpret.

3.2.6.3 Expression of Figures

1) Direction of Figures

Every figure has direction so that it is expressed as a vector.

2) Classification of Figures

An element of a figure is referred to as a "Segment", which is either a straight line or an arc. A series of segments compose a figure.

a) Straight Line (S)

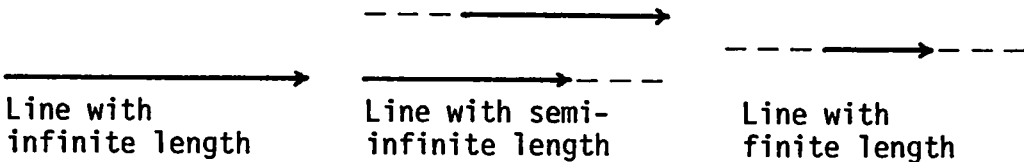

b) Circle (C)

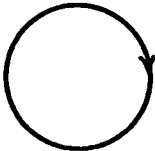

Whole circle



Semi-circle



Arc

c) Figure (F)



Curve
(Arrayed points)
Interpolation problem



Combined elements
(S and C)

3) Region

The left-hand region| facing toward direction of motion is specified to be positive. Consequently, the inside region of a counterclockwise circle becomes positive. This convention results in the convenience of automatic calculation of net area of a closed figure.



Net area of a closed figure

4) Distance

In the same way as the definition of region, the sign of distance makes sense in distance. If a point exists in the positive region of a figure, the distance normal to the figure from the point may be measured to be positive.

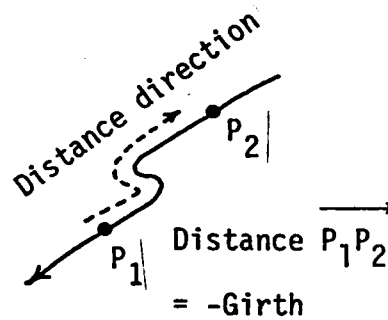
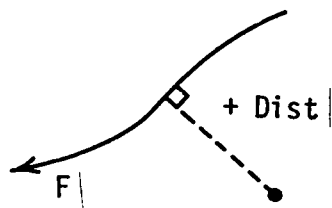

5) Radius of an Arc

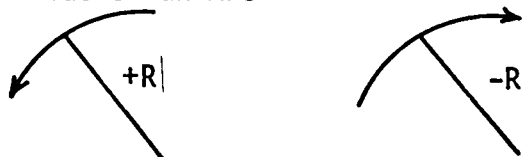

A counterclockwise arc has positive radius.

6) Angle

A counterclockwise angle is measured to be positive. Usually, the degree is used as a unit of measure.

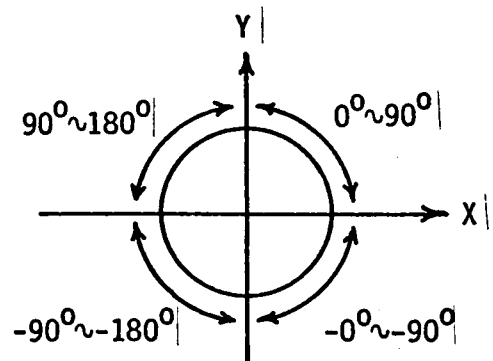

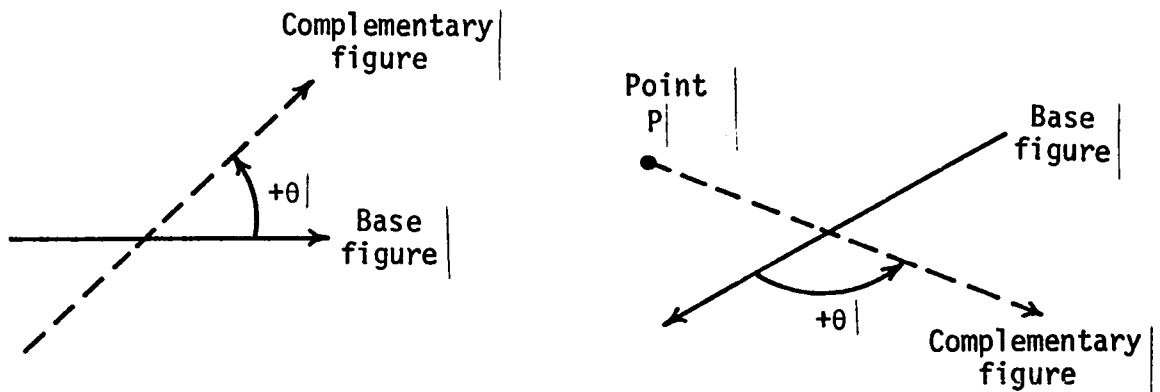

A positive angle is defined to be counterclockwise from base figure to complementary figure.

3.2.6.4 Classification of Statements

CONTROL, GEOMETRIC, SPECIAL and LOGICAL STATEMENTS are shown in Table 3-2 and Fig. 3-4.

GEOMETRIC STATEMENTS are predominated by either of two different CONTROL words: one is a NON command which is used only for definition of the element of figures and the others are MOTION commands (CONT, LAND, MARK, MEMO, HOLE) which imply execution of editing figures into the original figure data file. Since the sequence of MOTION STATEMENTS specifies the cutter path or drafter path of the hardware, the direction of a line as a vector and its descriptive sequence in the editing procedure are of great significance.

3.2.7 Internal Expression of Figures (Segment Lists)

Fig. 3-7 shows internal expressions of the basic figures in forms of the Segment List. Note that every basic element such as Straight Line, Arc, Character and Drilling Hole, is expressed by 5 words as data parts and an attribute word (in case of drilling a hole, the last digit represents the number of holes). To maintain accuracy in figure processing, each word in the Segment List has double precisions except an attribute code with a half word length. It should be strongly remembered that in figure processing the accuracy of data is so important that internal system design should be

concentrated on maintaining accuracy during execution. For instance, let us consider modifying the line shown in Fig. 3-8. First, cut it short at both ends, change its direction ("Back") and then "Parallel" it with a certain amount. Next, reverse and go back to the original line. As shown in Fig. 3-8, if the line is expressed in a form of the Segment List it is perfectly reversible with sustained accuracy. However, if the line is expressed by both end points there is no longer any guarantee that it will remain accurate. Since the accuracy of the angle between two points obviously depends on its length, if the points are very close to each other, the angle loses accuracy rapidly. This error accumulation causes very serious problems in MOTION execution. One such problem might be change of sign of an Arc radius, which implies the change of direction of the arc and sometimes leads to no intersection between two figures. Again it sometimes violates "error window" role in drafter; if data exists within it the interpolation mechanism of the machine loses its control.

Execution of MOTION might be no longer possible to continue and be stopped with the error message, "No intersection between the figures". In this case it is beyond control by part programmers. This is one of the most severe difficulties for the processor.

In general, there are two ways to express a given curve in internal forms. One is to express it as a sequence of points and connect two points by either a straight line or an arc, which leads to interpolation problems which limit accuracy. Another is to express it in function type and hold its parameters as figure information. APT belongs to the latter type. The advantage of this type is that it can exactly express high level geometric curves such as parabolas, even if given only minimum information, a few

functional parameters. Instead, internal processing for intersection calculation of interrelated figures becomes much more complicated as a whole, whereas the former type is concerned only with two elements, straight lines and arcs. In turn, APT is a more sophisticated language as far as internal algorithm of figure processing is concerned. However, from an engineering point of view, the shapes of superstructures of bridges are simple enough to be expressed by either straight line or arc, even though, in a global sense, roads are sometimes on a closoid curve. Presumably such a complicated geometrical positioning problem might be shared with another independent subsystem as a preprocessing matter: this concept yields the ROAD subprogram in the BRISTLAN system.

The change of objective from the machinery parts dealt with by APT to structural parts in the civil engineering field gradually changes the system concept. The emphasis and interest move from accuracy of products to efficiency and capability of dealing with multiple jobs simultaneously by a single part programming. In turn, the internal emphasis shifts from sophisticated algorithm of figure processing to the data management system. Branching commands, GOTO, IF, LOOP and reference to Secondary Data (SD) by subscripts in BRISTLAN enable the system to deal with multiple jobs with a single part programming. The more complicated the organization of the structural member system is, as in the case of building frames, the more important the data management system is, in comparison to net figure processing algorithm.

3.2.8 Configuration of Processors

The BRISTLAN processors consist of four parts which are originally written in FORTRAN and/or ASSEMBLER, and operated under the IBM 360 and 370 systems. Fig. 3-9 shows their procedures as a whole.

3.2.8.1 Compiler Processor

This checks correctness and completeness (syntax) of input data part-programmed, and then converts literal card images with an 80 byte length into a packed decimal code with a length of 16 bytes. The packed information is like the object module of FORTRAN and may be stored in the MACRO Library as a built-in subprogram for common use. Fig. 3-10 shows an example of a syntax check using the DECISION TABLE, in which a detective algorithm of descriptive error is arranged. For instance, if each rule is expressed in the form of a Data Statement, then its error detective algorithm becomes very simple.

3.2.8.2 Linkage Editor Processor

If necessary, this links subprograms in the Macro library with the main program part-programmed by users. Usually, the Stack⁹⁾ technique as shown in the network execution is very useful for subprogram calling. Each subprogram is followed after the main program and accumulated one by one and then its initial address is remembered by the Linkage Editor (Fig. 3-11). At the calling point in the main program, its branching and returning addresses are set up for execution. Besides this, the argument's address in the subprogram should be arranged also. In figure processing their communication is so complicated that as a result of execution in the MACRO Library, the figure table may be returned as well as scalar arguments. For simplification, the subprogram nest is limited only once. In turn, MACRO cannot call MACRO again.

3.2.8.3 Figure Processor

This produces N/C original figure data. The input to this processor is the object module edited by the Linkage Editor. It should be noted that it is possible for the processor to access and retrieve 3-dimensional coordinates data in the Secondary Data file (SD file) and automatically

transform them to 2-dimensional data on the PLANE domain predefined by another Command.

The figures are generated according to a sequence of MOTION statements and filed in the form of a "Segment List", with identification of PNUM (Piece Number less than 16 letters in length).

Fig. 3-17 shows an example of internal forms of figure processing, especially of the Segment List. Regardless of either Definition or Motion statements, Figures are always registered in the Segment List Table and the Symbol Table possesses its initial address as well as its data length. The Edited Segment Address Table (Fig. 3-12) also holds pointers to the Segment List Table as a result of Motion execution and finally Segment Lists only associated with it are filed out. Of course, the total amount of the Segment List is limited to 300 since dynamic array is not available in the processor.

3.2.8.4 Postprocessors and N/C Machine Information

This converts the "Segment Lists" to each N/C machine code. Unfortunately, the codes are not consistent in every N/C machine tool. This inconsistency means that users are always obliged to make an individual postprocessor for each tool.

Fig. 3-13 through Fig. 3-15 show N/C drilling and drafters codes used by NKK. The basic elements for an N/C controller are Line and Arc, whereas some drafters (Fig. 3-15) have the capability to deal with parabolas. The interpolation mechanism has a great influence on accuracy as well as on the feed speed of the movement, although these two items are contradictory requirements. Feed speed and accuracy are so important for the daily working schedule of the machines and for quality of products that each mechanical capability is ordered through negotiation and is usually specified in clauses

in a contract with the makers. It seems that the difference of N/C machine codes results from the differences in the mechanism in each machine. In turn, minor changes in the codes are apparently unavoidable.

3.2.9 Application to Bridge and Coding Examples

1) Example 1 (A simple pattern with standard statements)

Fig. 3-16 shows a part programming example written in BRISTLAN, in which SLOI symbolized by "F" represents a MACRO of a non-closed type of shape. Slot "F" is defined by CALL statements without MOTION, in which related arguments in operands are transmitted to the MACRO as a set of sizes of corresponding shape. "F" is used in the MOTION statement, CONT, twice by MOVE which transfers the original figure to the position specified in the related operands. CONT and LAND specify outside and inside edge lines respectively: the former in counterclockwise direction and the latter in reverse direction. Consequently, this convention results in automatic calculation of the net area zoned by the prescribed edge lines. STPT and ENPT define initiation and termination of motion of the N/C machine tool. Note that in N/C flame cutting, ignition and travelling path of the torch are of great significance since the process causes distortion of plates due to residual stresses. PNUM initiates the job and identifies the name of job. The characters in PNUM also turn out to be a part of the figure as shown in Fig. 3-16.

2) Example 2 (A Base plate with output of Segment Lists)

Fig. 3-17 shows a case of using LINK MACRO which implies direct MOTION. Base plate "F" has already been completed originally in the library. What the part-programmer should do is to add marking lines and drilling holes on it. Since the main program has already been written, there is no need to CALL and then MOVE it as shown in the previous example.

Fig. 3-18 shows the result of the BRISTLAN processor, a sequence of Segment Lists. Segment List codes 121, (122), 123 imply figure categories (CONT, LAND, MARK). For checking convenience, starting point (X_1, Y_1) and ending point (X_2, Y_2) of each segment are calculated: In cases of CONT and LAND the points should obviously be continuous since they consist of shapes of a closed nature.

3) Example 3 (Full web sway bracing)

Fig. 3-19 shows a typical example of development and drawing of a sway bracing in a bridge, based both on plan and profile design drawings. Since the sizes described in the design drawings are not exact, 3-dimensional coordinates which indicate exact positions in the structural system, Secondary Data (SD), are required for figure processing. TSU1, TSL1 and TSC1 declare the symbols associated with the corresponding Secondary Data in file. Automatic projection onto the plane defined by PLN1 in which the web of sway bracing might exist can be completely established by the BRISTLAN processor. Consequently, all users need not worry about their coordinates transformation at all, once the plane is surely defined. Again the load of jobs is completely shared with three subsystems, ROAD, BRMESH and BRISTLAN, independently.

4) Example 4 (Coordinate transformation for erection in yards)

Fig. 3-20 demonstrates a way of computing elevation in a girder system for the purpose of erection in yards. For convenience of erection working in yards, suppose the girder G1 is set up in such a way that both supports A and B are at the same level. Consequently, the other girders G2 and G3 should be turned around about A axis together with G1. Secondary Data is also available in file. Being different from figure processing, not as usual, the only output is printing out of the coordinate transformation indicated by

a WRIT command. Note that for treatment of triple subscripts in SD, two Loop nests (LPST, LPED) are used. TRAS converts 3-dimensional coordinates to 2-dimensional points "P" on the prescribed plane.

5) Example 5 (4 web drawings as multiple jobs)

Fig. 3-21 shows an example problem of 4 web drawings as multiple jobs by a single part programming. Secondary Data available is again in file, pointing to the upper, center and lower positions of the webs, designated as TWUF (I, J, K), TWMF (I, J, K) and TWLF (I, J, K), respectively. Subscripts I, J, K indicate span number, girder number and station number of the web positioned by such things as stiffeners attached to it. Since the stiffeners are attached to the reverse side of the G3 and G4 webs in comparison to G1 and G2, the TURN statement is effective in the same algorithm of part programming. Because gas cutting changes the dimensions due to melting, its travelling path should be slightly outside the exact shape. Note that they are 2mm greater in width and 20mm greater in length. The cutting width of the torch is considered to be 1mm in this case. Fig. 3-22 shows the whole part programming.

6) Example 6 (Drafting)

Fig. 3-23 demonstrates three examples of drafting: a web, sway bracings and gusset plates nested in a plate of regular size. Positioning of the gusset plates in a plate was done by hand. 1/10 scale drawings are enlarged up to full scale and printed out onto real plates by means of an EPM device, then supplied to gas cutting by hand.

3.2.10 Revised BRISTLAN System

As mentioned in the previous section, one year after the establishment of the first project, a rapid increase of production jobs again forced a

revision of the whole N/C system in 1972.

Fig. 3-24 shows the outline of the revised system flow. The topical revolution might be intervention by Third Data (TD) between Secondary Data and the BRISTLAN processor. TD exists in the form of 2-dimensional coordinates instead of being 3-dimensional in form as in the case of SD. In turn, the load of coordinates transformation which was on the shoulder of the BRISTLAN processor has been released to the TD Program instead. Furthermore, a variety of development problems existing in template shop operations have been concentrated in it. The concept of sharing jobs independently leads to a form of integrated system. Each subsystem in revised BRISTLAN (Fig. 3-24) keeps its status at the independent level: their interrelationship is connected through the individual file. Each of the input forms to each processor is a variety of Commands resembling the previous BRISTLAN, except the input to the post-processors. By means of a Graphic Monitor, an interactive editing method with the computer has been under development for nesting plates.

At the same phase, the BRMESH program has been revised to further expand its capability for general purposes. Consequently, the data format was changed to a new one; from 3 words in length per data to 5 words, including an attribute code (ACODE) and a link code (LCODE). Fig. 3-6 shows the features of the data structure. An attribute code has been shown to be of great use in handling SD. First, since an attribute code indicates the point's status such as at end, at support and/or at web cut, the TD program is able to edit the data automatically with minimum input from the users. Second, it allows the automatic drawing of general views, such as profile or plane views of girders, for inspection at the phase of BRMESH program according to the token of the attribute codes. Third, it also enables the

the production of shop operation sheets such as material lists which exactly indicate the maximum rectangular sizes of plates that must be ordered, considering curved shapes due to camber or other profile effects.

Note that an ideal integrated system also has a few weak points which may be considered to be disadvantages. Once an original design change occurs or some mistakes are found in the middle of a job, the corresponding files should be updated immediately from the origin, propagating to the next upper level files. In conclusion, even minor change of the origin requires updating every file without skipping intermediate files. This requires much work to accomplish. In turn, the number of job steps, and hence the number of integrated subsystems, should be held within reasonable limits.

3.2.11 Effects and Conclusions

After determining that BRISTLAN was capable of working well through several actual applications to the real structures of bridges, the BRISTLAN system was adopted and built in as a part of the regular procedure of the fabrication process at the Tsu Works of NKK in 1969. In a revised revision it is capable of fabricating almost 2,000 tons of steel jobs a month. The daily jobs were established by means of teleprocessing communication between the large computer in the center, IBM 360/65 with 768 KB memory, and the terminal computer in the Yard, IBM 1130 with 8 KB memory, until 1973 when the large computer was settled in the Yard.

At the beginning of the project, it was enthusiastically expected that human labor would be reduced through introduction of the new computer system since it would replace human labor with computer operations. However, the system did not affect as great a reduction as had been expected. Furthermore, it required successive great efforts of a number of people concerned to

establish its compatibility with the daily routines until it became a built-in procedure in the Yard. The real potential energy which has sustained the new N/C system is apparently the confidence and pride of the people involved, who see a new technology beyond the difficulties.

From an engineering point of view, further study should be focused upon the following concerns:

1) Patterns of shapes and standardization

Standardization is so important in any cases for ease and efficiency of production that engineers always discuss consistency and simplification of design, sometimes up to the formulation of specifications. As indicated in early BRISTLAN, standard patterns in the common library amount to as much as 56 types. Note that they are limited within local portions of shapes in structures. If they are expanded to relatively global proportions, they may gradually lose their adaptability for common use, although they are still crucial for daily production. The point is to make the best use of the two categories: one is general patterns common to everything, like built-in functions; the other is particular patterns proper to a special job for temporary use. In any case, capability of registration and accumulation of past experience are of great importance in system design.

2) Inspection of shop drawings

The conventional formal inspection by agency was based upon the floor drawings system. The new N/C shop drawings system gives rise to reconsideration of the existence and the role of this inspection. Specifically, the following items should be evaluated:

- a) Contents and significance of shop drawings
- b) Environments in working

- c) Accuracy
- d) Interrelationships among design, fabrication and shop drawings
- e) Significance of formal inspection at the stage of shop drawings

From a computer processing point of view, the following can be concluded:

a) Internal forms of figures in figure processing are of great importance. The Segment List in the BRISTLAN processor is an effective expression for holding accuracy and modifying the segment without losing accuracy.

b) In figure processing of bridge parts, straight lines and arcs are considered to be basic elements sufficient to express the shapes of structures exactly. Simplification of the expression by two basic elements leads to compact forms of algorithm in processing.

c) Instead, the more complicated the organization of the structural member system is, as in the case of building frames, the more crucial the data management system is, in comparison to net figure processing algorithm.

d) The Revised BRISTLAN configuration resulted in a type of integrated system as a whole, releasing the concentrated loads on the BRISTLAN processor to a few supporting subsystems. However, the number of job steps and the number of integrated subsystems should be in balance, considering the work of updating files when design changes are required.

3.3 N/C System in Building Frames

In 1971, one year after the success of the new N/C system in bridge construction, the second project was started. The application to building frames led to a new type of system different from the original BRISTLAN.

In this paper, the whole scheme and the basic concepts are described briefly by looking at the environments associated with the fabrication of building frames.

3.3.1 Environments

1) Fabrication and Shop Drawings

The percentages of work loads in fabrication and shop drawings occupied in building frames are completely reversed compared to the case in bridge construction. 70% of the total amount of drawings is occupied by fabrication drawings (Table 3-3). The preponderance of work moves from shop drawings to fabrication drawings in case of the building frames.

The figures shown in Table 3-3 imply that if we expect complete efficiency in the new system, the N/C system should cover both regions beyond the limit difficulties which had existed in the conventional work procedures. Consequently, if the N/C system were to penetrate into the area of fabrication drawings, the concepts of the drawings as well as the content of expression in the drawings would have to be revised and reorganized to new forms suitable for data processing in the computer. This requirement has changed the conventional concept of drawings which is based on the principle, "one structural scheme in one drawing", to a new concept of drawings, "a drawing based on the organization of structural elements".

2) Material Handling

Material handling is so important that it is considered to be one of the critical problems in building fabrication. Fabricators sometimes say, "First, material, Second, N/C system". This results from the tremendous number of small pieces which compose the structural members. Estimating the quantity for ordering and the assembling process are crucial for fabrication. A new N/C system which is capable of covering material handling is apparently the inevitable outcome in the fabrication of building frames.

3) Section Handling

A variety of standard milled sections occupy most parts of members in a building, as shown in Table 3-4. Relatively small scale members and standardization of design enable the use of standard shapes of sections instead of custom made, built-up sections. Since BRISTLAN is obviously designed for 2-dimensional plates, another processing technology is necessary for section handling.

4) Property of shapes in Building Frames

Most members in a building are composed of relatively small members with simple elements of shapes, mostly with straight lines. The original shape of a member is rectangular. Through cutting its corners for fitting with other elements and drilling holes for connections, it is modified to a slightly more complicated figure. It is almost impossible to find curved elements in building frames except in a few special cases. These simple shapes do not require high level figure processors like BRISTLAN, although it is still available in building. Coordinates of structural frames involve point location of spaced meshes, linearly spreading in 3-dimensional directions, in the form of a box.

Also, simplification of coordinates does not require high level preprocessors like ROAD and BRMESH in the Bridge system. Instead, standardization of patterns is definitely required in the form of a standard library like MACRO. Thus, decreased need for a coordinates file is traded for increased need for a pattern library. Furthermore, connection parts and branching points of structural trees should be focused on details: cutting edges, splices, drilling holes, and gusset plates. These details occupy most aspects of the job.

3.3.2 System Flow

Table 3-5 shows an outline of system flow in the building process.

The major part is composed of five jobs:

- a) Material handling
- b) Coordinates handling
- c) Section handling
- d) Plate handling
- e) Postprocessing

New items added to the building system are a) and c), in contrast to the bridge system. For the two new added jobs, the MRG (Material Report Generator) and the BRISTLAN 2 programs were established respectively. They are also capable of referencing to the appropriate files, the MRG Table and the MENU Library, respectively.

The former file stores a variety of milled sections sold on the market by mill makers, such as wide flanges, in the U.S.A. The latter file stores standard patterns common to regular shapes in rigid forms in the sense that the sizes of the appointed shapes are not changeable through parameters like BRISTLAN MACRO arguments; "MENU" is not custom-made to a flexible form.

For the purpose of Coordinate handling, the SDPC (Secondary Data Production Command) program was constructed. It has the same SD data structure as that produced through ROAD and BRMESH, although the input form and processing algorithm are quite different, considering the feature of box-type coordinates in building frames.

3.3.3 Organization of Structural Members

Fig. 3-25 shows organization of structural members. This hierarchy is still applicable to all types of structures. A structure is composed of three basic levels of elements:

- a) Erection Block
- b) Block
- c) Piece

"Piece" is the lowest level element, a set of which composes the next level element, "block". Again, blocks are assembled through fabrication into an erection block which is considered to be a unit transported from shops to construction spots. Note that blocks BK55 and BK50 shown in Fig. 3-24 are common blocks used both in ICC3 and ICC4 of the erection block. The feature of common blocks simplifies the jobs and reduces the assembling labor. Each piece has a keyword seven digits in length: the first two identify the LOT in the assembly line, the second two indicate the block, and the last three order the sequence numbers in the block.

The keyword identifying the piece is the basic information for sorting of material in MRG and is referenced by BRISTLAN 2. The concept of structural hierarchy is also applicable to the organization of the new fabrication drawings system. In conclusion, erection block and block become a unit of each level of drawing, based on the principle, "drawings are made according to organization of structural members" for the purpose of ease of data processing.

3.3.4 Fabrication Flow

Fig. 3-26 demonstrates a schematic flow of the new N/C system in building construction, including material handling. Fabrication drawings contain skeletons, erection block drawings, block details and fabrication standards: the first are general views used for erection at construction sites, the second and third are structural components previously described, and the fourth indicates the details concerning shop operations such as welding standards for each thickness of connection plates. Fabrication standards predominate any erection block drawings and block details except

in a few special cases. In a computer sense, structural details concerning shop operations both in erection block drawings and in block details are pointed out from the tables in the fabrication standards.

Structural frames in buildings fall into three categories: column, beam, and truss. Because of the difference of cross-sections in each case, the N/C processing takes different branching. In general, the column is characterized by the most complicated features: the column itself is built up and stiffened against buckling, and furthermore has several wings for connections with beams. In this case, BRISTLAN is the best fit.

The beam shows the most simplified form without cumbersome parts. Most of them are derived from milled sections, seldom from built-up sections. Sometimes at the stage of mill works, for instance, in the fabrication yards of H section at the Fukuya Works of NKK, drilling holes and edge cutting by cold saws have been performed automatically under numerical control. Partly so that it will be useful at the Fukuyama Works, BRISTLAN 2 was developed with capability for section handling. Flame cutter control is also available as a result of the definition of complex parallel lines in BRISTLAN 2. Rather complicated parts in truss structures occur at the nodal points from which branching members radiate in arbitrary directions. Some of them are curved when they support roof structures. Since they resemble bridge girders, it is desirable to set up a coordinates files like the SD file in the bridge system. The SDPC program can calculate coordinates of structures in the same forms as the SD produced by BRMESH and supply the SD file to BRISTLAN part-programming. At the same time it is capable of listing the gusset sizes and corresponding information for template shop operations.

Finally N/C information is formatted in "Segment Lists" no matter which processors are concerned. The original format is consistent for every post-processor.

3.3.5 Material Handling

Input to MRG program is of two types:

- (a) Piece data with a keyword
- (b) Network relation between erection blocks and blocks (Fig. 3-34)

(ex)(a) A piece

SH	428 x 407 x 20 x 35 x 10,800	(2)	SM50A	CB07	SH01	02A2001
└───┘	└──────────────────────────┘	└───┘	└───┘	└───┘	└───┘	└───┘
type	sizes	NUM	Quality	Block	Piece Mark	Keyword

(ex)(b) Network

└───┘	---	└──────────────────────────┘
ICC3		SH14, SH09, SH04, BK40, BK55, BK06
Erection block		Blocks

Referencing to the Section Table in file, for instance, SH 428x407x20x35 becomes a keyword to the Section Table. As a result of sorting, the following outputs can be extracted next:

- a) Erection blocks lists
- b) Block lists
- c) Lot lists
- d) Fabrication lists (weights, painting area)
- e) Shop operation lists (drilling holes, cutting and marking girth)

Tables 3-6 and 3-7 show some of the above lists.¹⁰⁾

3.3.6 Coordinates Handling

In 1969, J. W. Melin published a concept of matrix operation in a paper entitled, "Problem Oriented Subroutine Translator (POST)".¹¹⁾ The type attributes here are ELEMENT, VECTOR, MATRIX, SET, and ARRAY. The basic concept results from the necessity of array data processing in matrix analysis

to move from memory in the computer to secondary storage as a set with a designated length. Simple operations between two matrices such as adding, subtracting, multiplying, and dividing are allowed there also.

The SDPC program is based on a concept similar to that of POST. Fig. 3-27 shows a box-type structure like a building. Suppose that P_1, P_2, P_3, P_4 , are expressed in vector form, then the vector on the second floor is coordinated adding h_1 to the z-coordinates of the origin. Likewise, the vectors on each deck are calculated in a simple operation. Similarly, street "a" is expressed in a matrix form. Again, street "b" is coordinated adding d_1 to the x-coordinates of the origin. The general form of the coordinates is:

$$\text{MATRIX (I, J, K) = (X, Y, Z)}$$

where I, J, K express station numbers in directions X, Y, Z, respectively.

This is exactly the same expression of Secondary Data (SD) as mentioned earlier. SDPC commands generate new coordinates based on original vector values through simple operations. The basic instruction is:

$$V_0 = a * V_1 \pm b \cdot V_2 \pm C \cdot I$$

where V_0, V_1, V_2 : vectors

I : unit vector

a, b, c : scalars

In the case of curved elements, coordinates should be generated by another algorithm and stored in the SD file through a READ Command in the SDPC.¹²⁾

Fig. 3-28 shows another capability of SDPC, in which it calculates the sizes of gusset plate and corresponding dimensions based on the SD file.

The lists are used for template shop operations.

3.3.7 Section Handling and BRISTLAN 2

Table 3-8 compares BRISTLAN 2 with BRISTLAN 1 (the original BRISTLAN). BRISTLAN 2¹³⁾ drops several sophisticated features involved in original BRISTLAN. One of them is elimination of branching capability in algorithm. Loss of looping capability also reduces efficiency of part-programming, although the feature is in natural form in contrast to other figure processing languages.

As a matter of convention, a variety of sections commonly used in the market should be set up with their coordinate systems in each plane. Fig. 3-29 demonstrates some of them. The convention should be consistent from software through hardware, since machine tools move according to their coordinate systems. For instance, a drilling machine with multiple spindles on three planes of an H section should be controlled simultaneously.

Fig. 3-30 shows an example of coding written in BRISTLAN 2. First, the figure pattern is defined as "MENU", then it is copied at designated positions. PNUM also is identified by a keyword which relates to the material master file. Fig. 3-31 shows pieces nested in a plate.

3.3.8 Effects and Conclusions

Table 3-9 shows the result of N/C building production in contrast to bridge construction. The figures in Table 3-8 tell us that, as expected before analysis, the number of the same piece available for repeated use, indicated by ratio of drawings weight to EPM weight, is almost three times in building, whereas it is only 1.2 times, on an average, in bridges. On the contrary, weight per piece is remarkably light, only about 20% of that in bridges. In conclusion, the number of pieces concerned with N/C

processing increases almost twice ($1.2 \times 5/3$) in comparison to a bridge of the same weight. This seems to be a reasonable figure, even though data for comparison is limited, and holds the possibility of success in building construction.

However, at that time, the figures gave the impression to those involved that severe difficulties might exist on the way to realization of the new system. So far, material handling with MRG has been operated according to the law, "Materials first", successively and successfully.

From an engineering point of view, the following conclusions can be drawn:

1) Erection Block, Block and Piece are basic elements and organize the structural scheme. This concept is very useful for data processing in the computer, both for material handling and fabrication drawings. The interrelationship among the elements is expressed by a network tree structure in compact form.

2) As far as the N/C drawings system is concerned, further study is required considering the features clarified at this step. Pieces in building are expressed as "a variety of small scale elements with simple straight lines".

3) The N/C system should cover both fabrication drawings and shop drawings beyond the limit which has existed in conventional jobs.

From a computer point of view, we can draw the following conclusions:

1) The emphasis of aystem design moves from N/C figure processing algorithm to data management system. The features are transient:

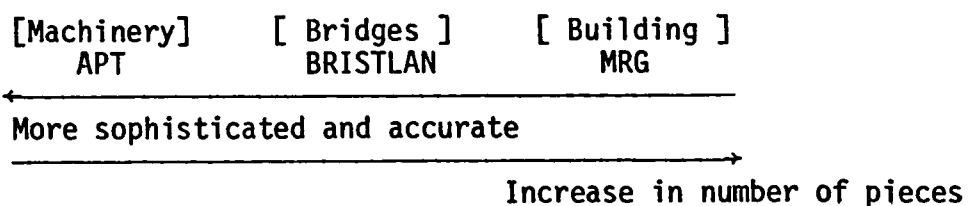

2) The original idea of matrix operation described in POST¹¹⁾ has led to a sophisticated data management system working in the POLO system at the University of Illinois.¹²⁾ Also, as shown in the SDPC program, matrix operation through file is so important that it polarizes the computer system into two extreme parts: one is the data management system and the other is problem oriented processing itself.

The system flow analyzed in bridge construction shows a type of integrated systems correlated vertically step by step. In contrast, the system flow in building construction indicates a type of total system, correlated horizontally as if the subsystems were shaking hands. In any case, the data management system interconnects subsystems through files which are required by all of them.

3.4 Future and Proposed Scheme

3.4.1 Information Flow in Design and Fabrication

Fig. 3-32(A) shows a feature of information flow in design through fabrication. Original information in the design is derived from its structural scheme and environment surrounding it and is referred to as "parameters" in the network, as defined earlier. In design, the amount of information increases rapidly through the analyzing process until design work terminates. At the end of design it reaches a maximum, including design drawings, design sheets, material lists, and so on. Based on the results of design, fabrication work begins. In contrast, information converges towards a target through the organizing process. In a data management sense, it is desirable to grasp data in hand at the critical station, or at least at the station where the amount of information is considered to be relatively small. However, in reality, we grasp data at

the maximum station, simply because design work terminates there and fabrication work begins at that point. For instance, the BRISTLAN system in bridge construction starts with an N/C definition of a single piece and the MRG program requires the same unit, which is considered to be a minimum of components but yields a maximum amount of information.

At the beginning stage of the project, this attitude is apparently reasonable in real jobs from a fabricator's viewpoint since every structure results in the same type of information regardless of its design process and of the type of structure, although the amount of information reaches maximum there. In other words, it is a reasonable and usual strategy to occupy the top of the hill and govern it first so as to look over the valley and the ways leading to and branching from there. In any case, a longitudinal step from the origin consists of a type of integrated system as a scheme of specialization and a transverse relation, as if they were shaking hands, and shows a type of "total system" as a scheme of generalization.

The topological expression by network is modeled in Fig. 3-32(B) and (C). Note that the direction of flow in tree structures faces towards a target; the flow in the analyzing process is diverging and that in the organizing process is converging. This feature is of great importance, as described later.

3.4.2 Fabrication Network

Fig. 3-33 demonstrates an example of a network expressing the data hierarchy of structural elements, which is reformed from Fig. 3-25. The network shows a converging type resulting in a structure. The nodes represent "substantial" existence in the real structure and also have "shadow" parts associated with the "substantial" parts under the name of node information, as shown in Fig. 3-33. The contents of the table are a few examples in a

conventional sense and of course changeable according to the fabrication methods reflecting recent technology. A node contains a variety of information. First, it contains both dependents and independents related to the flow through the network. Second, it includes drawing information such as plane, profile, and side views. They are all data projected in 2-dimensional form on each plane in such a way that the "shadow" depends on the direction of the spotlight relative to the "substantial". Third, it accompanies management data used for shop operations such as weight, surface area, cutting length and drilling holes.

Furthermore, Fig. 3-34 focuses attention in detail to drawings of Blocks and Pieces of the structure. In a conventional sense, a Block has three types of pictures: plane, profile, and side views. Originally, each of them derives from three components (Fig. 3-34): a set of Pieces as substantial structural attributes, design data and coordinate data. A drawing of a Piece is also generated, for instance, by the BRISTLAN processor, from three components: part-programming, MACRO patterns and coordinate data. In this case it obviously has only a plane view without profile and side views.

3.4.3 Data Communication

Fig. 3-35 sketches a general flow of information among Subspaces which represent, for instance, designer, fabricator and material supplier. Simply speaking, their final purpose is constructing a structure which has been contracted. However, they are interested in different forms of expression as a part of the "shadows" of the structure. For example, the designer is interested in design sheets and design drawings, whereas the fabricator is interested in the fabrication and shop drawings as well as shop operations

lists. In contrast, the material supplier is interested in material lists sorted by types, sizes and lots on time. The solid boxes between subspaces in Fig. 3-35 imply converters necessary for transformation.

Suppose a change of data occurs in A-Subspace. Consequently, it should be propagated to other subspaces instantaneously. The internal mechanism of propagation is complex. A change or changes in parameters may or may not affect whole procedures. In the case of a relatively large structure, it is desirable to know which parts are affected and minimize reprocessing parts as less as possible.

3.4.4 Response to Data Change

Let us go back to Fig. 3-33 and Fig. 3-34 again, in which a tree structure and nodes are demonstrated. Suppose that the Piece with No. 1055001 is changed. Accordingly, Block BK55 anticipates the stimulus through its Ingredients table and then informs the upper level nodes, ICC3 and ICC4 in this case, of the change. The fact will be propagated through the "substantial" structural nodes up to the topmost. At the same time, the "shadow" parts should be affected correspondingly.

As mentioned earlier, there are two execution modes in the network: "SEEK mode" and "WARN mode". The originator of a data change, such as the designer, should be at least responsible for executing the WARN mode which results in turning the "void" flag in the node information concerned.

In turn, corresponding data with a "void" flag is no longer available in production until the SEEK mode is executed by people at another subspace. Each item in node information has a flag (Fig. 3-33) because, for instance, painters in the yard are interested only in the estimate of quantity of paint required. Furthermore, probably fabrication drawings are very

sensitive to change of design. They may execute SEEK mode for its revision repeatedly anytime design is changed. In contrast, the management list concerning shop operations may be generated only once or twice later at the stable condition. Clear division of SEEK and WARN modes in the network clarifies the responsibility of jobs in production and the freedom of time when they are executed.

This feature enables people in subspaces to grasp which parts are being changed and updated and get whatever results they want whenever they want them.

IV. SUMMARY AND CONCLUSIONS

The recent ten years have been a time of remarkable accomplishment in computer use in the field of structural analysis, design and fabrication works. However, there is a tendency that the fundamental study of computer methods on design and fabrication is behind the progress related to structural analysis. In spite of the great necessity of constraints processing as a part of the computer aided design system, general purpose computer aids have not been available so far, simply because of the diversity of the constraints information. This tendency of diversity of information is much more prominent in the processing of fabrication works. The complicated and cumbersome interweaving of the information has made it delayed to be developed for the practical use.

This study conducted herein has put great emphasis on the not-fully-cultivated fields, that is, the computer methods in design and fabrication from a fabricator view point.

The study is divided into three chapters :

1. Organization of Specification
2. Constraints Processing
3. Numerical Control System in Fabrication

Finally, a total system which covers the entire procedures of production works in design through fabrication is proposed.

Chapter 1 deals with the methods of representation, analysis, and expression of the specification in such a way that the specification can be uniquely,

completely, and correctly described. Then, a generation method of new specification text is proposed, based on the analysis of a few existing specifications.

A specification can be viewed at three levels :

(a) top level, (b) intermediate level, and (c) detailed level. The top level provides the overall organization of the text by hierarchically structuring independent bases for grouping the design criteria. The intermediate level provides for organization of the functional network used in evaluation of a particular criterion or set of criteria. The organization of provisions at the detailed level can be obtained by organizing individual decision tables. These analysis methods yield the reorganization methods of the draft specification into a complete form.

The design configuration consists of four major components :

(a) facility, (b) environment, (c) interaction, and (d) performance. Performance is considered to be an outcome of interaction between a facility and an environment. Consequently, these four basic arguments build the outline of the specification as an index. The planned and detailed sub-arguments associated with the above each major argument are useful for organizing a new outline index.

These concepts and techniques may possibly lead to automatic generation of specification text and to constraints processing in the design procedure.

Chapter 2 deals with conformance checking of proposed designs against a given specification. Well established specifications which are analyzed and organized by the methods mentioned in chapter 1 are readily applicable to constraints processing. As an example, an application of conformance checking to a

truss bridge is demonstrated on the basis of the AISC Specification.

The design procedures which are specified in the specification are expressed by networks, in which a node at a certain point is identical to a provision of the specification, and organizes a design criterion as a whole. The stacks technique is very useful for operation of the specification networks. The SEEK and WARN modes are powerful under the conditional execution for recycling jobs of the network since wasteful and duplicated calculations can be avoided at the subsequent execution.

Consequently, a model of constraints processing is proposed for general use. The system is composed of three major processors :

(a) Network Linkage Editor, which organizes the specification networks in a computer-processable form, (b) Data Manager, and (c) Executor, which accepts checking requests and controls stacks jobs of the networks. Based upon the proposed methods, flexible and general purpose constraints processing can be expected to be available, following the current specifications which may be updated according to the development of the relevant technology.

Chapter 3 deals with BRIDGE AND STEEL STRUCTURE LOFTING LANGUAGE (BRISTLAN) System which has been developed in Nippon Kokan K.K.. The contents are discussed from the following view points :

(a) figure processing as a form of problem oriented language (POL), (b) environment of bridge fabrications, and its application, (c) environments of building frame fabrication, and its application.

Numerical control system is very useful in fabrication of steel works, especially both in fabrication drawings and shop operations. In the case of bridge fabrication, figure processing language (BRISTLAN) becomes a nucleus of the N/C

system which is supported by several subsystems and is considered to form an integrated system from design through fabrication. The overall process of the system is formed of the major three processors :

(a) preprocessors, which mainly arrange the coordinate data so that they are available in the figure processing, (b) figure processor, which generates the original N/C information, (c) postprocessors, which converts the N/C information to each N/C machine code.

In contrast, in the case of fabrication of building frames, material handling and fabrication drawings become more critical rather than shop operation works which are important in bridge fabrication.

Consequently, the emphasis of the system design moves from N/C figure processing to data management system. The system flow in building construction indicates a type of total system, correlated independently of each other as if the subsystems were shaking hands. A data management system should interconnects the subsystems through files which are required by all of them.

As a result of the application to building frames, the data indicates that the small pieces of structural members in building and existence of a large amount of steel sections rather than plates make it difficult to complete N/C system in building fabrication, whereas the application to bridge has been completely succeeded in the real production works.

Information flow in design through fabrication is expressed by topological networks as shown in the organization of specifications. The amount of design information increase rapidly through analyzing process until design work terminates, whereas the amount of fabrication information converges towards a target

through organizing process. The nodes of the network represent "substantial" existence of the real structure and also have "shadow" parts associated with the "substantial" parts. "Shadow" data is considered to be the projected data of the "substantial" ; for instance, a profile drawing and management data used for shop operations such as weight lists, all of them are generated from the substantial structural data in selected formats.

This concept is very useful for data communication among Subspaces which represent, for instance, designer, fabricator, and material supplier, each of whom is interested in a different form of structural information respectively. Network organization of structural information, in which dependents and ingredients of the components are clearly specified and their relationship is clarified, let them know which parts are affected and updated due to changes of parameters in the overall scheme of the network so that they can minimize reprocessing of the updated parts as less as possible.

Network expression of structural information in design as well as in fabrication enables people in subspaces to grasp which parts are being changed and updated and get whatever results they want whenever they want them.

REFERENCES
(in Section I)

1. D.J. Nyman, S.J. Fenves, and R.N. Wright, "Restructuring Study of the AISC Specification", Technical Report of a Research Program, U of I, Jan. 1973.
2. S.L. Pollack, "Decision Tables: Theory and Practice", Wiley-Interscience, New York, 1971.
3. "Recommended Lateral Requirements and Commentary", Seismology Committee, Structural Engineers Association of California, 1974.
4. S.K. Goel and S.J. Fenves, "Computed-Aided Processing of Design Specifications", J. of the Structural Division, ASCE, Vol. 97, No. ST1, Jan. 1971, pp. 463-479.
5. S.J. Fenves, "Tabular Decision Logic for Structural Design", J. of the Structural Division, ASCE, Vol. 92, No. ST6, Dec. 1966, pp. 473-490.
6. R.N. Wright, L.T. Boyer, and J.W. Melin, "Constraints Processing in Design", J. of the Structural Division, ASCE, Vol. 98, No. ST1, Jan. 1971, pp. 481-493.
7. D.J. Nyman and S.J. Fenves, "An Organizational Model for Design Specifications", Report R 73-4, Department of Civil Eng., Carnegie-Mellon Univ., Sept. 1973.
8. J.R. Harris, J.W. Melin, and C. Albarran, "Technology for the Formulation and Expression of Specifications", Vols. 1, 2, and 3, A Report on Research Project, Civil Eng., U of I, Oct. 1975.
9. Y. Yamada, T. Takaku, K. Wada, and T. Maeda, "Computer Aided Design and Checking System", J. of Japan Civil Eng. Society, April 1974.
10. "The Specification of Highway Road Bridges", Japan Road Association, Feb. 1973.
11. "Manual of Steel Construction", AISC, Seventh Edition.
12. BOCA Article 14, "Sign and Outdoor Display Structures", 1974.

REFERENCES
(in Section II)

1. Steven J. Fenves, "Computer Methods in Civil Engineering", Englewood Cliffs, N.J., Prentice-Hall, 1967.
2. The American Association of State Highway Officials, "Standard Specifications for Highway Bridges", Eleventh Edition, 1973.
3. L.A. Lopez, "POLO II Programmer's Guide", CESL, University of Illinois at Urbana-Champaign, Feb. 1973.

REFERENCES
(in Section III)

1. Nils O. OLEsten, "Numerical Control", Wiley-Interscience, John Wiley & Sons, Inc., 1970.
2. T. Takaku, T. Watabe, "Drafters and Figure Processing Program", NKK Engineering Report, No. 45.
3. The APT Long Range Program Staff, "APT Part Programming", IIT Research Institute, Library of Congress Catalog Card Number 67-11876, 31674.
4. Japan Naval Architecture Eng. Society, Committee of Numerical Control System, "Numerical Control Technology in ship building", Feb., 1972.
5. M. Tanaka, T. Takaku, T. Watabe, T. GORIKI, "Numerical Control System in the Field of Bridge Fabrication".
6. NKK Steel Structure Division and Information Systems Division, "Report on Application of BRISTLAN System to Building Frames", April, 1971.
7. NKK Civil Engineering Division, "Report on Investigation of Total System in Bridge Design and Fabrication", Feb., 1974.
8. Ueno, Mikami, Tanaka, Kamemura, Maruyasu, "Total System in Bridge Design and Shop Operations", J. of Japan Civil Eng. Society, Feb., 1974.
9. Steven J. Fenves, "Computer Methods in Civil Engineering", Englewood Cliffs, N. J., Prentice - Hall, 1967.
10. NKK Steel Structure Division and Information Systems Division, "BRISTLAN, MRG User's Manual", April, 1971.
11. R.N. Wright, L.T. Boyer, and J.W. Melin, "Constraints Processing in Design", J. of the Structural Division, ASCE, Vol. 98, No. ST1, Jan., 1971, pp. 481-493.
12. NKK Steel Structure Division and Information System Division, "BRISTLAN, SDPC User's Manual", March, 1971.
13. NKK Steel Structure Division and Information System Division, "BRISTLAN 2 Grammar", March, 1971.
14. L.A. Lopez, "POLO, Problem Oriented Language Organizer", Computer and Structures, Vol.2, pp. 552-572, Pergamon Press, 1972.

Table 1-1 Decision Tables of the Lateral Force Code

A.1 General requirement

1	(T1D1) Designed and constructed to resist stresses produced by lateral forces	Y	Else Y Y N		
2	(T11) Consideration of lateral load direction and position acceptable	Y	Y	N	I
3	(BWELD) Designed considering wind load and earthquake load, whichever is larger	Y	N	I	I
1	(T10) Lateral force requirement acceptable	X			
2	Lateral force requirement not acceptable		X	X	X

A.2 Consideration of load direction and position

1	(BEDIEL) Consideration of the force applied horizontally at each floor	Y	Y	Y	N
2	(BEDIRL) Consideration of the force applied horizontally at roof level above the base	Y	Y	N	I
3	(BEANYN) Consideration of the force coming from any horizontal direction	Y	N	I	I
1	(T11) Consideration of load direction and position acceptable	X			
2	Consideration of load direction and position not acceptable		X	X	X

Table 1-1 (continued)

D. Minimum earthquake forces for structures

1	(BELEM)	Lateral force on element of structures considered	Y	N	Y	Y	N
2	(T111)	Alternate determination and distribution of seismic forces considered	I	Y	N	Y	N
3	(BWSTR)	Minimum earthquake forces for structures considered	Y	I	N	N	I
1	(T1D1)	Structure designed and constructed, acceptable	X	X			
2		Structure designed and constructed, not acceptable			X	X	X

I. Alternate determination and distribution of seismic forces

1	(BDYNAD)	Substantiated technical data by dynamic analysis available	Y			N
1	(T111)	Alternate determination and distribution of seismic forces acceptable	X			
2		Alternate determination and distribution of seismic forces not acceptable				X

Table 1-2 Revision of a Provision by Decision Table³⁾

1(D). Minimum Earthquake Forces for Structures

Except as provided in Section 1(G) and 1(I), every structure shall be designed and constructed to resist minimum total lateral seismic forces assumed to act nonconcurrently in the direction of each of the main axes of the structure in accordance with the formula: $V = ZIKCSW$

(a) original provision

		Engineering decision								
		1	2	3	4	5	6	7	8	
1.	Lateral force on element of structures considered	1(G)	Y	Y	Y	Y	N	N	N	N
2.	Alternate determination and distribution of seismic forces considered	1(I)	N	Y	N	Y	Y	Y	N	N
3.	Min. earthquake forces for structures considered	1(D)	Y	Y	N	N	N	Y	Y	N
	Structure designed and constructed, acceptable	T1D1	x	x			x	x		
	Structure designed and constructed, not acceptable				x	x			x	x

(b) decision table for criterion as a whole

		revised rule					
		1	5	3	4	7	
		2	6			8	
1.	Lateral force on element of structures considered	1(G)	Y	N	Y	Y	N
2.	Alternate determination and distribution of seismic forces considered	1(I)	I	Y	N	Y	N
3.	Min. earthquake forces for structures considered	1(D)	Y	I	N	N	I
	Structure designed and constructed, acceptable	T1D1	x	x			
	Structure designed and constructed, not acceptable				x	x	x

(c) revised decision table

Table 1-2 (continued)

Every structure except parts or portion of structures specified in Section 1(G) shall be designed and constructed to resist minimum total lateral seismic forces assumed to act nonconcurrently in the direction of each of the main axes of the structure in accordance with the formula $V = ZIKCSW$.
An alternate method is available according to Section 1(I).

(d) revised provision

Table 1-3 Network Problems in Civil Engineering

System	Significance of Branches	Significance of Nodes
Framed structures	Structural members	Joints
Hydraulic systems	Pipes or Conduits	Junctions
Surveying systems	Traverses	Bench marks
Transportation systems	Transportation links	Loads ports
Construction schedule	Activities	Events

Table 1-4 Comparison of Arguments of ACI and AISC

Arguments	ACI (Part 4, Part 5)	AISC* 4),11)
Facility	<u>Components</u> Slab Walls Footings Flexural Members Prestressed Concrete Shell and Plate Members Connector Connections <u>Property</u> Dimension Material	<u>Components</u> <u>Members</u> Thin-wall, Solid shapes Encased comp., Non-Enc. Comp. <u>Elements of Members</u> Brg. Stiffeners BM/GRDR WEB <u>Connections</u> Connector Bolts Groove Weld Fillet Weld Bearing Surface Rivets Plug/Slot Wld. Shear Connector Pins Roller/ Rocker
Environments	Atmosphere	
Interaction	<u>Limit States</u> Yielding Instability <u>Philosophy</u> Elastic Design Limit Design	<u>Limit States</u> Yielding Instability Global Local
Performance	<u>Stress States</u> Axial force Flexural force Shearing force Torsional force Bearing Combined forces <u>Safety</u> <u>Serviceability</u> displacement cracks finish	<u>Stress States</u> Axial force Tension Compression Flexural force Shearing force Torsional force Bearing Combined forces Comp. + Bending Tension + Bending Shear + Bending

Table 1-5 An Example of the AISC Organization¹⁾

COMPONENTS		LIMIT STATES		STRESS STATES	
1. MEMBERS					
1.1 THIN-WALL SHAPE					
1.1.1 YIELDING					
1.1.1.1 AXIAL FORCE					
1.1.1.1.1		TENSION	1.5.1.1.A		
1.1.1.1.2		COMPRESSION	1.5.1.3.A	2.3.A	
1.1.1.2		FLEXURAL FORCE	1.5.1.4.A		
1.1.1.3		SHEARING FORCE	1.5.1.2.A		
1.1.1.4 COMBINED FORCES					
1.1.1.4.1		COMPR+BENDING	1.6.1.A	1.6.1.B	
1.1.1.4.2		TENSION+BENDING	1.6.2.A		
1.1.2 INSTABILITY					
1.1.2.1 GLOBAL					
1.1.2.1.1		AXIAL FORCE			
		COMPRESSION	1.5.1.3.A	2.4.A	2.3.A
1.1.2.1.2		FLEXURAL FORCE	1.5.1.4.A	2.9.A	
1.1.2.1.3		COMBINED FORCES			
		COMPR+BENDING	1.6.1.A	1.6.1.B	2.4.A
1.1.2.2 LOCAL					
1.1.2.2.1		AXIAL FORCE			
		COMPRESSION	1.5.1.3.A	2.4.A	
1.1.2.2.2		FLEXURAL FORCE	1.5.1.4.A		
1.1.2.2.3		COMBINED FORCES			
		COMPR+BENDING	1.6.1.A	1.6.1.B	2.4.A
1.1.2.2.3.1		COMPR+BENDING	1.6.1.A	1.6.1.B	2.4.A
1.1.2.2.3.2		TENSION+BENDING	1.6.2.A		

(a) Components, Limit States, Stress States

COMPONENTS		STRESS STATES		LIMIT STATES	
1. MEMBERS					
1.1 THIN-WALL SHAPE					
1.1.1 AXIAL FORCE					
1.1.1.1		TENSION	1.5.1.1.A		
		YIELDING			
1.1.1.2		COMPRESSION	1.5.1.3.A	2.3.A	
1.1.1.2.1		YIELDING	1.5.1.3.A	2.4.A	2.3.A
1.1.1.2.2		INSTABILITY	1.5.1.3.A	2.4.A	
		GLOBAL			
		LOCAL			
1.1.2 FLEXURAL FORCE					
1.1.2.1		YIELDING	1.5.1.4.A		
1.1.2.2 INSTABILITY					
1.1.2.2.1		GLOBAL	1.5.1.4.A	2.9.A	
1.1.2.2.2		LOCAL	1.5.1.4.A		
1.1.3 SHEARING FORCE					
1.1.3.1		YIELDING	1.5.1.2.A		
1.1.4 COMBINED FORCES					
1.1.4.1		COMPR+BENDING			
1.1.4.1.1		YIELDING	1.6.1.A	1.6.1.B	
1.1.4.1.2		INSTABILITY			
		GLOBAL	1.6.1.A	1.6.1.B	2.4.A
		LOCAL	1.6.1.A	1.6.1.B	2.4.A
1.1.4.2		TENSION+BENDING			
1.1.4.2.1		YIELDING	1.6.2.A		
1.1.4.2.2		INSTABILITY			
		LOCAL	1.6.2.A		

(b) Components, Stress States, Limit States

COMPONENTS		STRESS STATES		LIMIT STATES	
1. MEMBERS					
1.1 THIN-WALL SHAPE					
1.1.1 AXIAL FORCE					
1.1.1.1		TENSION			PROVISION 91
		YIELDING			
1.1.1.2		COMPRESSION			PROVISION 10
1.1.1.2.1		YIELDING			PROVISION 12
1.1.1.2.2		INSTABILITY			PROVISION 13
		GLOBAL			
		LOCAL			
1.1.2 FLEXURAL FORCE					
1.1.2.1		YIELDING			PROVISION 6
1.1.2.2 INSTABILITY					
1.1.2.2.1		GLOBAL			PROVISION 4
1.1.2.2.2		LOCAL			PROVISION 5
1.1.3 SHEARING FORCE					
1.1.3.1		YIELDING			PROVISION 47
1.1.4 COMBINED FORCES					
1.1.4.1		COMPR+BENDING			
1.1.4.1.1		YIELDING			PROVISION 25
1.1.4.1.2		INSTABILITY			
		GLOBAL			PROVISION 22
		LOCAL			PROVISION 23
1.1.4.2		TENSION+BENDING			
1.1.4.2.1		YIELDING			PROVISION 26
1.1.4.2.2		INSTABILITY			
		LOCAL			PROVISION 27

(c) Revised Provisions: Components, Stress States, Limit States

Table 1-6 Formalized Procedure for Developing and Using Specifications

	Representation (Tools)	Analysis (Check of Completeness, Uniqueness, and Correctness)	Expression (Algorithm)								
Provision Level	<p>1. Decision Table</p> <table border="1"> <thead> <tr> <th>Condition Stub</th> <th>Condition Entry</th> <th>Action Stub</th> <th>Action Entry</th> </tr> </thead> <tbody> <tr> <td></td> <td></td> <td></td> <td></td> </tr> </tbody> </table> <p>2. Data (Numerical value, Boolean)</p> <p>3. Type (Limited, Extended, Mixed Entry)</p> <p>4. Polack Theorem (for Limited Entry Type) {pure rule Y, X, N, - ---- 2n rules {mixed rule I, - ---- 2Y rules</p> <p>5. Action { Satisfactory { Violated</p> <p>6. Relationship among provisions are expressed by networks.</p> <p>7. The result generated in one table can be used in conditions of other tables.</p>	Condition Stub	Condition Entry	Action Stub	Action Entry					<p>1. Syntax { Completeness } * { Redundant, Uniqueness } * { Contradictory }</p> <p>2. Semantics (Correctness) Because of the absence of explicit reference to { performance attributes } in the specifications, to { limit states Semantics check is almost impossible.</p>	<p>Decomposition Algorithm</p> <p>1. Quick Rule</p> <p>a) It performs as soon as possible.</p> <p>b) This results in the shortest program in terms of decisions.</p> <p>2. Delayed Rule</p> <p>a) It delays as long as possible.</p> <p>b) This results in reducing the average number of decisions made during execution.</p> <p>c) This also results in reducing the running time of the program.</p>
Condition Stub	Condition Entry	Action Stub	Action Entry								
Network Level	<p>1. Information networks between related provisions</p> <p>2. Hierarchy of data { Ingredient } * { Dependents } { Dependence }</p> <p>3. Tree Structure { Branch { Node</p> <p>4. Each decision table produces only one data item so that it is not necessary to distinguish nodes generated by a formula from that by a decision table.</p>	<p>1. Syntax</p> <p>a) Network must be connected; there are no data items which are not ingredients or dependents of other items.</p> <p>b) Network must be acyclic; there are no directed paths in the network.</p> <p>c) There are neither circular definitions nor iterative computations.</p> <p>2. Semantics almost impossible.</p> <p>3. A major source of incorrect interpretation arises from the textual expression of the network.</p>	<p>Execution Type</p> <p>1. Direct Execution</p> <p>a) If the nodes are ordered by the longest path from the "start" node, one obtains a sequence of execution.</p> <p>b) All cross-references pointing to the terms should be previously defined.</p> <p>2. Conditional Execution</p> <p>a) The longest path from the "end" node originates execution.</p> <p>b) The criterion to be checked is given first, then followed by its ingredient subcriteria.</p>								
Organization Level	<p>1. Topmost level describing the scope or range of applicability of a provision</p> <p>2. Entire Specification { Outline { Organize</p> <p>3. Data { Arguments { Provisions</p> <p>4. List { Arguments { Provisions</p> <p>5. A variety of hierarchies can be constructed according to ordering commands based on argument trees.</p>	<p>1. Syntax</p> <p>a) It is exhaustive to cover all possibilities.</p> <p>b) Each argument should be mutually exclusive; a given element should match only one argument.</p> <p>2. Semantics</p> <p>a) The argument tree of physical components must be complemented by a second, independent argument tree.</p> <p>b) Each of the criteria can be uniquely identified by applicable entries from the two argument trees.</p>	<p>1. General strategies have not developed yet.</p> <p>2. It is necessary to linearly sequence criteria which are indexed and only partially ordered by the nodes of disjointed attribute trees.</p>								

Table 1-7 Basic Arguments and Sub-arguments

Basic Arguments	Sub-arguments
Facility	<ul style="list-style-type: none"> 1) Classification for Entity (Serviceability) <ul style="list-style-type: none"> Physical Entity (For structural safety) <ul style="list-style-type: none"> Main Appurtenance Mechanical Entity (For human activity and health) 2) Classification for Environment (Resistance Mechanism) <ul style="list-style-type: none"> Resisting Elements Part or Portion of Structure Base Connections 3) Classification for Interaction (Geometry & Property) <ul style="list-style-type: none"> Dimension Member Properties Boundary Conditions 4) Classification for Performance (Design Details) <ul style="list-style-type: none"> Members Elements of Members Connections Connectors 5) Classification for Fabrication & Construction (Assembly) <ul style="list-style-type: none"> Location (Structural Attributes, Position in Structure) Lot (Fabrication unit, time dependent) Execution Block (Assembling Unit, a unit of transportation) Block (A set of members) Piece (An element of member)
Environment	<ul style="list-style-type: none"> 1) External Loads (Wind, Earthquake, Wave, --) 2) Atmosphere (Weather, Temperature, Humidity, Corrosion --) 3) Geography (Seismicity, ---) 4) Foundation and Substructure (Supporting Condition, B.C., --) 5) Significance 6) Internal Hazards (Fires, --)

Table 1-7 (continued)

Basic Arguments	Sub-arguments	
Interaction	1) Failure Mode (Limit State) 2) Philosophy 3) Modeling	Yielding Instability Brittle Fracture Fatigue Elastic Design Plastic Design Vibration Model (Static, Dynamic) Nonlinearity (Geometrical, Material Ductility)
Performance	1) Global Stability 2) Stress States 3) Safety 4) Serviceability	Overturning Global Buckling Aerodynamic Stability Axial Force Shearing Force Bearing Flexural Force Torsional Force Combined Force Strength Factor of Safety Allowable Stress Displacement (Drift, Deflection) Cracks Finish Vibration

Table 1-9 Revised Arguments Trees (Outline)

- 1 Components
- 2 Resisting Elements
- 3 Part of Portion of Structures
- 4 Base
- 5 Anchorage
- 6 Pile or Caissons
- 7 Framing
- 8 Connections
- 9 Property (Material)
- 10 Environment
- 11 External Loads
- 12 Seismicity
- 13 Modeling
- 14 Vibration Model
- 15 Ductility
- 16 Performance
- 17 Global Stability (Overturning)
- 18 Force
- 19 Horizontal (Latera) Force
- 20 Bending Moment
- 21 Horizontal Torsional Moment
- 22 Combined Vertical and Horizontal Forces
- 23 Serviceability
- 24 Drift
- 25 Deformation
- 26 Strength
- 27 Local Buckling

Table 1-10 Argument Trees of the 1974 BOCA (Section 618)

1	Facility
2	Main
3	Appurtenance
4	Landing Platforms
5	Handrails and Guards
6	Enclosures
7	Doors
8	Environments
9	Internal Hazards
10	Fire, Accidents
11	Theft
12	Daily Human Activity
13	Interaction
14	Safety
15	Health
16	Performance
17	Property
18	Dimension
19	Material
20	Combustible
21	Noncombustible
22	Strength
23	Physical Entity
24	Required Exit
25	Supplementary Exit
26	Others

Table 2-1 Attributes and Parameters List (1)
(Tension and Compression Criteria in the AISC)

T : Criteria (Set)
S : Subset
D : Decision table
F : Function
P : Parameter (Input)

No	Name	Attributes			Functions, Remarks	AISC Provisions
1	T1513A	T	D		Compression member check	1.5.1.3.A
2	BWTOK		D		Width-thickness ratio satisfied	1.9.a
3	BSL200	S	F		$KLOR < 200$	
4	BRACE1	S	F		$RA < 1.0$	
5	BUNST			P	Unstiffened elements	
6	BSTIF			P	Stiffened elements	
7	BUNOK		D		Unstiffened elements satisfactory	1.9.1.2.a.1
8	BSTOK	S	D		Stiffened elements satisfactory	1.9.2.2.a.1
9	KLOR		F		$K \cdot LOR$, kl/r ratio	1.5.1.3.a.6
10	LOR		F		L/R , l/r ratio	1.5.1.3.a.7
11	K		D		Effective length ratio	1.8.2.a
12	L			P	Unbraced length of compression member	
13	R			P	Least radius of gyration	
14	RA		F		$RA = FA/FFAP$, Compression stress ratio	1.5.1.3.a.4
15	FA		F		$FA = PCOMP/AGRS$, Actual Compression stress	1.5.1.3.a.1
16	FFAP		D		Modified allowable compression stress	1.5.1.3.a.3
17	PCOMP			P	P , Compression force	
18	AGRS			P	Ag , Gross area	
19	FFAP1		F		$FFAP1 = FFA / (1.6 - L/200R)$	
20	FFA		D		Fa , Allowable compression stress	1.5.1.3.a.2
21	BMAIN			P	Main member	
22	BBRACE			P	Bracing	
23	BSECM			P	Secondary member	
24	BSL120		F		$L/R > 120$	
25	BSLROC		F		$KLOR < CC$	

Table 2-1 Attributes and Parameters Lists (2)

No	Name	Attributes		Functions, Remarks	AISC Provisions
26	FFA1		F	$FFA1 = \frac{ZQS \cdot ZQA \left[1 - \frac{(KLOR)^2}{2(CC)^2} \right] FY}{\frac{5}{3} + \frac{3KLOR}{8CC} - \frac{(KLOR)^3}{8(CC)^3}}$	1.5-1
27	FFA2		F	$FFA2 = \frac{12\pi^2 E}{23(KLOR)^2}$	1.5-2
28	QS	S	D	QS as defined in Appendix C	1.9.1.2.a.2
29	QA	S	F	QA = AEFST/ACTST , in Appendix C	1.9.2.2.a.5
30	CC		F	$CC = \sqrt{\frac{2\pi^2 E}{ZQS \cdot ZQA \cdot FY}}$	1.5.1.3.a.5
31	FY		P	fy , Yield stress	
32	E		P	E , Modulus of elasticity	
33	BAPDXC		P	Use of Appendix C desired	
34	BBT238		F	WBSTST \leq 238 \sqrt{FY}	
35	BBT317		F	WBSTST \leq 317 \sqrt{FY}	
36	BBT253		F	WBSTST \leq 253 \sqrt{FY}	
37	BFLSS/ BFLRS		P	BFLSS, Flange of square sections BFLRS, Flange of rectangular sections	
38	BPCP		P	Perforated cover plate	
39	WBSTST		F	WBST/TST, (b/t) Ratio for sti. element	1.9.2.2.a.6
40	WBST		P	b, Width of stiffened elements	
41	TST		P	t, Thickness of stiffened elements	
42	AEFFST		F	(TST*WBEFF) Aeff, Effective area of stiffened elements	1.9.2.2.a.3
43	AACTST		F	(TST*WBST) Aact, Actual area of stiffened elements	1.9.2.2.a.4
44	WBEFF		D	be, Effective width of stiffened elements	1.9.2.2.a.2
45	WBCPN		P	tu, Width of unstiffened elements	
46	WBEFF2		F	WBEFF2=min[253·TST/ \sqrt{FY} (1-503/(WBST/TST) \sqrt{FY} , WBST)	
47	WBEFF3		F	WBEFF3=min[253·TST/ \sqrt{FY} (1-443/(WBST/TST) \sqrt{FY} , WBST)	
48	FSTRS		F	FSTRS = 0.6·FY·QS, in Appendix C	

Table 2-1 Attributes and Parameters Lists (3)

No	Name	Attributes			Functions, Remarks	AISC Provisions
49	VANGLE <div style="display: flex; align-items: center;"> <div style="border-left: 1px solid black; border-right: 1px solid black; border-bottom: 1px solid black; padding: 2px; margin-right: 5px;"> BSA BDAS BSTRUT BANGPG BCOL BOCM BCFB BSTPG BSTEMT </div> <div style="font-size: 2em;">}</div> </div>			P	(Mutually exclusive set)	
				P	Single angle	
				P	Double angle with separator	
				P	Strut comprising double angle in contact	
				P	Angle projecting from girders	
				P	Columns	
				P	Other compression members	
				P	Compression flanges of beams	
				P	Stiffeners on plate girders	
				P	Stem of T	
50	BBT76		F		$WBTUN \leq 76.0/\sqrt{FY}$	
51	BBT95		F		$WBTUN \leq 95.0/\sqrt{FY}$	
52	BBT127		F		$WBTUN \leq 127.0/\sqrt{FY}$	
53	BBT155		F		$WBTUN \leq 155.0/\sqrt{FY}$	
54	BBT176		F		$WBTUN \leq 176.0/\sqrt{FY}$	
55	BGCOK	S	D		Geometrical constraint satisfactory	1.9.1.2.b.1
56	QS1		F		QS1 = 1.0	
57	QS2		F		$QS2 = 1.340 - 0.0047(WBTUN)\sqrt{FY}$	
58	QS3		F		$QS3 = 15,500/FY*(WBTUN)^2$	
59	QS4		F		$QS4 = 1.415 - 0.00437(WBTUN)\sqrt{FY}$	
60	QS5		F		$QS5 = 20,000/FY(WBTUN)^2$	
61	QS6		F		$QS6 = 1.908 - 0.00715(WBTUN)\sqrt{FY}$	
62	WBTUN		F		$WBTUN = WBUN/TUN , (b/t)$	1.9.1.2.a.3
63	WBUN			P	b, Width of unstiffened element	
64	TUN			P	t, Thickness of unstiffened element	
65	BCHNNL			P	Channel section	

Table 2-1 Attributes and Parameters Lists (4)

No	Name	Attributes			Functions, Remarks	AISC Provisions
66	BBLTPT			P	Built-up T section	
67	BROLDT			P	Rolled T section	
68	BRFPD1	F			$WFODW \leq 0.25$	
69	BRFPD2	F			$WFODW \leq 0.50$	
70	BRFPD3	F			$WFODW > 0.50$	
71	BRFPS1	F			$WFODW \leq 3.0$	
72	BRFPS2	F			$WFODW \leq 2.0$	
73	BRFPS3	F			$WFODW \geq 1.25$	
74	BRFPS4	F			$WFODW \geq 1.10$	
75	WFODW	F			$WFODW = WFL/DPR, (bf/dw)$	1.9.1.2.b.2
76	TFOTW	F			$TFOTW = TFL/TWEB (tf/tw)$	1.9.1.2.b.3
77	WFL			P	bf, Width of flange	
78	DPR			P	dw, Profile depth	
79	TFL			p	tf, Thickness of flange	
80	TWEB			P	tw, Thickness of web	
81	T1511A	T			Tension member criteria	1.5.1.1.A
82	BSLROK	S	D		Slenderness ratio satisfactory	1.8.4.a
83	BRTLE1	S	F		$RT < 1.0$	
84	RT		F		$RT = FT/FFT$	
85	BMAROD			P	Rod-type member	
86	BCSLRD			P	Check for slenderness desired	
87	BMAINM			P	Main member	
88	BSL240	F			$L/R \leq 240$	
89	BSL300	F			$L/R \leq 300$	
90	FT	F			$FT = P/ANETP$, Actual tension stress	1.5.1.1.a.1

Table 2-1 Attributes and Parameters Lists (5)

No	Name	Attributes		Functions, Remarks	AISC Provisions
91	FFT		D	Ft, Allowable tension stress	1.5.1.1.a.2
92	BPINHL		P	Stress required at pin hole	
93	VBPCEY		P	(Mutually exclusive set)	
	{ BEYERR }		P	Stress required at pin hole in eye bar	
	{ BPCPLT }		P	Pin connected plate	
	{ BPCBUM }		P	Pin connected built-up member	
94	FFT1	F		FFT1 = min (0.6FY, 0.5·FTS)	
95	FFT2	F		FFT2 = 0.45 FY	
96	FTS		P	FTS, Minimum tensile strength	
97	P		P	Axial tensile force acting on it	
98	ANETP		D	An', Modified net area	1.14.a.1
99	BRED15	F		(AGRS-ANET)/AGRS \geq 0.15	
100	ANETP2	F		ANETP2 = 0.85·AGRS	
101	ANET	F		ANET = AGRS - T(NU(DIA + $\frac{1}{8}$) - REDUC)	1.14.b.2
102	AGRS		D	Ag, Gross area	1.14.b.1
103	BANGLE		P	Angle-type element	
104	AGRS1	F		AGRS1 = W·T	
105	AGRS2	F		AGRS2 = (W1 + W2 - T)T	
106	W		P	W, Width of element	
107	W1		P	W1, Width of one angle leg	
108	W2		P	W2, Width of other angle leg	
109	T		P	t, Thickness	
110	DIA		P	d, Diameter of connector	
111	NU		P	n, Number of holes	
112	REDUC	F		REDUC = SK ² /4GK	1.14.C.2
113	SK		P	Sk, Kth longitudinal pitch	

Table 2-1 Attributes and Parameters Lists (6)

No	Name	Attributes		Functions, Remarks	AISC Provisions
114	GK		D	gk, Kth gage space	1.14.C.1
115	BCOLEG		P	Considering opposite legs of angle	
116	G		P	g, Gage space between rivet holes	
117	GK2		F	$GK2 = (G1+G2-T)$, Kth gage space	
118	G1		P	Gage space from corner to hole in leg	
119	G2		P	Gage space from corner to hole in other	
120	BSSP		P	Sideway prevented	
121	BKP		P	K by rational analysis	
122	KPROV		P	K, value of K provided	
123	K1		P	$K = 1.0$	
124	K3		F	$K = \max(1.0, KPROV)$	
125	BHOLE		P	Existence of hole in tension member	
126	AREA1		P	Area of cross-section without holes	
127	BSA/BDAS		P	Single angle or double angle	
128	BSTEMT		P	Stem of T	
129	AREA2	S	D	Area of cross-section with holes	
130	BUNOK1	S	D	Unstiffened element satisfactory	
131	ZAREA2	Z	F	Total area of cross-section with holes $ZAEA2 = ZAREA2 + AREA2$	
132	ZQA			Total effective area coefficient $ZQA = \frac{ZEFFST}{ZACTST}$	
133	ZBWTOK	Z	F	$ZBWTOK = BWTOK$	
134	ZQS	Z	F	$ZQS = \min(ZQS, QS)$	
135	ZACTST	Z	F	$ZACTST = ZACTST + AACTST$	
136	ZEFFST	Z	F	$ZEFFST = ZEFFST + AEFST$	

Table 2-1 Attributes and Parameters Lists (7)

No	Name	Attributes			Functions, Remarks	AISC Provisions
137	AACTS1		F		AACTS1 = TUN * WBUN	
138	AEFFS2	S	D		Effective area of cross-section	
139	AACTS2	S	D		Actual area of cross-section	

Table 2-2 Decision Tables
(Tension and Compression Member Criteria in the AISC)

81 T1511A Tension Member Criteria

	1	2	3
1 BSLROK	*	T	T
2 BRTLE1	*	T	F

1 DESIGN SATISFACTORY	*	X	
2 DESIGN NOT SATISFACTORY	*		X

91 FFT F_t , Allowable Tension Stress

	1	2	3
1 BPINHL	*	F	T
2 BEYFRP/HPCPLT/HPCRUM	*	.	T

1 FFT=FFT1	*	X	
2 FFT=FFT2	*		X
3 ELSE RULE	*		X

1 T1513A Compression Member Criteria

	1	2	3
1 BWTOK	*	T	T
2 BSL200	*	T	F
3 BRALE1	*	T	.

1 DESIGN SATISFACTORY	*	X	
2 DESIGN NOT SATISFACTORY	*		X

20 FFA F_a , Allowable Compression Stress

	1	2
1 BSLRUC	*	T

1 FFA=FFA1	*	X
2 FFA=FFA2	*	X

Table 2-3 Decision Tables
(Tension and Compression Member Criteria in the AISC)

11 K Effective Length Ratio for Comp. Member

		1	2	3	4	5
1 BMAINM	*	T	T	T	F	F
2 BBRAE/BSECM	*	F	F	F	T	T
3 BSSP	*	T	T	F	.	.
4 BKP	*	T	F	T	.	T
5 BSL120	*	.	.	.	T	F

1 K=K1	*		X		X	
2 K=KPROV	*	X				X
3 K=K3	*			X		

82 BSLROK Slenderness Ratio Satisfactory

		1	2	3	4	5	6
1 BMAROD	*	T	F	F	F	F	F
2 BCSLRD	*	.	F	T	T	T	T
3 BMAINM	*	.	.	T	F	T	F
4 BSL240	*	.	.	T	.	F	.
5 BSL300	*	.	.	.	T	.	F

1 BSLROK=YES	*	X	X	X	X		
2 BSLROK=NO	*					X	X

2 BWTOK Width-thickness Ratio Satisfactory

		1	2	3	4	5	6	7
1 BUNST	*	T	T	F	F	T	T	T
2 BSTIF	*	F	F	T	T	T	T	T
3 BUNOK	*	T	F	.	.	T	T	F
4 BSTOK	*	.	.	T	F	T	F	.

1 BWTOK=YES	*	X		X		X		
2 BWTOK=NO	*		X		X		X	X

130 BUNOK1 Unstiffened Element Satisfactory

		1	2	3	4	5	6	7	8	9	10	11
1 BSA/BUAS	*	T	T	F	F	F	F	F	F	F	F	F
2 VANGLE	*	F	F	T	T	F	F	F	T	T	F	F
3 BSTEMT	*	F	F	F	F	T	T	F	F	F	T	T
4 BBT76	*	T	F	F
5 BBT95	*	.	.	T	F	.	.	.	F	F	.	.
6 BBT127	*	T	F	.	.	.	F	F
7 BAPDXC	*	.	.	.	T	.	T	F	F	T	F	T
8 HGCOK	*	.	.	.	T	.	T	.	.	F	.	F

1 BUNOK1=YES	*	X	X	X	X	X	X					
2 BUNOK1=NO	*							X	X	X	X	X

Table 2-4 Decision Tables
(Tension and Compression Member Criteria in the AISC)

28 QS Reduction Factor of Compression Member		1	2	3	4	5	6	7	8	9
1 BSA/BDAS	*	T	T	T	F	F	F	F	F	F
2 VANGLE	*	F	F	F	T	T	T	F	F	F
3 BSTEMT	*	F	F	F	F	F	F	T	T	T
4 BBT76	*	T	F	F
5 BBT95	*	.	.	.	T	F	F	.	.	.
6 BBT127	*	T	F	F
7 BAPDXC	*	.	T	T	.	T	T	.	T	T
8 BBT155	*	.	T	F
9 BBT176	*	T	F	.	T	F
10 BGCUK	*	.	.	.	T	T	T	T	T	T

1 QS=QS1	*	X			X			X		
2 QS=QS2	*		X							
3 QS=QS3	*			X						
4 QS=QS4	*					X				
5 QS=QS5	*						X			X
6 QS=QS6	*								X	
8 BSTOK Stiffened Elements Satisfactory										
		1	2	3	4	5	6	7	8	
1 BFLSS/bFLRS	*	T	T	F	F	F	T	F	F	
2 BPCP	*	F	F	T	F	F	F	T	F	
3 BBT2J8	*	T	F	.	.	.	F	.	.	
4 BBT317	*	.	.	T	.	.	.	F	.	
5 BBT253	*	.	.	.	T	F	.	.	F	
6 BAPDXC	*	.	T	.	.	T	F	.	F	

1 BSTOK=YES	*	X	X	X	X	X				
2 BSTOK=NO	*						X	X	X	
44 WBEFF be, Effective Width of Stiffened Elements										
		1	2	3	4	5				
1 BFLSS/bFLRS	*	T	T	F	F	F				
2 BPCP	*	F	F	T	F	F				
3 BBT2J8	*	T	F	.	.	.				
4 BBT317	*	.	.	T	.	.				
5 BBT253	*	.	.	.	T	F				
6 BAPDXC	*	.	T	.	.	T				

1 WBEFF=WBST	*	X			X					
2 WBEFF=WB EFF2	*		X							
3 WBEFF=WB EFF3	*					X				
4 WBEFF=WB CPN	*			X						

Table 2-5 Decision Tables
(Tension and Compression Member Criteria in the AISC)

102 AGRS		Ag, Gross Area of Elements	
1	BANGLE	*	F T

1	AGRS=AGRS1	*	X
2	AGRS=AGRS2	*	X
114 GK		g _k , k-th Gage Space	
1	BANGLE	*	F T T
2	BCULEG	*	. T F

1	GK=G	*	X X
2	GK=GK2	*	X
129 AREA2		Area of Cross-section with Holes	
1	BHOLE	*	T T F
2	BRED15	*	T F .

1	AREA2=ANET	*	X
2	AREA2=ANETP2	*	X
3	ELSE	*	X
98 ANETP		A' _n , Modified Net Area	
1	BHOLE	*	F T

1	ANETP=AREA1	*	X
2	ANETP=2*AREA2+AREA1	*	X

Table 2-6 Decision Tables
(Tension and Compression Member Criteria in the AISC)

139 AACTS2 Actual Area of Cross-section

		1	2
1 BUNST	*	T	-
2 BSTIF	*	-	T

1 AACTS2=AACTST	*	X	
2 AACTS2=AACTS1	*		X

138 AEFFS2 Effective Area of Cross-section

		1	2
1 BUNST	*	T	-
2 BSTIF	*	-	T

1 AEFFS2=AEFFST	*		X
2 AEFFS2=AACTS1	*	X	

7 BUNOK Unstiffened Elements Satisfactory

		1	2	3	4	5
1 BSTEMT	*	T	-	F	T	-
2 BCHNNL	*	-	T	F	-	T
3 BGCOK	*	T	T	.	F	T
4 BUNOK1	*	T	T	T	.	F

1 BUNOK=YES	*	X	X	X		
2 BUNOK=NO	*				X	X

BCHNNL	Y	Y	Y	Y	Y	N	N	N	N	N	N	N	N	N	N	E
BBLTPT	N	N	N	N	N	N	Y	Y	Y	Y	N	N	N	N	N	
BROLDT	N	N	N	N	N	N	N	N	N	Y	Y	Y	Y	Y	N	
BRFPD1	Y	Y	N	N	N											
BRFPD2	I	I	Y	Y	N											
BRFPD3	I	I	I	I	I	Y	Y	N	N	Y	Y	N	N			
BRFPS1	Y	N	I	I												
BRFPS2			Y	N												
BRFPS3						Y	N	Y	N							
BRFPS4										Y	N	Y	N			
<hr/>																
BGCOK = YES	Y		Y		Y					Y						Y
BGCOK = NO		Y		Y	Y		Y	Y	Y		Y	Y	Y			
Else Rule																Y

55 BGCOK Geometrical Constraint Satisfactory

Table 2-7 Decision Table
(Compression Member Criteria in the AISC)

16 FFAP Modified Allowable Compression Stress

		1	2	3
1 BMAIN	*	T	F	F
2 BBRACE/BSECM	*	F	T	T
3 BSL120	*	.	T	F

1 FFAP=FFAP1	*		X	
2 FFAP=FFA	*	X		X

Table 2-8 Tension Member Check (W14x87)

A. BSLROK Parameters

B. BRTLE1 Parameters

No	Name	CASE1	CASE2	No	Name	CASE1	CASE2
12	R	3.70	"	31	FY	36	"
13	L	324.	458.	96	FTS	58	"
87	BMAINM	Y	"	92	BPINHL	N	"
86	BCSLRD	Y	"	93	VBPCEY	{N}	"
85	BMAROD	N	"	92	P	+891	+446
				125	BHOLE	N	"
				126	AREA1	25.6	"

C. Results of BSLROK (Slenderness Ratio)

88	BSL240	L/R < 240	Y	Y
89	BSL300	L/R < 300	Y	Y
82	BSLROK	(D. Table rule 3)	Y	Y

D. Results of BRTLE1 (Tension Stress Ratio)

95	FFT2	0.45FY	16.2	"
94	FFT1	min (0.6FY, 0.5FTS)	21.6	"
98	ANETP	(D. Table rule 1) ANETP = AREA1	25.6	"
90	FT	P/ANETP	34.8	17.4
91	FFT	(D. Table rule 1) FFT = FFT1	21.6	21.6
84	RT	FT/FTT	1.66	0.805
83	BRTLE1	RT < 1.0	N	Y

E. Result of Tension Check

81	T1511A	(D. Table rule 1)	N	Y
----	--------	-------------------	---	---

Table 2-9 Parameters for each subset of compression check (W14x87)

No	Name	Data	No	Name	Data	No	Name	Data	
BGCOK (Geometric requirement)									
65	BCHNNL	[N]*4	12	L	324	5	BUNST	[Y]*4	
66	BBLTPT	[N]	13	R	3.70	6	BSTIF	[N]	
67	BROLDT	[N]	22	BBRACE	N	31	FY	[36]	
77	WFL	-	23	BSECM	N	33	BAPDXC	[Y]	
78	DPR	-	120	BSSP	N	37	BFLSSB	[N]	
79	TFL	-	121	BKP	N	38	BPCP	[N]	
80	TWEB	-	122	KPROV	-	40	WBST	-	
BSTOK (Stiffened elements)									
33	BAPDXC	Y	123	K1	1.0	41	TST	-	
31	FY	36							0.420
37	BFLSSB	N							[7.25]
38	BPCP	N							[0.688]
40	WBST	12.62							-
41	TST	0.420							-
BUNOK1 (Ratio of width to thickness)									
31	FY	[36]*4	31	FY	[36]*4	5	BUNST	[Y]*4	
33	BAPDXC	[Y]	33	BAPDXC	[Y]	6	BSTIF	[N]	
49	VANGLE	[{Y}]	49	VANGLE	[{Y}]	40	WBST	-	
63	WBUN	[7.25]	63	WBUN	[7.25]	41	TST	-	
64	TUN	[0.688]	64	TUN	[0.688]	63	WBUN	[7.25]	
127	BSABDA	[N]	127	BSABDA	[N]	64	TUN	[0.688]	
128	BSTEMT	[N]	128	BSTEMT	[N]				
AACTS2 (Actual area)									
BSL200 (Slenderness ratio)									
AEFFS2 (Effective area)									
AACTK1 (Ratio of width to thickness)									
AACTK2 (Actual area)									

*4 : 4 cyclings for all parameters

Table 2-10 Compression Member Check (W14x87)

BRACE1 Parameters

No	Name	CASE1	CASE2	No	Name	CASE1	CASE2
11	K	1.0	"	21	BMAIN	Y	"
12	L	324.0	(458.)	22	BBRACE	N	"
13	R	3.70	"	23	BSECM	N	"
17	PCOMP	-171.0	(-291.)	31	FY	36	"
18	AGRS	25.6	"	32	E	30,000	"

Results of Subsets

55	BGCOK	Else	140	AACTS2	(4.99,4.99,4.99,4.99,5.3)
8	BSTOK	Y	139	AEFFS2	(4.99,4.99,4.99,4.99,5.3)
130	BUNOK1	(Y, Y)	135	ZACTST	25.3
3	BSL200	Y	136	ZEFFST	25.3
28	QS	(1.0, 1.0)	132	ZQA	1.0
134	ZQS	1.0	133	ZBWTOK	Y

BRACE1 Procedures and BRACE1 and T1513A Results

			CASE1	CASE2
9	KLOR	K·L/R	87.56	123.8
24	BSL120	L/R > 120	N	Y
15	FA	PCOMP/AGRS	6.68	11.36
30	CC	$\left(\frac{2\pi^2 E}{ZQA \cdot ZQS \cdot FY}\right)^{1/2}$	128.	"
26	FFA1	$\frac{ZQS \cdot ZQA \left[1 - \frac{1}{2} \left(\frac{KLOR}{CC}\right)^2\right] FY}{\frac{5}{3} + \frac{3}{8} \frac{KLOR}{CC} - \frac{1}{8} \left(\frac{KLOR}{CC}\right)^3}$	14.05	10.00
27	FFA2	$12\pi^2 E / (23 \cdot (KLOR)^2)$	20.15	10.08
25	BSLROC	KLOR < CC	Y	Y
20	FFA	(D. Table rule 1) FFA = FFA1	14.05	10.00
19	FFAP1	FFA / (1.6 - L / (200R))	12.09	14.32
16	FFAP	(D. Table rule 1) FFAP = FFA	14.05	10.00
14	RA	FA / FFAP	0.475	1.136
4	BRACE1	RA < 1.0	Y	N
1	T1513A	(D. Table rule 1)	Y	N

Table 2-11 Checking Request to the Conformance Checking

1) Designation of Constraints Module
<ul style="list-style-type: none"> a) Designation of Set Network, Parameters Lists b) Specification Name
2) Structural Member
<ul style="list-style-type: none"> a) Type of Cross-Section b) Member Name c) Table Reference
3) I/O Configuration
<ul style="list-style-type: none"> a) Input, Output File b) Types of Output (Printing and computer-accessible form) c) Work File (New, Update, Save, Delete)
4) Data Mapping
<ul style="list-style-type: none"> a) Equivalence b) Global Data c) Design Data (Force, Member Length, Boundary Condition, ---) d) Member Attributes (Boolean Data, ---) e) Subscripted Data (Cycling arrangement)

Table 3-1 Software Systems for N/C throughout the World

	SYSTEM	DEVELOPER REMARKS
JAPAN (Shipyards)	HIZAC	HITACHI ZŌSEN
	KASE	KAWASAKI ZYUKO
	LOFTRAN	NIPPON KOKAN
	G-LOFT (GRAPHIC)	
	SHIP	MITSUBISHI ZYUKO
	MGF	
	APOLOS	IHI
	PDL	MITSUI ZŌSEN
	NAPS	NAMURA ZŌSEN
	VENUS	OSAKA ZŌSEN
	SHAPPS	SANOYASU
EUROPE (Shipyards)	AUTOKON	CIIR (NORWAY)
	STEER BEAR	KOCKUMS (SWEDEN)
	BRIT SHIPS	BSRA (ENGLAND)
	VIKING	VDC (SWEDEN)
USA (Aerospace)	APT (AUTOMATIC PROGRAMMED TOOLS)	MIT IITRI (ALRP in 1965)

Table 3-2 Control Statement in BRISTLAN

Capability	Control Command	Remarks
Program Definition	BSL,END	BRISTLAN Start and End
Subprogram Definition	MCST,MCED	MACRO Start and End
Identification of Figure	JOB,PNUM,MATR	JOB, Piece Number, Material
Motion & Category of Element	CONT	Continental (Counterclockwise outer edge line)
	LAND	Land (Clockwise inner edge line)
	MARK	Marking (Marking on steel plates)
	MEMO	Memorandum (Characters)
	HOLE	Drilling Holes (for positioning)
Declaration of Data	DATA,ARRY,EXTS	Data & Array Statements, External Symbols
Coordinate System	PLN1	Plane 1. Perpendicular to the earth (to global axis)
	PLN2	Plane 2. Rotated plane
	PLN3	Plane 3. Perspective Projection
Comment	CMMT	Comment (No meaning)
Declaration of Definition	NON	None, Definition of Element
Output	TURN	Turn the figures symmetrically about given axis
	SCAL	Scaling of the figures at the time of drawing
	DRFT	Designation of Drafters
	REAL,DASH	Solid line and Dashed line
	CROS	Crossing, Fabrication method of drilling holes
	DEBG	Debug, Printing of procedure
	WRIT	Writing of variables and Listng
	Definition of Special Point	STPT,ENPT
Program Algorithm	GDPT	Guide Point for Nesting Operation
	LPST,LPED	Loop Start and Loop End
Subprogram Call	GOTO,IF	GO TO, IF Statements
	CALL	MACRO Call (Definition of Figures)
	LINK	MACRO Call (Definition and link to the Motion)

Table 3-3 Percentage of fabrication and shop drawings

	Fabrication Drawings	Shop Drawings
BRIDGE	30%	70%
BUILDING	70%	30%

(Comparison of jobs)

Table 3-4 Weight of plates and sections

	Plates	Sections
BRIDGE	80%	20%
BUILDING	50%	50%

Table 3-5 N/C system in building frames

Works	Program	Capability	Data in FILE
MATERIAL HANDLING	MRG (MATERIAL REPORT GENERATOR)	<ul style="list-style-type: none"> ◦ Estimate for Order ◦ Sorting by Structural Unit and Lot ◦ Lists for Shop Operation ◦ Lists for Shop Drawings 	MRG TABLE (WIDE FLANGE, I standard Section, JIS Section & Pipe)
COORDINATES HANDLING	SDPC (SECONDARY DATA PRODUCTION COMMAND)	<ul style="list-style-type: none"> ◦ Secondary Data ◦ Shapes of Gusset Plates ◦ Cutting Size Lists for Shop Operation ◦ Checking of Structural System 	SECONDARY DATA in 3-dimensional form
SECTION HANDLING	BRISTLAN2 (BRIDGE & STEEL STRUCTURE LOFTING LANGUAGE)	<ul style="list-style-type: none"> ◦ N/C Information of a Variety of Sections ◦ Figure Processing referencing to Material Master File ◦ Figure Processing referencing to MENU Library 	MENU (Standard Patterns in rigid forms, Drilling Holes in array forms)
PLATE HANDLING	BRISTLAN(1) (BRIDGE & STEEL STRUCTURE LOFTING LANGUAGE)	<ul style="list-style-type: none"> ◦ Figure Processing for general purpose ◦ Referencing to Secondary Data ◦ Referencing to Macro Library 	MACRO (Standard Patterns in flexible forms, SLOT, MANHOLE, GUSSETS)
	BRISTLAN2	<ul style="list-style-type: none"> ◦ Figure Processing for particular patterns ◦ Referencing to MENU Library ◦ Figure Processing for Flame Cutter 	MENU (Standard Patterns with the same shapes common to Members)
POSTPROCESSING	POSTPROCESSORS A. DRAFTERS B. FLAME CUTTERS C. DRILLING	<ul style="list-style-type: none"> ◦ TSU WORKS of NKK ◦ SHIMIZU WORKS of NKK ◦ FUKUYAMA WORKS of NKK 	

Table 3-6 Block and Erection Block Lists (Output of MRG Program)

JOB NO		MATERIAL LIST (BLOCK CLASSIFICATION)		JOB MK GR		DATE 71 02 25		PAGE 1			
KIND	MATERIAL	PIECE MARK	D I M E N S I O N	I N	M M	L E N G T H	K U S U	W E I G H T	I N	K G	R M A R K
			S E C T I O N					P E R M	P E R O N E	T O T A L	
								P E R M 2			
BLOCK MARK A0											
PL	SS41	GR 1B16	16A	0.0	0.0	1978.0	2	172.70	102.50	204.96	FLG
PL	SS41	GR 1B16	16B	0.0	0.0	1978.0	1	70.65	70.71	70.71	MEB
										275.67	
										BLOCK UNIT TOTAL	
										275.67	
BLOCK MARK A1											
PL	SS41	GR LB01	SG08	0.0	0.0	790.0	4	125.60	29.77	119.07	SPL
PL	SS41	GR LB01	SG09	0.0	0.0	790.0	8	125.60	12.40	99.22	SPL
PL	SS41	GR LB01	SG11	4.5	0.0	390.0	4	35.32	1.72	6.89	FILL
PL	SS41	GR LB01	SG01	6.0	0.0	360.0	4	47.10	2.88	11.53	SPL
										236.71	
										BLOCK UNIT TOTAL	
										236.71	
MATERIAL LIST (ERECTOR BLOCK CLASSIFICATION)											
SEC NO	MATERIAL	KIND	SIZE1	SIZE2	SIZE3	SIZE4	LENGTH	KOSU	HEIGHT	DATE 71 02 24	PAGE 1
ERECTOR BLOCK 3GH2											
1	SS41	PL	12.00	300.00	0.0	0.0	5580.00	2	315.38		
2	SS41	PL	9.00	526.00	0.0	0.0	5580.00	1	207.36		
3	SS41	PL	6.00	300.00	0.0	0.0	430.00	4	24.30		
4	SS41	PL	9.00	125.00	0.0	0.0	430.00	8	30.38		
5	SS41	PL	4.50	125.00	0.0	0.0	210.00	8	7.42		
6	SS41	PL	6.00	170.00	0.0	0.0	290.00	4	9.29		
7	STK41	P	355.60	7.90	0.0	0.0	500.00	2	67.70		
										ERECTOR BLOCK UNIT TOTAL	661.83

Table 3-7 Lot, Fabrication and Shop Operation Lists
(Output of MRG Program)

LOT MANAGEMENT TABLE															DATE 71-02 25	PAGE 1
JOB NO	HOLE	HOLE SHAPE	TOTAL	CUTTING GIRTH(M)	MARKING GIRTH(M)	PLATE SHAPE	K O S U	TOTAL	W E I G H T (KG)	TOTAL	S U R F A C E PLATE	S H A P E	A R E A (M2)	TOTAL	JOB MK GR	
																LOT NO
01	0	0	0	0.0	0.0	147	0	147	4513.68	0.0	52.24	0.0	52.24	52.24		
02	0	0	0	0.0	0.0	7	180	187	120.83	199.87	0.84	9.17	10.02	10.02		
03	0	0	0	0.0	0.0	7	66	73	1029.09	605.82	21.85	25.03	46.88	46.88		
04	0	0	0	0.0	0.0	226	0	226	3444.25	0.0	39.85	0.0	39.85	39.85		
05	0	0	0	0.0	0.0	261	135	396	11094.81	196.02	74.54	7.67	82.21	82.21		
06	0	0	0	0.0	0.0	144	14	158	568.85	199.70	9.56	9.77	19.33	19.33		
07	0	0	0	0.0	0.0	168	68	236	4822.21	73.01	58.98	3.35	62.33	62.33		
08	0	0	0	0.0	0.0	3	186	189	116.38	213.86	0.78	9.81	10.59	10.59		
09	0	0	0	0.0	0.0	307	1	308	8662.48	8.90	77.01	0.26	77.27	77.27		
10	0	0	0	0.0	0.0	139	136	275	8005.25	575.12	62.37	18.29	80.66	80.66		
11	0	0	0	0.0	0.0	60	1	61	142.68	22.05	3.10	0.96	4.06	4.06		
12	0	0	0	0.0	0.0	114	0	114	29657.47	0.0	268.30	0.0	268.30	268.30		
13	0	0	0	0.0	0.0	994	67	1061	6686.13	2005.06	82.23	33.89	116.12	116.12		
14	0	0	0	0.0	0.0	105	0	105	19494.23	0.0	219.38	0.0	219.38	219.38		
15	0	0	0	0.0	0.0	901	86	987	3149.19	2911.10	54.02	48.04	102.06	102.06		
16	0	0	0	0.0	0.0	105	0	105	29154.26	0.0	202.54	0.0	202.54	202.54		
17	0	0	0	0.0	0.0	823	32	855	8148.29	657.59	82.96	12.13	95.10	95.10		
18	0	0	0	0.0	0.0	0	2	2	0.0	127.31	0.0	6.52	6.52	6.52		
19	0	0	0	0.0	0.0	16	2	18	29.11	12.78	0.51	0.59	1.10	1.10		
20	0	0	0	0.0	0.0	0	9	9	0.0	1386.41	0.0	66.84	66.84	66.84		
21	0	0	0	0.0	0.0	45	7	52	106.41	41.29	2.02	1.72	3.74	3.74		
22	0	0	0	0.0	0.0	0	9	9	0.0	1386.41	0.0	66.84	66.84	66.84		
23	0	0	0	0.0	0.0	83	6	89	134.53	36.24	2.53	1.48	4.02	4.02		
24	0	0	0	0.0	0.0	0	8	8	0.0	1368.12	0.0	65.90	65.90	65.90		
25	0	0	0	0.0	0.0	57	2	59	88.09	10.68	1.73	0.31	2.04	2.04		
31	0	0	0	0.0	0.0	0	140	140	0.0	2839.84	0.0	355.95	355.95	355.95		
32	0	0	0	0.0	0.0	0	112	112	0.0	3523.64	0.0	98.80	98.80	98.80		
33	0	0	0	0.0	0.0	234	0	234	1917.84	0.0	18.03	0.0	18.03	18.03		
34	0	0	0	0.0	0.0	0	17	17	0.0	3424.20	0.0	51.83	51.83	51.83		
35	0	0	0	0.0	0.0	0	28	28	0.0	881.11	0.0	24.73	24.73	24.73		
36	0	0	0	0.0	0.0	135	0	135	1031.46	0.0	11.67	0.0	11.67	11.67		
TOTAL	0	0	0	0.0	0.0	5101	1314	6415	142617.00	48706.13	1347.05	919.88	2266.93	2266.93		

TABLE 3-8 Comparison of BRISTLAN 1 and BRISTLAN 2

		BRISTLAN 1	BRISTLAN 2
Purpose		N/C Language for Bridges & Buildings	N/C Language for Bridges & Buildings
Capability		Plate	Plate & Section
Coordinate System		3-Dimensional ↔ 2-Dimensional	2-Dimensional
N/C Surface Control		2-Dimensional (Plane)	3-Dimensional (4 Planes in Section)
System Flow			
Category of Lines		Outer Edge (CONT) } Gas Inner Edge (LAND) } Cutting Markings (MARK) } Drawing Characters (MEMO) } Drilling (HOLE) Drilling	Outer Edge (CONT) } Gas Inner Edge (LAND) } Cutting Flame Cutter(GASS) } Marking (MARK) } Drawing Characters (MEMO) } Drilling (HOLE) Drilling
Processing Unit		Multiple Piece Processing	Multiple Piece Processing
Correlation to Material Master File		None	Keyword Reference
Processor Capability	Comparative Algorithm	Comparison of Magnitude of Scalars Region Checking Number of Intersection of Figures	None
	Branch	IF, GOTO Statement	None
	Loop	Up to Triple Nesting	None
	Registration of Program	Object Program by PASS 1	None
	Reference to FILE	SECONDARY DATA MACRO LIBRARY	MENU
	Figure List	Segment List	Segment List
Steps of Processing	PASS 1	Syntax check, Object Code	Syntax check, Object Code
	PASS 2	Linkage Edit of MACRO Library	None
	PASS 3	Figure Processing, Editing	Figure Processing, Editing
	PASS 4	Postprocessor	Postprocessor

Table 3-9 Comparison of weight and amount of pieces

	FABRICATION JOB	N/C DRAWINGS				EPM		
		Weight(kg)	Num. of Pieces	Weight(kg)/Piece	Weight(kg)	Num. of Pieces	Weight(kg)/Piece	
BRIDGE	SEISHO KOKUDO	116,176	106	1,095	135,400	774	174	
	HARASU-BASHI	98,875	145	681	100,800	306	329	
	FUJII-BASHI	50,933	250	203	73,624	309	238	
BUILDING	GINZA LEISURE CENTER BUILDING	9,371	245	38	33,136	846	39	

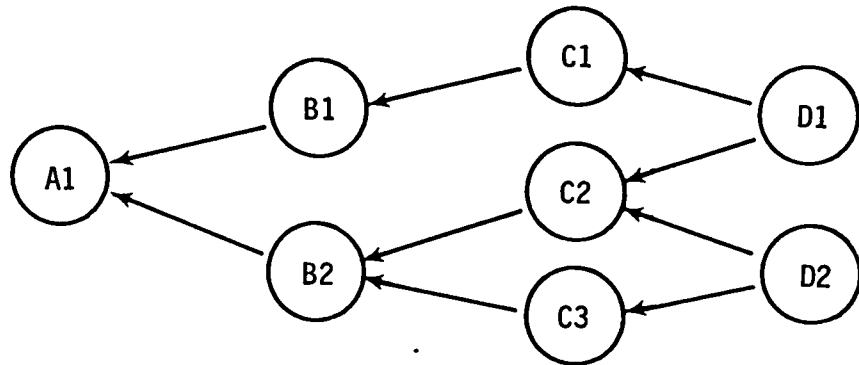

(a) General form of a network

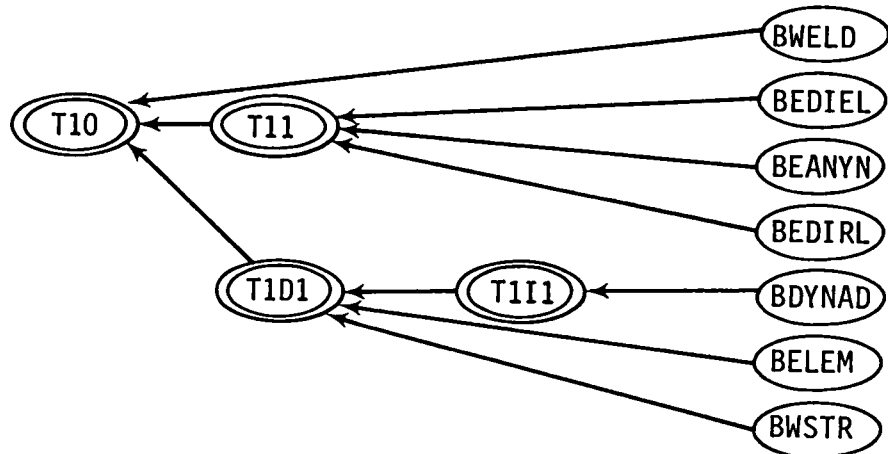

(b) Specification network (derived from Table 1-1)

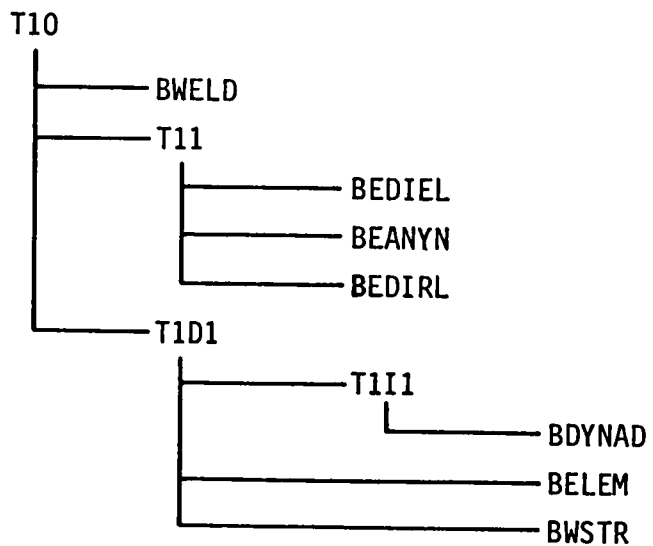

(c) A conventional expression of network

Fig. 1-2 Expression of Network

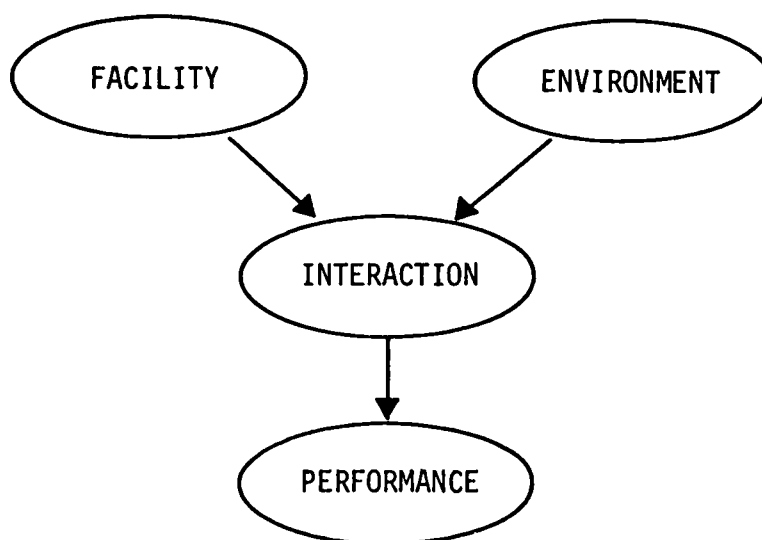

Fig. 1-3 Design Configuration

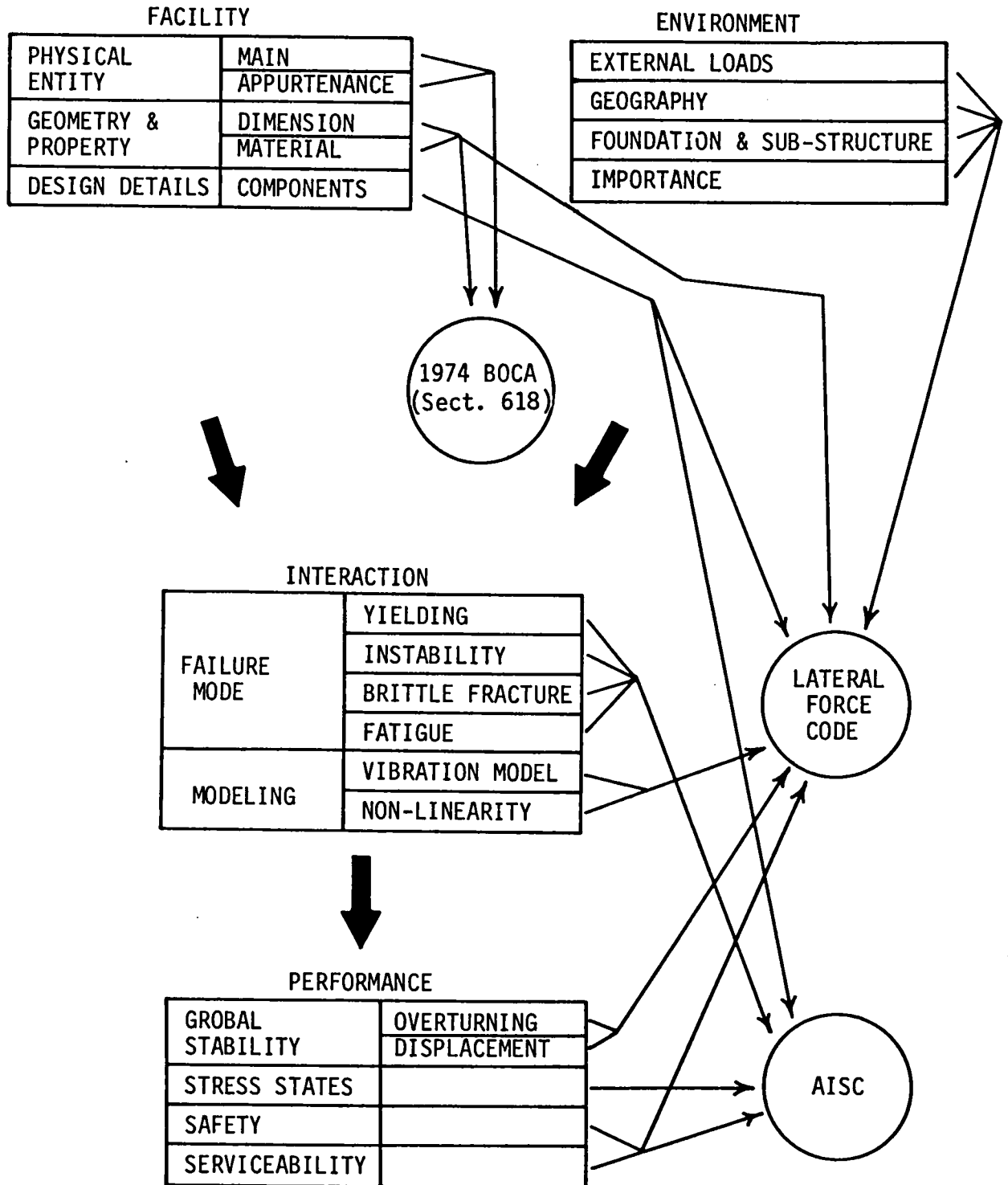

Fig. 1-4 Level of Specifications in Design Configuration

<p>FACILITY LEVEL</p>	<p>BOCA (Sect. 618)</p>	<p>↑ PLANNING</p>	<p>ASTM</p>	<p>○</p>
<p>ENVIRONMENT LEVEL</p>	<p>LATERAL FORCE REQUIREMENT</p>	<p>LOCALITY</p>	<p>○</p>	<p>○</p>
<p>INTERACTION LEVEL (ANALYSIS LEVEL)</p>	<p>○ ANALYSIS TECHNIQUE</p>	<p>PHYSICS (MATHEMATICAL MODEL)</p>	<p>○</p>	<p>○</p>
<p>PERFORMANCE LEVEL</p>	<p>AISC</p>	<p>↓ SAFETY AND SERVICEABILITY</p>	<p>ACI</p>	<p>○</p>

Fig. 1-5 Level of Specifications
(Row and Column-wise Relationship)

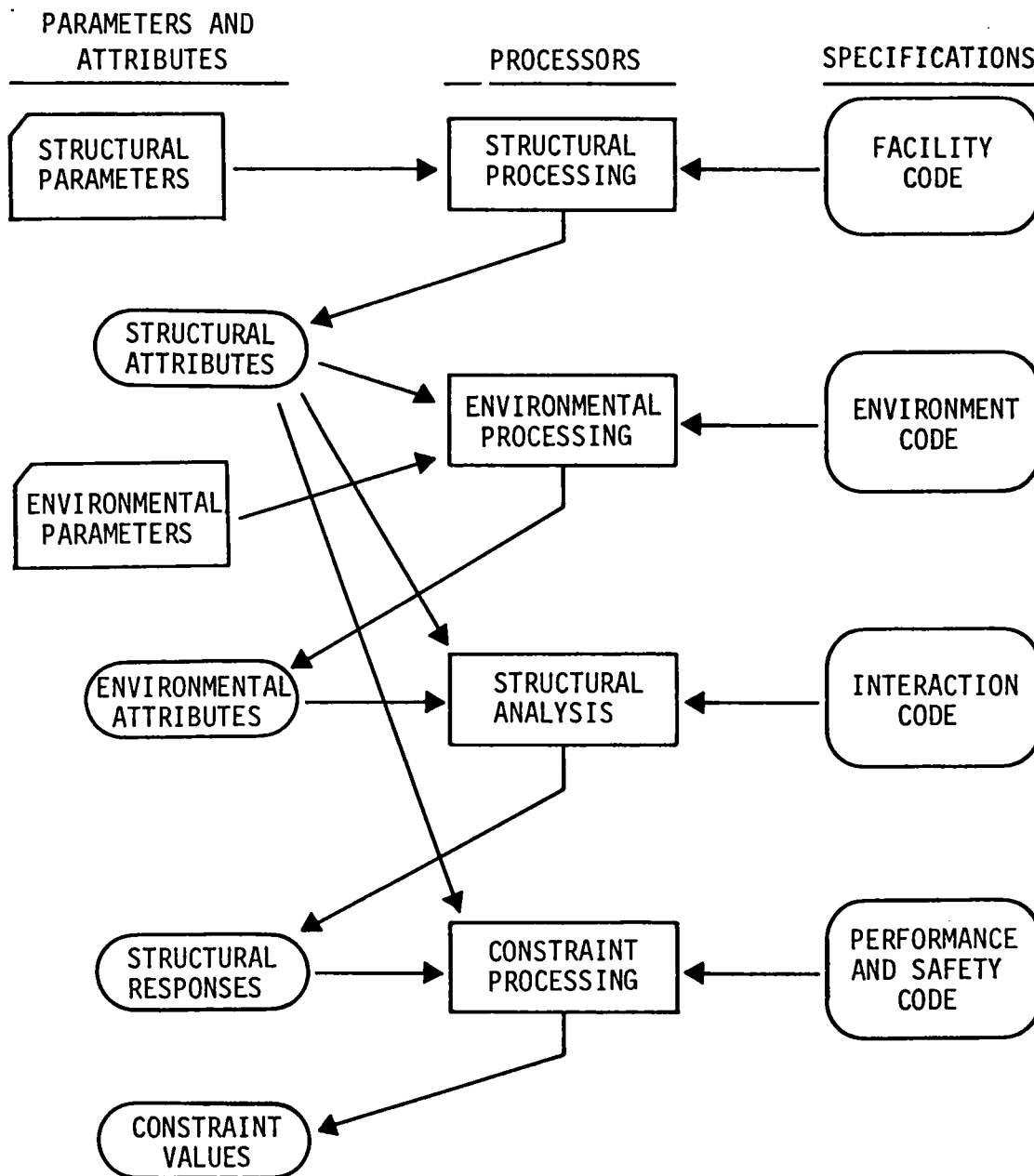
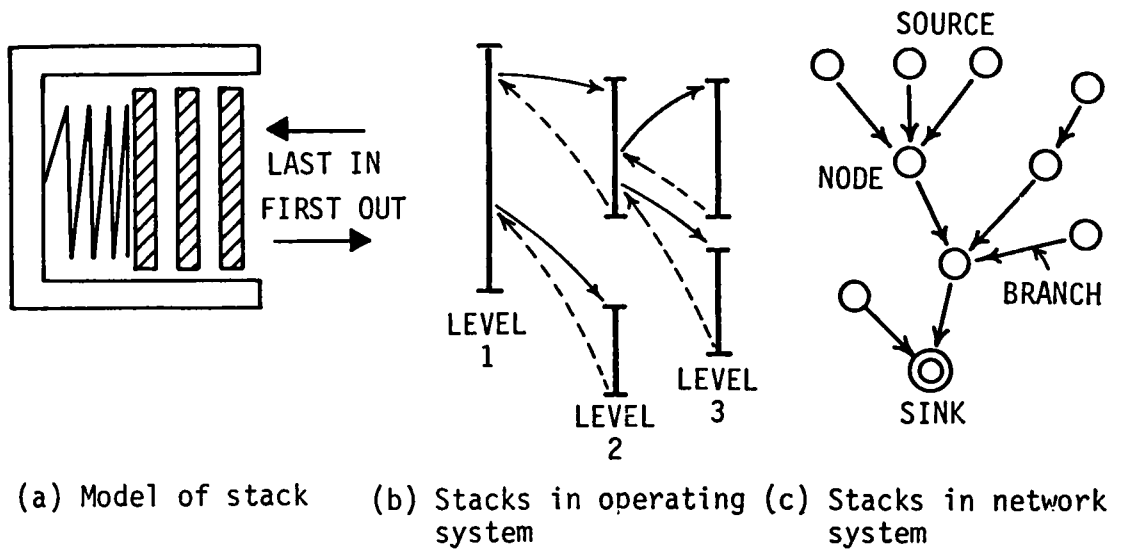

Fig. 2-1 Information Flow in Structural Design



ITEMS OF STACK ARRAY

1. Current node
2. Current pointer to ingredients or dependents
3. Pointer to outgoing branches from current node
4. Total number of ingredients and dependents

	1	2	n
1			
2			
3			
4			

(d) Stack array

Fig. 2-2 Model of Stacks

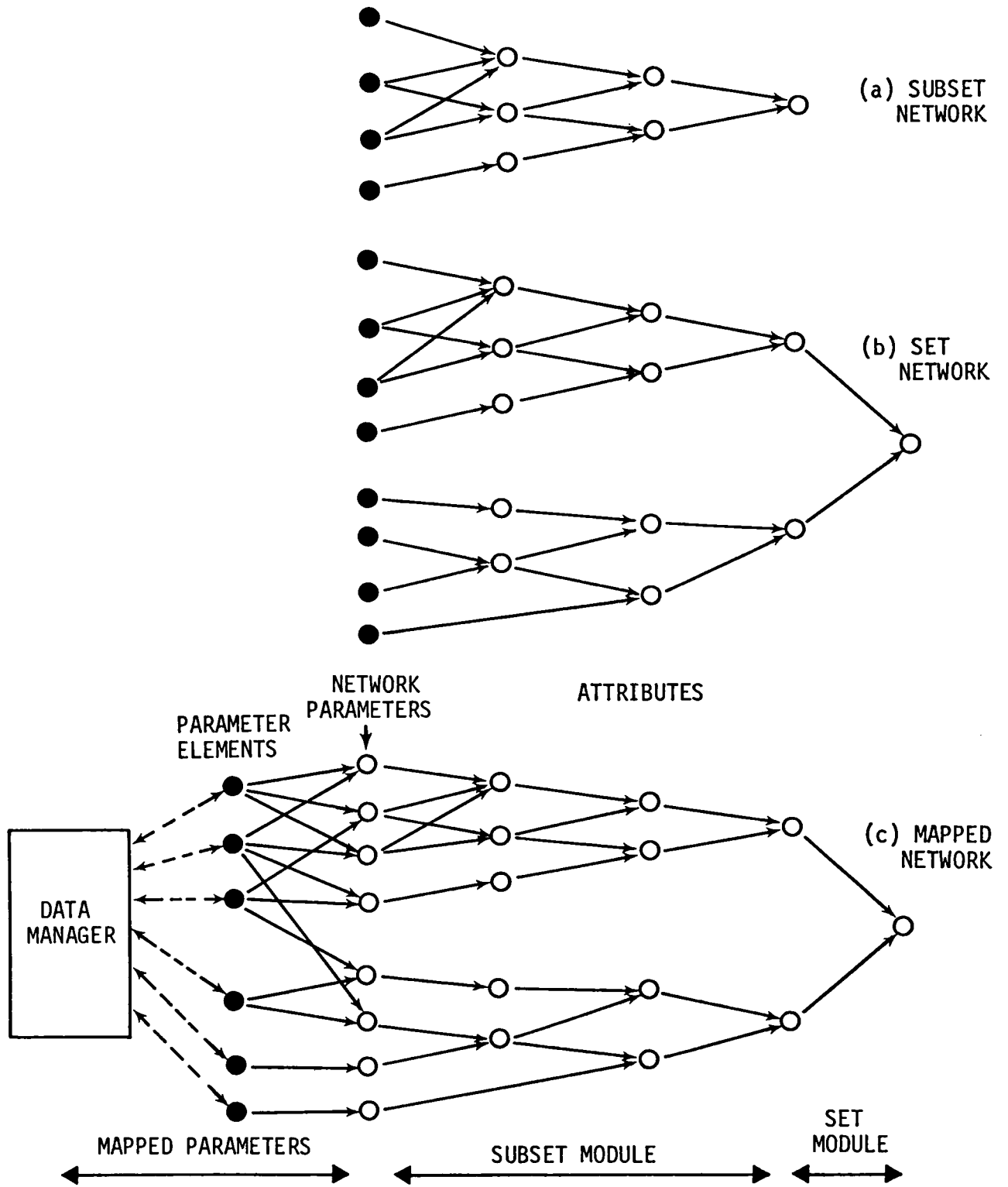
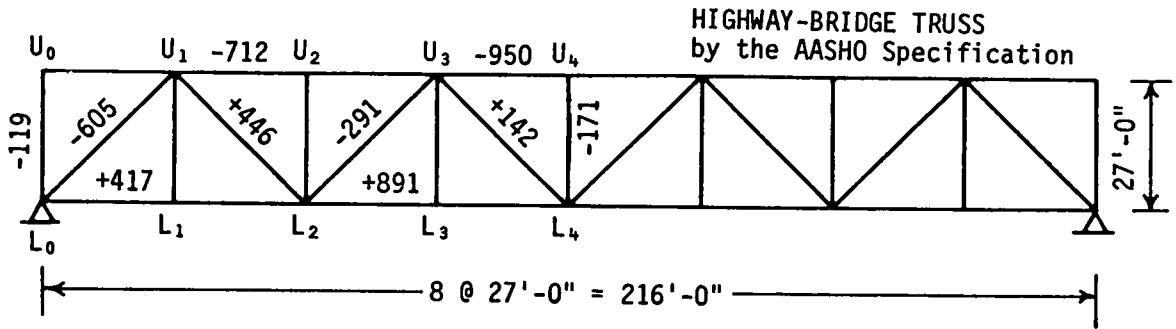
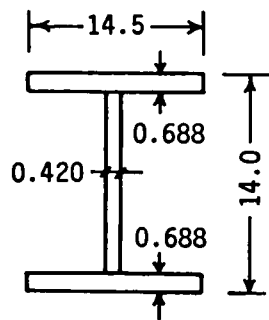

Fig. 2-3 Level of Network



Number	Member	Load (P)	Check	Section	Ag (in ²)	L (in)	γ_{min}	L/ γ_{min}
1	L ₀ L ₂	+417		W14x87	25.6	324	3.70	88
2	L ₂ L ₄	+891		W14x176	51.7	324	4.02	81
			NG	W14x87	25.6	324	3.70	88
3	U ₁ L ₂	+446	OK	W14x87	25.6	458	3.70	124
4	U ₃ L ₄	+142		W14x61	17.9	458	2.45	187
5	L ₀ U ₁	-605				458		
6	L ₂ U ₃	-291	NG	W14x87		458	3.70	124
7	L ₀ U ₀	-119				324		
8	U ₄ L ₄	-171	OK	W14x87	25.6	324	3.70	88

NG = Negative



W14x87 (A36)
 $A = 25.6 \text{ in}^2$
 $\gamma_x = 6.15 \text{ in}$
 $\gamma_y = 3.70 \text{ in}$

Fig. 2-4 Conformance Checking of Truss Members (the AISC)

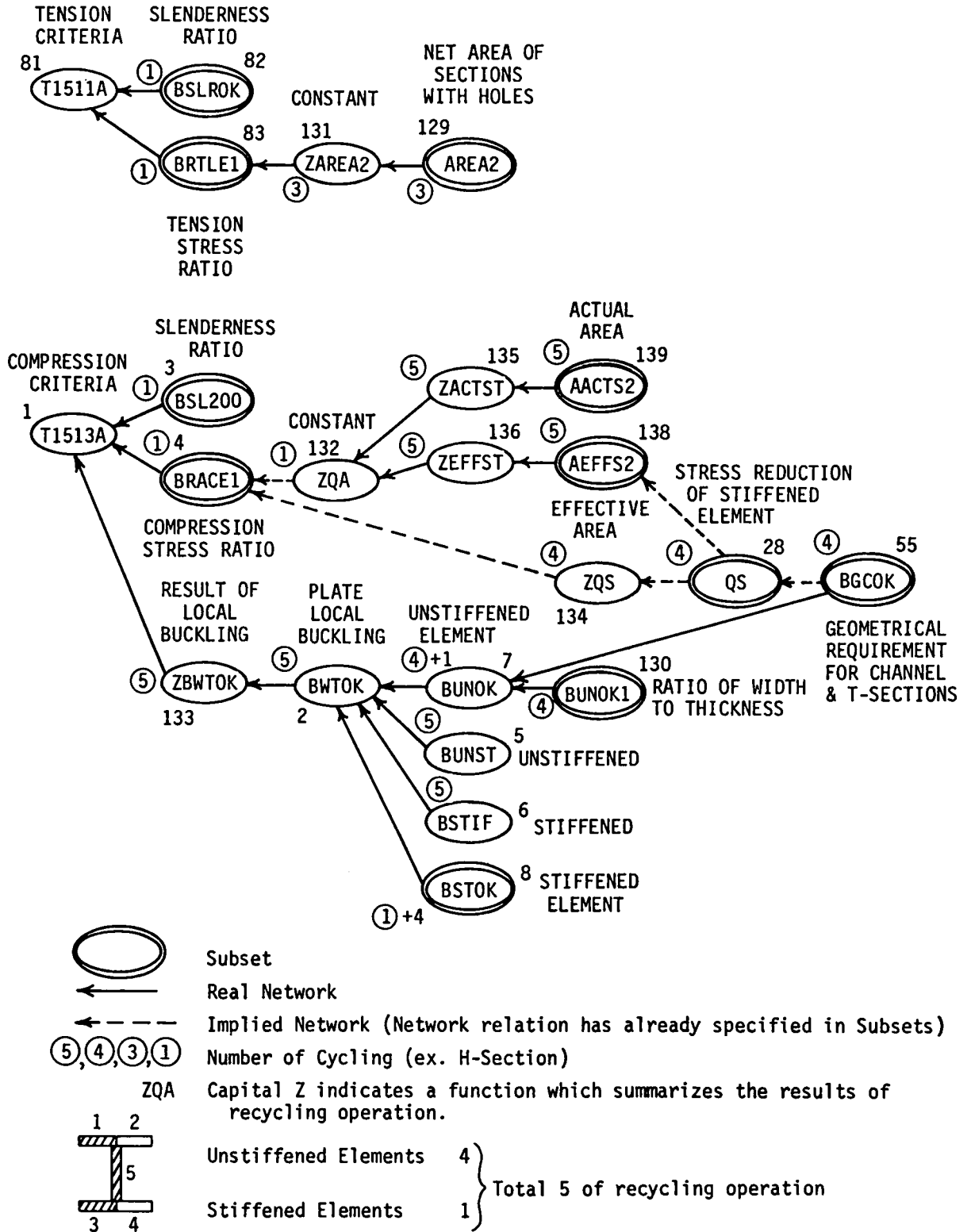

Fig. 2-5 Tension and Compression Member Criteria of the AISC

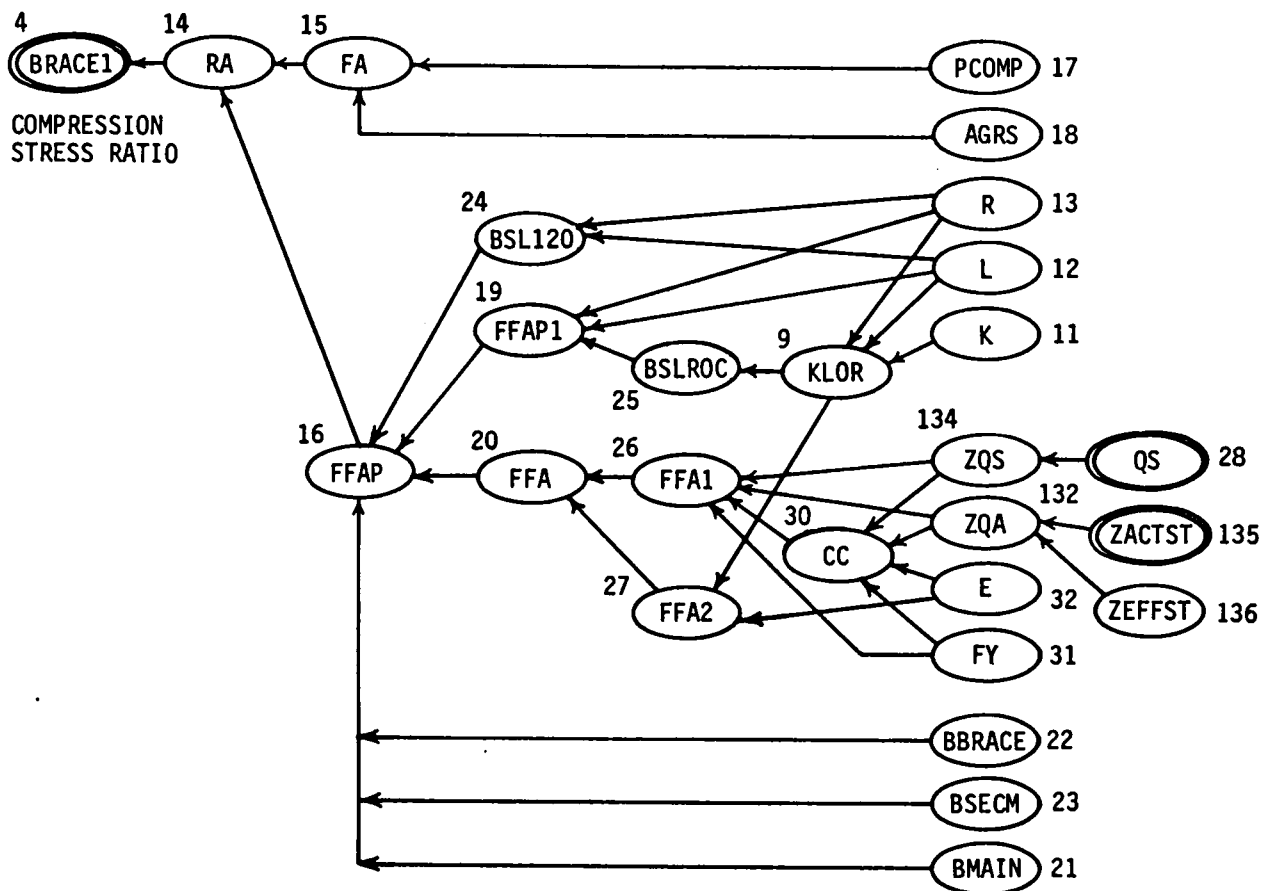
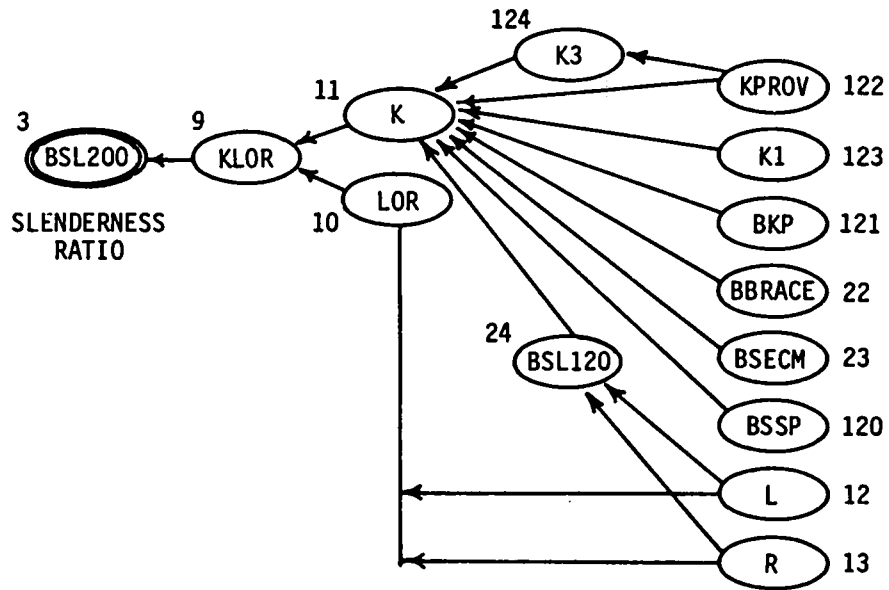

Fig. 2-6 Networks of BSL200 and BRACE1 (the AISC)

```

0           1           2           3
81 T1511A
:.....83 BRTLE1
:           :.....131 ZAREA2
:           :           :.....129 AREA2
:.....82 BSLROK

```

```

0           1           2           3
82 BSLROK
:.....89 BSL300
:           :.....10 LOR
:           :           :.....13 R
:           :           :.....12 L
:.....88 BSL240
:           :.....-10* LOR
:.....87 BMAINM
:.....86 BCSLRD
:.....85 BMAROD

```

Fig. 2-7 Networks of T1511A and BSLROK (the AISC)

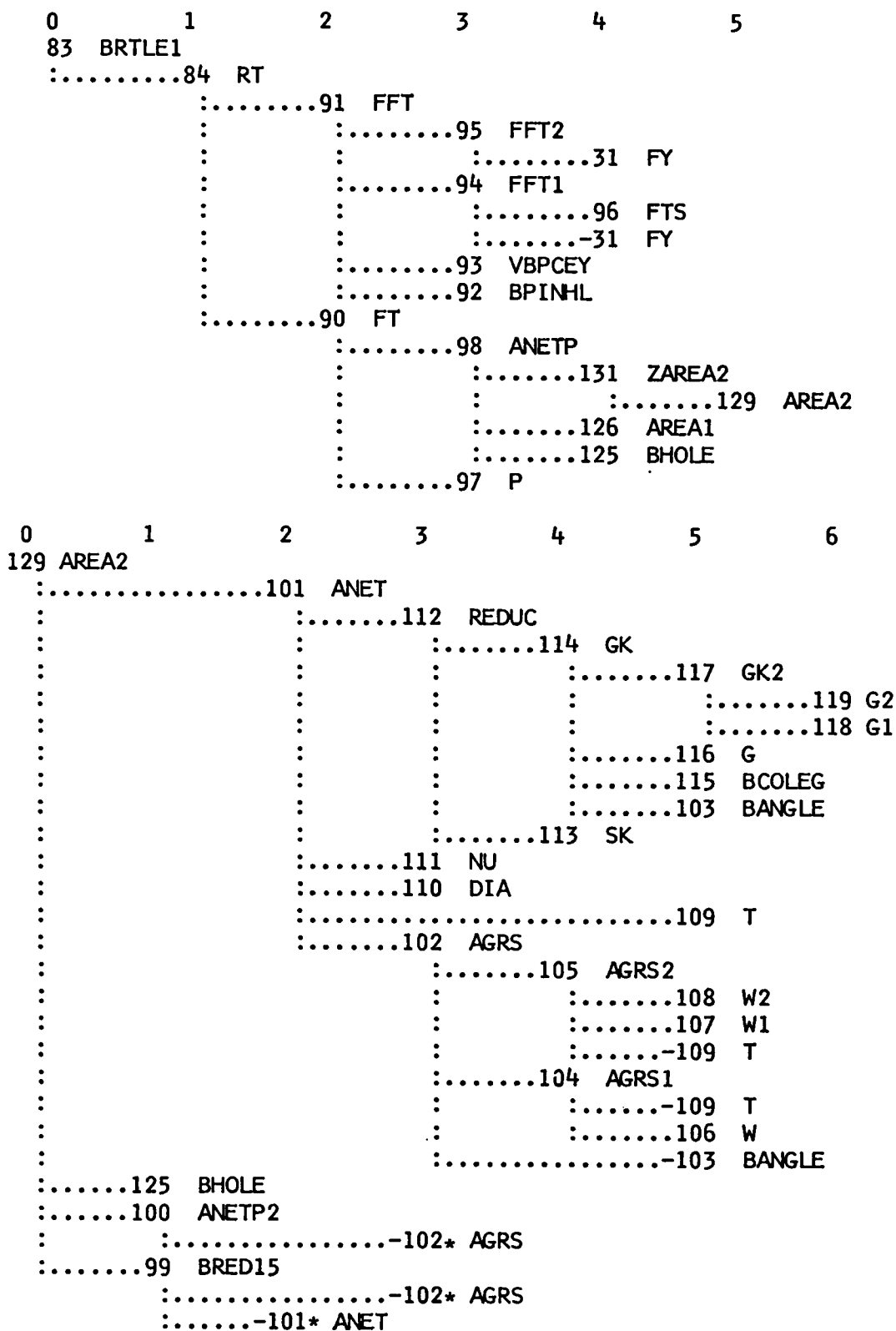

Fig. 2-8 Networks of BRTLE1 and AREA2 (the AISC)

```

0          1          2          3
130 BUNOK1
:.....33 BAPDXC
:.....127 BSABDA
:.....49 VANGLE
:.....128 BSTENT
:.....50 BBT76
:          :.....31 FY
:          :.....62 WBTUN
:          :.....63 WBUN
:          :.....64 TUN
:.....51 BBT95
:          :.....-31 FY
:          :.....-62* WBTUN
:.....52 BBT127
:          :.....-31 FY
:          :.....-62* WBTUN
:.....54 BBT176
:          :.....-62* WBTUN

```

```

0          1          2          3
55 BGCOK
:.....74 BRFPS4
:          :.....76 TFUTW
:          :.....80 TWEB
:          :.....79 TFL
:.....73 BRFPS3
:          :.....-76* TFUTW
:.....72 BRFPS2
:          :.....-76* TFUTW
:.....71 BRFPS1
:          :.....-76* TFUTW
:.....70 BRFPU3
:          :.....75 WFUDW
:          :.....78 DPR
:          :.....77 WFL
:.....69 BRFPU2
:          :.....-75* WFUDW
:.....68 BRFPU1
:          :.....-75* WFUDW
65 BCHNNL
66 BHLTPT
67 BROLDT

```

Fig. 2-9 Networks of BUNOK1 and BGCOK (the AISC)

```

0          1          2          3          4          5
138 AEFFS2
:.....137 AACTS1
:          :.....63 WBUN
:          :.....64 TUN
:.....43 AEFST
:          :.....41 TST
:          :.....44 WBEFF
:          :.....34 BBT238
:          :.....39 WBTST
:          :.....40 WBST
:          :.....41 TST
:          :.....31 FY
:.....35 BBT317
:          :.....39* WBTST
:          :.....31 FY
:.....36 BBT253
:          :.....39* WBTST
:          :.....31 FY
:.....46 WBEFF2
:          :.....48 FSTRS
:          :.....31 FY
:          :.....28 QS
:          :.....39* WBTST
:          :.....31 FY
:.....47 WBEFF3
:          :.....48* FSTRS
:          :.....39* WBTST
:          :.....31 FY
:.....33 BAPDXC
:.....37 BFLSSH
:.....38 BPCP
:.....40 WBST
:.....6 BSTIF
:.....5 BUNST

```

```

0          1          2
139 AACTS2
:.....137 AACTS1
:          :.....63 WBUN
:          :.....64 TUN
:.....42 AACTST
:          :.....40 WBST
:          :.....41 TST
:.....6 BSTIF
:.....5 BUNST

```

Fig. 2-10 Networks of AEFFS2 and AACTS2 (the AISC)

0	1	2	3
28	QS		
:127	BSARUS	
:49	VANGLE	
:128	BSTEMT	
:33	BAPDXC	
:50	BBT76	
:	31	FY
:	62	WBTUN
:		63
:		64
:51	BBT95	WBUN
:	-31	FY
:	-62*	WBTUN
:52	BBT127	TUN
:	-31	FY
:	-62*	WBTUN
:53	BBT155	
:	-31	FY
:	-62*	WBTUN
:54	BBT176	
:	-31	FY
:	-62*	WBTUN
:55	BGCDK	
:56	QS1	
:	-31	FY
:	-62*	WBTUN
:57	QS2	
:	-31	FY
:	-62*	WBTUN
:58	QS3	
:	-31	FY
:	-62*	WBTUN
:59	QS4	
:	-31	FY
:	-62*	WBTUN
:60	QS5	
:	-31	FY
:	-62*	WBTUN
:61	QS6	
:	-31	FY
:	-62*	WBTUN

Fig. 2-11 Network of QS (the AISC)

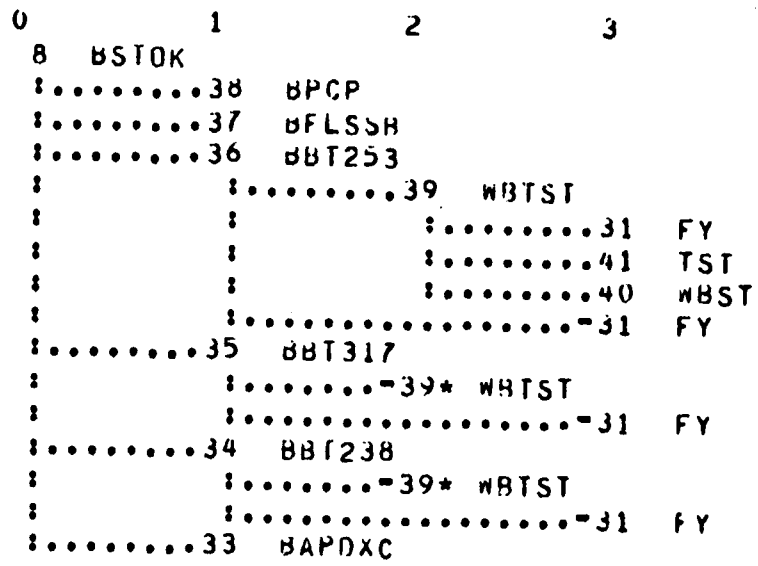

Fig. 2-12 Network of BSTOK (the AISC)

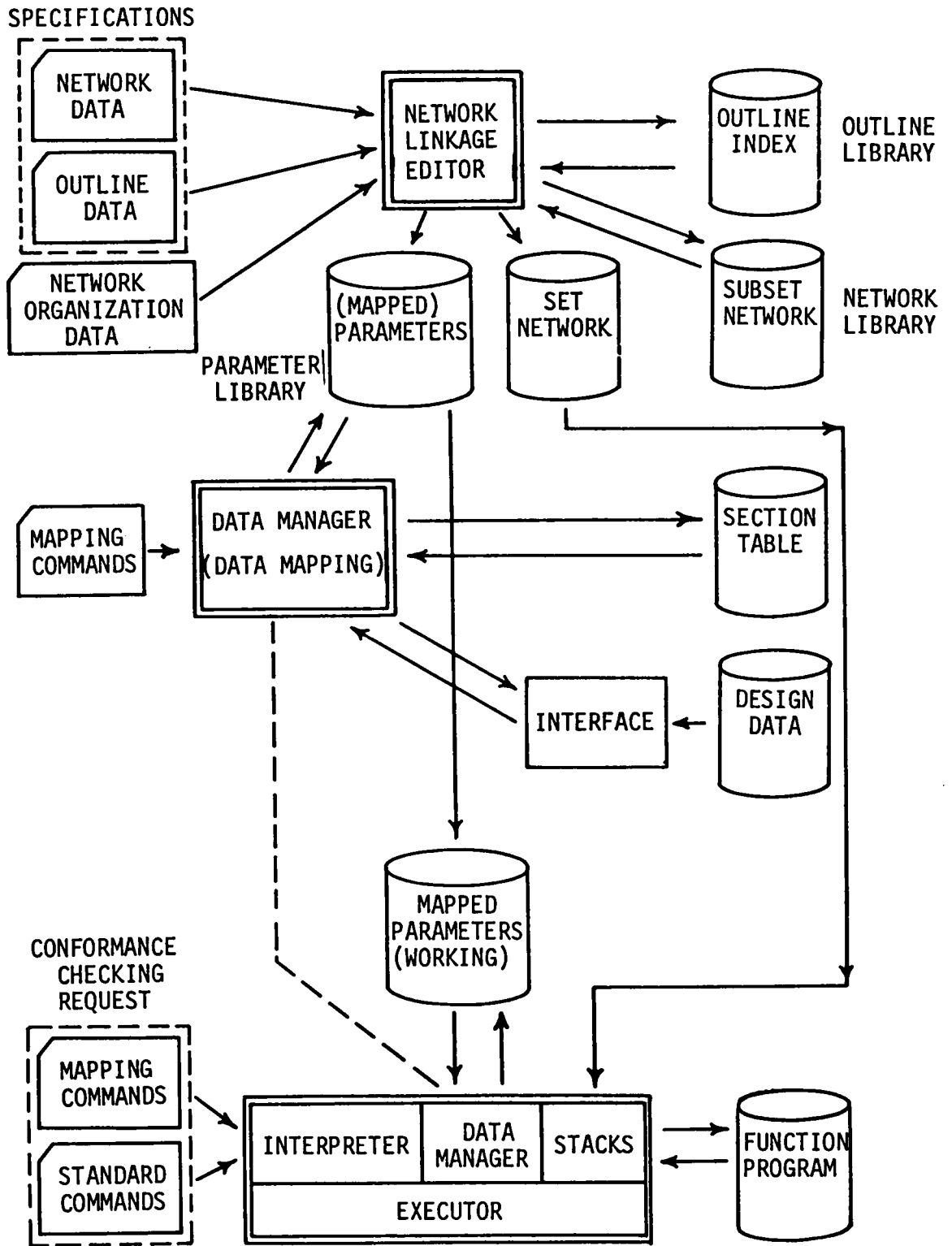

Fig. 2-14 A Model of Constraints Processing

(a) MANUAL OPERATION

(b) COMPUTER PROCESSING

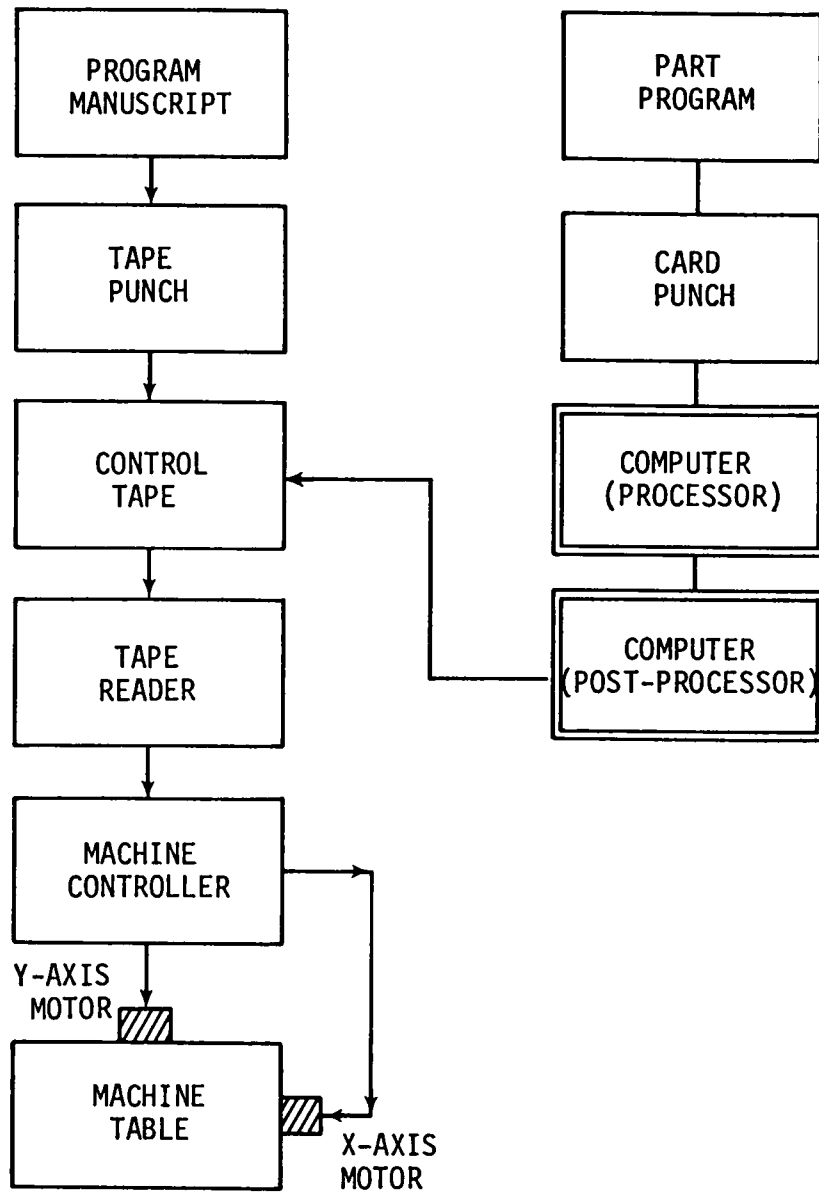

Fig. 3-1 General Procedures for Numerical Control

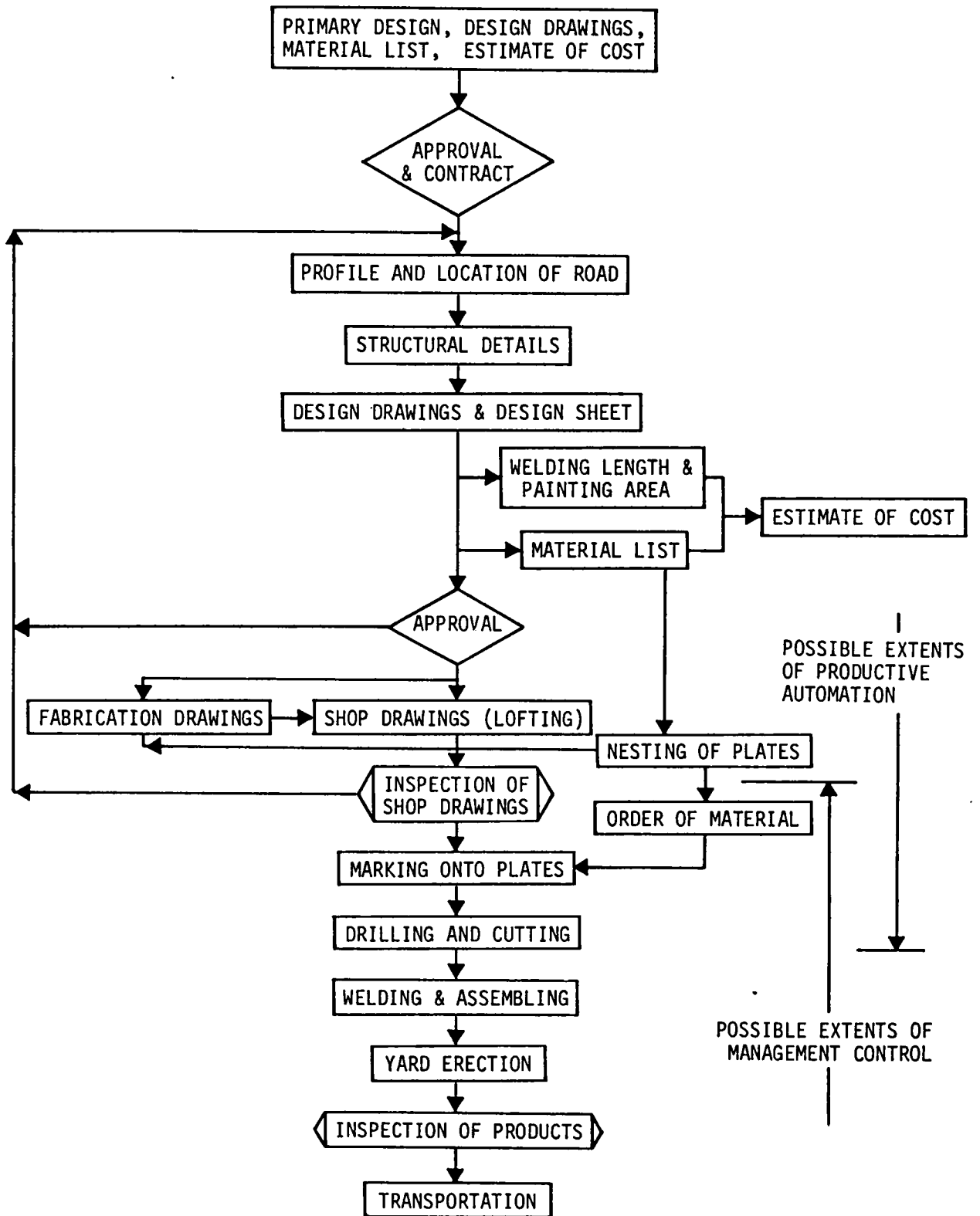

Fig. 3-2 General Flow of Bridge Design and Fabrication

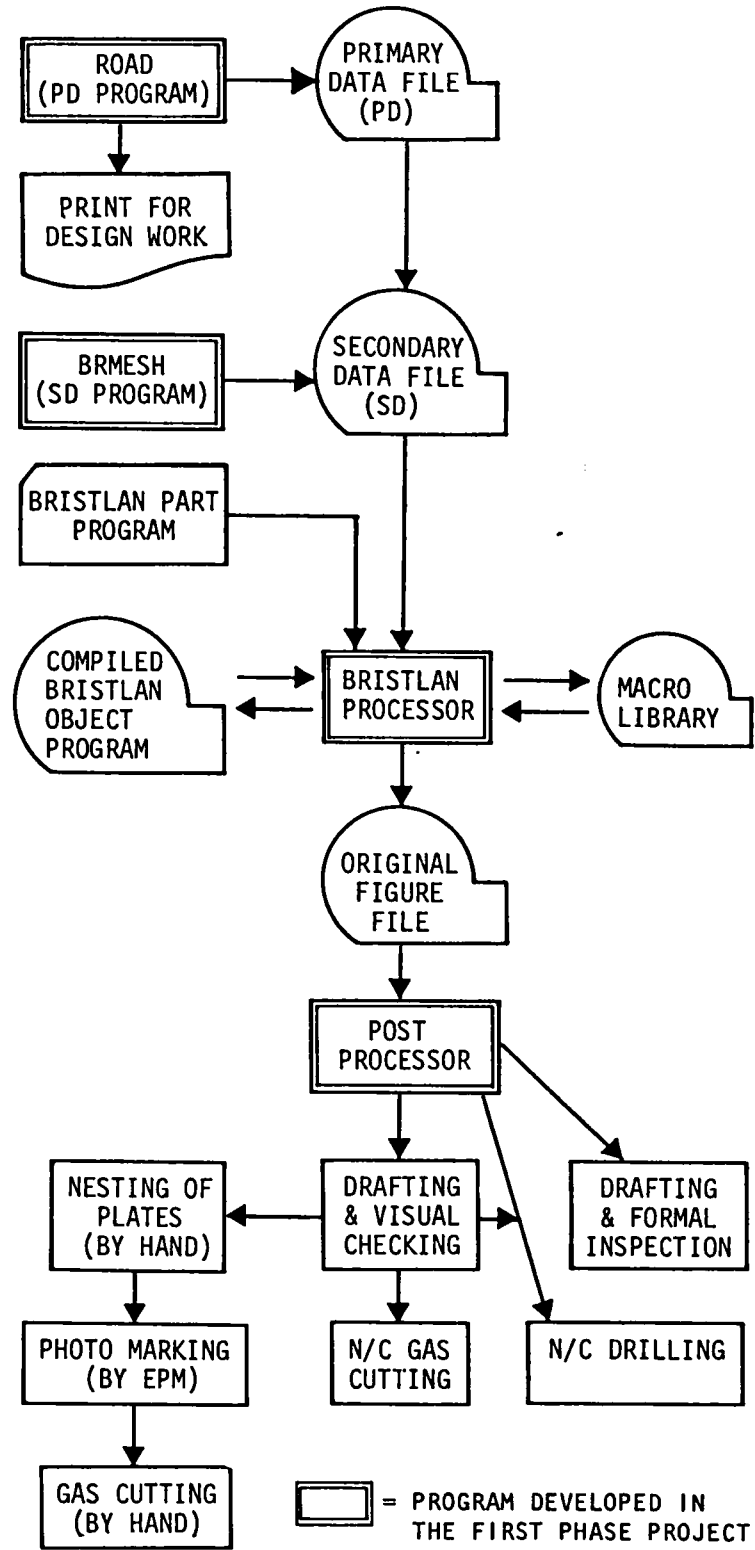

Fig. 3-3 BRISTLAN System Flow (Original Form)

GEOMETRIC STATEMENTS

1) Definition of Points			
<p>Point Coordinate</p>  <p>PTCO A/B</p>	<p>Point Intersection</p>  <p>PTIT {S,C,F}/(S,C,F)/[(P,T)]</p>	<p>Point Girth</p>  <p>PTGH (P,T)/(S,C,F)/A</p>	<p>Point Stiffener</p>  <p>PTST {P,T}/(S,C,F)/[(P,T)]</p>
<p>Point Tangent</p>  <p>PTTN {P,T}/(C,F)/[(P,T)]</p>	<p>Point Normal</p>  <p>PTNR {P,T}/(S,C,F)/[(P,T)]</p>	<p>Point of Circle Center</p>  <p>PTCC C</p>	<p>Point Ratio</p>  <p>PTRT {S,C,F}/(A)/[A]</p>
2) Definition of Lines			
<p>Line Vertical Up</p>  <p>LNVD {P,T}/ {S,C,F} / {S,C,F} / {A} / {P,T} / {A} / {P,T} / {NT}</p>	<p>Line Vertical Down</p>  <p>LNVD {P,T}/ {S,C,F} / {S,C,F} / {A} / {P,T} / {A} / {P,T} / {NT}</p>	<p>Line Horizontal Small</p>  <p>LNHS {P,T}/ {S,C,F} / {S,C,F} / {A} / {P,T} / {A} / {P,T} / {NT}</p>	<p>Line Horizontal Large</p>  <p>LNHL {P,T}/ {S,C,F} / {S,C,F} / {A} / {P,T} / {A} / {P,T} / {NT}</p>
<p>Line Stiffener</p>  <p>LNST {P,T}/ (S,C,F)/A/ [(S,C,F)]/[(P,T)]</p>	<p>Line Tangent</p>  <p>LNTN {P,T}/(C,F)/ [(S,C,F)]/[(P,T)]</p>	<p>Line Normal</p>  <p>LNNR {P,T}/(S,C,F)/ [(S,C,F)]/[(P,T)]</p>	<p>Line Point</p>  <p>LNPT {P,T}/(P,T)</p>

FIG. 3-4 Geometric, Special and Logical Statements in BRISTLAN

/: Delimiter of operands
 { }: Option
 []: Omissible modifier
 NT: Point Nest

GEOMETRIC STATEMENTS (Continued)

3) Definition of Arcs			
<p>Circle Center Radius</p>  <p>CRCR {P,T}/A/[A]/[A]</p>	<p>Circle Two Points</p>  <p>CR2P {P,T}/(P,T)/A</p>	<p>Circle Point Tangent</p>  <p>CRPT {P,T}/A/{S,C,F} NT</p>	<p>Circle Two Point Tangent</p>  <p>CR2C {P,T}/(P,T)/{S,C,F} NT</p>
<p>Circle Two Tangents</p>  <p>CR2T A/{S,C,F}/(S,C,F) NT</p>	<p>Circle Three Points</p>  <p>CR3P {P,T}/(P,T)/(P,T)</p>	<p>Circle Three Tangents</p>  <p>CR3T {S,NT}/(S,NT)/(S,NT)</p>	
4) Definition of Curves			
<p>Linearly Interpolated Curve</p>  <p>FIGS {P(I)}/(P(J)) T(I)</p>	<p>A Circular Interpolated Curve</p>  <p>FIG1 {P(I)}/(P(J)) T(I)</p>	<p>Two Circular Interpolated Curve</p>  <p>FIG2 {P(I)}/(P(J)) T(I)</p>	
5) Modification of Figures			
<p>Parallel</p>  <p>PARA {S,C,F}/A NT</p>	<p>Back</p>  <p>BACK {S,C,F} NT</p>	<p>Cut of Figures</p>  <p>CUTF {S,C,F}/ NT [S,C,F] P,T A NT / [S,C,F] P,T A HT</p>	<p>Join Figures</p>  <p>JOIN {S,C,F}/(S,C,F)</p>

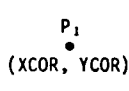
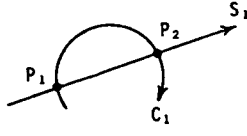
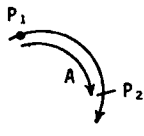
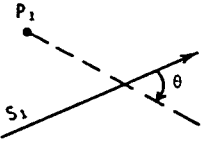
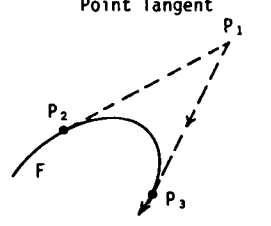
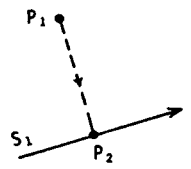
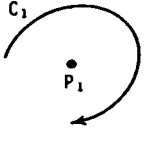
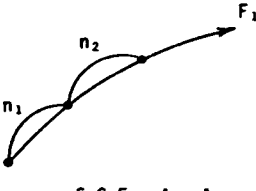
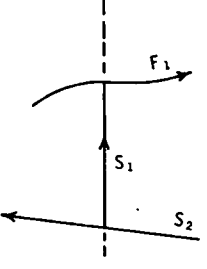
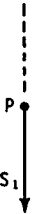
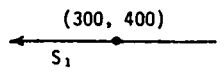
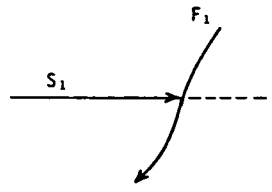
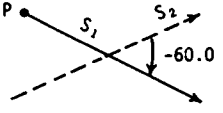
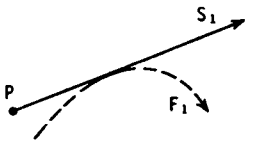
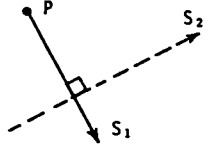
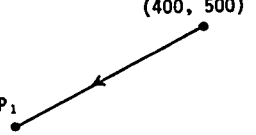
FIG. 3-4 (continued)

<p>Combine Figures</p> <p>COMB $\left\{ \begin{matrix} S,C,F \\ NT \end{matrix} \right\} / \left\{ \begin{matrix} S,C,F \\ NT \end{matrix} \right\} / \{ (P,T) \}$</p>	<p>Mirror</p> <p>MIRR $\left\{ \begin{matrix} S,C,F \\ P,T \\ NT \end{matrix} \right\} / \left\{ \begin{matrix} S \\ NT \end{matrix} \right\}$</p>	<p>Move</p> <p>MOVE $\left\{ \begin{matrix} S,C,F \\ P,T \end{matrix} \right\} / \{ (P,T) \} / \left\{ \begin{matrix} S,C,F \\ NT \\ A \end{matrix} \right\}$</p>	<p>Shift</p> <p>SHFT $\left\{ \begin{matrix} S,C,F \\ P,T \end{matrix} \right\} / A/A / \{ (P,T) \} / \left\{ \begin{matrix} A \\ S \\ NT \end{matrix} \right\}$</p>
<p>SPECIAL STATEMENTS</p>			
<p>Distance Normal to Figure</p> <p>DIST $\left\{ \begin{matrix} P,T \\ NT \end{matrix} \right\} / \left\{ \begin{matrix} S,C,F \\ NT \end{matrix} \right\} / \{ (P,T) \}$</p>	<p>Distance Between Two Points</p> <p>DISP $\{ (P,T) \} / \{ (P,T) \}$</p>	<p>Spacing Between Two Points</p> <p>SPAC T/T</p>	<p>Girth Length</p> <p>GIRH $\{ (P,T) \} / \{ (P,T) \} / \left\{ \begin{matrix} S,C,F \\ NT \end{matrix} \right\}$</p>
<p>Radius of Circle</p> <p>RADI C</p>	<p>Angle</p> <p>ANGL $\left\{ \begin{matrix} S,C,F \\ NT \end{matrix} \right\} / \left\{ \begin{matrix} S,C,F \\ NT \end{matrix} \right\}$</p>	<ul style="list-style-type: none"> $\begin{Bmatrix} X \\ Y \\ Z \end{Bmatrix}$ Coordinates $\begin{Bmatrix} XCOR \\ YCOR \\ ZCOR \end{Bmatrix} \{ (P,T) \}$ Assign $ASSN \begin{Bmatrix} A \\ P,T \\ W,I \end{Bmatrix} / \begin{Bmatrix} A \\ P,T \\ W,I \end{Bmatrix}$ Coordinate Translation $\{ (P,T) \} TRAS \{ (P,T) \}$ 	<ul style="list-style-type: none"> Built-in Function $\begin{Bmatrix} ADD \\ SUB \\ MUL \\ DIV \end{Bmatrix} \begin{Bmatrix} A \\ I \end{Bmatrix} \begin{Bmatrix} A \\ I \end{Bmatrix}$ $\begin{Bmatrix} SIN \\ COS \\ ATAN \\ ASIN \end{Bmatrix} \{ A \}$ $\begin{Bmatrix} SQRT \\ ABS \end{Bmatrix} \{ A,I \}$ SIGN $\{ A,I \} / \{ A,I \}$
<p>LOGICAL STATEMENTS</p>			
<p>On the Line (ON)</p> <p>IF TRUE ON F/P (If P is on F, jump to 'TRUE')</p>	<p>In the Positive (PLUS) Region</p> <p>IF 100 PLUS F/P (If P is in plus region, jump to 100)</p>	<p>Root (RT0,RT1,RT2,RT3)</p> <p>IF 200 RT2 F/S (If there are two intersections between F and S, jump to 200)</p>	<ul style="list-style-type: none"> Equal (EQ) Greater (GT) <p>IF 300 EQ A/B (If A is equal to B, jump to 300)</p>

Fig. 3-4 (continued)

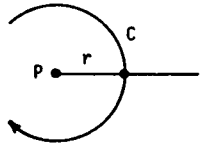
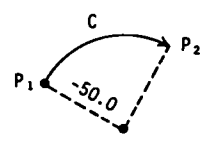
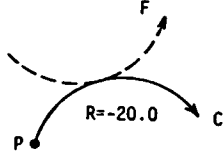
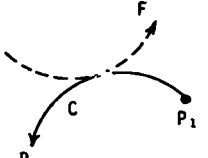
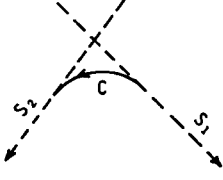
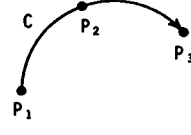
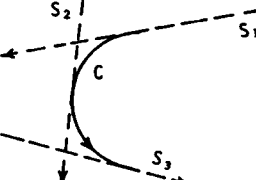
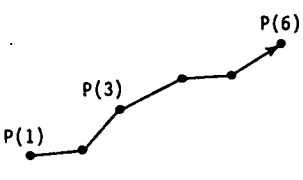
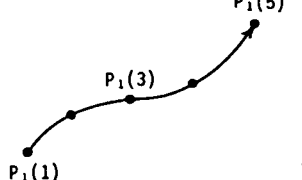
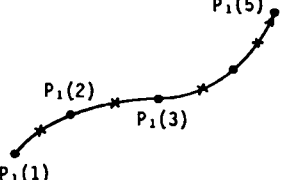
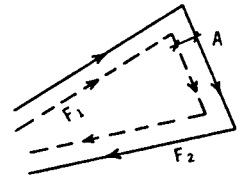
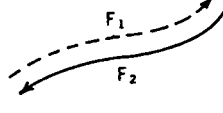
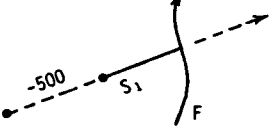
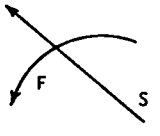
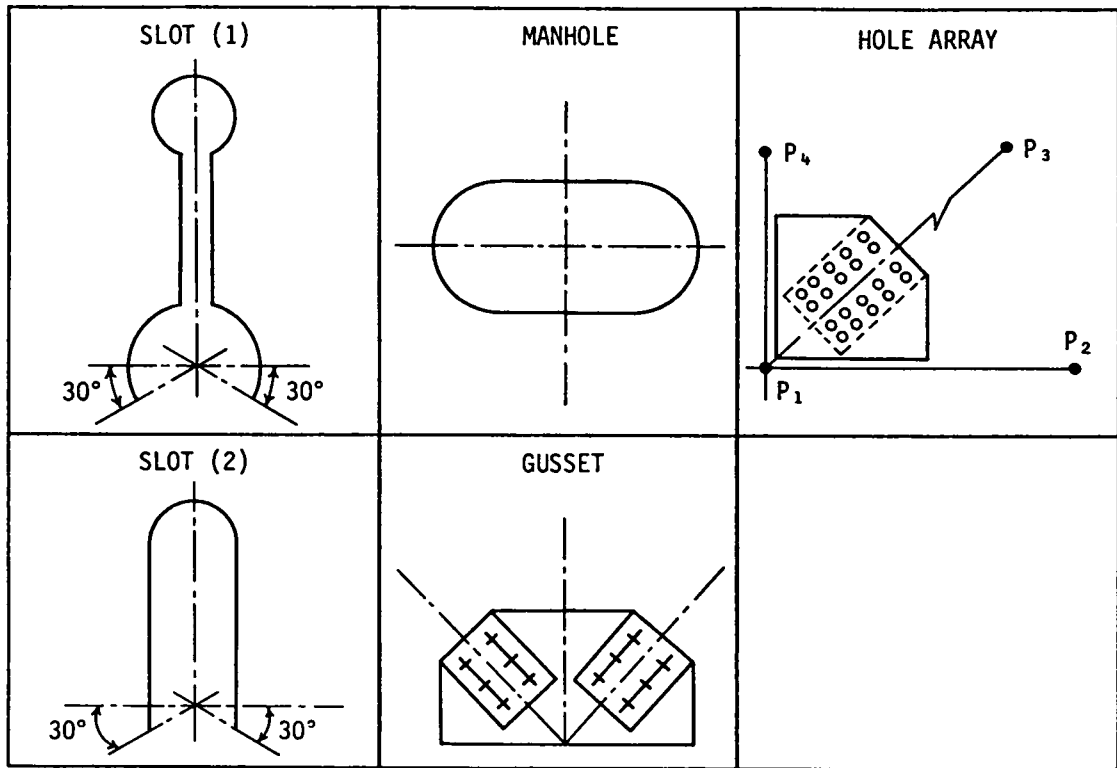

(a) Macro Library in BRISTLAN

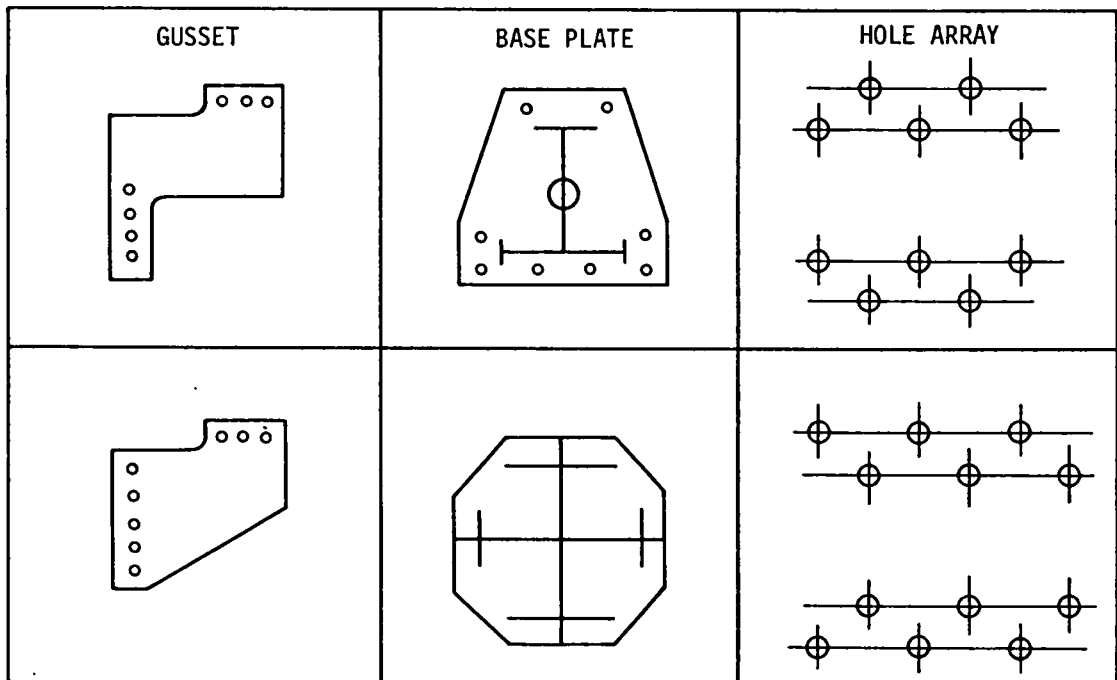

(b) Menu in BRISTLAN 2

Fig. 3-5 Standard Patterns in Macro Library and MENU

GENERAL FORMAT

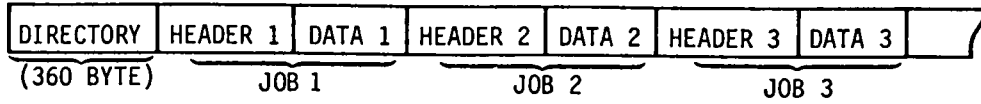

DIRECTORY (360 BYTE)

	JOB NAME (*8)	INITIAL ADDRESS (*4)
1	FILE NAME	5 (Index Number)
2	C-0001	30
3	C-0002	180
4	C-0003	960
5	C-0004	1740
:		
:		
:		
:		
30		

HEADER (600 BYTE) (Ex. C0002)

	(*4) LABEL	(*2) DISP	(*2) I-max	(*2) J-max	(*2) K-max
1	4 (Index Number)	C-	00	02	
2	TWUF	0	2	7	17
3	TWMF	240	2	17	17
4	TWLF	480	2	17	17
5					
:					
:					
:					
:					
50					

(ORIGINAL)
SECONDARY DATA

	COORDINATE		
	X-COR (*8)	Y-COR (*8)	Z-COR (*8)
1			
2			
3			
:			
:			
:			
n			

ATTRIBUTE CODE (*4=32 BITS)

1	STIFFENER
2	END
3	SUPPORT
4	JOINT
5	LATERAL
6	WEB CUT
7	UPPER FLANGE CUT
8	LOWER FLANGE CUT
9	UPPER
10	MIDDLE
11	LOWER
12	LEFT
13	RIGHT
14	BACKWARD
15	CENTER
16	FORWARD
17	
18	
19	
20	
21	
22	
23	
24	
25	
26	
27	
28	
29	
30	
31	
32	

REVISED SECONDARY DATA

	ATTRIBUTE CODE	LINK CODE	COORDINATE		
	A-CODE (*4)	L-CODE (*4)	X-COR (*8)	Y-COR (*8)	Z-COR (*8)
1					
2					
3					
4					
:					
:					
:					
:					
n					

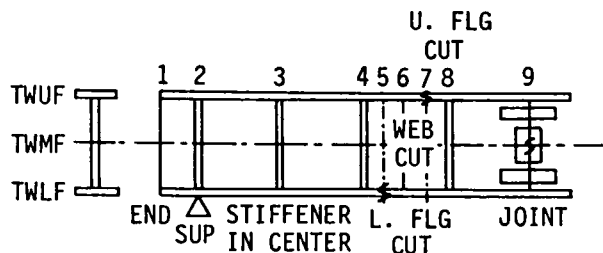

Fig. 3-6 Secondary Data Structure

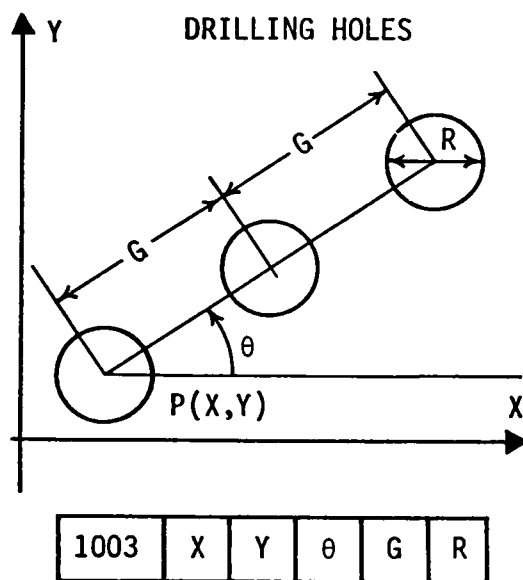
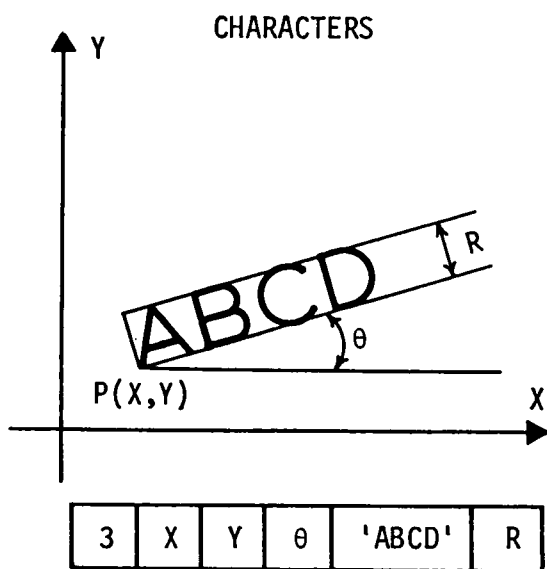
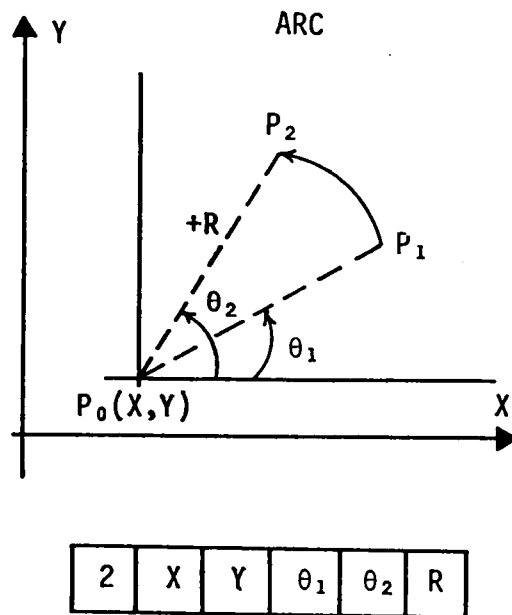
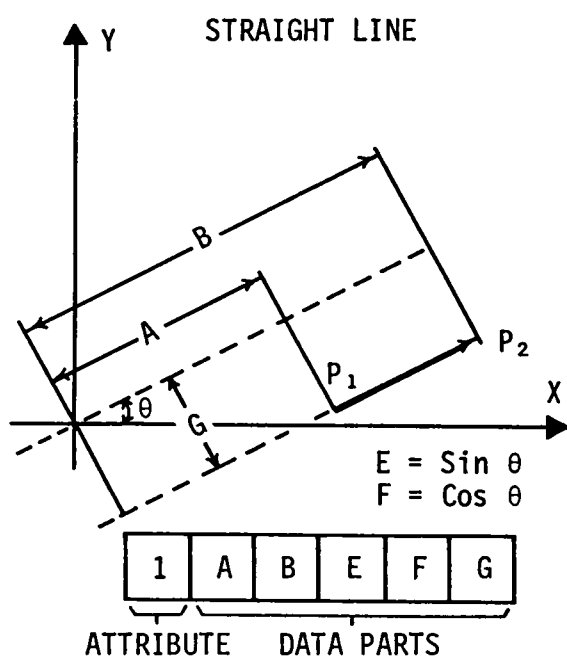
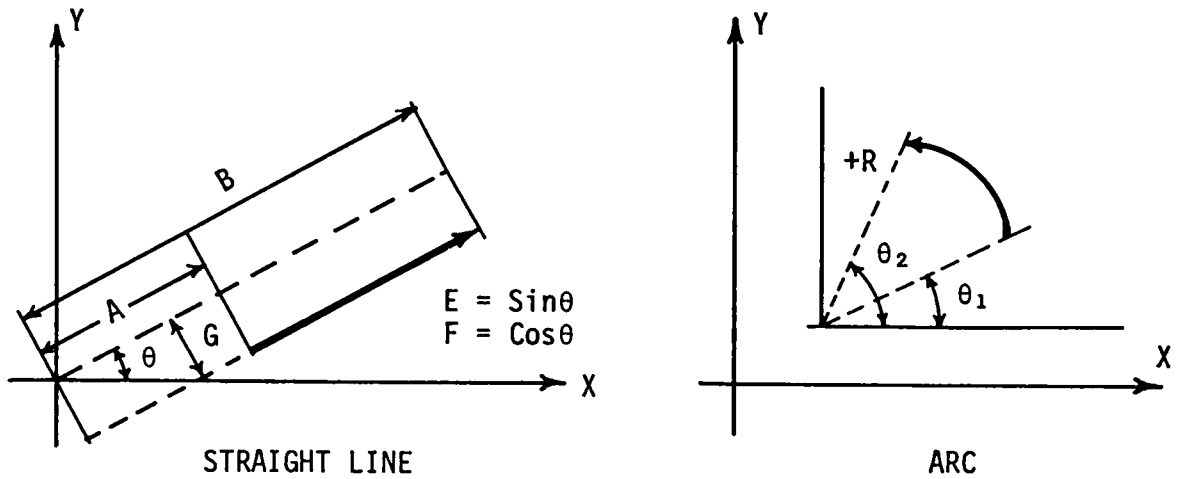

Fig. 3-7 Segment Lists (Expression of Figures)



	STRAIGHT LINE						ARC					
ORIGINAL	1	A	B	E	F	G	2	X	Y	θ_1	θ_2	R
PARALLEL	1	A	B	E	F	$G \pm \Delta G$	2	X	Y	θ_1	θ_2	$R \pm \Delta R$
BACK	1	B	A	-E	-F	-G	2	X	Y	θ_2	θ_1	-R
CUT	1	$A \pm \Delta A$	$B \pm \Delta B$	E	F	G	2	X	Y	$\theta_1 \pm \Delta \theta_1$	$\theta_2 \pm \Delta \theta_2$	R
SHIFT	1	$A \pm \Delta D$	$B \pm \Delta D$	E	F	$G \pm \Delta G$	2	$X \pm \Delta X$	$Y \pm \Delta Y$	θ_1	θ_2	R
ROTATE	1	A	B	$E \pm \Delta E$	$F \pm \Delta F$	G	2	X	Y	$\theta_1 \pm \Delta \theta_0$	$\theta_2 \pm \Delta \theta_0$	R

Fig. 3-8 Modification of Figures Based on Segment Lists

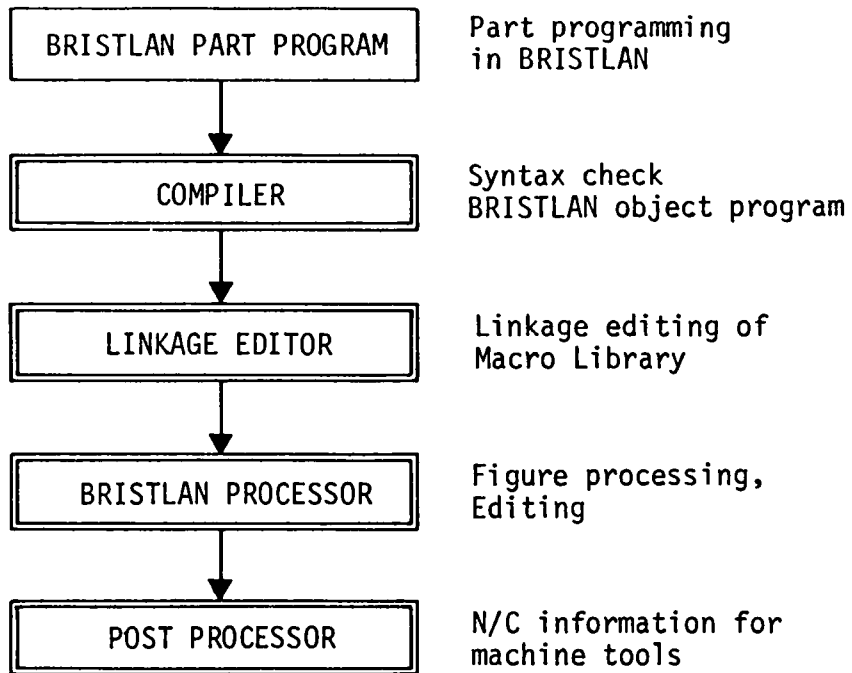

Fig. 3-9 Data Processing in BRISTLAN

General Form		
CRCR	{P,T}/A/[A]/[A]	
(ex) CRCR	500., 750./-99.0	

		Rule						M=6
		(1)	(2)	(3)	(4)	(5)	(6)	(7)
ICOND(1)	CRCR	X	X	X	X	X	X	Else
(2)	OPERAND1, P (Point)	X		X	X			
(3)	T (Solid)			X			X	X
(4)	OPERAND2, A (Scalar)	X	X	X	X	X	X	
(5)	OPERAND3, A (Scalar)			X		X		
(6)	OPERAND4, A (Scalar)				X		X	
N=(7)	OPERAND5, None							
(1)	No Description Error	X	X	X	X	X	X	
(2)	BRS1005 OPERAND DESCRIPTION ERROR							X

Example
 [ICOND(1) are set by INTERPRETER)
 ICOND(1) = 1
 ICOND(2) = 1
 ICOND(3) = 0
 ICOND(4) = 1
 ICOND(5) = 0
 ICOND(6) = 0
 ICOND(7) = 0

```

DIMENSION IRULE(42), ICOND(7)
DATE IRULE / 1, 1, 0, 1, 0, 0, 0, ---- (Rule 1)
*          1, 0, 1, 1, 0, 0, 0, ---- (Rule 2)
*          1, 1, 0, 1, 1, 0, 0, ---- (Rule 3)
*          1, 1, 0, 1, 0, 1, 0, ---- (Rule 4)
*          1, 0, 1, 1, 1, 0, 0, ---- (Rule 5)
*          1, 0, 1, 1, 0, 1, 0 / --- (Rule 6)

MATCH=0
N=7 (Number of Conditions)
M=6 (Number of Rules)
DO 11 J=1,M
DO 12 I=1,N
IF (ICOND(I).NE.IRULE((J-1)*N+1) TO TO 11
12 CONTINUE
MATCH=MATCH+1
11 CONTINUE
IF(MATCH.EQ.0) CALL ERROR (1005)
RETURN
END
  
```

Fig. 3-10 An example of description error checking by decision table

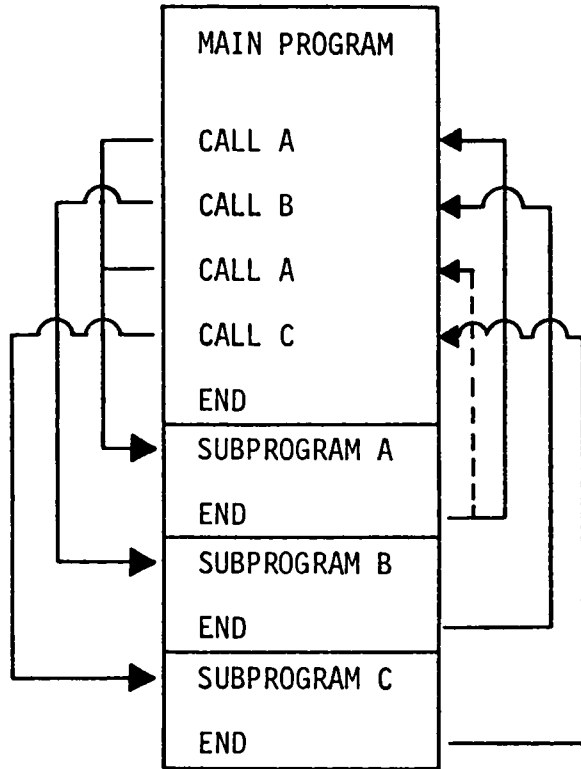
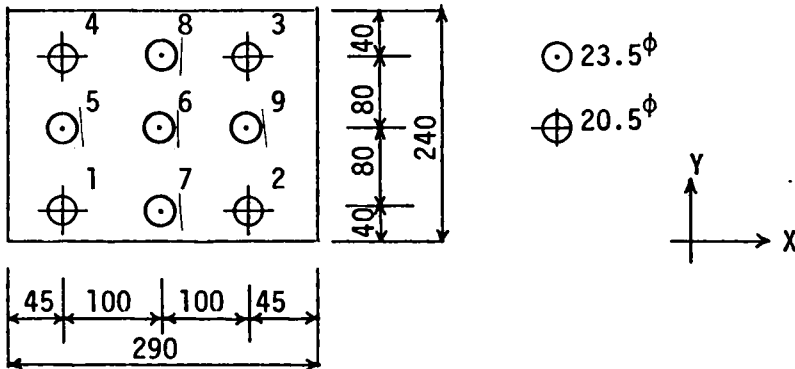

Fig. 3-11 Feature of Object Program by Linkage Editor in BRISTLAN



Punching in Paper Tape

,N001X + 4500Y + 4000\$N002X + 24500\$N003Y + 20
 000\$N004X + 4500\$N005Y + 12000T\$N006X + 1450
 0Y + 4000\$N007Y + 12000\$N008Y + 20000N0009X + 2
 4500Y + 12000\$/

Instruction of a Drilling Machine

Key Punch	Comment
0	0
∫	∫
9	9
Blank	b
+	Plus
-	Minus
X	X-axis
Y	Y-axis
N	Sequence No
T	Tool Change
CR	End of Block
,	Rewind then Stop
/	Rewind
DE	Delete

Part-programming

RW,RWS	NO			TOOL	CR
RWS (,)	N001	X+4500	Y+4000	T	CR
	N002	X+24,500			CR
N003		Y+20,000	CR		
N004	X+4500		CR		
N005		Y+12,000	CR		
N006	X+14,500	Y+4000	CR		
N007		Y+12,000	CR		
N008		Y+20,000	CR		
RW (/)	N009	X+24,500	Y+12,000		CR

EIA 8 CODE
 OSP-821-A(DS-N)
 (Ōkuma Tēkousho)

Fig. 3-13 Drilling Machine Information

	ESSI	TOYO	MUTO (1)	MUTO (2)	PLOTTER	
Name of Drafter	Kingmatic MK-I Mod 1	TDM-617L		Numericon	CALCOMP 763/780	
Maker	ESSI & Kongsberg	TOYO DENKI	MUTO KOGYO	MUTO KOGYO	CALCOMP CO.	
Control Unit	Kingmatic MK-I Mod 2	TNC 3000	FANUC 250	FANUC 230	CALCOMP 780	
Country	Norway	Japan	Japan	Japan	U.S.A.	
Drawing Zone	1200 x 1500 m/m	600 x 1200 m/m	1500 x 3600 m/m	850 x 1200 m/m	750 x 36500 m/m	
Moving Increment	1 m/m	0.05 m/m	0.02 m/m	0.04 m/m	0.012 m/m, 0.006 m/m	
Speed (m/min)	Max 4. 3.2 1.6	0.6 & 1.2 0.8 (Max 1.2)	2.4	2.4 (4.8)	3.4 ~ 18.1	
Scaling	$\frac{1}{10}, \frac{1}{20}, \frac{1}{25}, \frac{1}{50}, \frac{1}{100}, \frac{1}{200}$	$\frac{1}{1}, \frac{1}{2}$	$\frac{1}{1}$	$\frac{1}{1}$	$\frac{1}{1}$	
Accuracy	0.075 m/m	0.075 m/m	0.075 m/m	0.01 m/m	0.006 ~ 0.012 m/m	
Pen line	Solid, Dashed	Solid, Dashed	Solid, Dashed	Solid	Solid, Dashed	
Pen Selection	1	2	3	1 (2 surface)	1	
Code	EIA 8 Channel Punched Tape	EIA 8 Channel Punched Tape	EIA 8 Channel Punched Tape	EIA 8 Channel Punched Tape	Magnetic Tape (800 BPI)	
Read Speed	300 ch/sec	200 ch/sec	200 ch/sec	200 ch/sec	152 ⁴ cm/sec	
Digit Expression	Fixed Decimal	Hexa Decimal	Fixed Decimal	Fixed Decimal	Hexa Decimal	
Instruction Code	Line	Refer to Control Information	"	"	Line control only	Line control only
	Arc				-	-
	Parabola				-	-
	X-CONVERSION	21*	X	21*	-	-
	Y-CONVERSION	27*	Y	27*	-	-
	45°-CONVERSION	-	S1-S2	-	-	-
	Solid	6*	I	6*	-	-
	Dashed	5*	J	5*	-	-
	Pen Up	8*	U	8*	M5*(XY), M7*(XV)	-
	Pen Down	7*	D	7*	M4*(XY), M6*(XV)	-
	Pen Change	-	P1-P2	D31*, D32*, D33*	-	-
	Halt	-	H	0*	-	-
Reset	0*	0	-	-	-	

Fig. 3-14 Drafter Mechanism

	ESSI	TOYO	MUTO (1)	MUTO (2)	PLOTTER
 <p>Y Straight line ($\Delta X, \Delta Y$) X</p>	$\pm\Delta X\pm\Delta Y^*$	F a/ $\Delta X/\Delta Y$ [a = $\Delta Y/\Delta X$]	$\pm\Delta X\pm\Delta Y^*$	FOX Δx Y Δy Z Δz^*	Full Step 0.005 inch 
 <p>Y Arc ($\Delta X, \Delta Y$) X</p>	$\pm\Delta X\pm\Delta Y\pm XC\pm YC$ -* $\pm\Delta X\pm\Delta Y\pm XC\pm YC$ +*	Clockwise R p/a/ $\Delta X/\Delta Y$ Counterclockwise L p/a/ $\Delta X/\Delta Y$ ($Y^2+pY=-X^2+aX$)	$\pm\Delta X\pm\Delta Y\pm XC\pm YC$ -* $\pm\Delta X\pm\Delta Y\pm XC\pm YC$ +*		
 <p>Y $Y=aX+bX^2+cX^3$ ($\Delta X, \Delta Y$) X</p>		T a/b/c/ $\Delta X/\Delta Y$ ($Y=aX+bX^2+cX^3$)			
 <p>Y Parabola ($\Delta X, \Delta Y$) XP YP X</p>	Clockwise $\pm\Delta X\pm\Delta Y\pm XP\pm YP$ -+* Counterclockwise $\pm\Delta X\pm\Delta Y\pm XP\pm YP$ ++*	T a/b/o/ $\Delta X/\Delta Y$ ($Y=aX+bX^2$)			
 <p>Y Parabola ($\Delta X, \Delta Y$) YP XP X</p>	Clockwise $\pm\Delta X\pm\Delta Y\pm XP\pm YP$ --* Counterclockwise $\pm\Delta X\pm\Delta Y\pm XP\pm YP$ +-*	T a/b/o/ $\Delta X/\Delta Y$ ($Y=aX+bX^2$)			
REMARKS	ESSI FORMAT		ESSI FORMAT		

Fig. 3-15 Instruction Formats of Drafters



BSL			'BRISTLAN'
JOB			
DEBG	TRAC		
SCAL			1/10
PNUM			'EXAMPLE 1'/400.,1200.
MATR			SS41/9.0
CALL	F	SL01	9.0/110.0/25.0/35.0/1.0
CONT			
STPT	P	PTCO	-1.0/-1.0
		LNHL	P
		LNVU	1001.0,0.0
	S	LNHS	0.0,1501.0
		MOVE	F/750.,1500./S
	S		
		MOVE	F/250.,1500./S
	S		
		LNVD	P
ENPT	P		
LAND			
STPT		CRCR	500.,750./-99.0
ENPT			
END			

Fig. 3-16 BRISTLAN Coding (1)
(Standard statements, use of CALL MACRO)

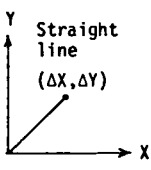
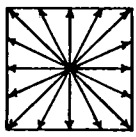
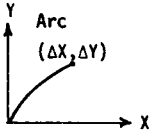
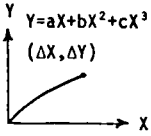
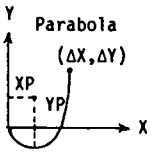
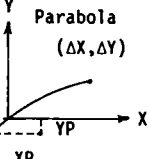
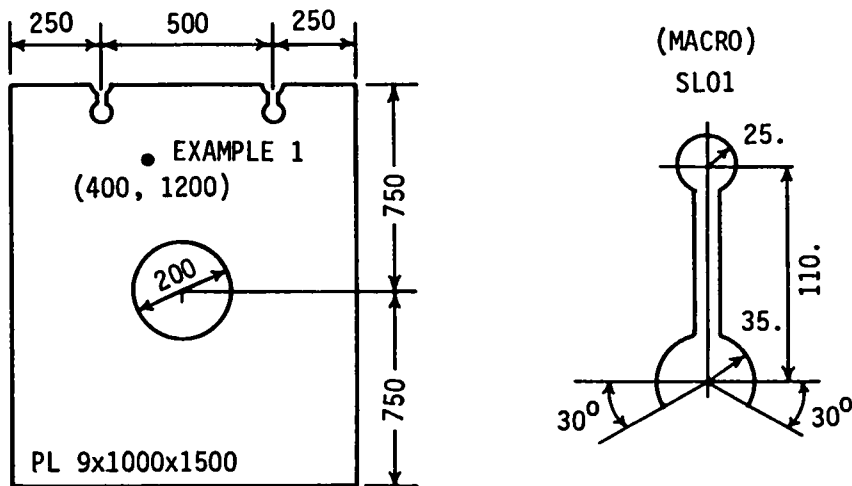
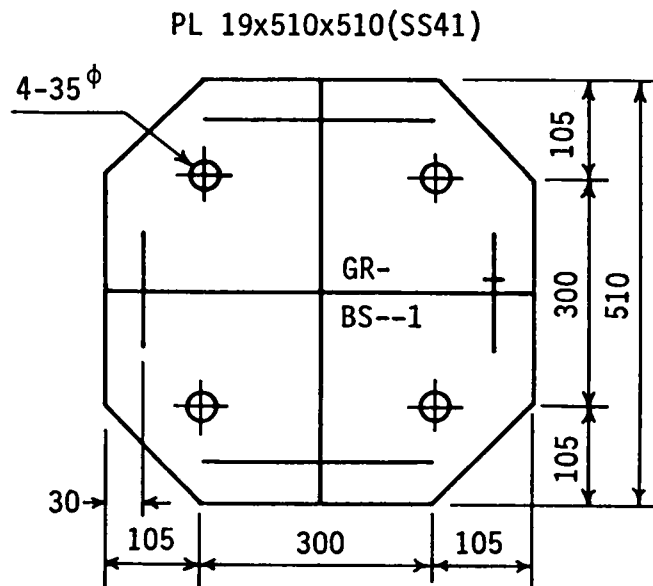

BSL			
JOB			'C-5060'
PNUM			'GR '/'BS-1'/0.0,0.0
MATR			'SS41'/19.0
LINK	F	CD08	-275.0/275.0/-150.0/150.0/-275.0/275.0/-150.0/150.0 * 0.0,0.0/0.0,0.0/1.0
MARK			
		LNvu	0.0,0.0/0.0,-275.0/0.0,275.0
	S1	LNHL	0.0,225./-150., 225.0/150.,225.0
		MIRR	S1/1000.0,0.0,-1000.0,0.0
		LNHL	0.0,0.0/-275.0,0.0/275.0,0.0
	S	LNvu	225.0,0.0/225.0,-75.0/225.0,75.0
		MIRR	S/0.0,-1000.0,0.0,1000.0
CROS	2		
HOLE			35.0/-150.0,-150.0/0.0/300.0/2
HOLE			35.0/-150.0,150.0/0.0/300.0/2
END			

Fig. 3-17 BRISTLAN Coding (2)
(A base plate, use of LINK MACRO)

LIST NO.	I(SEGCODE)	SEG(1,N)	SEG(2,N)	SEG(3,N)	SEG(4,N)	SEG(5,N)	X1	Y1	X2	Y2
1	24	C-5C6C	GR	BS-1	PLATL	0.100	-151.414	-276.000	151.414	-276.000
22	3	C.0	C.0	0.0	GR	3.000	151.414	-276.000	276.000	-151.414
23	3	C.0	-45.0CC	0.0	BS-1	3.000	276.000	-151.414	276.000	151.414
16	100	C.0	C.0	552.000	552.000	0.0	276.000	151.414	151.414	276.000
24	100	C.0	C.0	0.0	0.0	0.0	151.414	276.000	-151.414	276.000
25	121	C.0	0.0	0.0	0.0	0.0	-151.414	276.000	-276.000	151.414
26	1	-151.414	151.414	0.0	1.000	276.000	-276.000	-151.414	-151.414	-276.000
27	1	-88.C55	88.C55	0.707	0.707	302.227	151.414	-276.000	276.000	-151.414
28	1	-151.414	151.414	1.000	0.0	276.000	276.000	151.414	151.414	276.000
29	1	-88.C55	88.C55	0.707	-0.707	302.227	276.000	151.414	-151.414	276.000
30	1	-151.414	151.414	0.0	-1.000	276.000	151.414	276.000	-151.414	-276.000
31	1	-88.C55	88.C55	-0.707	-0.707	302.227	-151.414	276.000	-276.000	151.414
32	1	-151.414	151.414	-1.000	0.0	276.000	-276.000	151.414	-151.414	-276.000
33	1	-88.C55	88.C55	-0.707	0.707	302.227	-151.414	-276.000	-151.414	-276.000
14	123	C.0	C.0	0.0	0.0	0.0	0.0	-275.000	0.0	-275.000
35	1	-275.000	275.000	1.000	0.0	0.0	0.0	225.000	150.000	225.000
36	1	-150.000	150.000	0.0	1.000	-225.000	-150.000	225.000	150.000	-225.000
37	1	-150.000	150.000	0.0	1.000	225.000	-150.000	-225.000	150.000	-225.000
38	1	-275.000	275.000	0.0	1.000	0.0	-275.000	0.0	275.000	0.0
39	1	-75.000	75.000	1.000	0.0	225.000	225.000	-75.000	225.000	75.000
40	1	-75.000	75.000	1.000	0.0	-225.000	-225.000	-75.000	-225.000	75.000
11	111	C.0	C.0	0.0	0.0	0.0	0.0	-75.000	-75.000	75.000
41	1002	-150.000	150.000	0.0	300.000	17.500	-150.000	-75.000	150.000	75.000
42	1002	-150.000	150.000	0.0	300.000	17.500	-150.000	-75.000	150.000	75.000

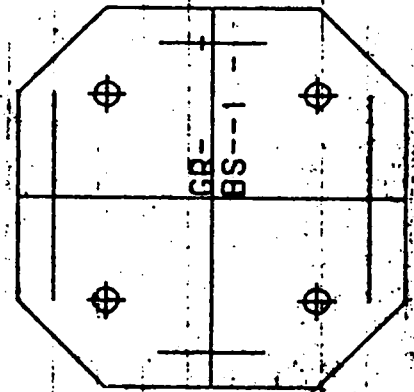

Fig. 3-18 Segment Lists associated with Fig. 3-17



图-13

```

BSL
JOB          "BRISTLAN"
DATA        TSU1/ TSL1/ TSC1
PLN1       TSL1(1,1,1)/ TSL1(1,2,1)/ TSU1(1,1,1)
PNL1       "TEST"/ 120.0, 60.0/ 12.0
COM1
NGN C1  CRCR  TSL1(1,1,1)/ -4.0/ 100.0/ -10.0
NGN S1  LNPT  TSL1(1,1,1)/ TSL1(1,2,1)
STPT P   PTIT  C1/S1
S1
NGN S2  LNVU  TSC1(1,1,1)
NGN S3  PARA  S1/ 40.0
          CR2T  -40.0/ S2/ S3
S3
NGN S4  LNVU  TSC1(1,2,1)
          CR2T  -40.0/ S3/ S4
S4
          CRCR  TSL1(1,2,1)/ -4.0/ -170.0/ 80.0
S5  LNPT  TSL1(1,2,1)/ TSU1(1,2,1)
          CRCR  TSU1(1,2,1)/ -4.0/ -80.0/ 170.0
          LNPT  TSU1(1,2,1)/ TSU1(1,1,1)
          CRCR  TSU1(1,1,1)/ -4.0/ 10.0/ -100.0
S6  LNPT  TSU1(1,1,1)/ TSL1(1,1,1)
C1
ENPT P
MARK
NGN S7  PARA  S1/ 41.0
          CR2F  S7/ S6/ S5
END
    
```

Fig. 3-19 BRISTLAN Coding (3)
(Sway bracing, use of Secondary Data)

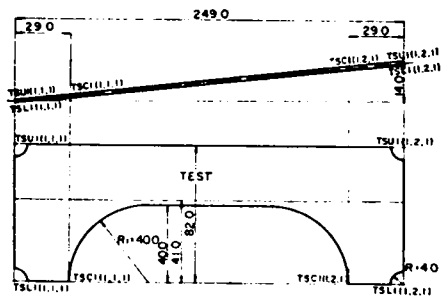
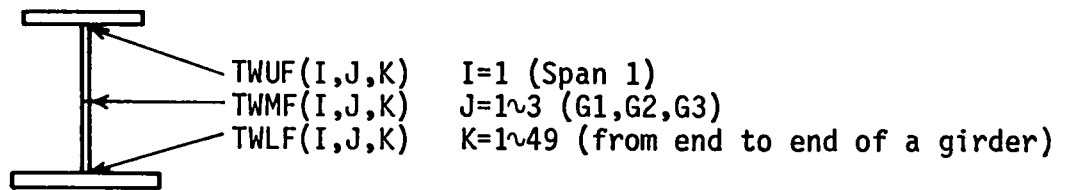
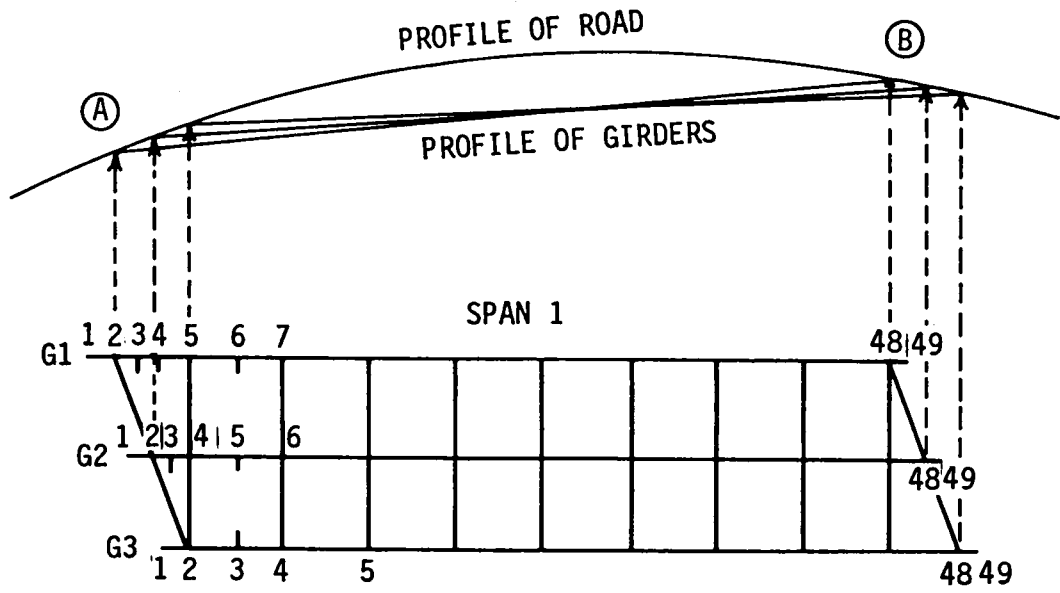

BSL			
JOB			C-4800-H
DATA			TWLF/TWUF
PLN2			TWLF(1,1,2)/TWLF(1,1,47)/TWUF(1,1,47)
		ASSN	I/0
LPST			3
		ASSN	J/0
	I	ADD	I/1
LPST			49
	J	ADD	J/1
	P	TRAS	TWLF(1,I,J)
WRIT			P
LPED			
LPED			
END			

Fig. 3-20 Rotation of Coordinate System of the Bridge Girders for Erection Work

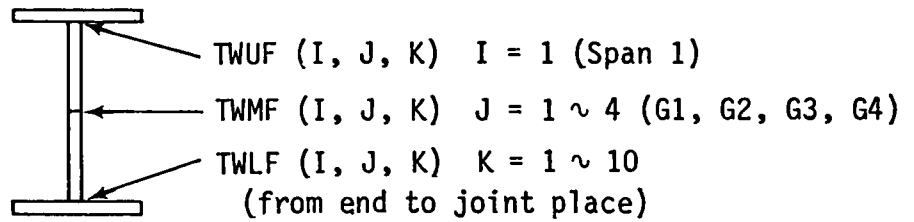
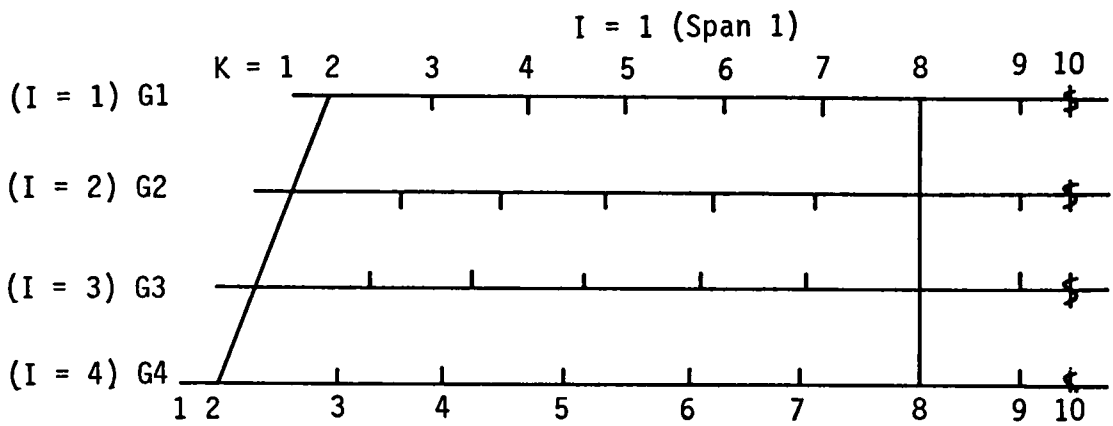

Fig. 3-21 Four Webs Drawings as Multiple Jobs in BRISTLAN

BRISTLAN VERSION(1)		PASS-1		TIME 160550
0001	RSL			
0002	JOB		C4850	
	CMNT		WEB SAGAN/GAWA 'N.IWAOKA' 11/8/69	
	DATA		TWUF / WLF / TWUF	
	ARRY	PII	10	
	ARRY	PM	10	
	ARRY	PL	10	
0003			ASSN	J / 0
0004	LPST			4
0005		J	ADD	J / 1
0006	PLN2			TWUF(1,J,2) / TWUF(1,J,10) / TWUF(1,J,10)
0007	PLN1			RW / 100.0 / 50.0
0008	MATR			SM50A / 9.0
0009			ASSN	K / 0
0010	LPST			10
0011		Y	ADD	K / 1
0012		P1	TRAS	TWUF(1,J,K)
0013		P2	TPAS	TWUF(1,J,K)
0014		P3	TPAS	TWLF(1,J,K)
0015			ASSN	PI(K) / P1
0016			ASSN	PI(K) / P2
0017			ASSN	PI(K) / P3
0018	WRIT			P1
0019	WRIT			P2
0020	WRIT			P3
0021	LPED			
	CONT			
0022	NON	FU	FIGS	PI(10) / PU(1)
0023	NON	FL	FIGS	PL(1) / PL(10)
0024	NON	SS	LNPT	PI(1) / PL(1)
0025	NON	SF	LNPT	PL(10) / PU(10)
0026	NON	FUE	CUTF	FU / 100.0 / 100.0
0027	NON	FLE	CUTF	FL / 100.0 / 100.0
0028	NON	SS	CUTF	SS / 100.0 / 100.0
0029	NON	SF	CUTF	SE / 100.0 / 100.0
0030	NON	SS	PARA	SS / -1.0
0031	NON	FLP	PARA	FLE / -2.0
0032	STPT	PC	PTIT	SS / FLP
0033		FLP		
0034		SF	PARA	SE / -11.0
0035			PARA	FUE / -2.0
0036		SS		
0037	LNPT	PS		
	MARK			
0038	NON	SD	LNPT	PI(2) / PL(2)
0039			PARA	SD / 8.0
0040			PARA	SD / -8.0
0041			ASSN	K / 2
0042	LPST			7
0043		K	ADD	K / 1
0044			ASSN	PDU / PI(K)
0045			ASSN	PDL / PL(K)
0046			PARA	PDL , PDU / 4.5
0047			PARA	PDU , PDL / 4.5
0048	LPED			
0049	NON	SD	LNPT	PI(10) / PI(2)
0050		SD	CUTF	SD / SF / SS
0051			PARA	FU / 265.5
0052		PS	PTGH	PI(2) / SD / -500.0
0053		PE	PTGH	PI(10) / SD / 500.0
0054			LNVD	PS / FU / FL
0055			LNVI	PE / FL / FU
0056	TF	100	EQ	J / 3
0057	GOTO	200		
0058	TURN	X		
0059	LPED			
0060	END			

Fig. 3-22 Part-programming of Fig. 3-21 by BRISTLAN

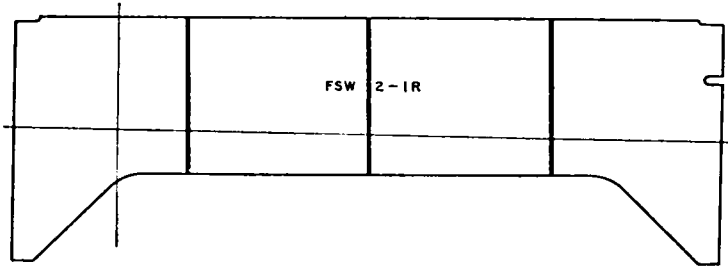
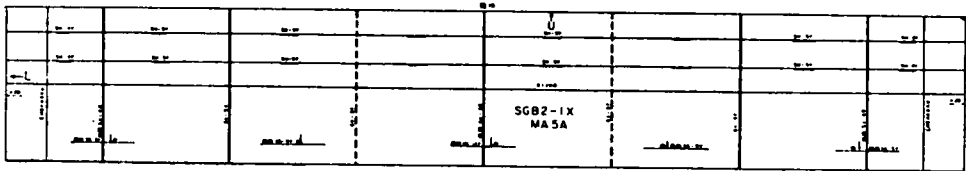

Fig. 3-23(a) N/C Drawings (Web and Bracing)

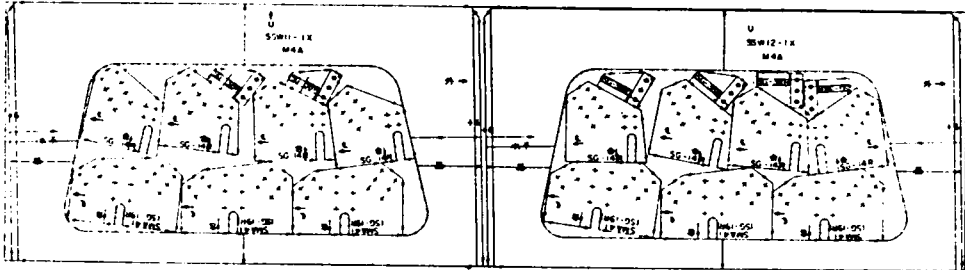

Fig. 3-23(b) N/C Drawings (Bracings and Gussets)

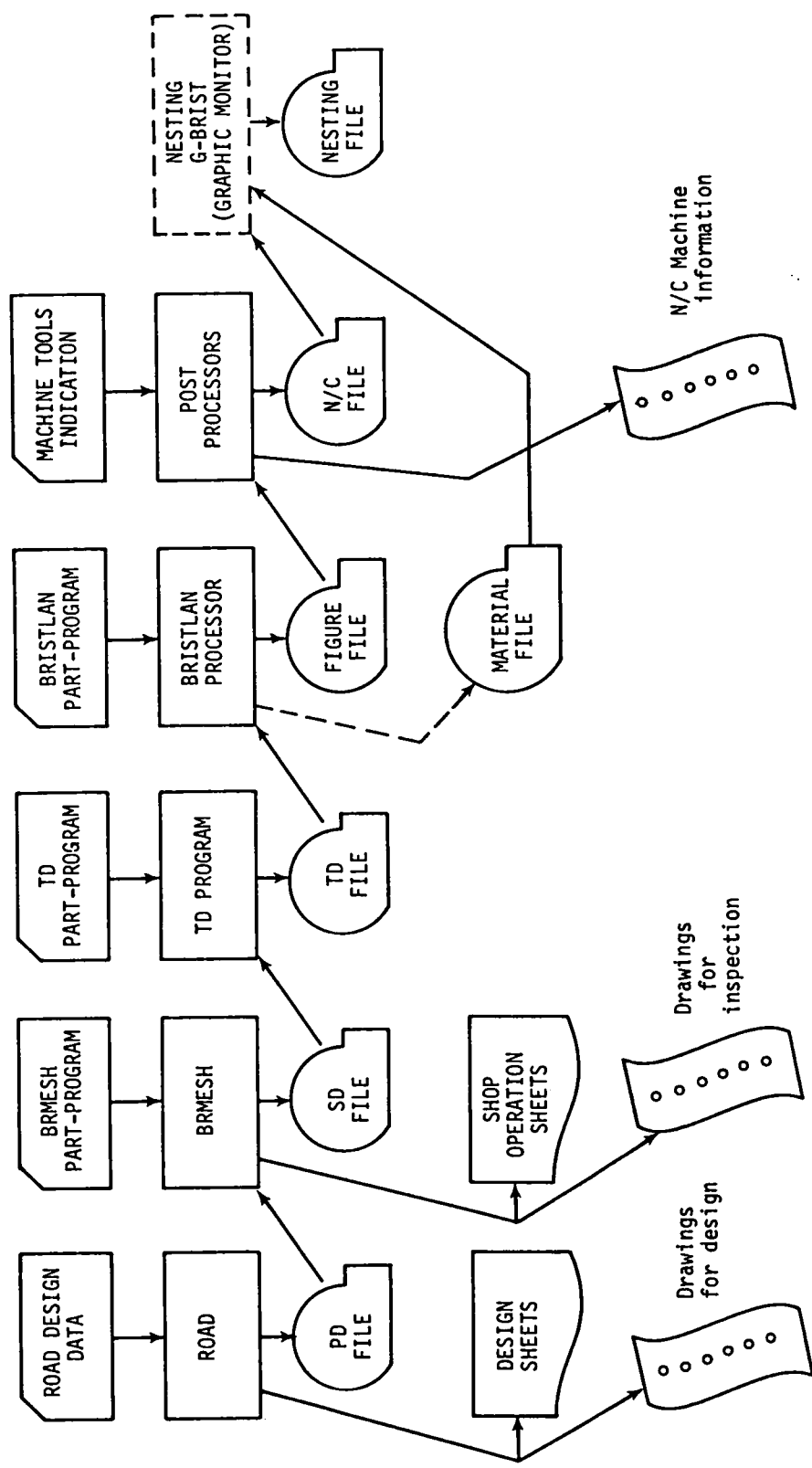

Fig. 3-24 The Revised BRISTLAN System

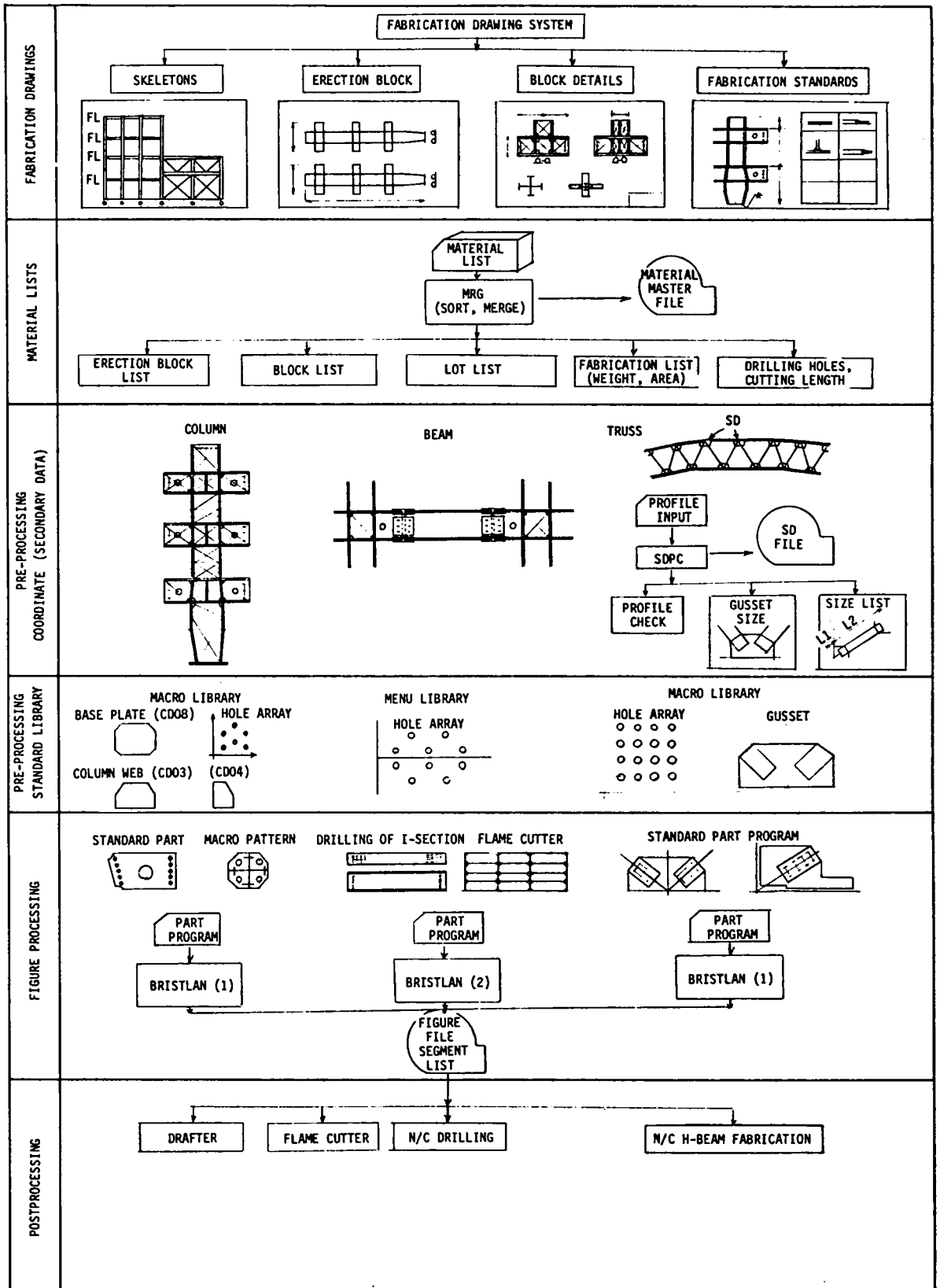

Fig. 3-26 N/C System in Building Frame

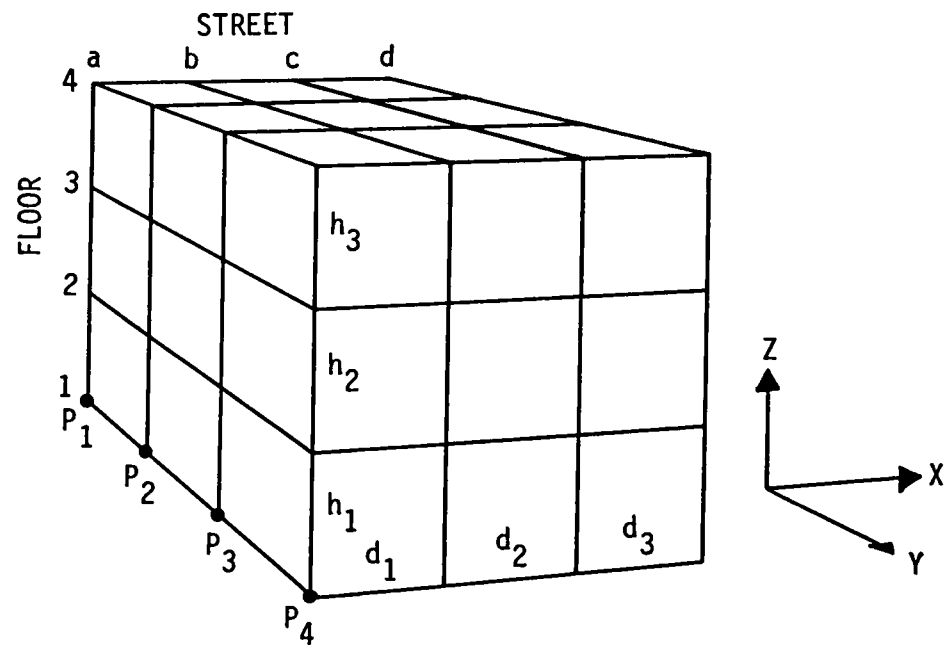

Fig. 3-27 Box Type Coordinate System in Building Frame

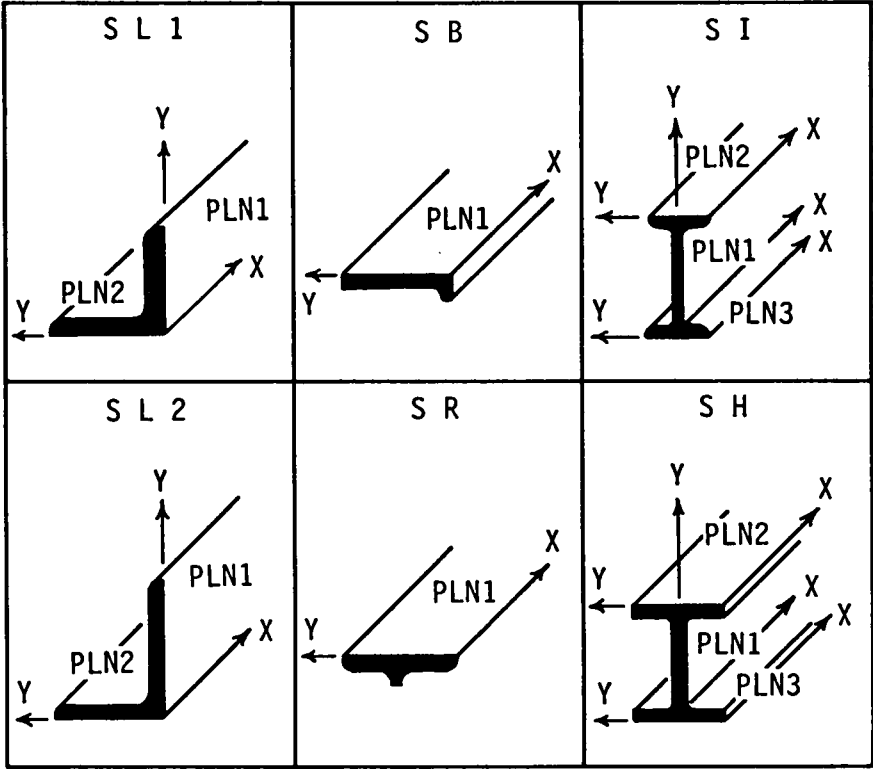
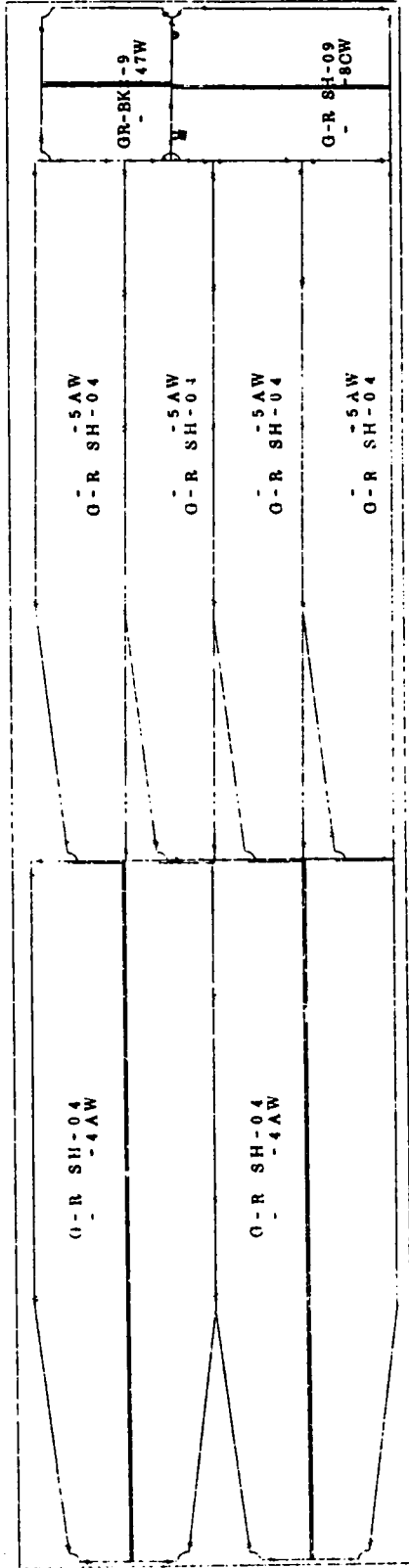

Fig. 3-29 Plane Definitions of Sections



図号	工番	材	寸法	数量	ロ-ル番号	チャ-ジ番号	切廻り	体長	担当	検図	作図
A-3	C-5060	SS4.	9X1524X6096	1	101022	202033	W-2	山下	N.N	K.K	S.S

Fig. 3-31 N/C Drawings of Nested Pieces in a Plate by BRISTLAN2

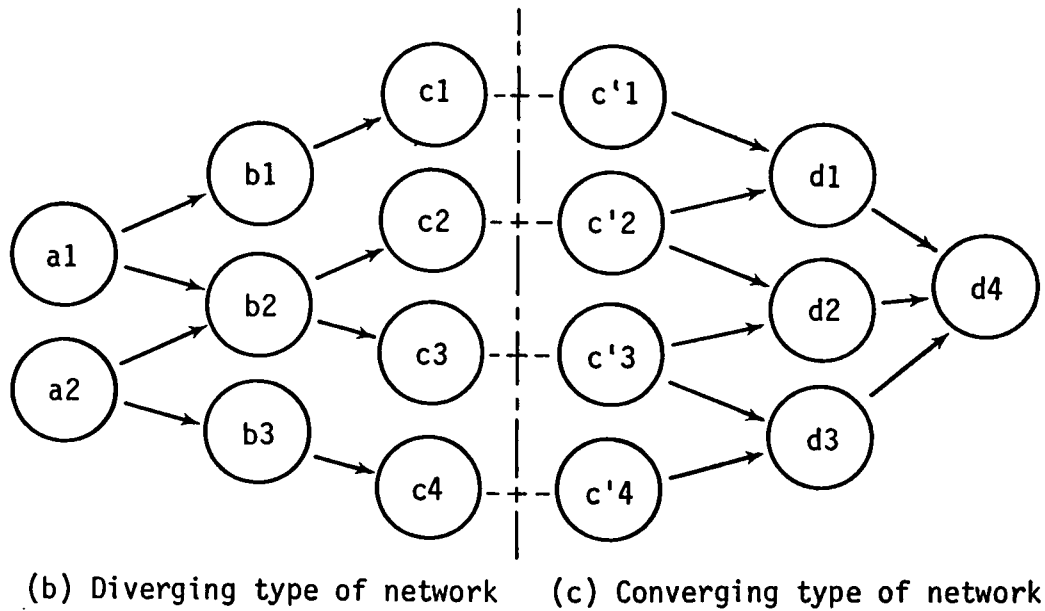
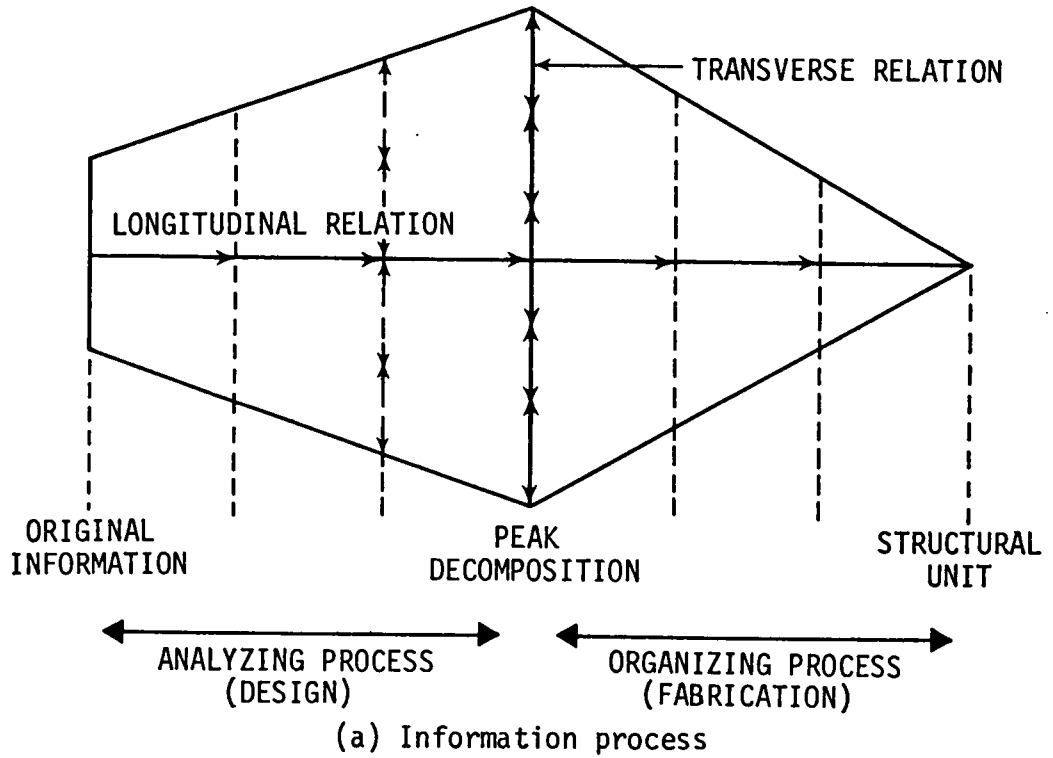
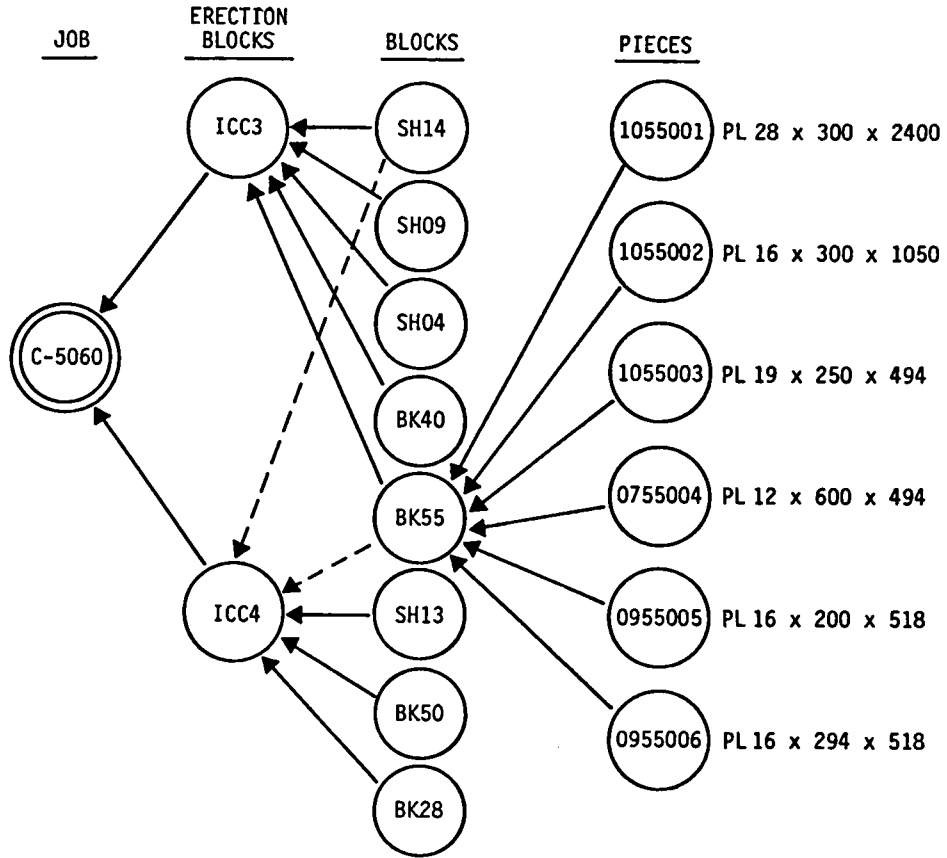

Fig. 3-32 A Model of Tree Structure in Design and Fabrication



NODE INFORMATION

ATTRIBUTE		FLAG (Valid, Void)	1
		NAME	
DEPENDENTS		FLAG	3
		NUMBER OF DEPENDENTS	4
		POINTER ADDRESS	5
INGREDIENTS		FLAG	6
		NUMBER OF INGREDIENTS	7
		POINTER ADDRESS	8
DRAWINGS	PLANE VIEW	FLAG	9
		NAME	10
	PROFILE VIEW	FLAG	11
		NAME	12
	SIDE VIEW	FLAG	13
		NAME	14
MANAGEMENT DATA (Shop Operation Lists)	WEIGHT	FLAG	15
		VALUE	16
		FUNCTION NAME	17
	PAINTING AREA	FLAG	18
		VALUE	19
		FUNCTION NAME	20
	CUTTING LENGTH	FLAG	21
		VALUE	22
		FUNCTION NAME	23
	DRILLING HOLE	FLAG	24
		VALUE	25
		FUNCTION NAME	26

DEPENDENTS TABLE	INGREDIENTS TABLE
1	1
2	2
3	3
4	4
5	5
6	6
7	7
8	8
9	9
10	10
11	11

Length = 4
(Number of Ingredients)

Fig. 3-33 A Network of Structural Elements

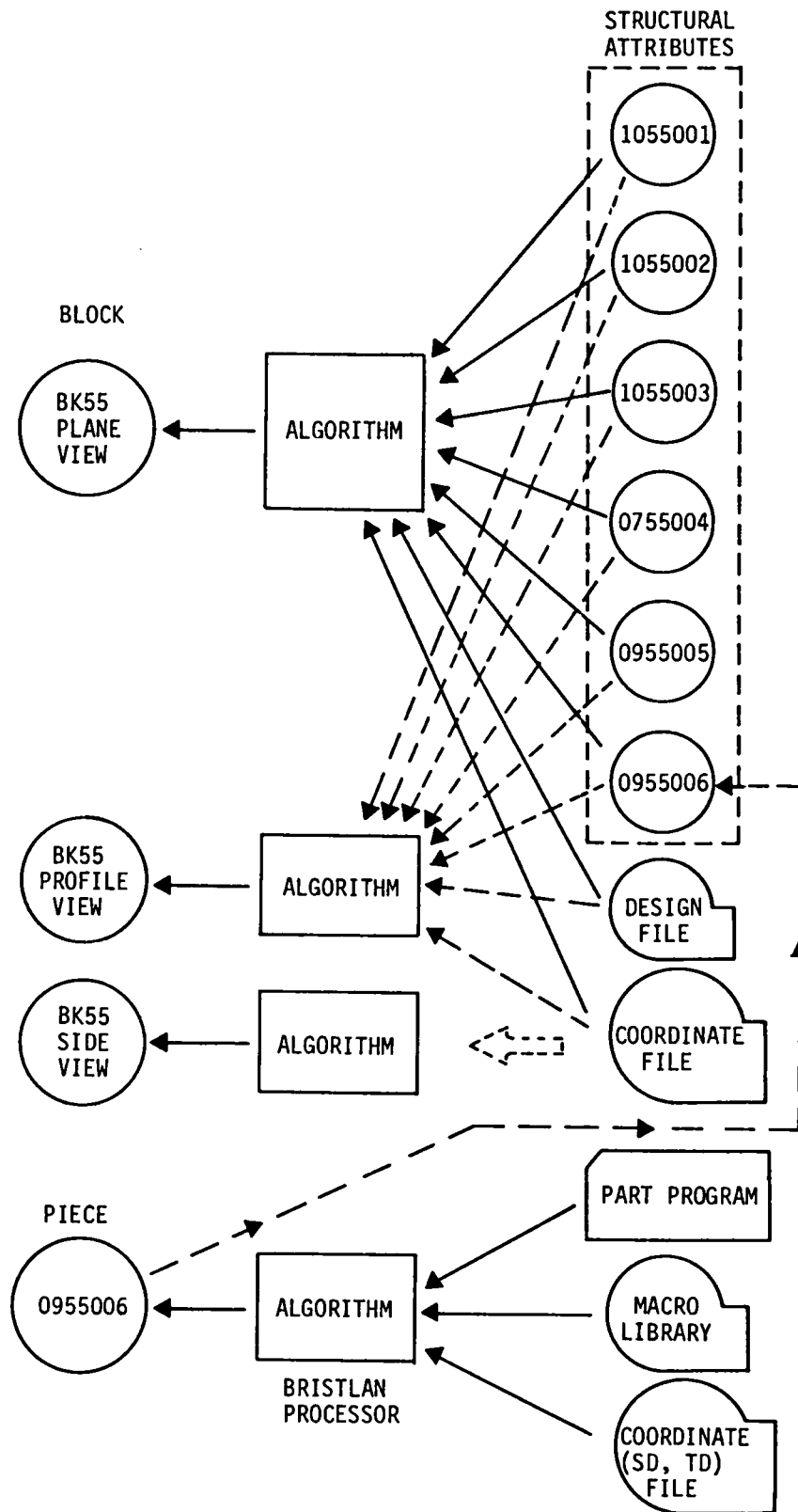

Fig. 3-34 Drawing System Network associated with Blocks and Pieces

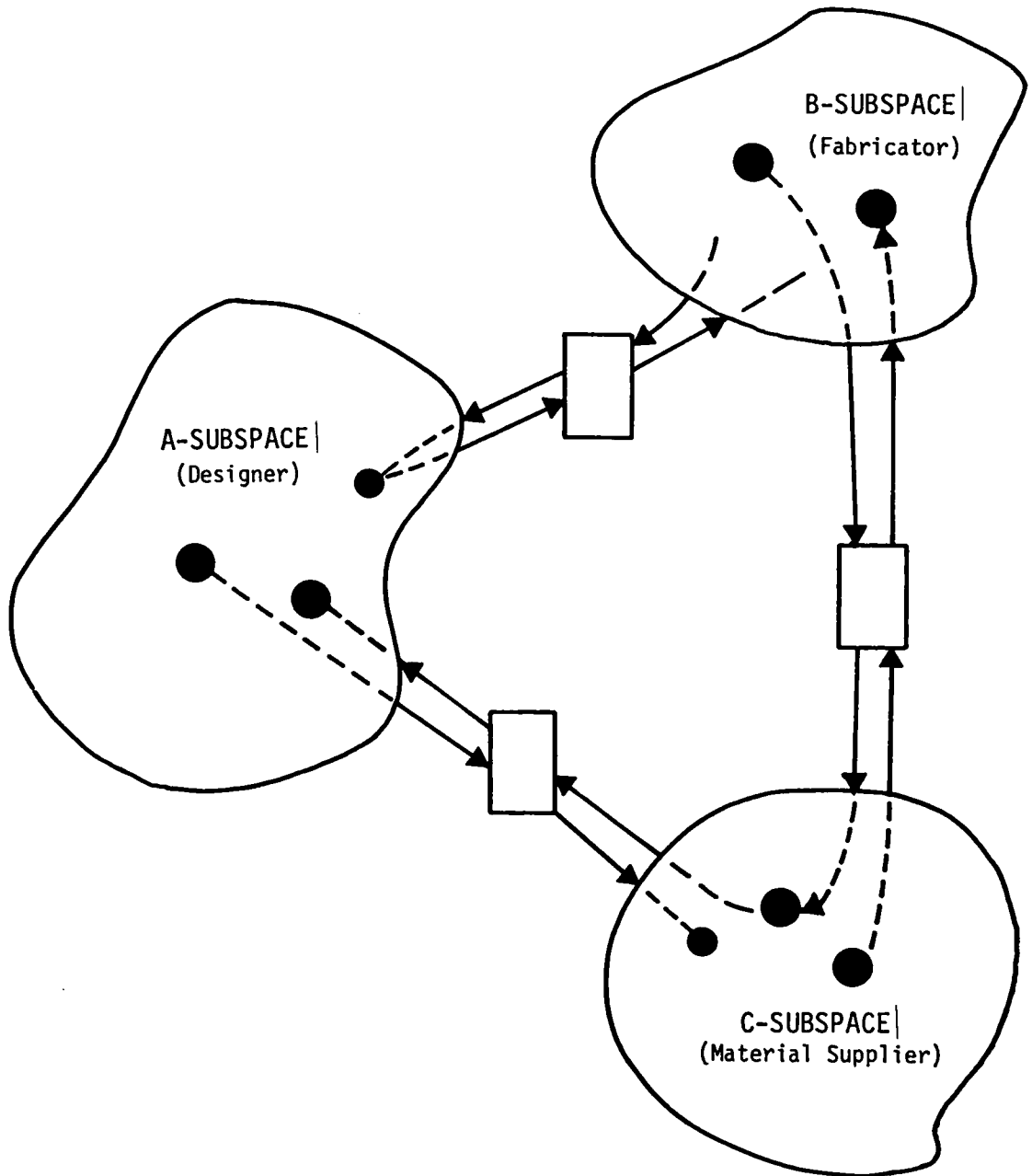

Fig. 3-35 Data Communication among Subspaces

VITA

Tatsumasa Takaku was born on June 11, 1941, in Hoten City, China, and moved to Tochigi in Japan with his family after World War II. He graduated from Kuroiso High School (Tochigi) in March 1960. Beginning in the same year, he attended Kyoto University, where he graduated with a bachelor's degree in Civil Engineering in March 1964 and with a master's degree in the same department in March 1966.

Immediately after graduation, he worked for Nippon Kokan K.K. in Tokyo, where he was engaged in the design and fabrication of steel structures.

In August 1974, he began graduate study at the University of Illinois as a foreign student sent by Nippon Kokan K.K.

In August 1975, he completed a master's degree in Civil Engineering and was then engaged in research for his thesis until June 1976 when he resumed his position with Nippon Kokan K.K.

He is a Member of the Japan Society of Civil Engineers and was formerly a Member of the Optimum Design Group in Kansai Highway Road Research Committee.