

Study on Molecular Structure of Polymethyl Isopropenyl Ketone by X-ray Diffraction Method

Ryuzo KOYAMA*

(Kurata Laboratory)

Received June 5, 1963

The molecular structure and conformation of crystalline polymethyl isopropenyl ketone are studied by X-ray diffraction measurements. The X-ray diffraction patterns of stretched crystalline fibers of the polymer are analysed. The result shows that the structure of the crystal has a tetragonal form with cell dimensions $a=b=15.0 \text{ \AA}$ and $c=8.5 \text{ \AA}$. Our discussion concludes that the molecular chain has the isotactic structure, and that it has a four fold helical conformation with a repeating period of 8.5 \AA .

I. INTRODUCTION

Recently it has been reported¹⁾ that some types of Grignard reagent catalysts are effective to produce highly crystallizable polymers of isopropenyl methyl ketone. That is, the polymer produced with benzoyl peroxide at 60°C was not crystallizable, but the polymers prepared with some of the Grignard reagent catalysts were crystallizable. They give the three types of the X-ray powder spectra: A, B, and C, shown in Fig. 1. The conditions of polymerization and the types of

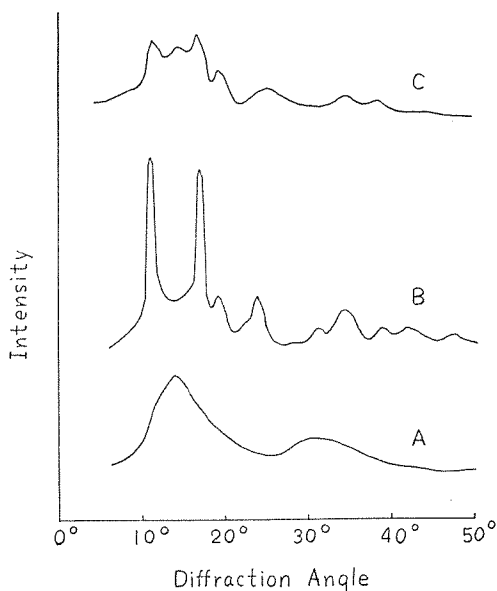

Fig. 1. X-ray powder spectra ($\text{CuK}\alpha$).

* 小山隆三

Table 1¹⁾. Polymerization of isopropenyl methyl ketone.

Catalyst	Solvent	Temp., C°	Time, hrs.	Conversion %	Polymer type
C ₆ H ₅ MgI ^{a)}	Ethylene chloride	-40	5	26.31	B
"	"	-20	5	30.18	B
"	"	+18	5	24.97	B
"	Chloroform	-40	20	41.95	B
"	Toluene	-40	5	8.63	A
C ₆ H ₅ MgI ^{b)}	Ethylene chloride	-40	20	26.76	C
(CH ₃) ₂ CH-MgBr ^{b)}	Tetrahydrofuran	-40	4	17.02	C

a) Toluene solution.

b) Ether solution.

X-ray powder spectrum are summarized in Table 1. The type C polymer could be separated into the types A and B polymers by hot acetone, which are respectively soluble and insoluble in it. The intensities of the X-ray diffraction spectra of types B and C polymers were increased by means of heat treatments at 140-180°C in air and this fact shows the increase in crystallinity in heating. The X-ray photograph of a pressed sample of type B polymer is shown in Fig. 2.

Some physical and chemical properties of these polymers are given in the previous paper¹⁾.

II. EXPERIMENTAL METHOD

The polymer used in this experiment was polymerized in a solvent of ethylene chloride at -50°C with phenyl magnesium iodide as catalyst.

In order to determine the structure of the crystal, uniaxially oriented crystalline samples were obtained through the following procedures. The polymer being well soluble in chloroform, a small quantity of concentrated chloroform solution was poured out upon a flat glass plate and was evaporated in air to produce films of the polymer. By using an appropriate apparatus the film was slowly stretched in one direction in a water bath of 70°C by about ten times of the original length. Then the stretched fiber, just as it was held in the apparatus, was dipped into silicone oil at 140°C during a few seconds. Thus, uniaxially oriented fibrous samples were obtained. The last procedure seems to be effective to increase the crystallinity of the samples through the annealing.

Throughout the X-ray measurement, nickel-filtered Cu K α radiation was used. The diffraction patterns of the fiber by a cylindrical camera are shown in Figs. 3 and 4. In Figs. 3 and 4. the directions of the fiber axes are respectively vertical and horizontal. The diffraction patterns were analysed, and many reflection planes were assigned to the observed diffraction spots as shown in Table 2.

During the experiment of the pattern in Fig. 4 the axis of the fiber was fixed in a position oriented by an angle $\alpha=69^\circ$ to the incident X-ray beam in a horizontal plane. This pattern was taken to observe the strong (004) reflection which can be noticed at the left of Fig. 4, but could not be recognized in the case of

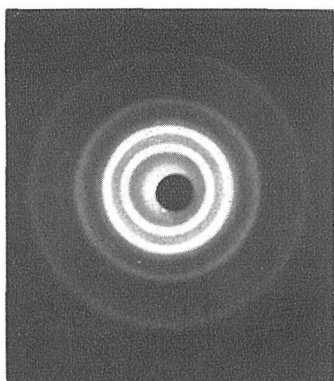

Fig. 2.

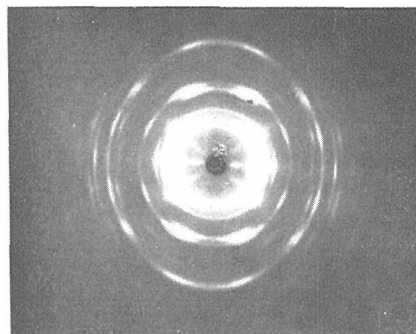

Fig. 3.

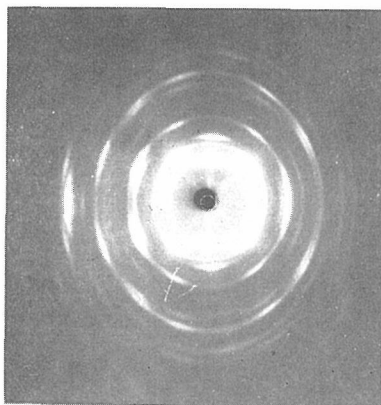

Fig. 4.

normal incidence of X-ray as in the case of Fig. 3. The angle α was determined by the Bragg's condition :

$$2 \sin (\theta_{004}/2) = \lambda/d_{004},$$

and by a relation :

$$\alpha = 90^\circ - \theta_{004}$$

where $\lambda = 1.505 \text{ \AA}$ is the wave length of X-ray, and θ_{004} and d_{004} are the diffraction angle and the distance of (004) reflection plane respectively.

III. RESULT AND DISCUSSION

As seen in Table 2 our result shows that the structure of the crystal of this polymer has a tetragonal form with cell dimensions $a = b = 15.0 \text{ \AA}$ and $c = 8.5 \text{ \AA}$.

According to several reports on polymer crystals, some typical isotactic polymers of similar vinyl type structures can form crystals of tetragonal lattices, and their molecular chains in the crystals have nearly four-fold helical configurations²⁾. For example²⁾, Poly-*o*-methylstyrene ($a = b = 19.01 \text{ \AA}$, $c = 8.10 \text{ \AA}$, 4_1 -helix), Poly- α -vinyl-naphthalene ($a = b = 21.20 \text{ \AA}$, $c = 8.10 \text{ \AA}$, 4_1 -helix), Polyvinyl cyclohexane ($a = b = 21.76 \text{ \AA}$,

Table 2. Results of analysis of X-ray diffraction patterns.

Index (hkl)	Diffraction angle θ_{hkl}	d_{hkl}	Relative intensity
200 020	5° 51'	7.5Å	S
220	8° 18'	5.3	W
310 130	9° 20'	4.7	S
400 040	11° 52'	3.7	W
420 240	13° 16'	3.3	M
510 150	15° 9'	2.9	M
440	16° 55'	2.5	W
620 260	18° 57'	2.3	S
640 460	21° 37'	2.0	W
121 211	8° 25'	5.3	S
112	11° 17'	3.9	S
202 022	12° 2'	3.7	S
231 321	12° 2'	3.7	M
132 312	14° 0'	3.2	W
341 431	15° 48'	2.8	W
402 042	16° 30'	2.7	W
123 213	17° 0'	2.6	M
242 422	17° 0'	2.6	W
251 521	17° 0'	2.6	W
361 631	20° 0'	2.25	W
004	21° 17'	2.12	S

$c = 6.50\text{Å}$, 4_1 -helix), Poly-4-methylpentene-1 ($a = b = 18.60\text{Å}$, $c = 13.85\text{Å}$, 7_2 -helix), Poly-4-methylhexene-1 ($a = b = 19.64\text{Å}$, $c = 14.00\text{Å}$, 7_2 -helix) etc.

Comparing these with our result of analysis, we can consider that the molecular chain of the present polymer has the isotactic structure, and also judging from the extinction rule of the diffraction spots, appearing in Table 2. we can suppose that the molecular chain has a four-fold helical conformation in the crystal, without carrying out any further analysis. With this supposition, the repeating period of the helical chain becomes equal to $c = 8.5\text{Å}$.

In this connection, when we assume that a unit cell of the crystal contains sixteen monomeric units of which each four unit belong to one molecular chain, the crystal density can be calculated to be 1.166, and this is a reasonable value

Table 3.²⁾ Physical properties of types A and B polymers.

Polymer type	Softening point, °C.	Melting point, °C.	Density
A	60 ^{a)}	—	1.11—1.15 (20°C)
	80 ^{b)}		1.12 (25°C)
B	114 ^{b)}	240 ^{c)}	1.15 (25°C)

a) Schildknecht, C. E., "Vinyl and Related Polymers", Wiley, New York, 1952.

b) Dilatometric method.

c) Optical microscopy method.

Molecular Structure of Polymethyl Isopropenyl Ketone

as compared with that of 1.15 which was obtained by the actual measurement for the original bulk polymer¹⁾ (see Table 3 and Fig. 5). This fact is a support to the above conclusions.

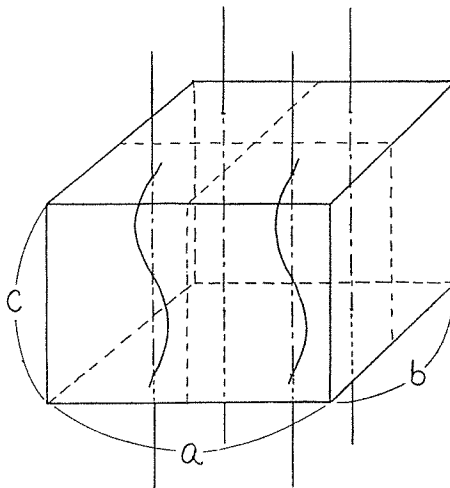

Fig. 5. Unit cell of the crystal.

Recently, R. Fujio and others³⁾ obtained the same kinds of crystalline polymers by anionic polymerization with CaZnEt_2 and other several types of initiators. The polymers give similar X-ray powder spectra to ours, but their molecular and crystal structures were not analyzed.

REFERENCES

- (1) H. Watanabe, R. Koyama, H. Nagai and A. Nishioka, *J. Polymer Sci.*, **62**, S74 (1962).
- (2) G. Natta, *Makromol. Chem.*, **35**, 94 (1960); G. Natta et al, *Nuovo Cimento*, **15**, Serie 10, No. 1 (1960); F.G. Frank, A. Keller and A. O'Conner, *Phil. Mag.*, **4**, 200 (1959); I. Nitta, Y. Chatani and Y. Sakata, *Bull. Chem. Soc. Japan*, **33**, 125 (1960); Y. Chatani, *J. Polymer Sci.* **47**, 491 (1960), etc.
- (3) R. Fujio, T. Tsuruta and J. Furukawa, *J. Chem. Soc. Japan (Ind. Chem. Sec.)*, **66**, 365 (1963).