

## Properties of a Windowless Gas-Flow G-M Counter for TSEE

Tsuneto NAGATOMO and Toshiharu FUJIBAYASHI\*

Received December 25, 1976

A windowless gas-flow G-M counter with an internal sample holder was newly designed for detection of TSEE. Properties of the counter were studied for various temperatures of the sample holder and for gas-flow rates. The plateau region of the characteristic curve remarkably shifts to the lower side of anode voltage for higher temperatures of the sample holder and for smaller gas-flow rates. The counting rate of the detector for a fixed anode voltage depends to the temperature of the gas in the sensitive volume.

### I. INTRODUCTION

Since the energy of Exoelectron leaving the surface of solids is very low, the available techniques for detecting Exoelectrons have been restricted. For investigations of Thermally Stimulated Exoelectron Emission (TSEE) or Exoelectron Dosimetry (TED), the windowless gas-flow counters are used in the GM or proportional region. The characteristics of this type of detectors have been studied by several workers.<sup>1)</sup> However, no detailed investigations on the thermal properties of gas counters for TSEE have been reported, although there are some studies on the characteristics of proportional counters at fixed temperatures up to 900°C.<sup>2)</sup> When the temperature of the internal sample holder of a gas counter is raised continuously, the electrical response of the counter may be changed. Therefore, for the reliable performance of experiments on TSEE or TED, it must be worthwhile to study the thermal properties of windowless gas-flow counters for temperature variation of the internal sample holder.

A gas-flow G-M counter with an internal sample holder, of which temperature can be continuously changed from room temperature up to about 500°C, was newly designed. In this paper, are reported the properties of this counter as functions of the temperature of sample holder,  $T_s$ , and of the gas-flow rate,  $Gr$ .

### II. COUNTER DESIGN

The construction of the G-M counter is shown in Fig. 1. The temperature of the internal sample holder of copper with a superficial hollow of 11 mm in diameter can be changed from room temperature up to 500°C by a seath heater. The sensitive volume ( $20 \times 50 \times 20 \text{ mm}^3$ ) was constituted by 0.7-mm thick epoxy-glass plate coated with 0.07-mm thick copper in the main construction of the counter ( $50 \times 88 \times 20 \text{ mm}^3$ ) made by brass. In spite of the rather small sensitive volume, the dual

\* 長友恒人, 藤村敏治: Department of Physics, Nara University of Education, Nara.

Properties of a Windowless Gas-Glow G-M Counter for TSEE

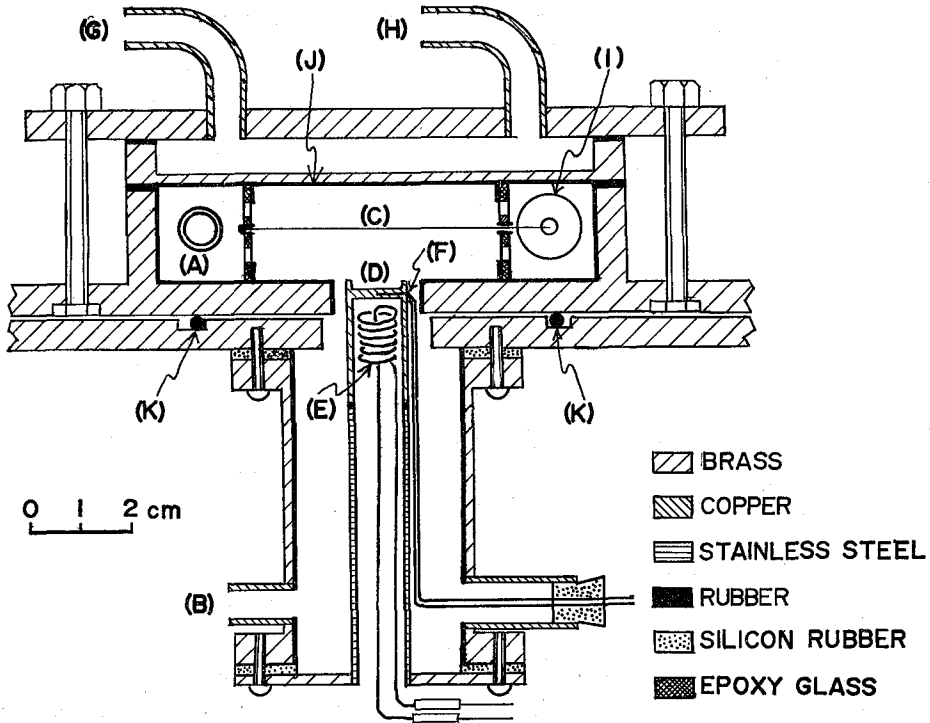

Fig. 1. Construction of G-M counter; (A) gas inlet, (B) gas outlet, (C) anode wire, (D) sample holder, (E) heater, (F) thermocouple, (G) waterinlet, (H) water outlet, (I) insulator, (J) nickel-plated cathode, (K) O ring.

composition should be effective for stable operations of the counter, when the temperature of the sample changes rapidly. Taking into consideration the thermoionic electron emission from the wall surface at high temperature, the inner surface of the sensitive volume was plated by nickel (work function=0.5 ev). The top of the sensitive volume is cooled so that the gas temperature is not rapidly raised when the sample is heated. A tungsten wire of 50-mm length and 40  $\mu\text{m}$  in diameter was used as an anode.

The output pulses from the anode were transferred to a rate meter through an amplifier and a discriminator set at 30 mV, and then were recorded by a two pen recorder. The temperature of the sample holder measured by a copper-constantan thermocouple was also recorded by the recorder.

III. CHARACTERISTICS OF THE COUNTER

Using a point source of  $^{22}\text{Na}$  (0.01  $\mu\text{Ci}$ ) placed on the outside wall of the counter, the characteristics of the G-M counter were tested for various temperatures of the sample holder and for the flow rates of the gas (96 % He and 4 %  $\text{C}_4\text{H}_{10}$ ). The pulse height of the counter operated at applied voltage of 1100 V changed from 0.9 to 2.5 volt corresponding to the  $T_s$  range from room temperature to 450°C. The dead time of the counter is about  $6 \times 10^{-5}$  sec (which is somewhat shorter compared with the typical dead time of  $10^{-4}$  sec<sup>4)</sup>), and the value is not so much affected by

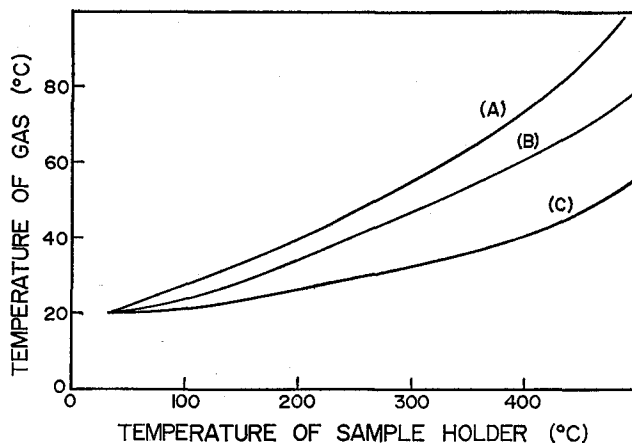

Fig. 2. Temperature of the gas at the center of the sensitive volume versus temperature of the sample holder.

the change of  $Gr$  and  $T_s$ .

In Fig. 2, the gas temperature,  $T_g$ , in the sensitive volume is illustrated as a function of  $T_s$  for constant  $Gr$  of 20, 40, and 100 ml/min. The measurements were performed in such a way that one thermocouple was set to the sample holder and the other was inserted into the sensitive region after removing the anode wire. The value of  $T_g$  for  $Gr=20$  ml/min is about twice of that for  $Gr=100$  ml/min. This circumstance is certified by the measurement at several points in the sensitive region.

The characteristic curves of the counter, counting rate versus applied voltage, were obtained for various values of  $T_s$  and  $Gr$ . The slope of the plateau is larger for higher temperature of the sample holder, that is, 2.0, and 3.3 cpm/volt at  $T_s=20$  and 400°C for  $Gr=50$  ml/min, respectively. As to the curve obtained for  $Gr=20$ , 50, and 100 ml/min and at  $T_s=300$ °C, the plateau slope is 5.3, 2.6, and 2.4 cpm/volt, respectively. The plateau regions of the curves are shown in Fig. 3 for  $Gr=50$  ml/min. The figure indicates that both of lower and upper limits of the plateau region decrease and the plateau range becomes short as  $T_s$  increases. The plateau region for  $Gr=20$  and 100 ml/min measured at  $T_s=20$  and 300°C are also shown in the figure. Although the lower limit of the plateau region does not depend appreciably on  $Gr$ , the upper limit does remarkably. These situations seem to be attributed to the strong dependence of the discharge in the sensitive volume to the gas temperature, referring Fig. 1.

The counting rate versus  $T_s$ , which is shown in Fig. 4, was measured at the constant value of anode voltage, 1100 V, for  $Gr=20$ , 50, and 100 ml/min. The figure indicates that the counting rate depends on  $Gr$  and  $T_s$  as well as the other factors such as gas, geometry of the sensitive volume, and materials of anode and cathode. In the present case, the counting rate is constant for  $T_s$ =room temperature up to about 220°C, which corresponds to  $T_g$ =room temperature up to about 40°C, for all  $Gr$ 's. When  $T_s=400$ °C, the counting rates for  $Gr=20$ , 50, and 100 ml/min are respectively 225, 118, and 112 % of the rate for  $T_s<220$ °C. The increase in the

Properties of a Windowless Gas-Glow G-M Counter for TSEE

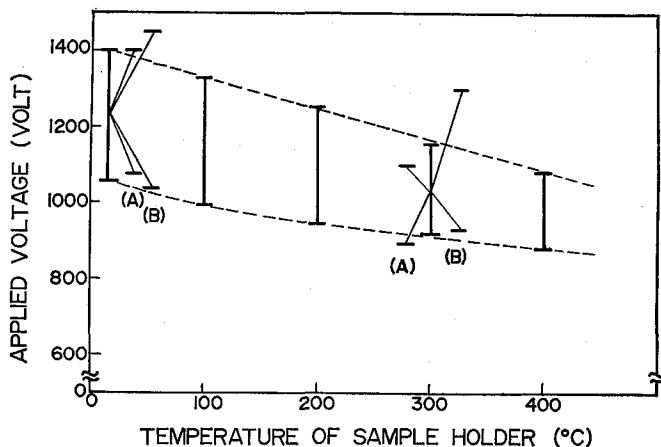

Fig. 3. Plateau range of characteristic curve of the counter *versus* temperature of the sample holder for gas-flow rate,  $Gr=50$  ml/min. (A) and (B) indicate the plateau ranges for  $Gr=20, 100$  ml/min, respectively.

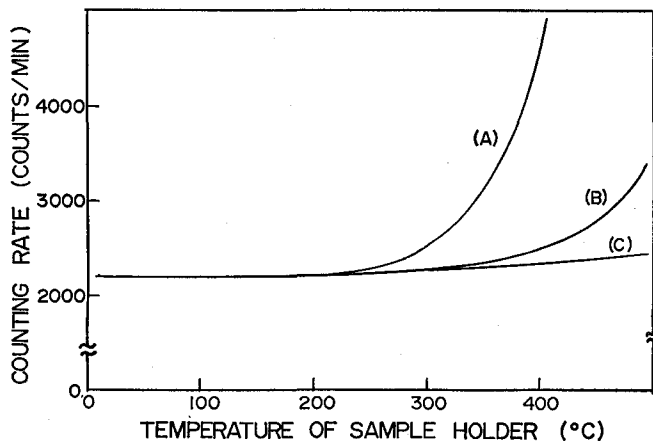

Fig. 4. Counting rate *versus* temperature of the sample holder (anode voltage is 1100 volt); (A) for gas-flow rate,  $Gr=20$  ml/min, (B) for  $Gr=50$  ml/min, (C) for  $Gr=100$  ml/min.

counting rate may be explained by the shift of the gas discharge region due to the change of  $T_g$ .

Since the studies on TSEE are usually performed by analyzing the glow curves of samples, the thermal properties of the detectors, in particular the dependence of the counting rate on  $T_s$ , should be taken into consideration. It should also be noted that there might be any disturbance to the shape of glow peaks due to the change of gas temperature in the counter.

**ACKNOWLEDGMENT**

The authors wish to express their thanks to Mr. F. Kawai for his kind help in constructing the counter.

**REFERENCES**

- (1) See, *e.g.*, K. Becker, *Proceed. of 4th Internat. Symp. on Exoelectron Emission and Dosimetry, Czechoslovakia, Feb. 1973*, pp. 218; W. Rasp and V. Siegel, *Proceed. of 4th Internat. Conf. on Luminescence Dosimetry, Kraków-Poland, Aug. 1974*, **2**, pp. 759.
- (2) A. Moljk, R. W. P. Drever, and S. C. Curran, *Rev. Sci. Instr.*, **26**, 1034 (1955).
- (3) William J. Price, "Nuclear Radiation Detection," McGraw-Hill New York, Toront and London (1958), p. 115.