

Design of 433.3-MHz Proton RFQ Linac

H. OKAMOTO*, K. FUKUNAGA*, Y. IWASHITA*, M. SAWAMURA*,
M. INOUE* and H. TAKEKOSHI*

Received January 31, 1987

A 2-MeV proton radio-frequency quadrupole (RFQ) linac whose operating frequency is two times higher than that of the conventional proton linacs has been designed as a first stage of a 7-MeV linac for multi-disciplinary use. The design value is 50 mA as output peak current. The cavity which has four vanes is made of CrCu. The inner diameter and the cavity length are 170.4 mm and 2195 mm respectively. The vane is cut by a special cutter which is two dimensionally moved to reduce the machining cost. The electric field was calculated as a two dimensional electrostatic boundary problem by boundary element method. The temperature distribution of the vane has also been estimated by boundary element method.

KEY WORDS: RFQ linac/ Proton linac/

1. INTRODUCTION

At the Facility of Nuclear Science Research, Institute for Chemical Research, Kyoto University, a 7-MeV proton linear accelerator is now under construction.^{1),2),3)} This linac is composed of a 2-MeV 4-vane RFQ⁴⁾ linac and an Alvarez drift tube linac (DTL). In order to reduce the size of the linac the operating frequency has been chosen at 433.3 MHz which is about two times higher than that of recent proton linacs. The RFQ linac, called POP (proof-of-principle),⁵⁾ was constructed to verify the principle of radio frequency quadrupole at Los Alamos National Laboratory in 1980 and its resonator had 1.1-m-long vanes and a 0.15-m outer diameter. The RF power of POP was fed by a 425-MHz klystron that was coupled to the resonator through a coaxial manifold and coupling slots. POP successfully accelerated up to 30-mA protons from 100 to 640 keV with high transmission. After POP experiments, longer RFQ linacs were developed in LANL.⁶⁾ But these linacs had some difficulties such as the RF tuning, precise vane positioning and so on. Many of them seem to come from the manifold structure and its length.

The RFQ linac of Kyoto University is a first stage of the 7-MeV linac which will be routinely used for multi-purpose. Our RFQ linac has no RF manifold and RF power is supplied by a loop coupler. Many sensors and tuners are also mountable. Inductive tuners are adopted as end tuners. Vane coupling rings are not mounted. The general view of the RFQ cavity is shown in Fig. 1. In this paper the design characteristics of our RFQ linac is reported. The searching process of the fundamental RFQ parameters are described in §2, and the two dimensional cutting process of the vanes is discussed in §3. In §4 the correction on the vanetip shape for intervane

* 岡本宏己, 福永清二, 岩下芳久, 沢村 勝, 井上 信, 竹腰秀邦: Facility of Nuclear Science Research, Institute for Chemical Research, Kyoto University.

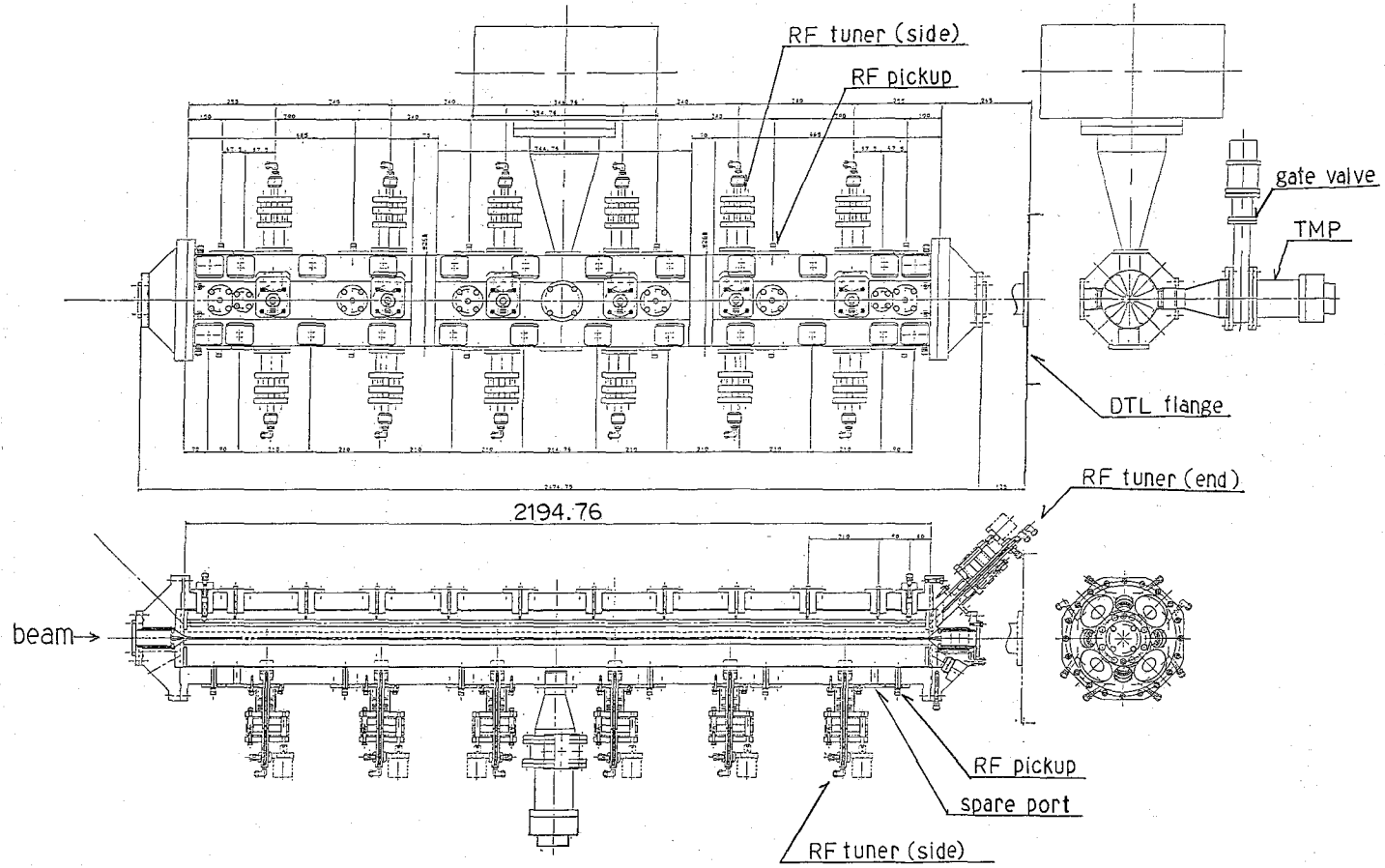

Fig. 1. General view of RFQ linac

capacitance compensation is described, and the vane cooling problem is also discussed in §5.

2. PARAMETER SEARCH

The specification of the fundamental parameters of this RFQ linac are following.

- (1) accelerating particles : H^+ , H^-
- (2) operating frequency : 433.3 MHz
- (3) output energy : 2 MeV
- (4) output current : 50 mA (peak)

In addition to these conditions next two demands have been considered.

(A) : the vane is cut by 2-dimentional process with a concave cutter

(B) : overall length of the cavity is about upto two meters

The demand-(A) comes from simplification of vane cutting and reduction of the machining cost. The demand-(B) is required for easier RF tuning and tank machining.

Generally the RFQ linac has four sections which are usually called radial matching section, shaper section, gentle bunching section and accelerating section. To determine the fundamental parameters in these sections a computer code "PARMTEQ" was used. Before the simulation using this code, the intervane voltage and the average bore radius were determined. In our RFQ linac 80-kV intervane voltage and 2.999-mm average bore radius were taken. Under this condition the focusing strength factor became 4.54 except for the radial matching section and the maximum surface field was 1.8 times as large as the Kilpatrick field limit. In radial matching section, which is ten cells long, the focusing strength varies sinusoidally⁷⁾:

$$B(z) = B_0 \sin(kz) \quad (1)$$

$$(B=4.54, k=\pi/2L, L=\text{total length of radial matching section})$$

The parameters of our RFQ linac were optimized by the following procedure in consideration of (A) and (B): At first the restriction from two dimentional cutting process of the vane was obtained. This restriction is a function of modulation size and cell length. Considering this restriction, modulation parameter and synchronous phase were varied gradually. The fundamental parameters which could achieve the best transmission efficiency were searched by PARMTEQ simulation. In the

Table. 1 Main parameters of RFQ linac

operating frequency (MHz)	433.3
kinetic energy (MeV)	0.05~2.0
vane length (cm)	219.48
cavity diameter (cm)	17.04
characteristic radius (mm)	2.999
min. bore radius (mm)	1.99
max. modulation	1.90
focusing strength	4.54
intervane voltage (kV)	80
transmission efficiency (normalized emittance of input beam : $0.7\pi\text{mm}\cdot\text{mrad}$)	
99% (0mA)	95% (30mA) 88% (60mA)

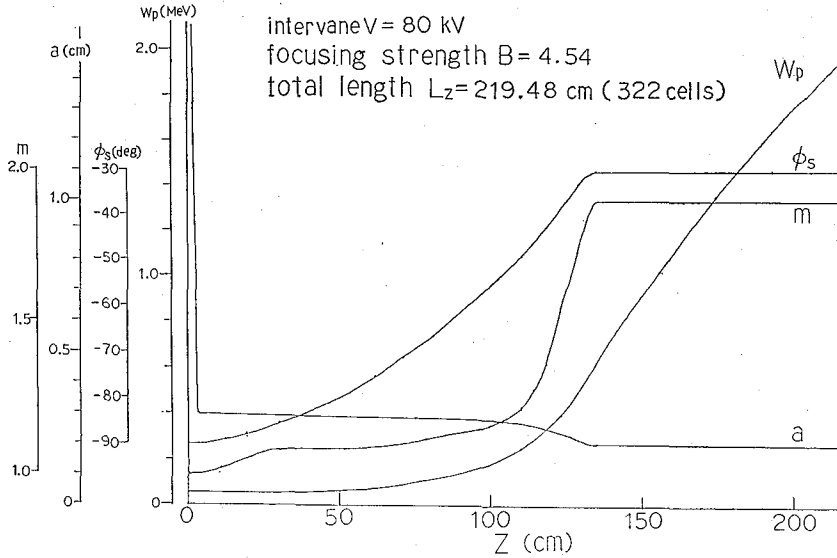

Fig. 2. Longitudinal variations of RFQ design parameters

gentle bunching section the value of RF defocusing strength was taken to be constant except for the latter half. In the accelerating section the modulation parameter is fixed at maximum value and the synchronous phase is also constant. The main parameters obtained by the above simulation process is shown in Fig. 2 and Table 1. The overall length of the vane is 2194.76 mm, which almost satisfies (B). About 60-mA input beam current with the normalized beam emittance of 0.7π mm·mrad is enough for 50-mA output peak current. In the case of 1.4π mm·mrad emittance beam the relation between the input beam current and the transmission efficiency is shown in Fig. 3. This figure shows that the output beam

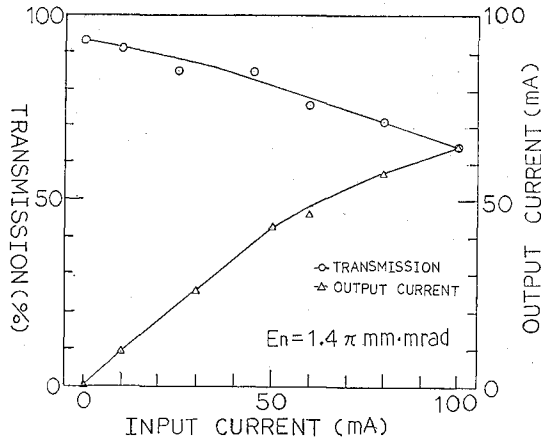

Fig. 3. Input beam current vs. output beam current and transmission efficiency for input beam with normalized emittance of 1.4π mm·mrad

Design of 433.3-MHz Proton RFQ Linac

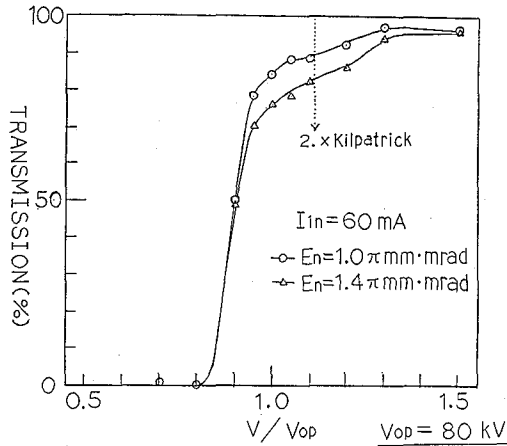

Fig. 4. Transmission efficiency vs. ratio of the operating vane voltage to the optimized one

current of about 50 mA can be obtained at 60-mA input beam even if the input beam emittance becomes two times as large as the designed value. Fig. 4 shows the transmission efficiency as a function of the ratio of the operating intervane voltage to the optimized one.

3. TWO DIMENSIONAL PROCESS FOR THE VANE CUTTING

The transverse curvature of the vanetip is constant because of the two dimensional vane cutting process (Fig. 5). In our design the curvature is equal to the average bore radius r_0 .

The longitudinal vanetip shape was approximated by sinusoidal curve, and the restriction for the vanetip cutting with a given cutter was obtained. Considering this restriction, the optimum modulation parameters were searched. As an example, the vanetip shape of No. 140 cell after cutting with a cutter of 20-mm radius is shown in Fig. 6a. In the upper graph two curves represent the trajectory of a rotating axis of the cutter, and the vertical difference between the ideal vanetip shape (sinusoidal)

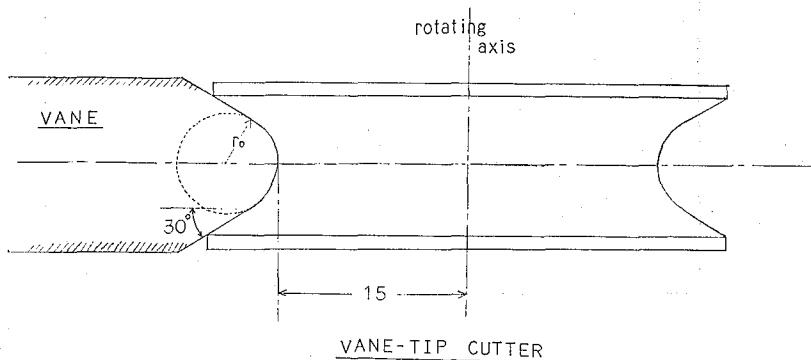
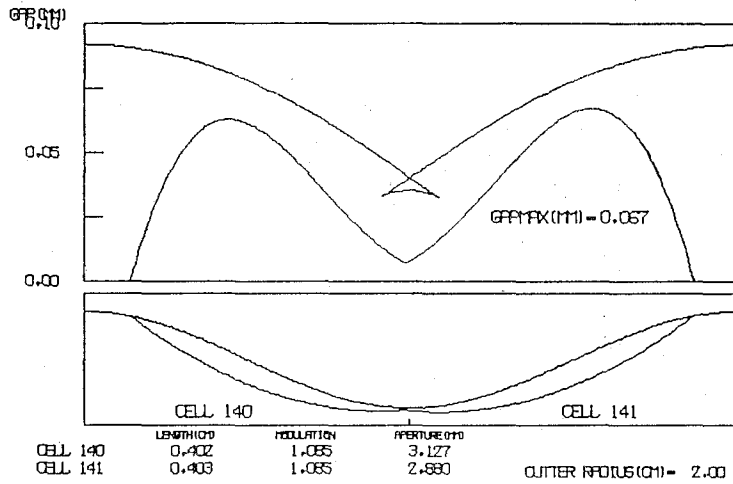
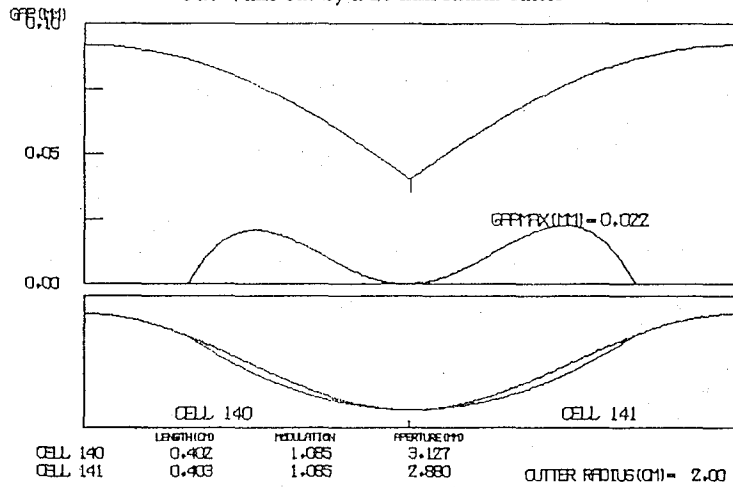

Fig. 5. Vanetip cutter



6 a: Vane cut by a 20-mm radius cutter



6 b: Vane cut by a 20-mm radius cutter in consideration of the correction of a cutter trajectory

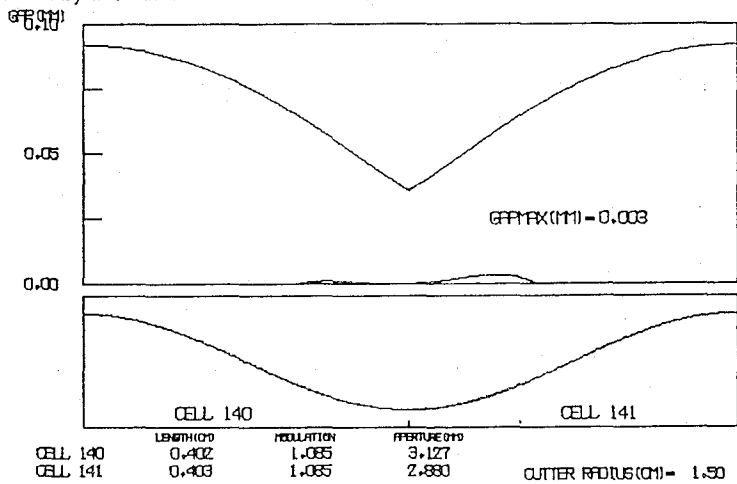

6 c: Vane cut by a 15-mm radius cutter in consideration of the correction of a cutter trajectory

Fig. 6. The shape of No. 140-cell after 2-dimensional cutting

and the machined vanetip shape. Two curves in the lower graph represent the ideal vanetip shape and the machined vanetip shape. The figure shows the excessive cut of the vane due to the reverse movement of the rotating axis of the cutter. This error can be reduced to one-third by the correction of the cutter trajectory (Fig. 6b). Furthermore this cutting error can be reduced to a few micro-meters with a cutter of 15-mm radius (Fig. 6c).

4. CORRECTION OF THE VANETIP SHAPE

In PARMTEQ simulation, the modulation parameter “m” and the minimum bore radius “a” are used independently in each cell, and the bore radii of the adjacent cells are different at the joint. To connect the adjacent cells without this discontinuity the average was taken for the bore radius at the joint, so that the bore radius at the joint of each adjacent cells is uniquely determined and the vanetip shape is made smooth.

In general, the intervane capacitance of the RFQ structure varies longitudinally, so the vane voltage might tilt. In our case the correction of the valley shape for capacitance compensation has been introduced as shown in Fig. 7. According to the following discussion it is also expected to reduce the error of the accelerating field which comes from the two dimensional cutting process.

According to SUPERFISH calculations, the frequency will rise as modulation increases. For example, at modulation parameter of 2 (two opposing vane tops are 2 mm from axis, and another are at 4 mm), the frequency rise is 6.5 MHz. It comes from the capacitance decrease at the vanetip. The electric field was calculated as a two dimensional electrostatic boundary problem by boundary element method. The assumption of two dimensional problem is good when the cell length is large enough compared to the modulation size. The shape of the problem is shown in Fig. 8. Capacitance, potential on axis and multipole components of potential on the circle of

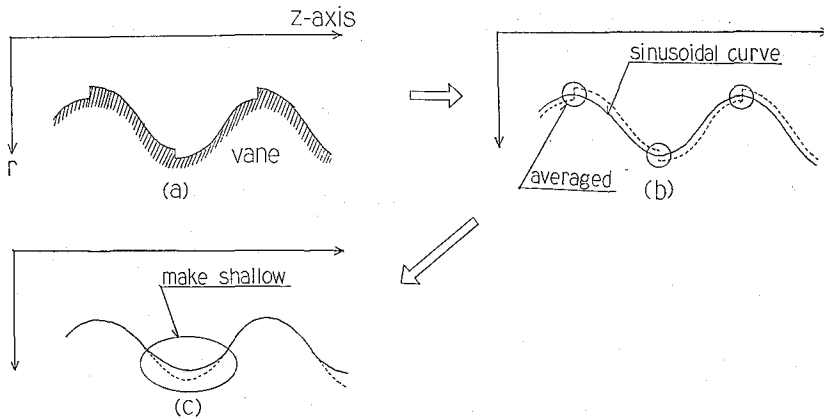

Fig. 7. Correction concept of the modulation shape

- (a): theoretical curve having discontinuity at the cell joint
- (b): approximated curve
- (c): final curve obtained by making the modulation valley shallow

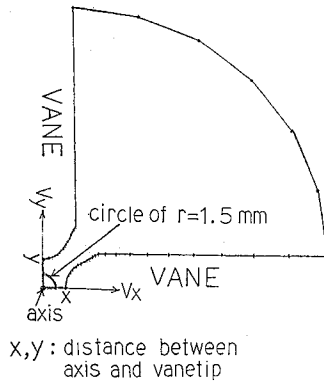

Fig. 8. The shape of a two dimensional electrostatic boundary problem

$r=1.5$ mm were evaluated. Fig. 9a shows the capacitance contour as a function of x and y . The capacitance of $m=1$ ($x=3$ mm, $y=3$ mm) is 32.5 pF/m, and that of $m=2$ ($x=2$ mm, $y=4$ mm) is 31.4 pF/m. The capacitance will be kept constant if the Δx and Δy have following relation;

$$\Delta y = -(\Delta x + \Delta x^2/5) \quad (\text{for } -1 \text{ mm} < \Delta x < 0 \text{ mm}). \quad (2)$$

Fig. 9b shows the potential contour on the axis. For ideal hyperbolic shape vane with long enough cell compared to the modulation size, the accelerating efficiency A is following;

$$A = (m^2 - 1)/(m^2 + 1). \quad (3)$$

The potential at axis is $A \cdot V = 30$ kV for $m=2$ and vane voltage $V=50$ kV. Although the correction (2) overcompensates the potential variation, we made great account of the easy RF tuning. Fig. 9c, 9d and 9e shows the quadrupole, octapole and dodecapole component respectively. Three dimensional calculation will be needed for more accurate consideration.

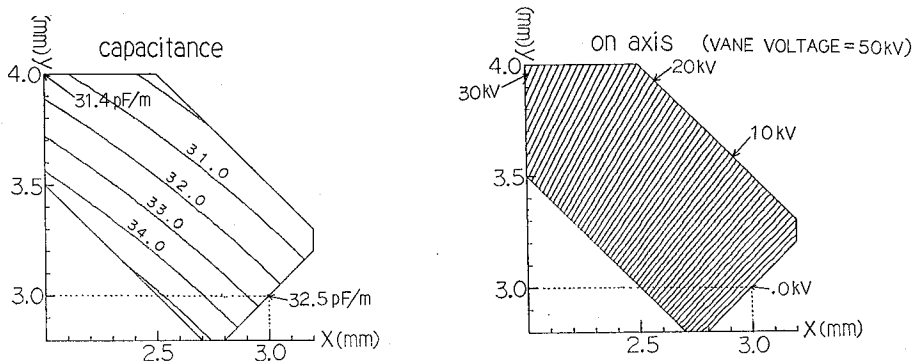
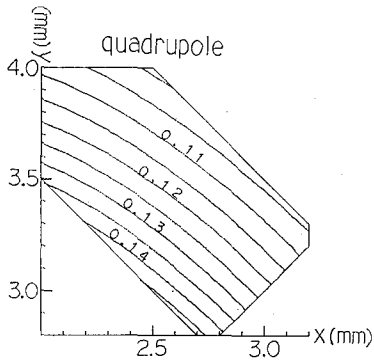

Fig. 9. 9 a: the capacitance contour as a function x and y

9 b: the potential contour on axis

Design of 433.3-MHz Proton RFQ Linac



9 c: the potential contour of quadrupole component

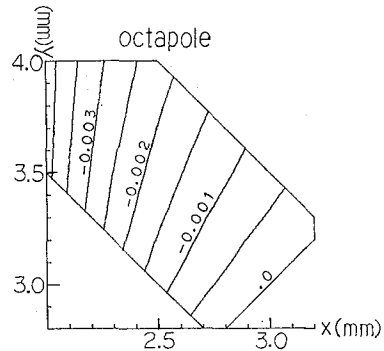

9 d: the potential contour of octapole component

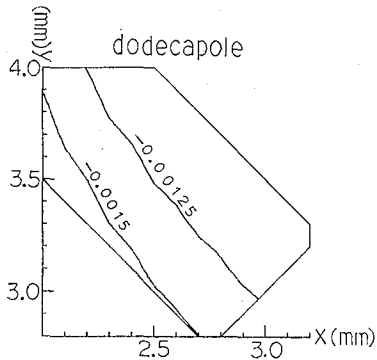

9 e: the potential contour of dodecapole component

5. VANE COOLING

The total peak RF power dissipation is estimated to be about 500 kW by SUPERFISH. About two-thirds of the power is dissipated on the vane wall. A temperature rise of the RFQ vane caused by RF power dissipation was calculated by boundary element method. In this calculation the heat transfer coefficient between cooling water and copper was obtained assuming the turbulent flow by the next equation;

$$\text{Nu} = 0.023 \cdot \text{Re}^{0.8} \cdot \text{Pr}^{0.4} \quad (4)$$

(Nu: Nusselt number, Re: Reynolds number, Pr: Prandtl number)

The 20-mm ϕ cooling passage is located at 50 mm from the cavity axis. The temperature distribution on the vane surface is shown in Fig. 10 when 30°C water is flowing at a speed of four meters per second. Fig. 10a and Fig. 10b correspond to the vane voltage of 40 kV and 50 kV respectively. The difference of the temperature on the vane surface is small enough.

6. CONCLUDING REMARKS

The operating frequency of our RFQ is so high and its size is so small that many

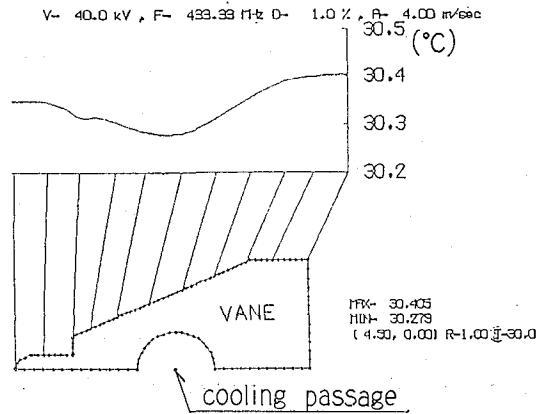

10 a: vane voltage of 40 kV

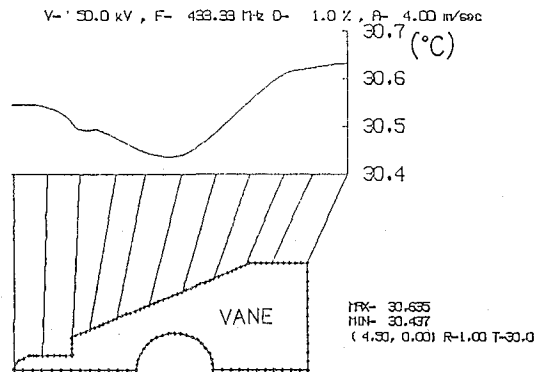

10 b: vane voltage of 50 kV

Fig. 10. Temperature distribution of vane cooled by single cooling passage of 20-mm diameter

difficulties, especially mechanical one, exist. For example, this machine could be very sensitive to the vane misalignments.

Our RFQ linac has many experimental features such as the correction of the vanetip shape, the inductive end tuners, 2-dimensional cutting of the vanes and so on. These unique features will be evaluated by experiments and the results will be reported in a next paper.

REFERENCES

- 1) H. Okamoto et al.: "Design of Proton RFQ Linac", Proc. of the 11th Meeting on Linear Accel., KEK, JAPAN (1986).
- 2) M. Sawamura et al.: "Alvarez Linac with Post Couplers", Proc. of the 10th Meeting on Linear Accel., JAPAN (1985).
- 3) H. Okamoto and Y. Iwashita: "Study of Permanent Magnet Quadrupole Lens for Proton Linac", Bull. Inst. Chem. Res. Kyoto Univ. Vol. 64, No. 1 (1986).
- 4) I.M. Kapchinskii and V.A. Teplyakov: "Linear Ion Accelerator with Spatially Homogeneous Strong Focusing", Prib. Tekh. Eksp. 119, No. 2, p. 19 (1970).
- 5) J.E. Stovall et al.: "Performance Characteristics of a 425-MHz RFQ Linac", Proc. 6th Conf. on

Design of 433.3-MHz Proton RFQ Linac

Applications of Accelerators in Research and Industry, Denton, Texas, November 3-5, 1980
IEEE Trans. Nucl. Sci. 28, p. 1508 (1981).

- 6) F.O. Purser et al.: "Operating Characteristics of a 2.0-MeV RFQ", IEEE Trans. Nucl. Sci., Vol. NS-30, No. 4, August (1983).
- 7) N. Tokuda and S. Yamada: "New Formulation of the RFQ Radial Matching Section", Proc. of the 1981 Linear Accel. Conf., p. 313 (1981).