

## Decoration of Polyethylene Single Crystals with Poly(3-hexylthiophene) Whiskers

Kyo Jin IHN\* and Paul SMITH\*

*Received June 19, 1991*

Polyethylene single crystals were decorated with poly(3-hexylthiophene) whiskers grown from a solution. Transmission electron microscopy revealed that the poly(3-hexylthiophene) whiskers were preferentially oriented normal to the {110} growth faces of the polyethylene single crystals. By contrast, the whiskers grown onto the fold surface of the polyethylene single crystal were randomly distributed. A possible orientation of the poly(3-hexylthiophene) molecules onto the {110} growth faces of the polyethylene single crystal is proposed.

KEY WORDS: Electron microscopy / Epitaxy / Morphology / Whisker / Decoration / Polyethylene / Poly(3-hexylthiophene)

### INTRODUCTION

Polyethylene (PE) single crystals grown from dilute solutions typically have lamellar morphologies of a thickness of approximately ten nanometers. In these platelet-type crystals the macromolecular chains are folded, and packed with their molecular axis normal to the lamellar plane.<sup>1,2</sup> Evidence for chain-folding in PE single crystals was first observed in transmission electron microscopic studies (TEM) and was reported by Keller in 1957.<sup>3</sup> Extensive studies since have been carried out to examine the detailed structure of the folded chain crystals.<sup>4-10</sup>

Deposition of crystallizable materials onto PE single crystals has been employed to reveal the surface morphology of the lamellae. Several materials have been utilized for this purpose, such as gold<sup>11</sup> and various polymers<sup>12,13</sup>. A particularly interesting and useful decoration method was introduced by Wittmann and Lotz<sup>12,13</sup>. These authors evaporated PE in vacuum onto PE single crystals. They observed growth of rod-like crystals of the evaporated PE, which were aligned normal to the growth face of PE single crystals. Electron diffraction experiment revealed that the vapor-deposited PE molecules oriented parallel to the {110} growth faces of the PE single crystals. It was concluded from these results that the structure of the fold surface of PE single crystals may be rather regular.

In this study we report on decoration of PE single crystals with poly(3-hexylthiophene) (P3HT) whiskers, which were grown from solution. We observed that the latter fibrillar entities grew epitaxially, unlike the above rod-like PE crystals, normal to {110} growth planes of the PE single crystals.

In a previous paper<sup>14</sup> on the crystallization behavior of P3HT we demonstrated that this interesting conjugated, conducting polymer may grow from solution in the

---

\* 印教員, Paul Smith: Materials Department and Department of Chemical & Nuclear Engineering, University of California at Santa Barbara, CA 93106, USA

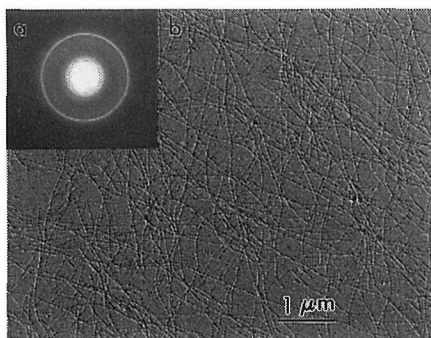

Fig. 1 TEM image of P3HT whiskers (b) and electron diffraction pattern (a). The whiskers were grown from a 0.05 wt % P3HT/cyclohexanone solution. Shaded with Pt in order to increase contrast.

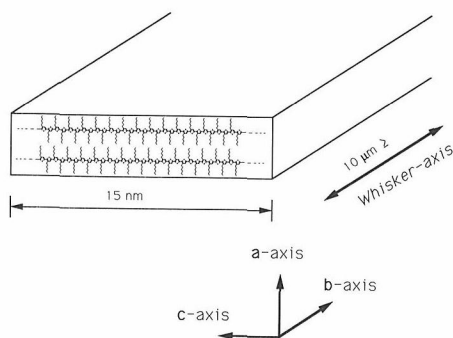

Fig. 2 Schematic drawing of packing of P3HT molecules in the whiskers. The picture shows that the whisker axis is parallel to the *b*-axis of P3HT, and that the P3HT macromolecules are stacked normal to the whisker axis.

form of whisker-like single crystals. The as-grown P3HT whiskers have a ribbon-like morphology, as shown in Figure 1. The average length of the crystals typically exceeded  $10\ \mu\text{m}$ ; the thickness and width were approximately 4 and 15 nm, respectively. Wide-angle X-ray and electron diffraction studies revealed that the P3HT chain molecules were aligned perpendicular to the long whisker-axis. Because the length of the P3HT macromolecules was several times larger than the width of the whiskers, it was concluded that the macromolecules must fold back on the long edge of the crystals. Transmission electron microscopic studies and small-angle X-ray diffraction experiments revealed that the thickness of the whiskers ( $\sim 4\ \text{nm}$ ) was rather regular and corresponded often to two or occasionally three molecular layers, only. Figure 2 shows the proposed molecular orientation in the P3HT whiskers. As is illustrated in this picture, the whisker direction is parallel to *b*-axis, along which the heterocyclic  $\pi$ -bonds are stacked side by side. The same whisker morphologies were found also for other poly(3-alkylthiophenes), such as poly(3-butylthiophene), poly(3-octylthiophene) and poly(3-dodecylthiophene)<sup>14</sup>.

## EXPERIMENTAL

Single crystals of PE of  $M_w = 60,000$  (Alathon, Du Pont) were grown at  $80^\circ\text{C}$  from a 0.01 wt % xylene solution. The PE single crystals were placed onto a Cu grid coated with carbon film for observation in the transmission electron microscope.

The mounted PE single crystals were placed in a 0.05 wt % solution of P3HT ( $M_w = 120,000$ , courtesy of J. Moulton) in cyclohexanone at  $50^\circ\text{C}$ , which is below the dissolution temperature of PE. Subsequently, the P3HT solution was cooled down to room temperature, and the conjugated polymer crystallized in the form of the whiskers described above. P3HT whiskers were found both in the solvent and on the surface of the PE single crystals. The Cu grid with the polymer crystals was rinsed several times with pure cyclohexanone in order to remove the whiskers floating in the suspension. The P3HT-decorated PE crystals were examined by TEM (JEOL 100CX) operated at

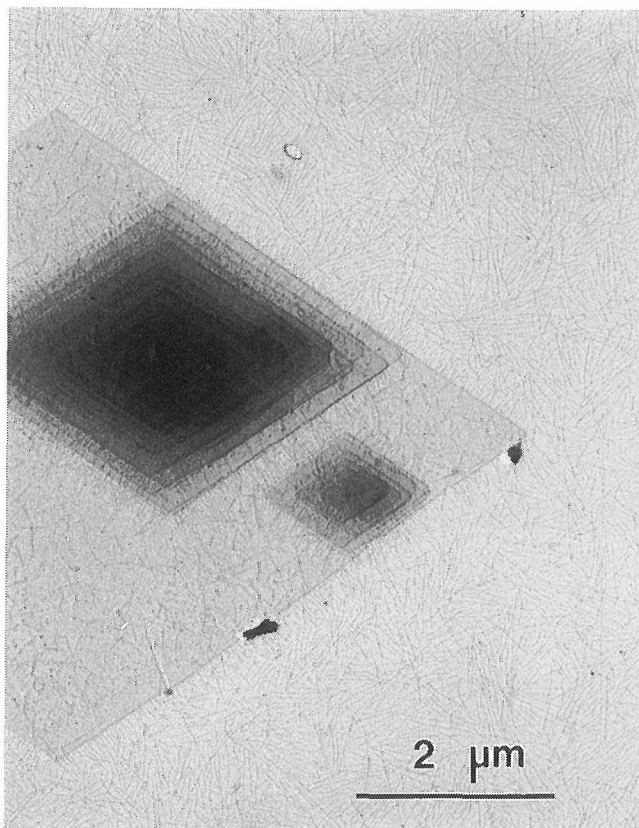

Fig. 3  
TEM image of PE single crystal decorated with P3HT whiskers. (Pt shadowed). The P3HT whiskers grew normal to the (110) growth faces of the PE single crystal.

80 kV.

## RESULTS AND DISCUSSION

The morphology of the P3HT-decorated PE single crystals is shown in Figure 3. Whiskers were observed to crystallize onto three different substrate surfaces, i.e. the carbon supporting film, the fold and the lateral surfaces of the PE single crystals, respectively. No preferential orientation was found of the P3HT whiskers that were grown onto the large fold surface of the PE single crystals. The P3HT whiskers also were found on the amorphous carbon-supporting film, but more densely than onto the PE fold surface, and with a small, but noticeable degree of local order. The latter may be indicative of the occurrence of a self-ordering phenomenon of the whiskers during solvent evaporation, resembling the formation of lyotropic phases. Interestingly, the whiskers grown onto the lateral surface of the PE single crystals were aligned normal to it.

An electron diffraction pattern of a P3HT-decorated PE single crystal is shown in Figure 4. The diffraction spots in the figure constitute the  $hk0$  net pattern of the PE crystal; the ring in the pattern stems predominantly from the 020 planes of P3HT. Dark-field studies confirmed the previously mentioned parallelism between the P3HT

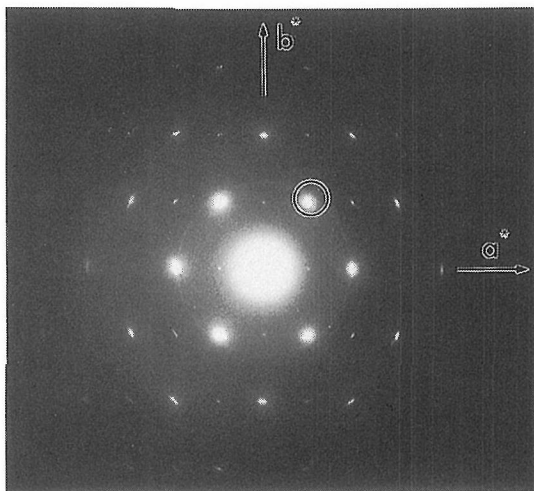

Fig. 4  
Electron diffraction pattern of PE single crystal decorated with P3HT whiskers. The diffraction spots show the  $hk0$  net pattern of PE. The diffraction ring predominantly stems from the 020 planes of P3HT. The circle in the figure shows the position of objective aperture for the dark-field image in Fig. 5.

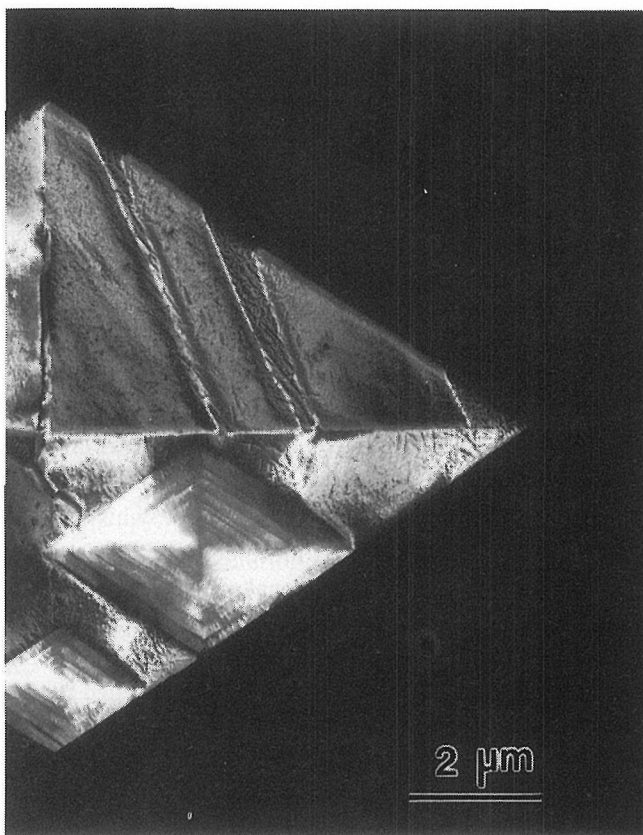

Fig. 5  
Dark-field image of PE single crystal decorated with P3HT whiskers. The whiskers having a direction parallel to the vector from the origin of the diffraction pattern to the circle in Figure 4 appear in this photomicrograph. Thus, the P3HT whiskers grown onto the lateral surface of PE single crystal are normal to (110) planes of PE.

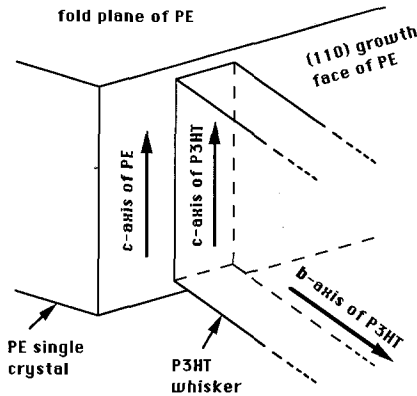

Fig. 6 Schematic drawing of the molecular orientations between P3HT whiskers and PE single crystal.

*b*-axis and the whisker direction. Indeed, the whiskers which appear bright in the dark-field image of Figure 5, i.e. which have their (020) plane parallel to the selected (110) PE plane (limiting the two dark sectors of the PE crystal) are all oriented in a normal direction to (110) of PE. Accordingly, the *a*- and *c*-axis of P3HT are oriented parallel to the PE {110} growth faces. Whether the P3HT *c*-axis (chain-axis) is oriented parallel (see proposed model in Figure 6) or not to the PE chains could not be determined from the available diffraction patterns alone. However, a similar decoration experiment performed on the surface of an ultra-drawn ( $\lambda \approx 100$ ) ultra-high molecular weight PE gel film (for preparation details see e.g. ref. 15) revealed that the P3HT chain molecules orient along the draw direction of PE. This experiment is in favor of the tentative model of the orientational relationship between P3HT whiskers and PE single crystals shown schematically in Figure 6.

In conclusion, it appears that the P3HT macromolecules preferred to orient onto the lateral surface rather than the large surface formed by the folded PE chains. The behavior of the P3HT molecules is, of course, very different from that of vapor-deposited PE molecules described above<sup>13)</sup>, which display preferential orientation onto the fold surface of the PE single crystals.

#### ACKNOWLEDGEMENT

The authors dedicate this paper to professor Ken-ichi Katayama of the Institute for Chemical Research, Kyoto University. We are grateful to Jeff Moulton (UCSB) for supplying the P3HT sample and for many valuable discussions. We are indebted to Jean Claude Wittmann for his comments and critical reading of the manuscript. This research was supported through a grant from the AFOSR, AF49620-88-C-0138.

#### REFERENCES

- (1) P.H. Geil, "Polymer Single Crystals", John Wiley and Sons, New York (1973)
- (2) B. Wunderlich, "Macromolecular Physics" vol. 1, Academic Press, New York (1976)

- (3) A. Keller, *Phil. Mag.*, **2**, 1171 (1957)
- (4) P.J. Flory, *J. Am Chem. Soc.*, **84**, 2857 (1962)
- (5) E.W. Fischer and R. Lorenz, *Kolloid Z. Z. Polym.*, **189**, 97 (1963)
- (6) M.I. Bank and S. Krim, *J. Polym. Sci.*, A-2, **7**, 1785 (1969)
- (7) T. Williams, D.J. Blundell, A. Keller and I.M. Ward, *J. Polym. Sci.*, A-2, **6**, 1613 (1968)
- (8) V.F. Holland, *J. Appl. Phys.*, **35**, 3235 (1964)
- (9) For example: "Organization of Macromolecules in the Condensed Phase", *Faraday Discuss. Chem. Soc.*, **69**, (1979)
- (10) K.J. Ihn, Doctoral thesis, Kyoto University (1990)
- (11) G.A. Bassett, D.J. Blundell and A. Keller, *J. Macromol. Sci.*, **B1**, 161 (1967)
- (12) J.C. Wittmann and B. Lotz, *Makromol. Chem.*, **175**, 1395 (1974)
- (13) J.C. Wittmann and B. Lots, *J. Polym. Sci., Polym. Phys.*, **23**, 205 (1985)
- (14) K.J. Ihn, J. Moulton and P. Smith, *Macromolecules*, submitted.
- (15) P. Smith, P.J. Lemstra, J.P.L. Pijpers and A.M. Kiel, *Colloid & Polym. Sci.*, **259**, 1070 (1981)