

---

 ABSTRACTS (MASTER THESIS)
 

---

**Development of configurable software-defined receiver for atmospheric radars**

(Graduate School of Informatics,  
 Laboratory of Radar Atmospheric Science, RISH, Kyoto University)

Toshiyuki Fujita

In the study, a new digital receiver for atmospheric radars was developed. The digital receiver comprises a general-purpose software-defined radio receiver referred to as Universal Software Radio Peripheral 2 (USRP2) and a commercial personal computer (PC), and the purchase price of USRP2 is less than USD 2000. The receiver is able to collect received signals at an intermediate frequency (IF) of 130 MHz with a sample rate of  $10 \text{ MS s}^{-1}$ . The USRP2 digitizes IF received signals, produces IQ time series, and then transfers the IQ time series to the PC through Gigabit Ethernet. The PC receives the IQ time series, performs range sampling, carries out filtering in the range direction, decodes phase-modulated received signals, integrates the received signals in time, and finally saves the processed data to the hard disk drive. Because only sequential data transfer from the USRP2 to the PC is available, the range sampling is triggered by the transmitted pulse leaked to the receiver. In order to perform range imaging with multiple frequencies, the digital receiver executes real-time signal processing for each of the time series collected at different frequencies. Further, in order to implement oversampling, the receiver is able to decode phase-modulated oversampled signals by interleaving oversampled signals in the range direction. Because the program code for real-time signal processing at the PC is written in the C++ language, the signal processing executed by the digital receiver is easy to implement, reconfigure, and reuse.

Using the measurement result from a 1.3-GHz range imaging atmospheric radar, we demonstrate that the digital receiver, which is capable of performing real-time signal processing for range imaging and oversampling, is useful for resolving fine-scale structure of atmospheric turbulence with a vertical scale as small as 100 m.

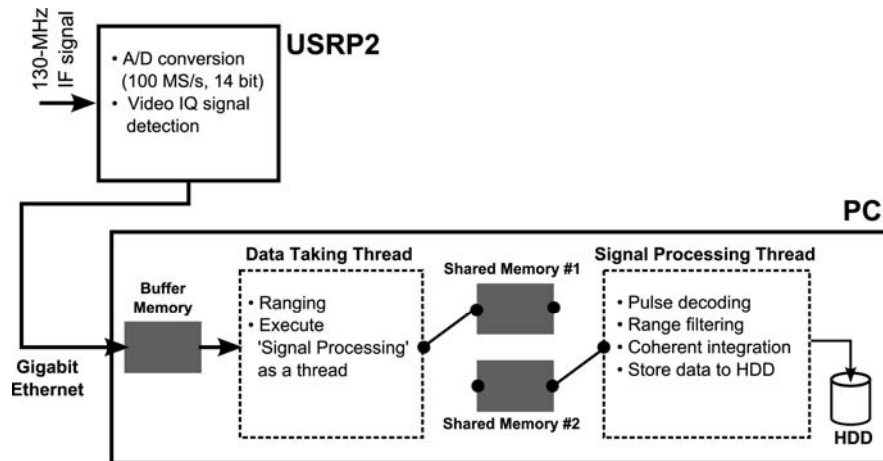

Figure 1. Signal flow diagram of the digital receiver.

### Acknowledgements

This research was supported by Adaptable and Seamless Technology Transfer Program through Target-Driven R&D (A-STEP) Exploratory Research (Research No. AS232Z00186A) funded by Japan Science and Technology Agency and the research grant for Mission Research on Sustainable Humanosphere from the Research Institute for Sustainable Humanosphere (RISH), Kyoto University.