

Calibration of a new Ar analytical system for the K-Ar dating method and analytical results of K-Ar age known samples

By

Masafumi SUDO*, Takahiro TAGAMI, Keiko SATO, Noriko HASEBE**
and Susumu NISHIMURA

Abstract

A new Ar analytical system at Kyoto University by sensitivity method which is suitable for dating of Neogene to Quaternary volcanic and tectonic events has been constructed and calibrated. Calibration has been performed using biotite mineral standard, Sori 93, in which the amount of radiogenic ^{40}Ar is known. The system consists of a VG Isotech 3600 mass spectrometer and the main sample handling system both for the extraction by tantalum resistance furnace and for the purification of sample gases. The errors of ^{40}Ar intensity, $^{40}\text{Ar}/^{36}\text{Ar}$ and $^{38}\text{Ar}/^{36}\text{Ar}$ of the system have been estimated to be 1.5%, 0.16% and 0.53%, respectively, by repeated standard air Ar analyses. The duplicate analyses have been done by the system using six K-Ar age mineral standards or K-Ar age known samples whose ages belong to Neogene or Quaternary. Most obtained K-Ar ages agree well with those in the literatures. There are no systematic errors among them. The ages of four Neogene samples (Bern4B, Bern4M, Baba Tuff biotite and NST30 biotite) has been obtained within about $\pm 2-3\%$ errors and that of one Quaternary sample (YZ1) within about $\pm 25-30\%$ errors. These implies that the Ar analytical system may be sufficiently useful for K-Ar dating of geological samples with younger ages than Neogene age.

1. Introduction

K-Ar dating has been widely used for determination of the ages of geological events (e.g. DALRYMPLE and LANPHERE, 1969). The reported applicable range of the youngest age reached to about 10,000 years (e.g. DALRYMPLE, 1967). This implies that K-Ar dating technique is very suitable to make clear the Quaternary geological events, such as volcanic and magmatic activities of Quaternary volcanoes. However, it has been suggested by several authors that Ar isotopic ratios of the volcanic rocks in recent ages mostly fell on the mass fractionation line from the atmospheric isotopic ratio (KRUMMENACHER, 1970;

Division of Earth and Planetary Sciences, Graduate School of Science, Kyoto University, Kyoto 606-01, Japan

* Present address: School of Earth Sciences, Integrated Human Studies, Kyoto University, Kyoto 606-01, Japan

** Present address: Department of Geology, Faculty of Science, Kanazawa University, Kanazawa 920-11, Japan

KANEOKA, 1980; MATSUMOTO et al., 1989a). This means that the fractionation influences the K-Ar dating of very young samples of Quaternary ages. TAKAOKA et al. (1989) suggested that K-Ar dating technique by peak height comparison method (sensitivity method) is suitable for the very young samples because it is able to correct the initial Ar isotopic ratio assuming mass fractionation from the atmospheric Ar isotopic ratio. MATSUMOTO et al. (1989b) performed the method of TAKAOKA et al. (1989), based on highly precise $^{38}\text{Ar}/^{36}\text{Ar}$ measurements and demonstrated that K-Ar age of 0.05 Ma of the ideal basaltic rock could be determined within 15% error (1σ) by VG1200 mass spectrometer at Geological Survey of Japan. MATSUMOTO and KOBAYASHI (1995) reported that the K-Ar ages of 21–86 ka from Ontake Volcano, central Japan, were good agreement with the geological sequences but those assuming the atmospheric initial Ar isotopic ratio were not. This implies that K-Ar dating method by this “mass fractionation correction procedure” whose name was proposed by MATSUMOTO and KOBAYASHI (1995) is very useful to date the very young samples.

A new Ar analytical system was introduced to Kyoto University in 1993. The system consists of VG Isotech 3600 mass spectrometer and the handling sample system both for extraction and purification of sample gases. In this system, sensitivity method without ^{38}Ar spike was adopted to apply the system to date the Cenozoic geological events. It has been calibrated by the internal biotite mineral standard of Kyoto University, Sori 93, which was prepared and determined the radiogenic ^{40}Ar concentration by Kyoto University and Geological Survey of Japan (SUDO et al., in prep.). The calibration has been examined by analyses of several K-Ar age standard minerals and K-Ar age known samples. In the present paper, the description of the Ar analytical system, the results of calibration by Sori 93 and those of analyses of the age known samples are presented.

2. Argon analytical system and analytical procedure

2-1. Principle of K-Ar dating

K-Ar dating technique has been summarized or explained by many authors (e.g. Dalrymple and Lanphere, 1969). The summary of the principle of this technique is as follows. K-Ar dating is based on the fact that ^{40}K decays to ^{40}Ar or ^{40}Ca with a half life of 1.25×10^9 years (STEIGER and JÄGER, 1977). K-Ar age can be calculated by the equation (1).

$$t = \frac{1}{(\lambda_e + \lambda_\beta)} \ln \left[\frac{^{40}\text{Ar}_{(\text{rad.})}}{^{40}\text{K}} \left(\frac{\lambda_e + \lambda_\beta}{\lambda_e} \right) + 1 \right] \quad (1)$$

t: K-Ar age

λ_e : Decay constant from ^{40}K to ^{40}Ar ($0.581 \times 10^{-10}/\text{y}$)

λ_β : Decay constant from ^{40}K to ^{40}Ca ($4.962 \times 10^{-10}/\text{y}$)

$^{40}\text{Ar}_{(\text{rad.})}$: Concentration of radiogenic ^{40}Ar (mol/g)

^{40}K : Concentration of radiogenic ^{40}K (mol/g)

It is assumed that the present atomic abundance ratio of ^{40}K to total potassium in terrestrial rocks and minerals is constant to be 1.167×10^{-4} (STEIGER and JÄGER, 1977). Then, the concentration of ^{40}K can be calculated from the total potassium concentration.

The radiogenic ^{40}Ar is determined by the sensitivity method. The concentration of the total ^{40}Ar in a sample is obtained by the comparison of peak intensity with the known amount of the standard air sample. The concentration of radiogenic ^{40}Ar is calculated by the equation (2).

$$^{40}\text{Ar}_{(\text{rad.})} = ^{40}\text{Ar}_{(\text{total})} \cdot (\text{R} - \text{R}_0) / \text{R} \quad (2)$$

$^{40}\text{Ar}_{(\text{total})}$: Concentration of total ^{40}Ar in a sample

R_0 : Initial $^{40}\text{Ar}/^{36}\text{Ar}$ ratio

R : $^{40}\text{Ar}/^{36}\text{Ar}$ ratio in a sample

The initial $^{40}\text{Ar}/^{36}\text{Ar}$ ratio in a sample is assumed to be equal to that of the atmospheric value in the conventional K-Ar dating. However, because Ar isotopic ratios of the volcanic rocks in recent ages mostly fell on the mass fractionation line from the atmospheric ratio (KRUMMENACHER, 1970; KANEOKA, 1980; MATSUMOTO et al., 1989a), the initial $^{40}\text{Ar}/^{36}\text{Ar}$ ratio is estimated by assuming that initial $^{40}\text{Ar}/^{36}\text{Ar}$ ratios in all volcanic rocks lie on the fractionation line from the atmospheric ratio. The estimation of the initial $^{40}\text{Ar}/^{36}\text{Ar}$ ratio is shown in equations (3) and (4), which follow the procedure of TAKAOKA et al. (1989) and MATSUMOTO et al. (1989b).

$$\delta = (r/r_A - 1) / 2 \quad (3)$$

$$\text{R}_0 = \text{R}_A \cdot (1 + 4\delta) \quad (4)$$

R_0 : Estimated initial $^{40}\text{Ar}/^{36}\text{Ar}$ ratio in a sample

R_A : $^{40}\text{Ar}/^{36}\text{Ar}$ ratio in the present atmosphere (295.5; NIER, 1950)

δ : Degree of fractionation per a unit of mass difference

r_A : $^{38}\text{Ar}/^{36}\text{Ar}$ ratio in the present atmosphere (0.1869; NIER, 1950)

r : $^{38}\text{Ar}/^{36}\text{Ar}$ ratio in a sample

The calculation of the uncertainty for age determinations by the sensitivity method is summarized in MATSUMOTO et al. (1989b). The calculation follows the equations (5)–(8). These equations are introduced by the application of “law of propagation of errors” into the equations (1)–(4).

$$\sigma_T^2 = \sigma_K^2 + \sigma_{Ar}^2 \quad (5)$$

$$\sigma_{Ar}^2 = \sigma_x^2 + \frac{A_c^2}{(1-A_c)^2} (\sigma_R^2 + \sigma_{R0}^2) \quad (6)$$

$$\sigma_{R0}^2 = 2r \cdot \sigma_r / (2r - r_A) \quad (7)$$

$$A_c = (2r - r_A) \cdot R_A / (r_A \cdot R) \quad (8)$$

σ_T : Relative error for K-Ar age

σ_K : Relative error for determination of potassium

σ_{Ar} : Relative error for determination of radiogenic ^{40}Ar

σ_x : Relative error for determination of total ^{40}Ar

σ_R : Relative error for determination of $^{40}\text{Ar}/^{36}\text{Ar}$ ratio

σ_{R0} : Relative error for initial $^{40}\text{Ar}/^{36}\text{Ar}$ ratio

σ_r : Relative error for determination of $^{38}\text{Ar}/^{36}\text{Ar}$ ratio

A_c : Fraction of atmospheric argon

The estimation of σ_x , σ_R and σ_{R0} are discussed later.

2-2. Argon analytical system

The Ar analytical system mainly consists of VG Isotech 3600 mass spectrometer and the main sample handling system for extraction and purification of sample gases made by Ayumi Co. Ltd. Most of them are made of stainless tubes.

VG Isotech 3600 mass spectrometer is a high performance magnetic sector mass spectrometer for the analysis of small samples of noble gases. It employs the static vacuum mode of operation (static volume is 1100 cm³). It is a single focussing type with 60° extended geometry ion optics giving a dispersion length of 36 cm. The flight tube lies in the horizontal plane. The ion source is NIER type VG Bright source. The collector assembly is a single off-axis (high mass side) Faraday collector and an evacuated head amplifier. The defining slit is set at 250 resolution and the amplifier at 10¹¹ ohm resistor. The vacuum inside the mass is normally attained to the order of 10⁻¹⁰ torr by pumping with a Varian 30 l/s ion pump and two SAES getter pumps at room temperature. The sample analyses are done by peak jumping procedure controlled by the personal computer.

The arrangement of the handling sample system and the mass spectrometer is illustrated in Figure 1. The main sample handling system is subdivided into three sections: (1) gas extraction, (2) gas purification and (3) the standard air pipette system. (1) The extraction of sample gases is done with a tantalum resistance heater by heating samples in the molybdenum crucible and the tantalum tube in the extraction line. The temperature of the heater is automatically controlled. The inside of the extraction line and the tantalum heater room are pumped out with Mitsubishi 30 and 45 l/s turbo molecular

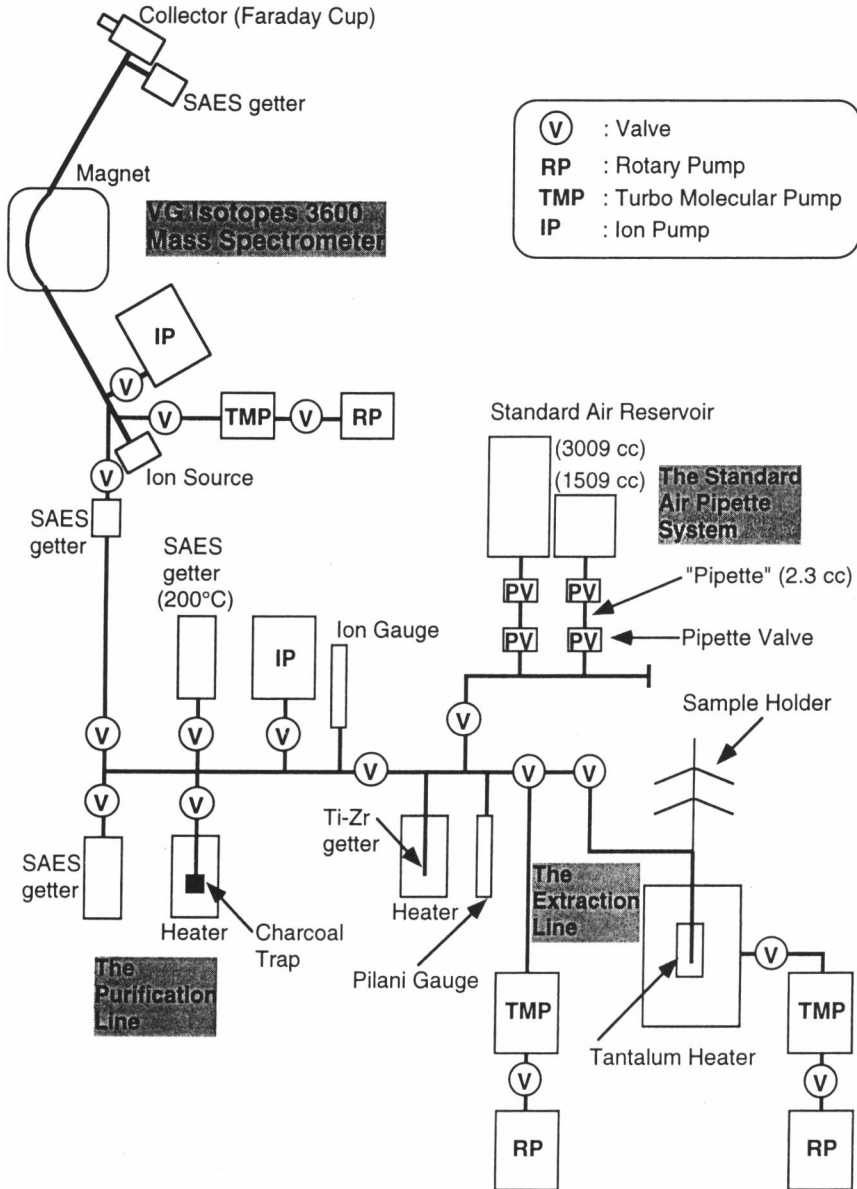

Figure 1. The arrangement of the Ar analytical system. It consists of a VG Isotech 3600 mass spectrometer, the purification line, the extraction line and the standard air pipette system.

pumps, respectively. (2) The purification of the sample gases is done with three getters in the purification line. They are a Ti-Zr getter heated at more than 700°C and two SAES Zr-Al getters heated at 200°C and kept at room temperature, respectively. The charcoal trap is also equipped for collecting purified Ar gas. The inside of the purification line is normally pumped out with a Mitsubishi 30 l/s turbo molecular pump or a Varian 30 l/s ion pump. The vacuum is attained to the order of 10^{-10} torr in the good conditions. (3) The standard air pipette system consists of the reservoir (1509 and 3009 cm³: estimated by Ayumi Co. Ltd.) of standard air Ar and the pipette (2.3 cm³: estimated by Ayumi Co. Ltd.) with two pipette valves. In this work, the reservoir of 1509 cm³ and the pipette system were used.

2-3. Analytical procedure

The extraction, purification and analytical procedure are fundamentally similar to those of NAGAO and ITAYA (1988), TAKAOKA et al. (1989) and MATSUMOTO et al. (1989b).

The rock, powder or mineral sample of 0.01–1.5 g is wrapped by a sheet of copper foil about 0.1 g. The samples are loaded in the sample holder made of pyrex glass. Then, the samples are baked out at about 140°C during more than a day pumping the inside of the extraction line with a turbo molecular pump to remove adsorbed atmospheric Ar on the surface of the samples. After the baking, the extraction line is isolated from the pump. Then, the sample is fallen into the molybdenum crucible using hand magnet and is fused by tantalum heater at 1500–1600°C for 20 minutes. The extracted gases are simultaneously purified by Ti-Zr getter at more than 700°C for 35 minutes to remove active gases such as O₂, N₂ and CO₂ and decompose H₂O, and at room temperature for 10 minutes. Then, purified gases are collected to the charcoal trap kept at liquid nitrogen temperature and more purified with a SAES Zr-Al getter at 200°C for 10 minutes to remove mainly hydrocarbon. Finally, the gases are purified with a SAES Zr-Al getter at room temperature for 10 minutes to remove mainly hydrogen, and are introduced to the mass spectrometer. The analytical condition of mass spectrometer is shown in Table 1. The relation between the magnetic fields and each Ar isotopic mass is initially calibrated by a personal computer using mass calibration program of VG Isotech software. The calibration is sometimes renewed to remove deviations accumulated for a long term. The analyses and calculations of Ar contents and isotopic ratios are also done using the program of VG isotech software. Three isotopes of ³⁶Ar, ³⁸Ar and ⁴⁰Ar are analyzed in the specified integration time, shown in Table 2, to each isotope by 11 cyclic jumping on the centered flat top peaks of the three isotopes and several background magnetic fields. The ⁴⁰Ar contents are mostly regressed by the curve fit and are extrapolated to the zero time when Ar gas is introduced to the mass spectrometer. The ⁴⁰Ar/³⁶Ar and ³⁸Ar/³⁶Ar ratios during the analysis are calculated by the equation of Dodson (1978). Consequently the ratios are mostly regressed by the straight fit and similarly extrapolated to the zero

Table 1. The analytical condition of the VG3600 mass spectrometer.

Ion accelerating voltage	4.6 kV
Filament current	2.7 A
Trap current	200 μ A
Emission current	1 mA
Repeller voltage	-7 to -6 V
Magnet current	1.7-1.85 A
Slit width	1 mm
Collector	Faraday cup

Table 2. The integration time of each Ar isotope in analyses.

No.	Mass Number	Integration time (sec.)		Comments
		(Sample)	(Blank)	
1	35.567	4	10	baseline for ^{36}Ar
2	35.967	10	13	^{36}Ar peak
3	36.467	4	10	baseline for ^{36}Ar and ^{38}Ar
4	37.962	12	15	^{38}Ar peak
5	38.462	4	15	baseline for ^{38}Ar and ^{40}Ar
6	39.962	4	4	^{40}Ar peak

time.

3. Calibration of the system

3-1. Analyses of standard air Ar

In the K-Ar dating using sensitivity method the intensity of radiogenic ^{40}Ar of the unknown sample is compared with the ^{40}Ar intensity of the standard air Ar sample usually analyzed in the same day, and then the concentration of radiogenic ^{40}Ar is consequently determined. The fundamental assumption is that the sensitivities are almost same between the analyses of an unknown sample and a standard air Ar sample.

Figure 2 indicates the variation of the ^{40}Ar intensity, $^{40}\text{Ar}/^{36}\text{Ar}$ and $^{38}\text{Ar}/^{36}\text{Ar}$ of the results of 37 times standard air Ar analyses during 6 months. The air Ar samples of No. 31–33 have been measured in a day. The variation of the ^{40}Ar intensities, 5.561, 5.599 and 5.609 volt, is within 1% and very small although the ^{40}Ar intensity theoretically de-

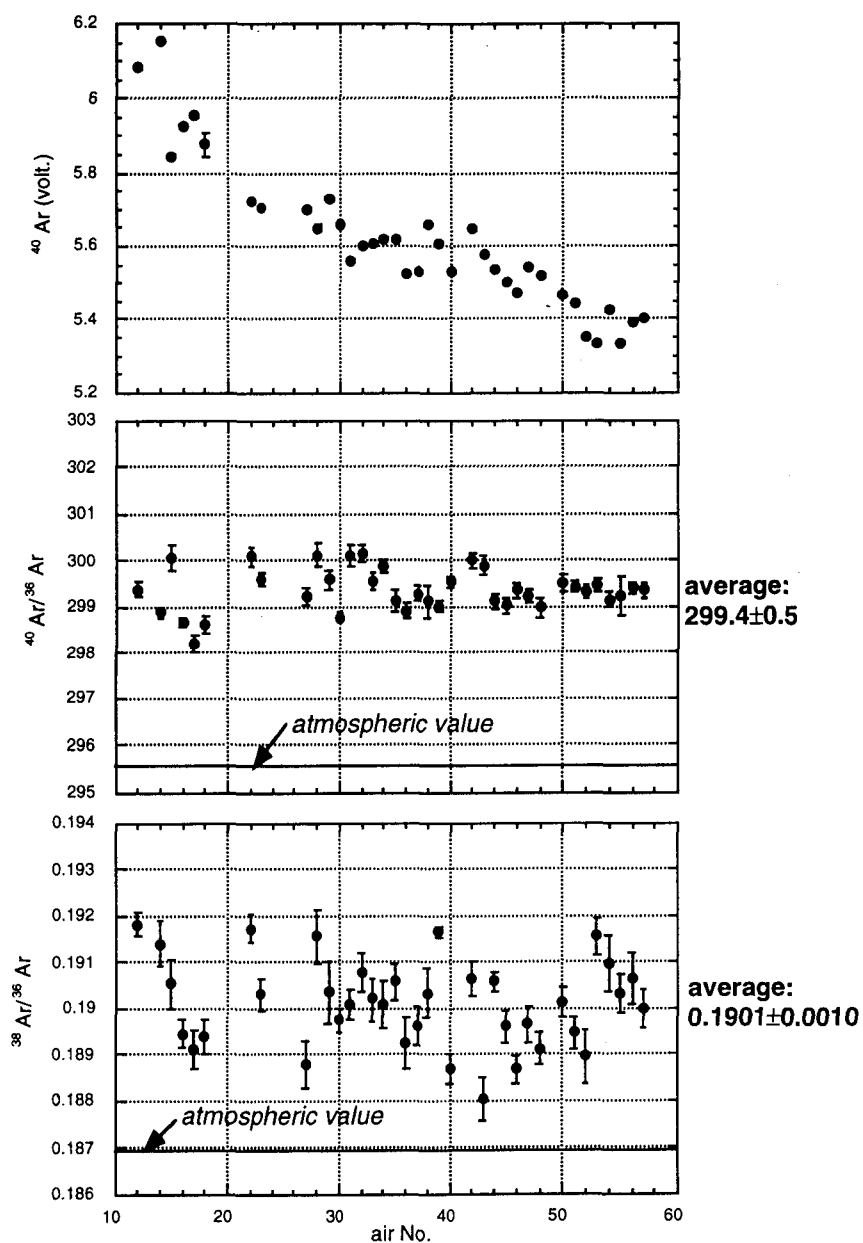

Figure 2. The analytical results of variation in ^{40}Ar contents, $^{40}\text{Ar}/^{36}\text{Ar}$ and $^{38}\text{Ar}/^{36}\text{Ar}$ ratios of standard air Ar according to pipetting operations during 6 months. The error bars of all plotting points indicate analytical error in each analysis ($\pm 1\sigma$). Some error bars are hidden in the plotting points.

increases in every analysis because of the dilution of the standard air Ar by pipetting. Therefore, the fundamental assumption of sensitivity method is considered to be satisfied. Even if theoretical decrease of ^{40}Ar intensity is accepted, it seems that the sensitivity is almost stable. The depletion rate of the standard air Ar will be discussed in the next section, 3-2. The ratios of $^{40}\text{Ar}/^{36}\text{Ar}$ and $^{38}\text{Ar}/^{36}\text{Ar}$ also seem to be stable during 6 months (Figure 2). The averaged $^{40}\text{Ar}/^{36}\text{Ar}$ and $^{38}\text{Ar}/^{36}\text{Ar}$ and the standard deviations are 299.4 ± 0.5 (0.16%) and 0.1901 ± 0.0010 (0.53%), respectively. These $^{40}\text{Ar}/^{36}\text{Ar}$ and $^{38}\text{Ar}/^{36}\text{Ar}$ ratios are significantly higher than the atmospheric $^{40}\text{Ar}/^{36}\text{Ar}$ and $^{38}\text{Ar}/^{36}\text{Ar}$ ratios of 295.5 and 0.1869 (NIER, 1950; STEIGER and JÄGER, 1977). This implies that mass discrimination corrections are necessary in the sample analyses. Therefore, mass discrimination is corrected in a usual analysis. The equation and the error for mass discrimination correction (MATSUMOTO et al., 1989 a; MATSUMOTO, 1990) are summarized in the Appendix of this paper.

The other important fundamental assumption is the linearity of the sensitivity between Ar gas volume and the intensity. To examine the linearity, intensities of ^{40}Ar have been analyzed by repeating the same procedure of dilution of the regular content of standard air Ar. The linearity is confirmed in the ^{40}Ar intensities at least more than 0.05 volt (Figure 3).

3-2. Calibration of standard air Ar

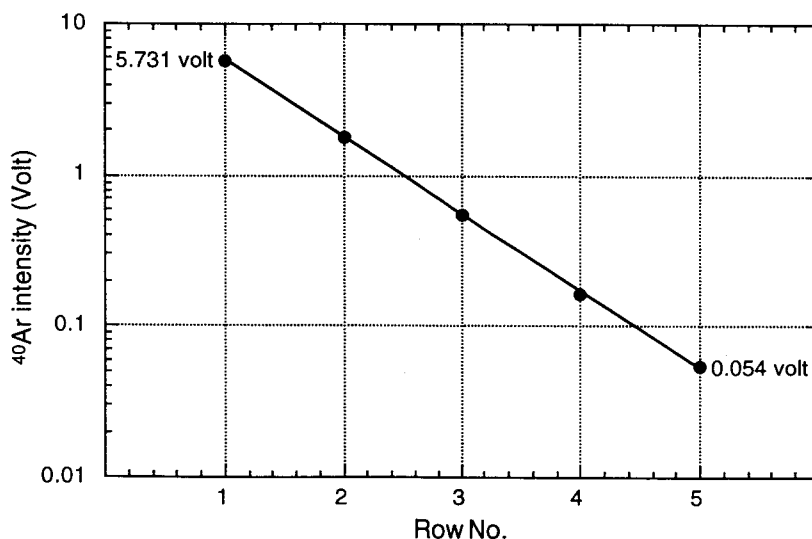

Figure 3. Intensities of ^{40}Ar peaks analyzed by repeating the same procedure of dilution of the regular content of standard air Ar. The linearity of the sensitivity is confirmed more than 0.05 volt. The error bars of the analytical error ($\pm 1\sigma$) are hidden in the plotting points.

Calibration of the standard air Ar sample has been performed as follows. The internal mineral standard of Kyoto University, Sori 93 whose radiogenic ^{40}Ar concentration is known to be $25.0 \pm 0.2 \text{ cm}^3\text{STP/g}$ (Sudo et al., in prep.), has been used. The biotite samples and the standard air Ar sample have been alternatively analyzed 5 times over 3 months. In each analysis, about 0.015 g of Sori 93 was used. The ^{40}Ar content of each standard air Ar sample has been calculated by the sensitivity which is the ratio of the radiogenic ^{40}Ar intensity (volt) to the amount (cm^3STP) of that of the Sori 93 biotite. The results of 5 times determination of ^{40}Ar content in the standard air Ar are listed in Table 3.

The five ^{40}Ar contents of standard air Ar have been regressed by exponential fitting following the next equation:

$$^{40}\text{Ar}_{(n)} = ^{40}\text{Ar}_{(i)} * \delta^{(n-1)}$$

$^{40}\text{Ar}_{(n)}$: ^{40}Ar content of standard air Ar of n times pipetting

$^{40}\text{Ar}_{(i)}$: initial ^{40}Ar content of standard air Ar

δ : depletion rate; $\left(= \frac{\text{Volume of air Ar reservoir} - \text{Volume of pipette}}{\text{Volume of air Ar reservoir}} \right)$

Obtained initial content and depletion rate also listed in Table 4. The depletion rate of 0.9981 has been adopted because the rate of 0.9985 obtained from the volume (standard air Ar reservoir: 1509 cm^3 , the pipette: 2.3 cm^3) estimated by Ayumi Co. Ltd. is similar to the rate by exponential fitting. The consequently obtained equation of depletion of standard air Ar is as follows:

$$^{40}\text{Ar}_{(n)} = (3.574 \times 10^{-7}) \cdot 0.9981^{(n-1)} (\text{cm}^3\text{STP})$$

The error of determination of ^{40}Ar content is 0.91% (Table 4). This is derived by the next equation:

$$\sigma = (1/(n-2) \cdot \sum d^2)^{1/2}$$

N: Number of determination of ^{40}Ar content of standard air Ar

d: deviation from the regression curve

The stability of the sensitivity ($\text{Volt}/\text{cm}^3\text{STP}$) has been examined by the Sori 93 analyses data. The five sensitivity during 3 months is very concordant and the average sensitivity is $1.681 \times 10^7 \text{ Volt}/\text{cm}^3\text{STP}$. The standard deviation is $1.9 \times 10^9 \text{ Volt}/\text{cm}^3\text{STP}$ (1.1%) (Table 4). This confirms the stability of the system and suggests good repro-

Table 3. Results of calibration of standard air Ar using Sori 93.

air No.	^{40}Ar in air ($\times 10^{-7}$ cm^3STP)	Regressed value ($\times 10^{-7}$ cm^3STP)	difference ($\times 10^{-7}$ cm^3STP)	difference %	Sensitivity ($\times 10^{-7}$ Volt / cm^3STP)
16	3.465	3.471	0.006	0.18	1.687
35	3.304	3.345	0.041	1.23	1.701
36	3.369	3.339	0.030	0.90	1.654
39	3.313	3.319	0.006	0.19	1.693
46	3.266	3.275	0.009	0.26	1.669

Table 4. Regression results.

depletion rate	0.9981	
(*Data of Ayumi Co. Ltd.)	*0.9985	
V1 volume	3.574	($\times 10^{-7}$ cm^3STP)
apparent pipette volume	2.9170	(cm^3STP)
(*Data of Ayumi Co. Ltd.)	*2.3	(cm^3STP)
SDOM of difference	3.038	($\times 10^{-9}$ cm^3STP)
SDOM of difference %	0.91	
Average sensitivity	1.681 \pm 0.019 (\pm 1.1%) ($\times 10^{-7}$ Volt / cm^3STP)	

SDOM = standard deviation of mean

ducibility of biotite sample analyses.

3-3. Blanks of the analytical system

A cold blank is analyzed by the same procedure of the unknown sample analysis without operating tantalum resistance furnace. The 3 times analytical results of ^{40}Ar during 6 months distribute from 0.007 to 0.073 volt. The intensities correspond to the ^{40}Ar volume from 4.2×10^{-10} to 4.3×10^{-9} cm^3STP if the sensitivity is assumed to be above mentioned 1.681×10^7 Volt/ cm^3STP .

A hot blank is analyzed by the same procedure of the unknown sample analysis without the sample. The 25 times analytical results of ^{40}Ar during 6 months distribute from 0.017 to 0.533 volt. The intensities correspond to the ^{40}Ar volume from 1.0×10^{-9} to 3.2×10^{-8} cm^3STP if the sensitivity is assumed to be 1.681×10^7 Volt/ cm^3STP .

In the sample analysis, the sample is wrapped by about 100 mg of copper foils. A sheet of copper foil of 100 mg has been analyzed. The total ^{40}Ar in the copper foil is lower than the hot blank at that time. Therefore, the amount of ^{40}Ar in the copper foil has been obtained by the upper limit (See Table 5 in the next section). This implies that the amount of ^{40}Ar in the copper foil is practically much smaller than hot blanks

Table 5. Argon analytical results of reference samples.

Sample Name	Mineral	Weight (g)	K ₂ O (%)	³⁸ Ar/ ³⁶ Ar	⁴⁰ Ar/ ³⁶ Ar	⁴⁰ Ar rad. (10 ⁻⁸ cm ³ STP/g)	Atm. ⁴⁰ Ar (%)	Age (Ma)
Bern4B	biotite	0.0627	<i>a</i> 9.53±0.10	0.1913±0.0015	1819±5	522±8	16.2	16.9±0.4
		0.0615		0.1932±0.0016	1717±5	534±9	17.2	17.3±0.4
			<i>b</i> 9.47±0.02			<i>b</i> 515±10	<i>b</i> 14.7-20.9	<i>b</i> 16.9±0.3
			<i>a</i> 9.53±0.10			<i>a</i> 533±6		<i>a</i> 17.3±0.2
Bern4M	muscovite	0.0215	<i>a</i> 10.46±0.10	0.1871±0.0021	846.4±2.8	600±10	34.9	17.7±0.4
		0.0412		0.1859±0.0011	811.1±1.5	593±9	36.4	17.5±0.4
			<i>a</i> 10.46±0.10			<i>a</i> 630±13		<i>a</i> 18.6±0.4
FC3	biotite	0.0436	<i>b</i> 8.90±0.04	0.1859±0.0039	3258±32	815±13	9.1	28.1±0.5
		0.0393		0.1828±0.0038	1879±3	836±13	15.7	28.9±0.5
			<i>b</i> 8.90±0.04			<i>b</i> 790±14	<i>b</i> 11.4-16.1	<i>b</i> 27.5±0.5
			<i>c</i> 8.92			<i>c</i> 847, 814, 784	<i>c</i> 34.6-48.1	<i>c</i> 28.1±1.1
(Fish Canyon Tuff) <i>d</i>		<i>d</i> 8.92			<i>d</i> 788		<i>d</i> 27.2±0.2	
YZ1	whole rock	1.0022	<i>g</i> 1.70±0.04	0.1880±0.0023	320.8±0.5	1.15±0.39	92.1	0.21±0.08
		1.0064		0.1908±0.0024	336.6±1.0	0.80±0.22	87.8	0.15±0.04
			<i>e</i> 1.70			<i>b e</i> 1.14±0.07		<i>e</i> 0.21
			<i>b</i> 1.698±0.005			<i>b</i> 1.20±0.04	<i>b</i> 78.4-80.3	<i>b</i> 0.219±0.008
			<i>f</i> 1.70±0.04			<i>f</i> 1.20±0.06	<i>f</i> 83.6-85.8	<i>f</i> 0.22±0.01
			<i>g</i> 1.70±0.04			<i>g</i> 1.194±0.058	<i>g</i> 79.2-85.9	<i>g</i> 0.218±0.011

(to be continued)

Table 5. (Continued)

Sample Name	Mineral	Weight (g)	K ₂ O (%)	³⁸ Ar/ ³⁶ Ar	⁴⁰ Ar/ ³⁶ Ar	⁴⁰ Ar rad. (10 ⁻⁸ cm ³ STP/g)	Atm. ⁴⁰ Ar (%)	Age (Ma)
Baba Tuff	biotite	0.0696	<i>h</i> 7.90±0.11	0.1859±0.0050	2599±27	305±5	11.4	11.9±0.3
		0.0649		0.1929±0.0053	3056±32	337±6	9.7	13.2±0.3
			<i>h</i> 7.90±0.11			<i>h</i> 296±10	<i>h</i> 5.1-59.4	<i>h</i> 11.6±0.4
NST30	biotite	0.0299	<i>i</i> 8.22±0.04	0.1887±0.0011	672.7±1.1	572±9	43.5	21.4±0.4
		0.0390		0.1880±0.0010	681.7±1.1	571±9	43.0	21.4±0.4
		<i>i</i> 0.0391	<i>i</i> 8.22±0.04	<i>i</i> 0.1876±0.0012	<i>i</i> 787.8±1.1	<i>i</i> 559±8	<i>i</i> 37.5	<i>i</i> 21.0±0.3
(NST) <i>h</i>		<i>j</i> 8.38±0.04				<i>j</i> 34.1-37.1	<i>j</i> 20.99±0.14	
Cu foil (no hot blank correction)		0.1189		0.1872±0.0029	296.2±2.3	* < 18.1 (total ⁴⁰ Ar)		

In the sample analysis, hot blank and mass discrimination is corrected.

Hot Blank (1500°C, 25 times), total ⁴⁰Ar : 1 × 10⁻⁹ to 3.2 × 10⁻⁸ cm³STP, ³⁸Ar/³⁶Ar : 0.1776-0.1927, ⁴⁰Ar/³⁶Ar : 285.8-310.9)

*Total ⁴⁰Ar in the copper foil was less than the hot blank at that time. Therefore, it is indicated by the upper limit.

Errors are ±1 σ throughout.

^a Flisch (1982 ; See McDougall and Harrison, 1988) ; ^b Matsumoto et al. (1989) ; ^c Uchiumi et al. (1989) ; ^d Hurford and Hammerschmidt (1985) ; ^e Takaoka (1989 ; See Nagao et al., 1991) ; ^f Itaya et al. (1991) ; ^g Nagao et al. (1991) ; ^h Takahashi et al. (1992) ; ⁱ (Unpublished data measured in Geological Survey of Japan) ; ^j Tagami et al. (1995)

and may be negligible.

In usual Ar analyses, only a hot blank is corrected because cold blanks are usually included in hot blanks and the Ar gas derived from copper foils is negligible. The hot blank correction and the error (MATSUMOTO et al., 1989a; MATSUMOTO, 1990) is shown in the Appendix of this paper.

3-4. Error estimation of ^{40}Ar contents and Ar isotopic ratios

Error of the K-Ar age is derived from errors of K_2O and radiogenic ^{40}Ar concentrations as equations (5). Error of the radiogenic ^{40}Ar concentration is derived from errors of $^{40}\text{Ar}/^{36}\text{Ar}$, $^{38}\text{Ar}/^{36}\text{Ar}$, the total ^{40}Ar content, and the atmospheric fraction of the total ^{40}Ar content as equations (6)–(8). Errors of $^{40}\text{Ar}/^{36}\text{Ar}$, $^{38}\text{Ar}/^{36}\text{Ar}$ and total ^{40}Ar are estimated as follows.

The standard deviations of $^{40}\text{Ar}/^{36}\text{Ar}$ and $^{38}\text{Ar}/^{36}\text{Ar}$ of standard air Ar analyses during 6 months are 0.16 and 0.53%, respectively. They are larger than the error in each analysis of usual standard air Ar analyses (Figure 2). Therefore, the lowest errors of $^{40}\text{Ar}/^{36}\text{Ar}$ and $^{38}\text{Ar}/^{36}\text{Ar}$ are estimated to be 0.16 and 0.53%. If analytical errors of $^{40}\text{Ar}/^{36}\text{Ar}$ or $^{38}\text{Ar}/^{36}\text{Ar}$ ratios are higher than the values, errors are adopted the analytical errors.

The error of total ^{40}Ar is estimated as follows. The ^{40}Ar contents of standard air Ar analyses and those by correction of depletion rate during 6 months are shown in Figure 4. The fluctuation of corrected ^{40}Ar contents may be primarily considered to reflect the fluctuation of the sensitivities because the fluctuation is much larger than the analytical error (Figure 4). The averaged corrected ^{40}Ar content and its standard deviation are 6.004 and 0.087 (1.5%). This value of 1.5% is also much larger than the analytical error. Therefore, error of total ^{40}Ar is estimated to be 1.5%.

4. K-Ar dating results of some age known samples

In order to confirm the calibrated Ar analytical system, several mineral standards of K-Ar ages and K-Ar age known samples have been analyzed in this system. Duplicate Ar analyses of six samples have been performed. The K_2O concentrations used in calculating K-Ar ages are derived from the literatures. The results are summarized as follows and in Table 5.

Bern4B and Bern4M

Bern4B and Bern4M (JÄGER et al., 1963) are widely known mineral standards of K-Ar and Rb-Sr dating. The radiogenic ^{40}Ar and the K-Ar age are reported to be $533 \pm 6 \times 10^{-8} \text{ cm}^3\text{STP/g}$ and $17.3 \pm 0.2 \text{ Ma}$ of Bern4B and $630 \pm 13 \times 10^{-8} \text{ cm}^3\text{STP/g}$ and $18.6 \pm 0.4 \text{ Ma}$ of Bern4M (FLISCH, 1982; McDOUGALL and HARRISON, 1988). The K-Ar

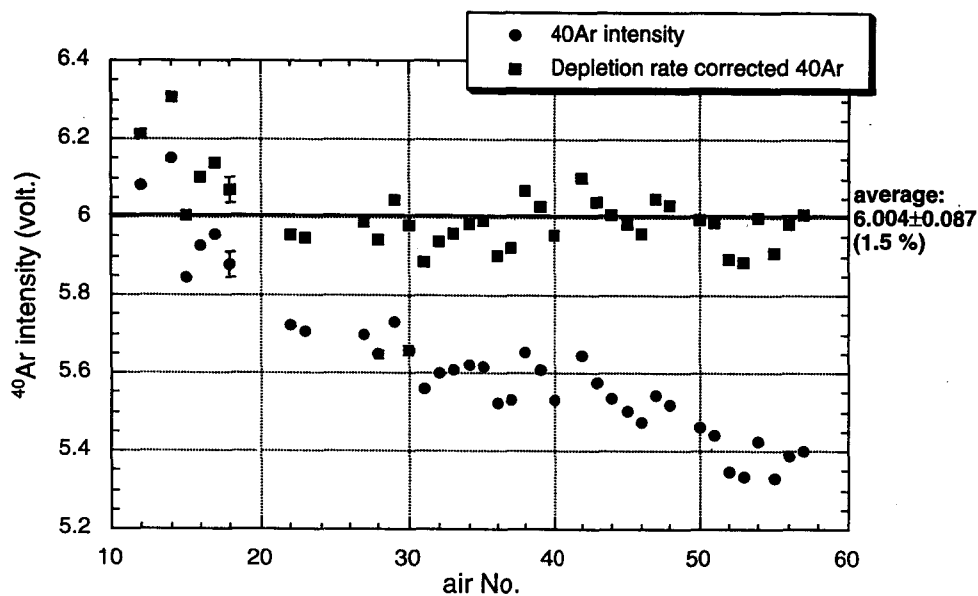

Figure 4. The ^{40}Ar contents of standard air Ar analytical results and those obtained by correction of depletion rate, 0.9981. The error bars indicate the analytical error ($\pm 1\sigma$) in each analysis. Most error bars are hidden in the plotting points. The fluctuation of the corrected ^{40}Ar content may be primary considered to be that of the sensitivities.

ages of Bern4B of duplicate analyses agree well with the ages of the literature. The K-Ar ages of Bern4M of duplicate analyses agree with the ages of the literature within 2σ although they are slightly younger than those of the literature.

Fish Canyon Tuff biotite

Fish Canyon Tuff in southwestern U. S. A. is well dated both by K-Ar and fission-track methods (HURFORD and HAMMERSCHMIDT, 1985). The Fish Canyon Tuff biotite, FC-3, was separated in Geological Survey of Japan from the sample collected at the same outcrop as used for the fission-track standard (MATSUMOTO et al., 1989). The FC-3 biotite has been used in the analysis. The K-Ar ages of FC-3 of duplicate analyses agree with previous obtained ages by MATSUMOTO et al. (1989) and UCHIUMI et al. (1989) within 2σ although they are slightly older than the ages of the literature. The ages are significantly older than that of the Fish Canyon Tuff biotite by HURFORD and HAMMERSCHMIDT (1985). The difference of the ages may be probably caused by that the FC-3 biotite is not derived from the same rock as the "Fish Canyon Tuff biotite" by HURFORD and HAMMERSCHMIDT (1985).

YZ1

YZ1 is a K-Ar age reference material of a Quaternary lava flow sample from Zao volcano which Takaoka (1988; 1989) provided for interlaboratory cross checking. Many laboratories of K-Ar dating in Japan reported the K-Ar ages of YZ1 (MATSUMOTO et al., 1989b; ITAYA et al., 1991; NAGAO et al., 1991). The K-Ar ages of duplicate analyses have been obtained by using corrected initial $^{40}\text{Ar}/^{36}\text{Ar}$ ratio due to "mass fractionation correction procedure" (MATSUMOTO et al., 1989b; MATSUMOTO and KOBAYASHI, 1995). The ages agree with the ages of the literature within 2σ although one of them is slightly younger than those of the literature.

Baba tuff

The Baba and Kitamura Tuffs in Gumma Prefecture were dated by K-Ar and $^{40}\text{Ar}/^{39}\text{Ar}$ methods (TAKAHASHI et al., 1992) because they were considered to be key tuffs for the determination of two correlation models of Middle and Late Miocene geomagnetic reversal sequences between the marine magnetic anomaly patterns and the magnetostratigraphy of sediment sections. The K-Ar age and $^{40}\text{Ar}/^{39}\text{Ar}$ plateau age were reported to be 11.6 ± 0.4 Ma and 11.9 ± 0.8 Ma, respectively. Since abundant biotites are comprised in the Baba tuff, they were abundantly prepared in Yamagata University and dated by K-Ar method in some laboratories in Japan. One of the K-Ar ages obtained by duplicate analyses agree well with the reported age within 2σ but the other does not. It is not understood well why one K-Ar age is older than the age of the literature. If any, one possibility might be derived from the mistake to weigh these samples. If the weights of two Baba Tuff biotite (0.0696 g and 0.0649 g) are exchanged, the ages are 12.8 ± 0.3 Ma and 12.3 ± 0.3 Ma and agree with the reported age within 2σ .

NST30

The Nisatai Dacite in Iwate Prefecture contains a sufficient amount of fresh, euhedral biotite and zircon crystals suitable for K-Ar and fission-track analyses, and the K-Ar and fission-track ages were reported to be 20.99 ± 0.28 Ma and 22.8 ± 1.0 Ma, respectively (TAGAMI et al., 1995; Errors are 2σ). The NST30 biotite has different grain sizes of 30–40 mesh from the biotite (42–60 mesh) of TAGAMI et al. (1995). Both biotite separates are derived from the same rock. The K_2O and radiogenic ^{40}Ar of NST30 have been measured in Geological Survey of Japan and the K-Ar age is 21.0 ± 0.3 Ma (unpublished data). The K-Ar ages of duplicate analyses agree well with those of the unpublished data and TAGAMI et al. (1995).

As mentioned above, most K-Ar ages using the Ar analytical system in Kyoto University have been precisely obtained except a few cases. There also seems to be no systematic errors in the K-Ar ages. Therefore, precise and accurate K-Ar dating of volcanic or tectonic events of Neogene to Quaternary ages may be considered to be sufficiently possible.

5. Summary

The new Ar analytical system by sensitivity method of Kyoto University has been constructed and calibrated. K-Ar dating by sensitivity method is suitable for dating of Neogene to Quaternary volcanic and tectonic events. Calibration has been performed using Sori 93 in which the amount of radiogenic ^{40}Ar is known.

The system consists of VG Isotech 3600 mass spectrometer and the main sample handling system for the extraction of sample gases by tantalum resistance furnace and for the purification of them. The errors of ^{40}Ar intensity, $^{40}\text{Ar}/^{36}\text{Ar}$ and $^{38}\text{Ar}/^{36}\text{Ar}$ have been estimated by repeated standard air Ar analyses to be 1.5%, 0.16% and 0.53%, respectively.

The duplicate analyses have been performed to six K-Ar age mineral standards or K-Ar age known samples of Neogene to Quaternary ages. Obtained ages mostly agree well with those of literatures. There have been no systematic errors among them. The ages of four Neogene samples (Bern4B, Bern4M, Baba Tuff biotite and NST30 biotite) have been obtained within about $\pm 2-3\%$ errors and that of one Quaternary sample (YZ1) within about $\pm 25-30\%$ error. This implies that this Ar analytical system may be sufficiently useful for K-Ar dating of geological samples with younger ages than Neogene age.

Acknowledgements

We wish to express our grateful thanks to Drs. Kozo Uto and Akikazu Matsumoto of Geological Survey of Japan for their invaluable and practical advice to our geochronological laboratory and offering K-Ar age reference samples. Sincere thanks also go to Professors Kyoichi Ishizaka of Kyoto University and Kazuo Saito of Yamagata University for offering K-Ar age reference samples. We also acknowledge to Professors Jun-ichi Matsuda of Osaka University, Keisuke Nagao of Okayama University and Nobuo Takaoka of Kyushu University for many technical advice and teaching me important literatures. Thanks also go to Professors Masayuki Torii and Yoshiyuki Tatsumi and fission track geochronology group of Kyoto University for their support and encouragements.

Appendix

〈Correction of mass discrimination〉

$$({}^m\text{Ar}/{}^{m'}\text{Ar})_f = \frac{({}^m\text{Ar}/{}^{m'}\text{Ar})_{\text{cor.}} \cdot ({}^m\text{Ar}/{}^{m'}\text{Ar})_{\text{air}}}{({}^m\text{Ar}/{}^{m'}\text{Ar})_{\text{air m.}}}$$

$(^m\text{Ar}/^{m'}\text{Ar})_{\text{cor.}}$: $^m\text{Ar}/^{m'}\text{Ar}$ ratio of a sample when hot blank is corrected
 $(^m\text{Ar}/^{m'}\text{Ar})_{\text{air.}}$: $^m\text{Ar}/^{m'}\text{Ar}$ ratio of the atmosphere defined by Nier (1950)
 $(^m\text{Ar}/^{m'}\text{Ar})_{\text{air m.}}$: $^m\text{Ar}/^{m'}\text{Ar}$ ratio determined in air standard analysis
 $(^m\text{Ar}/^{m'}\text{Ar})_{\text{f.}}$: $^m\text{Ar}/^{m'}\text{Ar}$ ratio of a sample when mass discrimination is corrected

〈Error for correction of mass discrimination〉

$$\sigma_{(m/m')_{\text{f}}}^2 = \sigma_{(m/m')_{\text{cor.}}}^2 + \sigma_{(m/m')_{\text{air m.}}}^2$$

$\sigma_{(m/m')_{\text{cor.}}}$: Relatively error for $(^m\text{Ar}/^{m'}\text{Ar})_{\text{cor.}}$.

$\sigma_{(m/m')_{\text{air m.}}}$: Relatively error for $(^m\text{Ar}/^{m'}\text{Ar})_{\text{air m.}}$.

$\sigma_{(m/m')_{\text{f.}}}$: Relatively error for $(^m\text{Ar}/^{m'}\text{Ar})_{\text{f}}$

〈Correction of hot blank〉

$$(^{36}\text{Ar})_{\text{s}} = (^{40}\text{Ar})_{\text{s}} / (^{40}\text{Ar}/^{36}\text{Ar})_{\text{s}}$$

$$(^{38}\text{Ar})_{\text{s}} = (^{36}\text{Ar})_{\text{s}} \cdot (^{38}\text{Ar}/^{36}\text{Ar})_{\text{s}}$$

$$(^{36}\text{Ar})_{\text{b}} = (^{40}\text{Ar})_{\text{b}} / (^{40}\text{Ar}/^{36}\text{Ar})_{\text{b}}$$

$$(^{38}\text{Ar})_{\text{b}} = (^{36}\text{Ar})_{\text{b}} \cdot (^{38}\text{Ar}/^{36}\text{Ar})_{\text{b}}$$

$$(^m\text{Ar})_{\text{cor.}} = (^m\text{Ar})_{\text{s}} - (^m\text{Ar})_{\text{b}}$$

$$(^m\text{Ar}/^{m'}\text{Ar})_{\text{cor.}} = (^m\text{Ar})_{\text{cor.}} / (^{m'}\text{Ar})_{\text{cor.}}$$

m: Mass number

$(^m\text{Ar})_{\text{s}}$: Intensity of ^mAr determined in sample analysis

$(^m\text{Ar})_{\text{b}}$: Intensity of ^mAr determined in hot blank analysis

$(^m\text{Ar}/^{m'}\text{Ar})_{\text{s}}$: $^m\text{Ar}/^{m'}\text{Ar}$ ratio determined in sample analysis

$(^m\text{Ar}/^{m'}\text{Ar})_{\text{b}}$: $^m\text{Ar}/^{m'}\text{Ar}$ ratio determined in hot blank analysis

$(^m\text{Ar})_{\text{cor.}}$: Intensity of ^mAr in a sample when hot blank is corrected

$(^m\text{Ar}/^{m'}\text{Ar})_{\text{cor.}}$: $^m\text{Ar}/^{m'}\text{Ar}$ ratio of a sample when hot blank is corrected

〈Error for correction of hot blank〉

$$\sigma_{36\text{s}}^2 = \sigma_{40\text{s}}^2 + \sigma_{(40/36)\text{s}}^2$$

$$\sigma_{38\text{s}}^2 = \sigma_{36\text{s}}^2 + \sigma_{(38/36)\text{s}}^2$$

$$\sigma_{36\text{b}}^2 = \sigma_{40\text{b}}^2 + \sigma_{(40/36)\text{b}}^2$$

$$\sigma_{38\text{b}}^2 = \sigma_{36\text{b}}^2 + \sigma_{(38/36)\text{b}}^2$$

$$\sigma_{\text{mc}} = \frac{\{(^m\text{Ar}_{\text{s}} \cdot \sigma_{\text{ms}})^2 + (^m\text{Ar}_{\text{b}} \cdot \sigma_{\text{mb}})^2\}^{1/2}}{(^m\text{Ar}_{\text{s}} - ^m\text{Ar}_{\text{b}})}$$

$$\sigma_{(m/m')_{\text{c}}}^2 = \sigma_{\text{mc}}^2 + \sigma_{m'_{\text{c}}}^2$$

- σ_{ms} : Relative error for intensity of ${}^m\text{Ar}$ determined in sample analysis
 σ_{mb} : Relative error for intensity of ${}^m\text{Ar}$ determined in hot blank analysis
 $\sigma_{(m/m')s}$: Relative error for ${}^m\text{Ar}/{}^{m'}\text{Ar}$ ratio determined in sample analysis
 $\sigma_{(m/m')b}$: Relative error for ${}^m\text{Ar}/{}^{m'}\text{Ar}$ ratio determined in hot blank analysis
 ${}^m\text{Ar}_s$: Intensity of ${}^m\text{Ar}$ determined in sample analysis
 ${}^m\text{Ar}_b$: Intensity of ${}^m\text{Ar}$ determined in hot blank analysis
 σ_{mc} : Relative error for intensity of ${}^m\text{Ar}$ in a sample when hot blank is corrected
 $\sigma_{(m/m')c}$: Relative error for ${}^m\text{Ar}/{}^{m'}\text{Ar}$ ratio of a sample when hot blank is corrected

References

- DALRYMPLE, G. B. (1967) Potassium-argon ages of recent rhyolites of the Mono and Inyo Craters, California. *Earth Planet. Sci. Lett.*, **3**, 289–298
- DODSON, M. H. (1978) A linear method for second-degree interpolation in cyclical data collection. *J. Phys. E: Sci. Instrum.*, **11**, 296
- FLISCH, M. (1982) Potassium-argon analysis. *Numerical dating in stratigraphy*, ed. by Odin, G. S., Wiley and Sons, Chichester, 154–158
- HURFORD, A. J. and HAMMERSCHMIDT, K. (1985) ${}^{40}\text{Ar}/{}^{39}\text{Ar}$ and K/Ar dating of the Bishop and Fish Canyon Tuffs: Calibration ages for fission-track dating standards. *Chem. Geol.*, **58**, 23–32
- ITAYA, T., NAGAO, K., INOUE, K., HONJOU, Y., OKADA, T. and OGATA, A. (1991) Argon isotope analysis by a newly developed mass spectrometric system for K-Ar dating. *Mineral. J.*, **15**, 202–221
- JÄGER, E., NIGGLI, E. and BAETHGE, H. (1963) Two standard minerals, biotite and muscovite, for Rb-Sr and K-Ar age determinations, sample Bern4B and Bern4M from a gneiss from Brione. *Valle Verzasca. Schweiz. Min. Petr. Mitt.*, **43**, 465–470
- KANEOKA, I. (1980) Rare gas isotope and mass fractionation: An indicator of gas transport into or from a magma. *Earth Planet. Sci. Lett.*, **48**, 284–292
- Krummenacher, D. (1970) Isotopic composition of argon in modern surface volcanic rocks. *Earth Planet. Sci. Lett.*, **8**, 109–117
- MATSUMOTO, A. (1989) Improvement for determination of potassium in K-Ar dating (in Japanese with English abstract). *Bull. Geol. Surv. Japan*, **40**, 65–70
- MATSUMOTO, A., UTO, K. and SHIBATA, K. (1989a) Argon isotopic ratios in historic lavas -Importance of correction for the initial argon in K-Ar dating of young volcanic rocks- (in Japanese with English abstract). *Mass Spec.*, **37**, 353–363
- MATSUMOTO, A., UTO, K. and SHIBATA, K. (1989b) K-Ar dating by peak comparison method -New technique applicable to rocks younger than 0.5 Ma-. *Bull. Geol. Surv. Japan*, **40**, 565–579
- MATSUMOTO, A. (1990) K-Ar age determination for Quaternary volcanic rocks based on the mass fractionation correction method -Methodology and its application to Ontake and Aso Volcanoes-. Ph. D. Thesis, 153 pp., Univ. Tokyo, Tokyo.
- MATSUMOTO, A. and KOBAYASHI, T. (1995) K-Ar age determination of late Quaternary volcanic rocks using the “mass fractionation correction procedure”: application to the Younger Ontake Volcano, Central Japan. *Chem. Geol.*, **125**, 123–135
- MATSUMOTO, A. and UTO, K. (in prep.) Argon isotope ratios in recent volcanic rocks: Approach to accurate K-Ar ages of late Quaternary volcanic rocks.
- McDOUGALL, I. and HARRISON, T. M. (1988) *Geochronology and Thermochronology by the ${}^{40}\text{Ar}/{}^{39}\text{Ar}$ method*, Oxford Univ. Press, 42pp
- NAGAO, K. and ITAYA, T. (1988) K-Ar age determination (in Japanese with English abstract). *Mem. Geol. Soc. Japan*, **29**, 5–21
- NAGAO, K., OGATA, A., MIURA, Y., MATSUDA, J. and AKIMOTO, S. (1991) Highly reproducible 13 and 17 ka

- K-Ar ages of two volcanic rocks. *Geochem. J.*, **25**, 447–451
- NIER, A. O. (1950) A determination of the relative abundances of carbon, nitrogen, oxygen, argon, and potassium. *Phys. Rev.*, **77**, 789–793
- STEIGER, R. H. and JÄGER, E. (1977) Subcommittee on geochronology: convention on the use of decay constants in geo- and cosmochemistry. *Earth Planet. Sci. Lett.*, **36**, 359–362
- SUDO, M., ANNO, K., UTO, K., ISHIZUKA, O. and UCHIUMI, S. (in prep.) Preparation of a new biotite mineral standard, Sori 93, for the K-Ar dating method.
- TAKAHASHI, M., SAITO, K., UMETSU, H. and ICHIKAWA, N. (1992) K-Ar and ^{40}Ar - ^{39}Ar ages of the Miocene Kitamura and Baba Tuffs in the Tomioka area, Gunma Prefecture, central Japan -with special reference to the N.13/N.14 boundary of planktonic foraminiferal zones- (in Japanese with English abstract). *Jour. Geol. Soc. Japan*, **98**, 323–335
- TAKAOKA, N. (1988) Absolute age determination of volcanic rocks younger than 1 Ma (in Japanese), Report of the 1985–1987 Monbusyo Scientific Research Program, Proj. No. 60303011.
- TAKAOKA, N. (1989) Problems in the K-Ar dating of Quaternary volcanic rocks younger than 1 Ma (in Japanese with English abstract). *Mass Spec.*, **37**, 343–351
- TAKAOKA, N., KONNO, K., OBA, Y. and KONDA, T. (1989) K-Ar dating of lavas from Zao Volcano, North-eastern Japan (in Japanese with English abstract). *J. Geol. Soc. Japan*, **95**, 157–170
- TAGAMI, T., UTO, K., MATSUDA, T., HASEBE, N. and MATSUMOTO, A. (1995) K-Ar biotite and fission-track zircon ages of the Nisatai Dacite, Iwate Prefecture, Japan: A candidate for Tertiary age standard. *Geochem. J.*, **29**, 207–211
- UCHIUMI, S., UTO, K. and SHIBATA, K. (1989) K-Ar ages of rock reference materials. *Mass Spec.*, **37**, 375–381