

Systematic studies of  
two Japanese brown frogs

Koshiro ETO

2013





A calling male of Tago's brown frog, *Rana tagoi* (above) and an amplexant pair of Stream brown frog, *R. sakuraii* (below).



## CONTENTS

|                  | Page                                                                                                                                                           |    |
|------------------|----------------------------------------------------------------------------------------------------------------------------------------------------------------|----|
| Contents         |                                                                                                                                                                |    |
| Chapter 1        | Introduction                                                                                                                                                   | 1  |
| Chapter 2        | Highly Complex Mitochondrial DNA Genealogy in an Endemic Japanese Subterranean Breeding Brown Frog <i>Rana tagoi</i> (Amphibia, Anura, Ranidae)                | 4  |
| Chapter 3        | Discordance between Mitochondrial DNA Genealogy and Nuclear DNA Genetic Structure in the Two Morphotypes of <i>Rana tagoi tagoi</i> in the Kinki Region, Japan | 27 |
| Chapter 4        | Cytonuclear Discordance and Historical Demography of Two Brown Frogs <i>Rana tagoi</i> and <i>R. sakuraii</i>                                                  | 42 |
| Chapter 5        | General Discussion                                                                                                                                             | 75 |
| Summary          |                                                                                                                                                                | 79 |
| Acknowledgements |                                                                                                                                                                | 80 |
| References       |                                                                                                                                                                | 81 |
| Appendix         |                                                                                                                                                                | 91 |



## CHAPTER 1

### Introduction

As is well known, Mayr *et al.* (1953) recognized three levels (alpha, beta, and gamma) in the study of taxonomy, although they are mutually correlated and are not clear-cut. For Japanese amphibians, the alpha-level taxonomic studies started in the middle of 19<sup>th</sup> century (Temminck & Schlegel 1838), and through the later studies by authors like Stejneger (1907), Okada (1930), and Nakamura & Ueno (1963), basic species classification was established by the 1960s. Then the introduction of modern methodologies like molecular analyses enabled studies of relationships among species, i.e., beta taxonomy (Matsui 2000). Studies using allozymic techniques started over 30 years ago, and resulted in many findings related to taxonomy (e.g., Matsui & Miyazaki 1984; Matsui 1987, 1994; Matsui *et al.* 1992; Nishioka *et al.* 1987a, 1990). Later, the direct sequencing method was introduced in early 1990s, and molecular phylogenetic analysis using DNA sequences revealed inter-specific relationships of many Japanese and continental amphibians (Tanaka *et al.* 1994; Tanaka-Ueno *et al.* 1998). More recently, many studies also focus on the gamma taxonomy, which treats intra-specific variations, evolutionary history, and process of speciation (Mayr *et al.* 1953). Recent gamma level taxonomic studies revealed intra-specific diversity of several Japanese amphibians (e.g., Matsui *et al.* 2006a; Igawa *et al.* 2006; Yoshikawa *et al.* 2008), and some of them dealt with problems of cryptic species diversity (e.g., Nishikawa *et al.* 2007; Tominaga & Matsui 2008; Yoshikawa & Matsui 2013; Kuramoto *et al.* 2011; Sekiya *et al.* 2012).

*Rana tagoi* Okada 1928, endemic to Japan is very abundant in the montane regions of Honshu, Shikoku, and Kyushu. This species is a member of so-called brown frogs (Anura: Ranidae: *Rana*) that are distributed widely in the Holarctic region and have extended its range to a part of the Oriental region. Unlike the great majority of brown frogs that breed in the open, still waters, *R. tagoi* lays eggs in lotic environment of subterranean streams. This species is currently split into three subspecies, and the nominotypical subspecies (*R. t. tagoi*) is common and widespread throughout Japan excepting Hokkaido. However, intra-subspecific variations

of *R. t. tagoi* have been reported, and some more cryptic taxa are thought to be included in this subspecies (e.g., Sugahara 1990; Ryuzaki *et al.* 2006: see Chapter 2). On the other hand, *R. sakuraii* Matsui & Matsui 1990, a close relative of *R. tagoi*, occurs in Honshu and often sympatric with the latter species. *Rana sakuraii* breeds in open streams in contrast to subterranean breeding *R. tagoi*. Although *R. sakuraii* and *R. tagoi* differ in morphology and breeding ecology, genetic relationships of the two species is complicated, and *R. sakuraii* is included in *R. tagoi* on the mitochondrial genealogy (Tanaka *et al.* 1996). In spite of many previous studies on intra- and inter-specific variations of the two species, no comprehensive research has been conducted, and details of their variations, taxonomic relationships, and evolutionary history, are still unclear.

In this study, I conducted molecular phylogenetic and population genetic surveys on *R. tagoi* and *R. sakuraii* to assess their cryptic diversity and evolutionary history. First, in Chapter 2, I performed basic molecular phylogenetic analysis using samples of two species from their entire distributional ranges, and examined their genetic variations and phylogenetic patterns. Next, in Chapter 3, I focused on the two morphotypes of *R. tagoi* from the Kinki region (Sugahara 1990) and investigate their detailed genetic relationships using multiple genes to evaluate their taxonomic status. Finally in Chapter 4, I expanded the multilocus analysis to entire samples, and discussed the taxonomic relationships and evolutionary history of *R. tagoi* and *R. sakuraii*.

Of these chapters, Chapters 2 and 3 have been published in Zoological Science vol. 29 and 30, respectively. The remaining one, Chapter 4, is now under preparation for submission to an international journal.

## **Chapter 2:**

Eto K, Matsui M, Sugahara T, Tanaka-Ueno T (2012) Highly complex mitochondrial DNA genealogy in an endemic Japanese subterranean breeding brown frog *Rana tagoi* (Amphibia, Anura, Ranidae). *Zoological Science*, **29**, 662–671.



### **Chapter 3:**

Eto K, Matsui M, Sugahara T (2013) Discordance between mitochondrial DNA genealogy and nuclear DNA genetic structure in the two morphotypes of *Rana tagoi tagoi* (Amphibia: Anura: Ranidae) in the Kinki region, Japan. *Zoological Science*, **30**, 553–558.



## CHAPTER 2

### Highly Complex Mitochondrial DNA Genealogy in an Endemic Japanese Subterranean Breeding Brown Frog *Rana tagoi* (Amphibia, Anura, Ranidae)

#### 2-1 INTRODUCTION

The genus *Rana* historically represented a very large group of frogs that occurred almost worldwide (Boulenger 1920; Frost 1985; Dubois 1992), but is now restricted to smaller number of Holarctic brown frogs (Frost *et al.* 2006) that are generally similar in adult morphology and ecology. Most congeners breed in still (lentic) waters, such as ponds and rice paddies (e.g., *R. temporaria* Linnaeus 1758 from Europe: Nöllert & Nöllert 1992), and only a few (e.g., *R. graeca* Boulenger 1891 from Europe and *R. sauteri* Boulenger 1909 from Taiwan) in flowing (lotic) waters of open streams (Nöllert & Nöllert 1992; Tanaka-Ueno *et al.* 1998). Compared with such species, Japanese *R. tagoi* (type locality: restricted by Shibata [1988] to Kamitakara Village, currently included in Takayama City, Gifu Prefecture) is unique in that it breeds in small underground streams (Maeda & Matsui 1999). This subterranean breeding habit is highly specialized and is not known in any other congeneric species.

*Rana tagoi* is endemic to the main (Honshu, Shikoku, and Kyushu) and some adjacent, smaller (Yakushima, Oki, and Goto) islands of Japan. Eggs laid in subterranean streams are few in number and large in size, and once hatched tadpoles can metamorphose without feeding (Maeda & Matsui 1999). Such traits appear to be an adaptation to this unique breeding environment. Another brown frog, *R. sakuraii* (type locality: Okutama Town, Tokyo Prefecture) occurs only on Honshu Island and breeds in wider open streams in mountain regions. Other than the difference in breeding environment, this species is generally similar to *R. tagoi* in morphology and ecology, and is thought to be a close relative of *R. tagoi*, having originated from a *R. tagoi*-like subterranean breeding ancestor (Maeda & Matsui 1999).

Steep mountains that provide many streams and rivers occupy the larger part of the main islands of Japan. Reflecting this environmental trait, there are various amphibian species that are adapted to lotic environments (e.g., *Bufo torrenticola* Matsui 1976; *Buergeria buergeri*

[Temminck & Schlegel 1838]). Recent extensive surveys have revealed high cryptic diversity in some lotic breeding salamanders of the genera *Hynobius* and *Onychodactylus* (Nishikawa *et al.* 2007; Yoshikawa *et al.* 2008). A similar situation is expected in the case of lotic breeding *R. tagoi*, as the species is unique among Japanese frogs in that it contains three distinct subspecies (*R. t. tagoi* from main islands of Japan, *R. t. okiensis* Daito 1969 from Oki Islands, and *R. t. yakushimensis* Nakatani & Okada 1966 from Yakushima Island). In addition, morphological, breeding ecological (Sugahara 1990; Sugahara & Matsui 1992, 1993, 1994, 1995, 1996, 1997), and karyological variations reported within *R. t. tagoi* suggest that it includes cryptic species. Genetically, *R. tagoi* is also diversified as shown by the analyses of allozymes (Nishioka *et al.* 1987b) and mitochondrial DNA (mtDNA; Tanaka *et al.* 1994). In contrast, variations within *R. sakuraii* have been poorly studied.

These previous studies suggest the presence of phylogenetic and/or taxonomic problems in *R. tagoi*, while such information is lacking for *R. sakuraii*. To date, few studies (e.g., Ryuzaki *et al.* 2006) have compared a large number of samples from the entire distributional range of the two species, leaving the comprehensive patterns of intra- or inter-specific variations unresolved. In this chapter, I conducted a phylogenetic analysis using two mitochondrial genes, relatively conservative 16S ribosomal RNA (*16S*) and rapidly evolving NADH dehydrogenase subunit 1 (*ND1*; Mueller 2006), to reveal patterns of genetic differentiation and genealogical relationships in terms of mtDNA among samples of *R. tagoi* and *R. sakuraii*.

## **2-2 MATERIALS AND METHODS**

I collected 183 specimens of *R. t. tagoi*, including the topotypic population, from 145 localities covering its entire distributional range in Honshu, Shikoku, and Kyushu. The “large” and “small” types of *R. t. tagoi* from Kinki (Sugahara 1990) were distinguished according to the diagnosis of Sugahara & Matsui (1994). I also collected two specimens of *R. t. yakushimensis* from Yakushima Island and three specimens of *R. t. okiensis* from the Oki islands. Furthermore, I collected 19 specimens of *R. sakuraii*, including the topotype, from 16 localities in Honshu. Detailed sampling localities are shown in Fig. 2-1 and Table 2-1.

As outgroups, I used *R. tsushimensis* from Tsushima Islands, Japan, and *Lithobates sylvaticus* from Quebec, Canada. The latter species is morphologically and ecologically similar to members of the genus *Rana*, but has been placed recently in another ranid genus, *Lithobates* (Frost *et al.* 2006).

Total DNA was extracted from frozen or ethanol-preserved tissues by standard phenol-chloroform extraction procedures (Hillis *et al.* 1996). Fragments containing the entire *16S* and *ND1* sequences, approximately 2.9 kb long, were amplified by polymerase chain reaction (PCR). The PCR cycle included an initial heating at 94°C for 4 min; 33 cycles of 94°C (30 s), 50°C (30 s), and 72°C (2 min 30 s); and a final extension at 72°C for 7 min. The amplified PCR products were purified by polyethylene glycol (PEG) precipitation procedures. The cycle sequence reactions were carried out with ABI PRISM Big Dye Terminator v3.1 Cycle sequencing Kit (Applied Biosystems) and sequencing was performed on an ABI 3130 automated sequencer. I used the primers listed in Table 2-2 to amplify and sequence the fragments, and all samples were sequenced in both directions. The obtained sequences were deposited in GenBank (Table 2-1).

Sequences obtained were aligned using Clustal W (Thompson *et al.* 1994), and gaps and ambiguous areas were excluded from alignments using Gblocks 0.91b (Castresana 2000) with default settings. I then constructed phylogenetic trees from the combined alignments using maximum parsimony (MP), maximum likelihood (ML), and Bayesian inference (BI). The MP analysis was performed using PAUP\*4.0b10 (Swofford 2002). I used a heuristic search with the tree bisection and reconnection (TBR) branch-swapping algorithm and 100 random additions replicates, and the number of saved trees was restricted to 5,000. Transitions and transversions were equally weighted. The ML and BI analyses were respectively performed using TREEFINDER ver. Oct. 2008 (Jobb 2008) with Phylogears 1.5.2010.03.24 (Tanabe 2008) and MrBayes ver. 3.1.2 (Ronquist & Huelsenbeck 2003). Different substitution models were applied for each gene partition in both of the analyses. The optimum substitution model for each gene was selected by using Kakusan4 (Tanabe 2011), based on the Akaike information criterion (AIC). The best model was calculated for each codon position (1st, 2nd, and 3rd positions) of the *ND1* genes. In the BI analysis, two independent runs of four Markov chains were conducted for 7,000,000 generations (sampling frequency: one tree per 100

generations). I used TRACER v. 1.4 (Rambaut & Drummond 2009) to determine the burn-in size and when the log likelihood of sampled trees reached stationary distribution, and the first 7,001 trees were discarded (burn-in = 700,000).

The robustness of the MP and ML trees were tested using non-parametric bootstrap analysis (Felsenstein 1985) with 1000 replicates. I regarded tree topologies with bootstrap value (BS) 70% or greater as sufficiently supported (Huelsenbeck & Hillis 1993). For the BI, I regarded Bayesian posterior probability (BPP) 0.95 or greater as significant support (Huelsenbeck & Ronquist 2001; Leaché & Reeder 2002). Uncorrected p-distances for each gene were also calculated using PAUP\* ver. 4.0b10.

## **2-3 RESULTS**

### **2-3-1 Sequences and statistics**

I obtained complete *16S* (1625 bp long) and *ND1* (973 bp) sequences from 207 individuals and two outgroup taxa. After excluding gaps and ambiguous areas, a combined 2521 nucleotide sites, of which 624 were variable and 456 were parsimoniously informative (Table 2-3), were used for phylogenetic analysis. I detected 190 haplotypes within the ingroup, of which 168 were in *R. t. tagoi*, two in *R. t. yakushimensis*, three in *R. t. okiensis*, and 17 in *R. sakuraii*.

The MP analysis produced 5,000 equally most parsimonious trees ( $L = 2007$ ,  $CI = 0.519$ ,  $RI = 0.901$ ). For the ML analysis, the best substitution model of *16S* estimated by Kakusan 4 was J2 model with a Gamma (G) shape parameter. In *ND1*, Hasegawa-Kishino-Yano-1985 (HKY85) model + G, HKY85 + G, and J2 + G were selected for the 1st, 2nd, and 3rd codon positions, respectively. For the BI analysis, the general time reverse (GTR) model + G was selected for *16S*. In *ND1*, HKY85 + G, HKY85 + G, and GTR + G were selected for the 1st, 2nd, and 3rd codon positions, respectively. The likelihood values ( $-\ln L$ ) of the ML and BI trees were 14439.77 and 15102.97, respectively.

### **2-3-2 Phylogenetic relationships**

The ML and BI analyses yielded essentially identical topologies. The MP tree was also

similar to these, although support values tended to be lower. The BI tree is shown in Fig. 2-2. *Rana tagoi* and *R. sakuraii* formed a fully supported monophyletic group, but both were paraphyletic with respect to each other. The ingroup was divided into two major clades, Clade A (MP-BS = 79%, ML-BS = 83%, BPP = 0.99) and Clade B (98%, 87%, 1.00, respectively), with uncorrected p-distances of 2.1% to 3.9% in *I6S* and 4.9% to 8.5% in *NDI* between them. Each clade contained several subclades, some of which were further divided into two or three groups. Sequence divergences as measured by the mean uncorrected p-distances among these subclades and groups are shown in Table 2-4.

Clade A, which contained a subset of *R. t. tagoi*, *R. t. yakushimensis*, and *R. sakuraii* samples, was divided into nine subclades (Subclade A-1 to A-9). Subclade A-1 (94%, 98%, 1.00) contained *R. t. tagoi* samples from Tohoku, northern Chubu, and northern Kinki regions. This subclade was divided into two groups, Group A-1a (97%, 99%, 1.00) and A-1b (96%, 99%, 1.00), with sequence divergences of 0.9% to 1.9% in *I6S* and 3.3% to 4.9% in *NDI* between them.

Group A-1a contained *R. t. tagoi* from Tohoku, northern Chubu, and northeastern Kinki (localities 1 to 41), including topotypic samples (locality 33) and a part of the *R. t. tagoi* “large type” (Sugahara 1990) (locality 41). Except for samples from localities 11 to 13, which were divergent from the others, genetic variation within Group A-1a was small, despite its wide range of distribution. Group A-1b contained all samples of the *R. t. tagoi* “small type” from northern Kinki (localities 41 to 52). Within this group, genetic variation among haplotypes was significant, and four divergent subgroups were recognized.

Subclade A-2 (96%, 99%, 1.00) contained *R. t. tagoi* from Kanto region (localities 18 and 53 to 64) and was divided into two divergent groups. Interestingly, *R. sakuraii* from eastern Honshu (localities 20, 60, and 149 to 154), including topotypic samples (locality 151), was completely embedded in one of these groups. Within Subclade A-2, *R. sakuraii* was not much divergent from *R. t. tagoi* (0.8% to 1.3% in *I6S*; 1.3% to 3.0% in *NDI*).

Subclade A-3 (99 %, 99%, 1.00) contained *R. sakuraii* from western Honshu (localities 35, 44, 114, 123, and 155 to 158), and was divided into three groups. Subclades A-2 and A-3 tended to form a clade, but their monophyly was not supported (< 50%, 66%, 0.86).

Subclade A-4 contained only one sample of *R. t. tagoi* from Nakanojo Town (former

Kuni Village), Gunma (locality 65), while Subclade A-5 (78%, 75%, 1.00) contained divergent haplotypes of *R. t. tagoi* from central Chubu (localities 66 to 68). Subclade A-6 (all 100%, or 1.00) contained *R. t. tagoi* from southern Chubu (localities 69 to 77) and Shima Peninsula (locality 78), where variation among haplotypes was small. This subclade included *R. t. tagoi* with  $2n = 28$  chromosomes (vs.  $2n = 26$  chromosomes in *R. t. tagoi* samples from other localities so far studied) from Neba Village, Nagano (Ryuzaki *et al.* 2006; locality 76). Subclades A-4 to A-6 tended to form a clade, but their monophyly was not unambiguously supported (< 50%, 68%, 1.00). Subclades A-1 to A-6 also tended to form a clade, but the MP support of this node was low (< 50%, 77%, 1.00).

Subclade A-7 (99%, 99%, 1.00) contained *R. t. tagoi* from Shikoku (localities 80 to 86) and Awaji Island (locality 79), with small genetic variations within the group. Subclade A-8 (all 100%, or 1.00) contained *R. t. yakushimensis* from Yakushima Island (locality 146), and was close to Subclade A-7, although their monophyly was not supported (< 50%, 63%, 0.54).

Subclade A-9 (90%, 99%, 1.00) contained *R. t. tagoi* from Kyushu and tended to form a clade with A-7 and A-8 but their monophyly was not supported (< 50%, 66%, 0.98). Subclade A-9 was divided into three groups, Groups A-9a (99%, 100%, 1.00), A-9b (93%, 94%, 1.00), and A-9c (only one sample) with divergences between them being 1.3% to 1.7% in 16S, and 2.9% to 3.2% in *NDI*. Group A-9a contained samples from northwestern Kyushu (localities 87 to 103), and genetic variation within the group was small. Group A-9b consisted of samples from southern Pacific side of the island (localities 104 to 110) and was divided into two subgroups. Group A-9c contained one sample from Narujima Island (locality 111).

Clade B contained *R. t. okiensis* and a part of *R. t. tagoi* samples, and was divided into two subclades. One of them, Subclade B-1 (all 100% or 1.00) contained *R. t. okiensis* from Oki islands (localities 147 and 148), while another, Subclade B-2 (99%, 95%, 1.00), consisted of *R. t. tagoi* from western Honshu. Two groups, with divergences of 0.8% to 1.6% in 16S and 2.1% to 4.0% in *NDI*, were recognized within this subclade; Group B-2a (99%, 95%, 1.00) and Group B-2b (88%, 69%, 1.00). Group B-2a contained samples from Kinki (localities 42 to 48, 50, and 112 to 135) and was divided into three subgroups. A large portion of the *R. t. tagoi* “large type” (Sugahara, 1990) samples (localities 42 to 48 and 50) was included in this group. Group B-2b contained samples from Chugoku (localities 136 to 145) and was divided into two



subgroups.

### 2-3-3 Geographic distribution of genetic groups

Genetic groups recognized in two major clades of *R. tagoi* (sensu lato) and *R. sakuraii* (totally 15 subclades/groups) showed a complex pattern of geographic distribution, with sympatric or parapatric occurrence in some (Figs. 2-1, 2-3 and Table 2-4). Only *R. t. yakushimensis* (A-8), *R. t. okiensis* (B-1), *R. t. tagoi* from Awaji Island and Shikoku (A-7), and *R. t. tagoi* from Kyushu (A-9a, b, and c) were allopatric from the other genetic groups, although A-9a and A-9b were parapatric within Kyushu.

*Rana t. tagoi* Group A-1a was widely distributed throughout northeastern Honshu to the northern part of central Honshu. It was transposed by *R. t. tagoi* Groups A-1b and B-2a in northeastern Kinki, the westernmost area of its distributional range. Group A-1a and A-1b were parapatric, with the exception of one sympatric site (locality 41). Group A-1b was distributed in northern part of Kinki, and was sympatric with B-2a in almost all ranges of its distribution (localities 42 to 48 and 50).

Group A-1a transposed by *R. t. tagoi* in Subclade A-2 in northern Kanto. They were mostly parapatric, but were sympatric in one site (locality 18). *Rana t. tagoi* in Subclade A-2 was replaced by Subclade A-6 (southern Chubu) in western Kanto. Subclades A-4 and A-5 occurred in northwestern Kanto to central Chubu, between Group A-1a in the Sea of Japan side and Subclade A-6 in the Pacific side. Subclade A-4 was sympatric with A-1a, and A-5 also seemed to overlap with A-1a. Subclade A-6 widely occurred covering southern Chubu, and was replaced by Group B-2a in the Shima Peninsula (locality 78).

Group B-2a of *R. t. tagoi* from Kinki, which was sympatric with the *R. t. tagoi* “small type” (A-1b) as shown above, was transposed in the west by B-2b, which widely occurred in Chugoku, western Honshu.

*Rana sakuraii* was divided into two genetic groups, eastern (A-2) and western (A-3) subclades. In western Kanto, *R. sakuraii* was sympatric with *R. t. tagoi* and together formed Subclade A-2. Also, in the northern part of its distribution, *R. sakuraii* in Subclade A-2 was sympatric with *R. t. tagoi* A-1a (locality 20) and parapatric with A-4 (localities 160 and 67), and furthermore, seemed to overlap with A-5 in central Chubu. Subclade A-2 was transposed

by *R. sakuraii* Subclade A-3 in the most western range of its distribution. Subclade A-3 largely overlapped with *R. t. tagoi* genetic groups in western Honshu (e.g., A-5, A-6, and B-2b), and sympatric with A-1a (locality 35), A-1b (locality 44), and B-2a (localities 44 and 114).

## **2-4 DISCUSSION**

### **2-4-1 Phylogenetic relationships and genetic differentiation**

Using allozymes and proteins, Nishioka *et al.* (1987b) constructed a phenogram in which *R. t. yakushimensis* (A-8 in this study) was shown to be divergent from *R. t. tagoi* from western Japan. Within the latter, populations from Kinki (B-2a), Chugoku (B-2b), and Shikoku (A-7) formed one group, and those from Kyushu (A-9a) and *R. t. okiensis* (B-1) formed another. These results are completely discordant with results obtained by us or by Tanaka *et al.* (1996) from the mitochondrial *cyt b* gene. Present results showed common features with those reported by Tanaka *et al.* (1994, 1996: i.e., paraphyly of *R. tagoi*; large differentiation between the “large” [B-2a] and “small” [A-1b] types of *R. t. tagoi* from Kyoto). Although there are superficial differences between Tanaka *et al.* (1994, 1996) and the present study, in the relationships of *R. t. tagoi*, *R. t. yakushimensis*, and *R. t. okiensis*, such discrepancies surely resulted from insufficient sampling in the Tanaka *et al.* (1994, 1996) study (e.g., Tanaka *et al.* [1996] used seven samples from five localities of *R. t. tagoi*, one sample of *R. t. yakushimensis*, three samples of *R. t. okiensis*, and six samples from three localities of *R. sakuraii*), and results obtained from mtDNA analyses are considered essentially similar.

Discordance between trees based on nuclear (i.e., allozymes) and mitochondrial markers is generally explained by the paralogy of genes, introgressive hybridization, and incomplete lineage sorting with ancestral polymorphism (Ballard & Whitlock 2004). However, these factors are difficult to differentiate without additional studies, in which nuclear marker analyses are made on the samples used in the present mtDNA analysis. In contrast to mitochondrial genes, allozymes are of limited value in estimating phylogenies, as historical relationships among alleles remain unclear (Avice 2000). Thus, phylogenetic trees based on mitochondrial genes should be more valid than the allozymic ones, although the possibility of mitochondrial gene introgression, which leads to a strongly biased gene tree, is not precluded.

The geographic pattern of genetic differentiations obtained for *R. tagoi* is quite unique among Japanese anurans in that samples from western Honshu (Clade B) first diverge from the others (Clade A). In wide-ranging Japanese anurans (e.g., *Bufo japonicus*: Matsui 1984; Igawa *et al.* 2006; *R. japonica*: Sumida & Ogata 1998; *R. rugosa*: Sekiya *et al.* 2010; *Buergeria buergeri*: Nishizawa *et al.* 2011), populations from western Honshu and those from Shikoku and Kyushu tend to form a clade, unlike in *R. tagoi*, in which populations from eastern to central Honshu, Shikoku, and Kyushu form a clade (Clade A). This unique distribution suggests that geographical and environmental factors that separated Clades A and B of *R. tagoi* differ from those that affected the distribution of other Japanese anurans. Present results do not contradict Matsui & Matsui's (1990) hypothesis that the probable common ancestor of *R. tagoi* and *R. sakuraii* would have a habit of subterranean breeding, which is quite unique among Japanese anurans. The availability of subterranean environments, which was not so critical in other anurans, may have been a major factor that caused population fragmentation and subsequent genetic divergence in the ancestor of *R. tagoi* and *R. sakuraii*.

The current wider distribution of Clade A compared to Clade B indicates the Clade A ancestor was dominant throughout Honshu, including Kinki and Chugoku, in the past, whereas Clade B now predominates. Later, ancestral Clade B appears to have arisen somewhere in western Honshu and expanded its range towards east while affecting Clade A by exclusion through competition, and/or causing gene introgression to lose its original haplotypes. *Rana sakuraii* and the “small type” of *R. t. tagoi* are sympatric with, and specifically distinct from Clade B in Kinki and Chugoku. It is possible that these two groups have already sufficiently differentiated ecologically to avoid competition or introgressive hybridization with Clade B for coexistence in these regions.

#### **2-4-2 Taxonomic relationships**

Of the many genetic groups recognized, Group A-1a should be considered true *R. t. tagoi* as it included the topotypic population from Kamitakara of the current Takayama City (locality 33), Gifu (Okada 1928; Shibata 1988). The “small type” of *R. t. tagoi*, one of the two types of *R. t. tagoi* from Kinki (Sugahara 1990), represented Group A-1b and was sympatric with the “large type” (parts of A-1a and B-2a). The “small type” differs from the “large type”

in morphological, acoustic, and breeding ecological traits (Sugahara 1990; Sugahara & Matsui 1992, 1993, 1994, 1995, 1996, 1997). Thus, *R. t. tagoi* “small type” (A-1b) should be regarded as a distinct species. In contrast, *R. t. tagoi* morphologically identified as the “large type” was placed in two genetic groups (A-1a and B-2a), both with samples from the regions other than Kinki, and its taxonomic status is still unclear.

Subclade A-4 from one locality in Chubu has a unique breeding ecology and morphology different from sympatric Group A-1a (Misawa, private communication) and would be a distinct species. *Rana t. tagoi* from Neba Village, Nagano, in Subclade A6 could also be another distinct species as it has  $2n = 28$  chromosomes in contrast to  $2n = 26$  in other *R. tagoi* and *R. sakurarii* populations (Ryuzaki *et al.* 2006). In the resultant tree, however, samples from Neba Village (locality 76) were very close to and formed Subclade A6 with *R. t. tagoi* from southern Chubu and Shima Peninsula. It is thus necessary to investigate the chromosome number of the other populations in A-6 to determine taxonomic status of the Neba Village population.

Details of morphological and ecological variations among other genetic groups of *R. t. tagoi* are generally poorly studied. Most of them are generally too similar to distinguish morphologically, but there are some exceptions. For example, representatives of Group A-1a and *R. t. tagoi* in Subclade A-2, at their range of sympatry in northern Kanto, are morphologically differentiated although slightly (Eto *et al.* unpublished data). Thus *R. t. tagoi* seems to include more cryptic taxa than previously suggested.

*Rana t. yakushimensis* formed Subclade A-8 by itself, and was split from the other *R. tagoi* subspecies and *R. sakurarii*. This result suggests its specific, rather than subspecific status, although it is morphologically very similar to *R. t. tagoi* (Maeda & Matsui 1999). Supporting this idea, Nishioka *et al.* (1987b) reported that *R. t. yakushimensis* was slightly isolated from *R. t. tagoi* from Chugoku (B-2b) by a low degree of hybrid inviability.

Another subspecies, *R. t. okiensis* also formed a distinct subclade (B-1) and split from other genetic groups. This subspecies is morphologically distinct from the other subspecies of *R. tagoi* and *R. sakurarii* (Maeda & Matsui 1999), and there is little doubt to treat it as a distinct taxon. Conlon *et al.* (2010) suggested *R. t. okiensis* and *R. t. tagoi* to be heterospecific from antimicrobial peptide structure, and Nishioka *et al.* (1987b) and Daito *et al.* (1998b) reported

postmating isolation of the two subspecies. These previous studies and present result strongly suggest that *R. t. okiensis* should be treated as a species distinct from *R. t. tagoi*.

The phylogenetic relationships obtained, in which *R. tagoi* and *R. sakurii* are revealed to be paraphyletic, are in disagreement with current taxonomy. This result may be partly due to imperfect taxonomy (i.e., insufficient detection of cryptic species), in addition to the evolutionary processes as mentioned above. *Rana sakurii* was divided into two genetic groups (Subclades A-2 and A-3). Of these, Subclade A-2 includes topotypic samples and should be regarded as true *R. sakurii*, in spite of the possibility of past gene introgression from *R. t. tagoi* as discussed above. Although both subclades of *R. sakurii* are sympatric with some genetic groups of *R. t. tagoi* in Honshu (Table 2-4), the two species are known to be reproductively isolated by differences in the season, site, and behavior of breeding (Maeda & Matsui 1999). Moreover, *R. sakurii* in A-2 is completely isolated from *R. t. tagoi* from Kinki (“large type” from Kyoto: B-2a) and *R. t. okiensis* (B-1) by post-mating isolating mechanisms (Daito *et al.* 1998a; Daito 1999). Because no obvious morphological and ecological differences have been detected between the two genetic groups of *R. sakurii*, it seems safe at present to retain it as a single species.

It is now popular to regard uncorrected p-distances in *16S* of 3–5% to be thresholds between intra- and inter-specific divergence levels in anurans (Vences *et al.* 2005; Fouquet *et al.* 2007). However, Hillis & Wilcox (2005) reported interspecific sequence divergences of *16S* among American ranid frogs to be 1.2–18.7% (uncorrected p-distances calculated from GenBank data). Thus, sequence divergence alone is not an absolute indicator to draw taxonomic conclusions, though it can be considered useful in detecting candidate species. As to *ND1*, Vredenburg *et al.* (2007) separated *R. sierrae* and *R. muscosa*, with 4.6% sequence divergence in *ND1* and *ND2*, as distinct species.

In the light of these reports, divergences among genetic groups of *R. tagoi* and *R. sakurii* (1.3–3.5% in *16S* and 2.9–7.0% in *ND1*) are generally not very large. Of the cryptic lineages discussed above, A-1b (the “small type”) could be regarded as heterospecific with B-2a (the “large type”: divergences of 3.2% in *16S* and 6.7% in *ND1*), although its divergence from true *R. t. tagoi* (A-1a) is not large enough to indicate specific separation (1.3% and 4.1%). Of other unique groups observed, Subclade A6, including a population with extra number of

chromosomes, differed from the other groups by divergences of 1.5–3.3% (*I6S*) and 3.4–6.7% (*ND1*). Likewise, divergences were 1.8–3.3% and 4.1–6.4% between *R. t. okiensis* and the other groups, and 1.5–2.8% and 2.8–6.9% between *R. t. yakushimensis* and the other groups. These values partly exceed proposed thresholds or reported values for specific separation (Fouquet *et al.* 2007; Vredenburg *et al.* 2007). Other combinations produced even smaller divergences (1.4% and 3.9% between Subclade A-4 and Group A-1a; 1.7% and 4.0% between Group A-1a and *R. t. tagoi* in Subclade A-2; and 1.1% and 2.1% between *R. sakurarii* and *R. t. tagoi* in A-2), in spite of their sympatric occurrences, and posed questions about the universality of threshold values in DNA barcoding.

In frogs, sister species sometimes exhibit very small sequence divergences in spite of their distinct morphological and/or ecological differences (e.g., Matsui *et al.* 2006b), and similar situations appear to apply to unique genetic groups recognized in *R. tagoi* and *R. sakurarii*. Small sequence divergences, like morphological and ecological similarities, suggest relatively recent separation among genetic groups of these frogs.

This study provided a large amount of new information about the complex genetic diversity and consequential taxonomic problems with respect to *R. tagoi* and *R. sakurarii*. However, mtDNA alone is not a conclusive indicator of reproductive isolation, due to its maternal mode of inheritance. Thus in the following chapters, I also analyzed nuclear DNA markers to clarify the reproductive isolation among genetic groups and detailed evolutionary history.

## FIGURE LEGENDS

**Fig. 2-1.** Map of Japan showing sampling localities of *Rana t. tagoi* (circles), *R. t. yakushimensis* (double circle), *R. t. okiensis* (stars), and *R. sakuraii* (triangles). Squares indicate localities with sympatry of *R. t. tagoi* and *R. sakuraii*. For names of localities and genetic groups, see Table 2-1.

**Fig. 2-2.** Bayesian tree of total *16S* and *ND1* mitochondrial genes for three subspecies of *R. tagoi*, *R. sakuraii*, and outgroup taxa. Nodal values indicate bootstrap supports for MP and ML, and Bayesian posterior probability (MP-BS/ML-BS/BPP). Asterisks indicate nodes with MP-BS and ML-BS = 70% and BPP = 0.95. For locality numbers, see Table 2-1 and Fig. 2-1.

**Fig. 2-3.** Distributional range of each genetic group of *Rana tagoi* (solid line) and *R. sakuraii* (dotted line). For names of genetic groups, see Table 2-1 and Fig. 2-2.





**Table 2-1.** Samples used for mtDNA analysis in this study with the information of voucher and collection locality. KUHE: Graduate School of Human and Environmental Studies, Kyoto University; TMP: Temporary numbered; UN: Unnumbered.

| Sample no               | Locality                            | genetic group | Voucher (KUHE) | GenBank    |            |
|-------------------------|-------------------------------------|---------------|----------------|------------|------------|
|                         |                                     |               |                | <i>16S</i> | <i>ND1</i> |
| <i>Rana tagoi tagoi</i> |                                     |               |                |            |            |
| 1                       | Mutsu City, Aomori Pref.            | A-1a          | 44827          | AB639413   | AB639593   |
| 2                       | Goshogawara City, Aomori Pref.      | A-1a          | 36949          | AB639413   | AB639594   |
| 3                       | Towada City, Akita Pref             | A-1a          | 13932          | AB639413   | AB639603   |
| 4                       | Noda Village, Iwate Pref.           | A-1a          | 37028          | AB639413   | AB639595   |
| 5                       | Kamaishi City, Iwate Pref.          | A-1a          | 27750          | AB639411   | AB639596   |
| 6                       | Oshu City, Iwate Pref.              | A-1a          | 32889          | AB639413   | AB639597   |
| 7                       | Ichinoseki City, Iwate Pref.        | A-1a          | 35268          | AB639412   | AB639603   |
| 8                       | Fujisawa Town, Iwate Pref.          | A-1a          | 36699          | AB639413   | AB639598   |
| 9                       | Senboku City, Akita Pref.           | A-1a          | 27351          | AB639413   | AB639603   |
| 10                      | Ishinomaki City, Miyagi Pref.       | A-1a          | 41545          | AB639414   | AB639603   |
| 11                      | Sendai City, Miyagi Pref.           | A-1a          | 37121          | AB639415   | AB639599   |
| 12                      | Sakata City, Yamagata Pref.         | A-1a          | 37544          | AB639416   | AB639600   |
| 13                      | Yamagata City, Yamagata Pref.       | A-1a          | 37543          | AB639417   | AB639601   |
| 14                      | Kaminoyama City, Yamagata Pref.     | A-1a          | 29360          | AB639420   | AB639602   |
| 15                      | Nishikawa Town, Yamagata Pref.      | A-1a          | 37548          | AB639418   | AB639603   |
| 16                      | Nihonmatsu City, Fukushima Pref.    | A-1a          | 29595          | AB639419   | AB639604   |
| 17                      | Shirakawa City, Fukushima Pref.     | A-1a          | 21629          | AB639420   | AB639605   |
| 18a                     | Daigo Town, Ibaraki Pref.           | A-1a          | 42344          | AB639420   | AB639605   |
| 18b                     |                                     | A-2           | 43886          | AB639421   | AB639646   |
| 19                      | Nikko City, Tochigi Pref.           | A-1a          | 36719          | AB639426   | AB639609   |
| 20a                     | Kanuma City, Tochigi Pref.          | A-1a          | 40166          | AB639422   | AB639609   |
| 21                      | Minakami Town, Gunma Pref.          | A-1a          | 27539          | AB639429   | AB639612   |
| 22                      | Nakanojo Town, Gunma Pref.          | A-1a          | 27930          | AB639424   | AB639606   |
| 23                      | Shibukawa City, Gunma Pref.         | A-1a          | 29485          | AB639425   | AB639607   |
| 24                      | Agano City, Niigata Pref.           | A-1a          | 29600          | AB639426   | AB639608   |
| 25                      | Aga Town, Niigata Pref.             | A-1a          | UN             | AB639426   | AB639609   |
| 26                      | Yahiko Village, Niigata Pref.       | A-1a          | 27765          | AB639427   | AB639610   |
| 27                      | Kashiwazaki City, Niigata Pref.     | A-1a          | 36892          | AB639428   | AB639611   |
| 28                      | Uonuma City, Niigata Pref.          | A-1a          | 36896          | AB639429   | AB639612   |
| 29                      | Otari Village, Nagano Pref.         | A-1a          | 43367          | AB639430   | AB639613   |
| 30                      | Ueda City, Nagano Pref.             | A-1a          | 18752          | AB639431   | AB639614   |
| 31                      | Kiso Town, Nagano Pref.             | A-1a          | 43382          | AB639432   | AB639615   |
| 32                      | Hodatsushimizu Town, Ishikawa Pref. | A-1a          | 41053          | AB639433   | AB639616   |
| 33                      | Takayama City, Gifu Pref.           | A-1a          | 27613, 43018   | AB639434   | AB639617   |
| 34                      | Shirakawa Village, Gifu Pref.       | A-1a          | 26104          | AB639435   | AB639618   |
| 35a                     | Ibigawa Town, Gifu Pref.            | A-1a          | 27388          | AB639436   | AB639619   |
| 36                      | Ikeda Town, Fukui Pref.             | A-1a          | 40441          | AB639438   | AB639624   |
| 37                      | Nagahama City, Shiga Pref.          | A-1a          | 41470, 41471   | AB639439   | AB639621   |
| 38                      | Maibara City, Shiga Pref.           | A-1a          | 37610, 37614   | AB639440   | AB639622   |
| 39a                     | Taga Town, Shiga Pref.              | A-1a          | 41287          | AB639440   | AB639622   |
| 39b                     |                                     |               | 41551          | AB639441   | AB639623   |
| 40                      | Nagahama City, Shiga Pref.          | A-1a          | 40385          | AB639442   | AB639624   |
| 41a                     | Takashima City, Shiga Pref.         | A-1a          | TMP_T3395      | AB639443   | AB639625   |
| 41b                     |                                     |               | 40437          | AB639444   | AB639625   |
| 41c                     |                                     |               | TMP_T3402      | AB639445   | AB639625   |
| 41d                     |                                     | A-1b          | TMP_T3392      | AB639446   | AB639626   |
| 42a                     | Takashima City, Shiga Pref.         | A-1b          | 25993          | AB639447   | AB639627   |
| 42b                     |                                     | B-2a          | 43609          | AB639448   | AB639711   |
| 42c                     |                                     | B-2a          | 25996          | AB639453   | AB639711   |

Table 2-1. Continued.

|     |                                       |      |              |          |          |
|-----|---------------------------------------|------|--------------|----------|----------|
| 43a | Otsu City, Shiga Pref.                | A-1b | 41414, 43428 | AB639449 | AB639628 |
| 43b |                                       | B-2a | 41090        | AB639450 | AB639629 |
| 43c |                                       |      | 43148        | AB639451 | AB639713 |
| 44a | Nantan City, Kyoto Pref.              | A-1b | 41408        | AB639452 | AB639630 |
| 44b |                                       | B-2a | 41406        | AB639453 | AB639711 |
| 44c |                                       |      | 41426        | AB639547 | AB639713 |
| 45a | Kyoto City, Kyoto Pref.               | A-1b | 43324        | AB639457 | AB639635 |
| 45b |                                       | B-2a | 41730        | AB639458 | AB639633 |
| 45c |                                       |      | 38698        | AB639459 | AB639634 |
| 46a | Kyoto City, Kyoto Pref.               | A-1b | 42034, 44828 | AB639460 | AB639635 |
| 46b |                                       | B-2a | 44835        | AB639462 | AB639711 |
| 46c |                                       |      | 42396        | AB639463 | AB639711 |
| 46d |                                       |      | 41439        | AB639461 | AB639713 |
| 46e |                                       |      | 42319        | AB639464 | AB639712 |
| 47a | Toyooka City, Hyogo Pref.             | A-1b | 25664        | AB639465 | AB639636 |
| 47b |                                       | B-2a | 25662        | AB639564 | AB639729 |
| 48a | Toyooka City, Hyogo Pref.             | A-1b | 42711        | AB639466 | AB639637 |
| 48b |                                       | B-2a | 42714        | AB639467 | AB639729 |
| 49a | Sasayama City, Hyogo Pref.            | A-1b | 10285        | AB639468 | AB639638 |
| 49b |                                       |      | 10307        | AB639469 | AB639639 |
| 50a | Asago City, Hyogo Pref.               | A-1b | 10319        | AB639470 | AB639642 |
| 50b |                                       | B-2a | 36586        | AB639471 | AB639640 |
| 51  | Kobe City, Hyogo Pref.                | A-1b | 22647        | AB639472 | AB639641 |
| 52  | Wakasa Town, Tottori Pref.            | A-1b | 34743        | AB639473 | AB639642 |
| 53  | Nihonmatsu City, Fukushima Pref.      | A-2  | 36330        | AB639474 | AB639643 |
| 54  | Hirono Town, Fukushima Pref.          | A-2  | 44829        | AB639475 | AB639644 |
| 55  | Kitaibaraki City, Ibaraki Pref.       | A-2  | 27544        | AB639476 | AB639645 |
| 56  | Hitachi City, Ibaraki Pref.           | A-2  | 27550        | AB639477 | AB639646 |
| 57  | Hitachiomiya City, Ibaraki Pref.      | A-2  | 43711        | AB639478 | AB639647 |
| 58a | Tsukuba City, Ibaraki Pref.           | A-2  | 42747        | AB639479 | AB639648 |
| 58b |                                       |      | 42751        | AB639480 | AB639649 |
| 59  | Mashiko Town, Tochigi Pref.           | A-2  | 25968        | AB639481 | AB639650 |
| 60a | Akiruno City, Tokyo Pref.             | A-2  | 42452        | AB639483 | AB639651 |
| 61  | Ichihara City, Chiba Pref.            | A-2  | 28409        | AB639482 | AB639652 |
| 62  | Otsuki City, Yamanashi Pref.          | A-2  | 28064        | AB639483 | AB639653 |
| 63a | Izu City, Shizuoka Pref.              | A-2  | 36715        | AB639484 | AB639654 |
| 63b |                                       |      | 43468        | AB639485 | AB639655 |
| 64  | Fuji City, Shizuoka Pref.             | A-2  | 43473        | AB639486 | AB639656 |
| 65  | Nakanojo Town, Gunma Pref.            | A-4  | 22930, 22936 | AB639487 | AB639657 |
| 66  | Nagano City, Nagano Pref.             | A-5  | 18005        | AB639488 | AB639658 |
| 67  | Hokuto City, Yamanashi Pref.          | A-5  | 43483        | AB639489 | AB639659 |
| 68a | Gujo City, Gifu Pref.                 | A-5  | 14228        | AB639490 | AB639660 |
| 68b |                                       |      | 44832        | AB639491 | AB639661 |
| 69  | Hayakawa Town, Yamanashi Pref.        | A-6  | 14208        | AB639492 | AB639662 |
| 70  | Fujikawaguchiko Town, Yamanashi Pref. | A-6  | 43480        | AB639493 | AB639663 |
| 71a | Shizuoka City, Shizuoka Pref.         | A-6  | 42977        | AB639494 | AB639664 |
| 71b |                                       |      | 24561        | AB639495 | AB639665 |
| 72  | Shizuoka City, Shizuoka Pref.         | A-6  | 29933        | AB639496 | AB639666 |
| 73  | Kawanehon Town, Shizuoka Pref.        | A-6  | 42270        | AB639497 | AB639667 |
| 74  | Fujieda City, Shizuoka Pref.          | A-6  | 17955        | AB639498 | AB639668 |
| 75  | Takegawa City, Shizuoka Pref.         | A-6  | 39980        | AB639499 | AB639669 |
| 76  | Neba Village, Nagano Pref.            | A-6  | 27335        | AB639500 | AB639670 |
| 77  | Shitara Town, Aichi Pref.             | A-6  | 27251        | AB639501 | AB639671 |

Table 2-1. Continued.

|      |                                 |      |              |          |          |
|------|---------------------------------|------|--------------|----------|----------|
| 78a  | Ise City, Mie Pref.             | A-6  | 42829        | AB639502 | AB639672 |
| 78b  |                                 |      | 42830        | AB639503 | AB639672 |
| 79   | Minamiawaji City, Hyogo Pref.   | A-7  | 43885        | AB639504 | AB639673 |
| 80   | Manno Town, Kagawa Pref.        | A-7  | TMP_T2882    | AB639505 | AB639674 |
| 81   | Kamiyama Town, Tokushima Pref.  | A-7  | TMP_T2876    | AB639506 | AB639675 |
| 82   | Saijo City, Ehime Pref.         | A-7  | 27679        | AB639507 | AB639676 |
| 83   | Imabari City, Ehime Pref.       | A-7  | 27506        | AB639508 | AB639677 |
| 84   | Seiyo City, Ehime Pref.         | A-7  | TMP_T2241    | AB639509 | AB639678 |
| 85   | Toyo Town, Kochi Pref.          | A-7  | 29464        | AB639510 | AB639679 |
| 86   | Kochi City, Kochi Pref.         | A-7  | 36184        | AB639511 | AB639680 |
| 87   | Kitakyushu City, Fukuoka Pref.  | A-9a | 28614        | AB639512 | AB639681 |
| 88   | Koga City, Fukuoka Pref.        | A-9a | 26841        | AB639513 | AB639682 |
| 89   | Fukuoka City, Fukuoka Pref.     | A-9a | 26238        | AB639514 | AB639683 |
| 90   | Yame City, Fukuoka Pref.        | A-9a | 26643        | AB639515 | AB639684 |
| 91   | Asakura City, Fukuoka Pref.     | A-9a | 27137        | AB639516 | AB639685 |
| 92   | Isahaya City, Nagasaki Pref.    | A-9a | 9660         | AB639517 | AB639686 |
| 93   | Sasebo City, Nagasaki Pref.     | A-9a | 27140        | AB639518 | AB639687 |
| 94   | Beppu City, Oita Pref.          | A-9a | 43637        | AB639519 | AB639688 |
| 95   | Bungo-ohno City, Oita Pref.     | A-9a | 27146        | AB639520 | AB639694 |
| 96   | Kokonoe Town, Oita Pref.        | A-9a | 26148        | AB639521 | AB639689 |
| 97   | Gokase Town, Miyazaki Pref.     | A-9a | 44834        | AB639522 | AB639690 |
| 98   | Ebino City, Miyazaki Pref.      | A-9a | 41284        | AB639523 | AB639694 |
| 99   | Yatsushiro City, Kumamoto Pref. | A-9a | 27562        | AB639524 | AB639691 |
| 100  | Amakusa City, Kumamoto Pref.    | A-9a | 30342        | AB639525 | AB639692 |
| 101  | Soo City, Kagoshima Pref.       | A-9a | 42191        | AB639526 | AB639693 |
| 102  | Izumi City, Kagoshima Pref.     | A-9a | 27564        | AB639527 | AB639694 |
| 103  | Kanoya City, Kagoshima Pref.    | A-9a | 27295, 43404 | AB639530 | AB639697 |
| 104  | Nobeoka City, Miyazaki Pref.    | A-9b | 27121        | AB639528 | AB639695 |
| 105  | Nishimera-son, Miyazaki Pref.   | A-9b | 26088        | AB639529 | AB639696 |
| 106  | Aya Town, Miyazaki Pref.        | A-9b | 42194        | AB639531 | AB639698 |
| 107  | Miyakonojo City, Miyazaki Pref. | A-9b | 30907        | AB639532 | AB639699 |
| 108  | Kimotsuki Town, Kagoshima Pref. | A-9b | 43397        | AB639533 | AB639700 |
| 109a | Kanoya City, Kagoshima Pref.    | A-9b | 43401        | AB639534 | AB639701 |
| 109b |                                 |      | 43403        | AB639535 | AB639702 |
| 110a | Kinko Town, Kagoshima Pref.     | A-9b | 27678        | AB639536 | AB639703 |
| 110b |                                 |      | 41250        | AB639537 | AB639704 |
| 111  | Goto City, Nagasaki Pref.       | A-9c | 31539        | AB639538 | AB639705 |
| 112a | Taga Town, Shiga Pref.          | B-2a | 43508        | AB639539 | AB639706 |
| 112b |                                 |      | 43509        | AB639540 | AB639707 |
| 113  | Konan City, Shiga Pref.         | B-2a | 18763        | AB639541 | AB639708 |
| 114a | Koka City, Shiga Pref.          | B-2a | 28466        | AB639542 | AB639709 |
| 115  | Kyotango City, Kyoto Pref.      | B-2a | 24566        | AB639544 | AB639729 |
| 116  | Maizuru City, Kyoto Pref.       | B-2a | TMP_T3345    | AB639545 | AB639711 |
| 117a | Kyoto City, Kyoto Pref.         | B-2a | 27168        | AB639546 | AB639712 |
| 117b |                                 |      | 41431        | AB639547 | AB639714 |
| 118  | Kameoka City, Kyoto Pref.       | B-2a | 41553        | AB639548 | AB639713 |
| 119  | Joyo City, Kyoto Pref.          | B-2a | 41554        | AB639549 | AB639714 |
| 120  | Komono Town, Mie Pref.          | B-2a | 26744        | AB639550 | AB639715 |
| 121  | Matsuzaka City, Mie Pref.       | B-2a | 41484        | AB639551 | AB639716 |
| 122  | Owase City, Mie Pref.           | B-2a | 26990        | AB639552 | AB639717 |
| 123a | Odai Town, Mie Pref.            | B-2a | 40190        | AB639553 | AB639718 |
| 124  | Izumi City, Osaka Pref.         | B-2a | TMP_T3425    | AB639556 | AB639721 |
| 125  | Soni Village, Nara Pref.        | B-2a | 24435        | AB639557 | AB639722 |

Table 2-1. Continued.

|                              |                                        |      |           |          |          |
|------------------------------|----------------------------------------|------|-----------|----------|----------|
| 126                          | Sakurai City, Nara Pref.               | B-2a | 18893     | AB639558 | AB639723 |
| 127                          | Kudoyama Town, Wakayama Pref.          | B-2a | 24546     | AB639559 | AB639724 |
| 128                          | Hongu Town, Wakayama Pref.             | B-2a | 26784     | AB639560 | AB639725 |
| 129                          | Shingu City, Wakayama Pref.            | B-2a | 24540     | AB639560 | AB639726 |
| 130                          | Gobo City, Wakayama Pref.              | B-2a | 41229     | AB639561 | AB639727 |
| 131                          | Kami Town, Hyogo Pref.                 | B-2a | 43603     | AB639562 | AB639728 |
| 132                          | Taka Town, Hyogo Pref.                 | B-2a | 10330     | AB639564 | AB639729 |
| 133                          | Sayo Town, Hyogo Pref.                 | B-2a | 41021     | AB639563 | AB639729 |
| 134                          | Kamigori Town, Hyogo Pref.             | B-2a | 41022     | AB639563 | AB639729 |
| 135                          | Mimasaka City, Okayama Pref.           | B-2a | 27659     | AB639564 | AB639730 |
| 136                          | Misasa Town, Tottori Pref.             | B-2b | 24574     | AB639565 | AB639731 |
| 137                          | Daisen Town, Tottori Pref.             | B-2b | 36824     | AB639566 | AB639732 |
| 138                          | Uttan City, Shimane Pref.              | B-2b | 18877     | AB639567 | AB639734 |
| 139a                         | Shobara City, Hiroshima Pref.          | B-2b | 36037     | AB639568 | AB639733 |
| 139b                         |                                        |      | 36040     | AB639569 | AB639734 |
| 140                          | Shobara City, Hiroshima Pref.          | B-2b | 24553     | AB639570 | AB639735 |
| 141                          | Hatsukaichi City, Hiroshima Pref.      | B-2b | UN        | AB639571 | AB639736 |
| 142                          | Higashihiroshima City, Hiroshima Pref. | B-2b | 30262     | AB639572 | AB639737 |
| 143                          | Higashihiroshima City, Hiroshima Pref. | B-2b | 30220     | AB639573 | AB639738 |
| 144                          | Hagi City, Yamaguchi Pref.             | B-2b | 42848     | AB639574 | AB639739 |
| 145                          | Shimonoseki City, Yamaguchi Pref.      | B-2b | 34516     | AB639575 | AB639740 |
| <i>R. t. yakushimensis</i>   |                                        |      |           |          |          |
| 146a                         | Yakushima Town, Kagoshima Pref.        | A-8  | 10182     | AB639578 | AB639741 |
| 146b                         |                                        |      | 43326     | AB639577 | AB639741 |
| <i>R. t. okiensis</i>        |                                        |      |           |          |          |
| 147a                         | Okinoshima Town, Shimane Pref.         | B-1  | 10818     | AB639576 | AB639742 |
| 147b                         |                                        |      | 22341     | AB639579 | AB639742 |
| 148                          | Nishinoshima Town, Shimane Pref.       | B-1  | 43647     | AB639580 | AB639742 |
| <i>R. sakuraii</i>           |                                        |      |           |          |          |
| 20b                          | Kanuma City, Tochigi Pref.             | A-2  | 43635     | AB639423 | AB639744 |
| 35b                          | Ibigawa Town, Gifu Pref.               | A-3  | 36297     | AB639437 | AB639620 |
| 44d                          | Nantan City, Kyoto Pref.               | A-3  | UN        | AB639454 | AB639631 |
| 44e                          |                                        |      | 41412     | AB639455 | AB639632 |
| 44f                          |                                        |      | 41413     | AB639456 | AB639632 |
| 60b                          | Akiruno City, Tokyo Pref.              | A-2  | 42450     | AB639583 | AB639744 |
| 114b                         | Koka City, Shiga Pref.                 | A-3  | TMP_T2666 | AB639543 | AB639710 |
| 123b                         | Odai Town, Mie Pref.                   | A-3  | 27647     | AB639554 | AB639719 |
| 123c                         |                                        |      | 40309     | AB639555 | AB639720 |
| 149                          | Naganohara Town, Gunma Pref.           | A-2  | 27937     | AB639581 | AB639744 |
| 150                          | Chichibu City, Saitama Pref.           | A-2  | 43736     | AB639582 | AB639743 |
| 151                          | Okutama Town, Tokyo Pref.              | A-2  | UN        | AB639583 | AB639744 |
| 152                          | Kiyokawa Village, Kanagawa Pref.       | A-2  | 14276     | AB639584 | AB639745 |
| 153                          | Matsumoto City, Nagano Pref.           | A-2  | 22887     | AB639585 | AB639746 |
| 154                          | Fujikawa Town, Yamanashi Pref.         | A-2  | 43481     | AB639586 | AB639747 |
| 155                          | Itoigawa City, Niigata Pref.           | A-3  | 31300     | AB639587 | AB639748 |
| 156                          | Hamamatsu City, Shizuoka Pref.         | A-3  | UN        | AB639588 | AB639749 |
| 157                          | Nakatsugawa City, Gifu Pref.           | A-3  | 18201     | AB639589 | AB639749 |
| 158                          | Iwakuni City, Yamaguchi Pref.          | A-3  | 43893     | AB639590 | AB639750 |
| <i>R. tsushimensis</i>       |                                        |      |           |          |          |
|                              | Tsushima City, Nagasaki Pref.          |      | 11606     | AB639592 | AB639752 |
| <i>Lithobates sylvaticus</i> |                                        |      |           |          |          |
|                              | Quebec, Canada                         |      | UN        | AB639591 | AB639751 |

**Table 2-2.** Primers used to amplify mtDNA in this study.

| Target     | Name        | Sequence                     | Reference                      |
|------------|-------------|------------------------------|--------------------------------|
| <i>16S</i> | L1507       | TACACACCGCCCGTCACCCTCTT      | Shimada <i>et al.</i> (2011)   |
|            | H1923       | AAGTAGCTCGCTTAGTTTCGG        | Shimada <i>et al.</i> (2011)   |
|            | L1879       | CGTACCTTTTGCATCATGGTC        | Shimada <i>et al.</i> (2011)   |
|            | H2315       | TTCTTGTTACTAGTTCTAGCAT       | Shimada <i>et al.</i> (2011)   |
|            | L2188       | AAAGTGGGCCTAAAAGCAGCCA       | Matsui <i>et al.</i> (2006)    |
|            | Wilkinson_6 | CCCTCGTGATGCCGTTGATAC        | Wilkinson <i>et al.</i> (2002) |
|            | 16L1        | CTGACCGTGCAAAGGTAGCGTAATCACT | Hedges (1994)                  |
|            | 16H1        | CTCCGGTCTGAACTCAGATCACGTAGG  | Hedges (1994)                  |
|            | <i>ND1</i>  | L3032                        | CGACCTCGATGTTGGATCAGG          |
| ND1_Htago  |             | GRGCRATTTTGGAGTTTGARGCTCA    | this study                     |
| ND1_Ltago  |             | GACCTAAACCTCAGYATYCTATTTAT   | this study                     |
| tMet_H     |             | AGGAAGTACAAAGGGTTTTGATC      | Shimada <i>et al.</i> (2011)   |

**Table 2-3.** Alignment statistics for total 16S rRNA and ND1. The number of base pairs (bp), variable sites (vs), number of parsimony informative sites (pi), the transition-transversion ratio (ti/tv) are given for ingroups only.

|            | bp   | vs  | pi  | ti/tv |
|------------|------|-----|-----|-------|
| <i>16S</i> | 1554 | 310 | 206 | 6.65  |
| <i>ND1</i> | 967  | 314 | 250 | 9.38  |
| Combined   | 2521 | 624 | 456 | 8.04  |

**Table 2-4.** Mean uncorrected p-distances (%) among genetic groups of three subspecies of *R. tagoi* and *R. sakuraii* for 16S rRNA (above diagonal) and ND1 (below diagonal). Darkly shaded areas indicate distances among groups with sympatric distribution and lightly shaded areas indicate distances among groups with parapatric distribution.

|                               | 1   | 2   | 3   | 4   | 5   | 6   | 7   | 8   | 9   | 10  | 11  | 12  | 13  | 14  | 15  | 16  |
|-------------------------------|-----|-----|-----|-----|-----|-----|-----|-----|-----|-----|-----|-----|-----|-----|-----|-----|
| 1. A-1a                       | -   | 1.3 | 1.6 | 1.9 | 1.6 | 1.4 | 1.5 | 1.9 | 1.9 | 1.7 | 1.8 | 2.0 | 1.7 | 3.0 | 3.3 | 3.0 |
| 2. A-1b                       | 4.1 | -   | 1.8 | 2.1 | 1.7 | 1.6 | 1.6 | 1.9 | 2.1 | 1.6 | 2.0 | 2.3 | 1.8 | 2.8 | 3.2 | 2.9 |
| 3. A-2 ( <i>R. t. tagoi</i> ) | 3.9 | 4.3 | -   | 1.1 | 1.7 | 1.3 | 1.6 | 1.9 | 1.9 | 1.7 | 1.9 | 2.2 | 1.8 | 2.9 | 3.1 | 2.8 |
| 4. A-2 ( <i>R. sakuraii</i> ) | 4.2 | 4.2 | 2.1 | -   | 1.9 | 1.4 | 1.8 | 2.0 | 2.1 | 1.9 | 2.1 | 2.4 | 2.1 | 3.0 | 3.1 | 2.8 |
| 5. A-3                        | 4.7 | 5.0 | 3.7 | 3.6 | -   | 1.4 | 1.5 | 1.9 | 2.1 | 1.8 | 1.9 | 2.2 | 1.8 | 2.7 | 3.0 | 2.6 |
| 6. A-4                        | 3.9 | 4.3 | 3.0 | 3.3 | 4.1 | -   | 1.3 | 1.7 | 1.8 | 1.5 | 1.7 | 2.0 | 1.6 | 2.7 | 2.8 | 2.6 |
| 7. A-5                        | 4.4 | 4.9 | 3.5 | 3.8 | 4.4 | 3.0 | -   | 1.5 | 2.1 | 1.7 | 2.0 | 2.3 | 1.9 | 2.9 | 3.1 | 2.8 |
| 8. A-6                        | 5.0 | 4.7 | 4.3 | 4.3 | 5.4 | 3.4 | 4.1 | -   | 2.3 | 2.0 | 2.3 | 2.5 | 2.1 | 2.9 | 3.3 | 2.8 |
| 9. A-7                        | 4.7 | 5.2 | 3.8 | 4.4 | 5.1 | 4.1 | 4.7 | 5.3 | -   | 1.8 | 2.0 | 2.4 | 1.9 | 3.0 | 3.1 | 2.7 |
| 10. A-8                       | 4.0 | 4.4 | 3.1 | 3.4 | 3.9 | 2.8 | 3.6 | 4.0 | 3.1 | -   | 1.8 | 2.1 | 1.6 | 2.7 | 2.8 | 2.7 |
| 11. A-9a                      | 5.2 | 5.3 | 4.2 | 4.4 | 5.4 | 4.4 | 4.8 | 5.4 | 4.4 | 3.4 | -   | 1.7 | 1.3 | 3.2 | 3.2 | 2.9 |
| 12. A-9b                      | 4.7 | 5.1 | 3.8 | 4.1 | 4.8 | 3.7 | 4.2 | 4.9 | 4.1 | 2.8 | 3.0 | -   | 1.4 | 3.3 | 3.5 | 3.1 |
| 13. A-9c                      | 5.0 | 5.2 | 4.1 | 3.9 | 5.0 | 4.0 | 4.7 | 5.3 | 4.1 | 3.3 | 3.2 | 2.9 | -   | 2.9 | 3.1 | 2.8 |
| 14. B-1                       | 6.1 | 6.4 | 5.6 | 6.0 | 6.5 | 5.3 | 5.9 | 6.1 | 5.9 | 5.4 | 6.3 | 6.2 | 6.4 | -   | 2.0 | 1.8 |
| 15. B-2a                      | 6.9 | 6.7 | 5.9 | 6.3 | 6.5 | 5.9 | 6.3 | 6.7 | 6.3 | 5.8 | 6.7 | 6.6 | 6.6 | 4.1 | -   | 1.3 |
| 16. B-2b                      | 7.0 | 6.9 | 5.7 | 6.1 | 7.0 | 5.9 | 6.5 | 6.6 | 6.3 | 6.0 | 6.4 | 6.4 | 6.4 | 4.4 | 2.9 | -   |





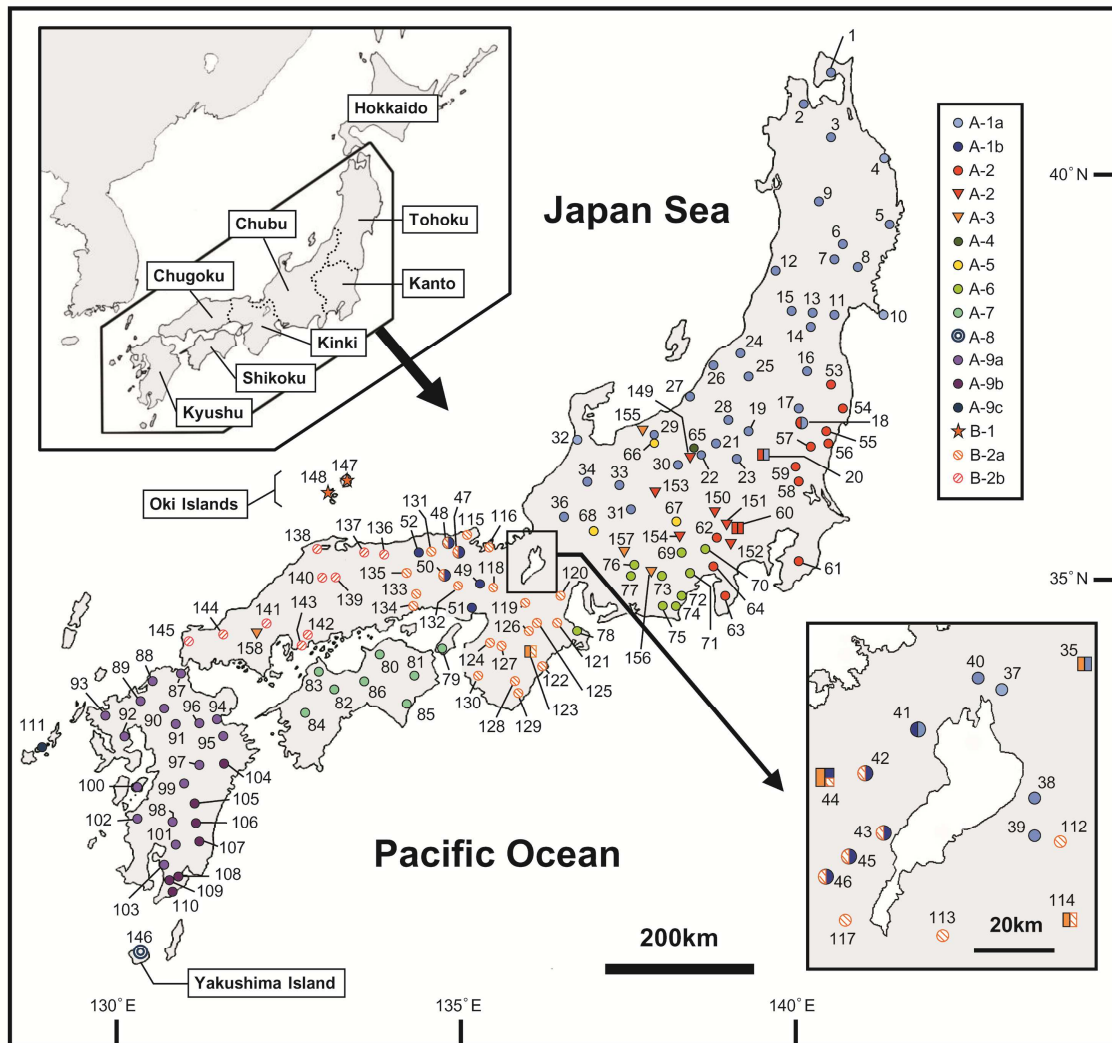

Figure 2-1



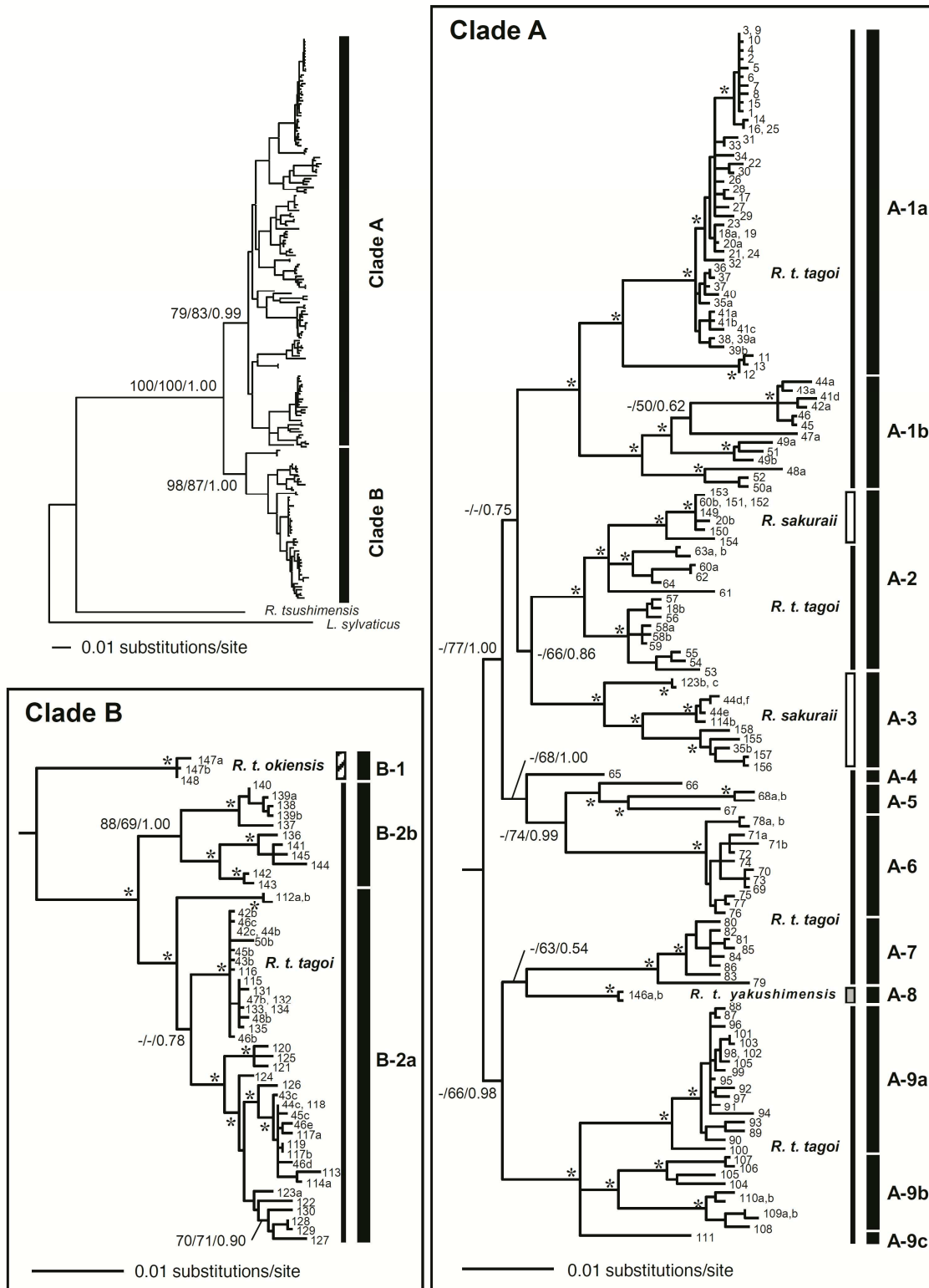
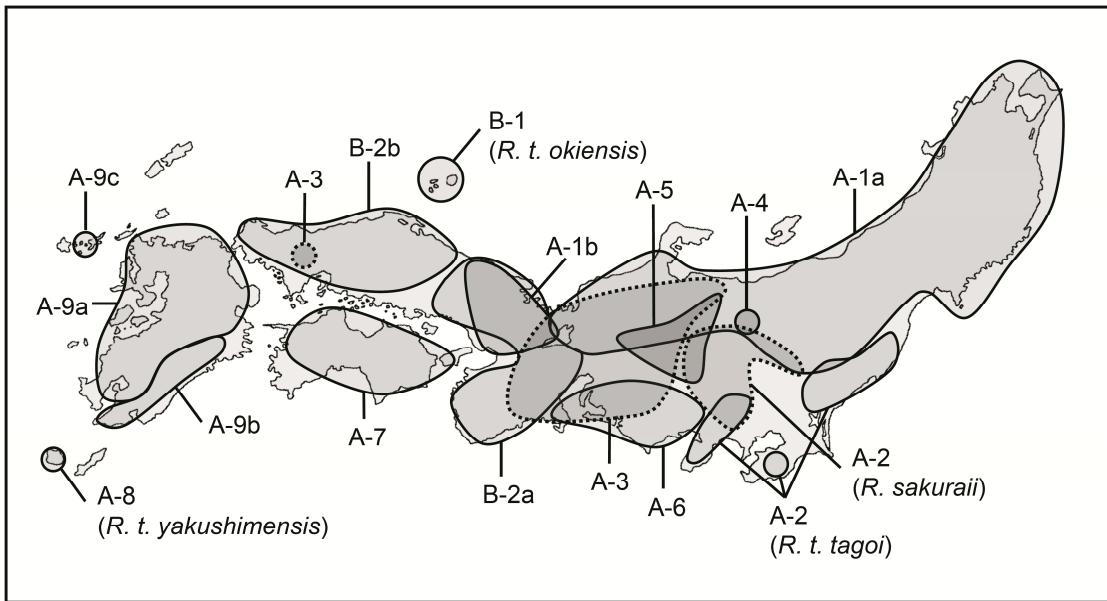

Figure 2-2





**Figure 2-3**



## CHAPTER 3

### **Discordance between Mitochondrial DNA Genealogy and Nuclear DNA Genetic Structure in the Two Morphotypes of *Rana tagoi tagoi* in the Kinki Region, Japan**

#### **3-1 INTRODUCTION**

In Chapter 2, I showed that *R. tagoi* and its close relative *R. sakuraii* are highly divergent genetically with complex evolutionary histories, and at least *R. tagoi* is thought to include many cryptic taxa. Within the resultant mitochondrial genealogy, one of the two morphotypes of *R. t. tagoi* from the Kinki region (Sugahara 1990), “large type”, is split into two major clades (A and B). Moreover, one of the two “large” lineages (Group A-1a) is more closely related to the “small type” lineage (Group A-1b) in Clade A, while the other (Group B-2a) is nested in Clade B.

Mitochondrial (mt) DNA used in Chapter 2 is very widely employed in phylogenetic studies, given its high variability and many traits suitable for experiments and analyses (Avice 2000). However, the results of some recent studies have revealed that phylogenies derived from mtDNA do not always agree with those obtained from other sources like morphology (e.g., Liu *et al.* 2010; Hamidy *et al.* 2011), as is the case in two morphotypes of *R. t. tagoi* described above. Thus, it is desirable to confirm the validity of phylogenetic relationships from mtDNA using other genetic markers.

In this Chapter, I conducted phylogenetic and population genetic analyses using nuclear (n) DNA sequences in order to assess detailed genetic and taxonomic relationships of the two morphotypes with three mt-lineages of *R. t. tagoi* in the Kinki region. By doing this, I tried to infer the states of reproductive isolations among each of the mitochondrial lineages in question.

#### **3-2 MATERIALS AND METHODS**

For samples from the Kinki region, I distinguished the “large” and “small” types based

on body size and other diagnostic characters as described by Sugahara & Matsui (1994). In fact, some samples with mtDNA and morphological traits of the “large type” showed body sizes intermediate between the two types, but these were treated as the “large type”.

I first ascertained the mtDNA phylogeny obtained in Chapter 2 using 186 samples of *R. t. tagoi* from 41 localities in the Kinki region and nine samples from the type locality in the Chubu region (Fig. 3-1 and Table. 3-1). The data include 23 mtDNA sequences from GenBank (accession numbers AB639617, AB639621-AB639630, AB639633-AB639635, AB639706-AB639709, and AB639711-AB639715). I used *R. sauteri* and *R. tsushimensis* (AB685767 and AB639752) as outgroup taxa.

Based on the results of mtDNA analysis, I selected 126 samples from six locality groups of the Kinki region (see result) and nine topotypic samples, and conducted genetic analyses using nDNA sequences. These localities were chosen to represent sites where (1) a single mitochondrial genetic group occurs, (2) two or three groups occur sympatrically, and/or (3) each mitochondrial group occurs parapatrically, exhibiting boundary areas. When samples belonging to different mitochondrial groups co-occurred in a locality, I treated them as different units in the analyses.

Following the experimental conditions and techniques described in Chapter 2, I first analyzed approximately 600 bp of *ND1* (NADH dehydrogenase subunit 1) fragments of mtDNA. Then phylogenetic trees based on maximum likelihood (ML) and Bayesian inference (BI) were constructed by using TREEFINDER ver. Mar. 2011 (Jobb 2011) and MrBayes ver. 3.2.0 (Ronquist & Huelsenbeck 2003), respectively. Methods for construction of trees also follow the previous chapter. I then amplified partial sequences of three nuclear genes (*NCX1* [sodium-calcium exchanger 1], *POMC* [pro-opiomelanocortin], and *RAG1* [recombination activating gene 1]) by PCR using primer sets listed in Table 3-2. The experimental conditions and techniques were essentially same as those in mtDNA analysis. I used PHASE ver. 2.1 (Stephens *et al.* 2001) to separate and determine haplotypes of heterozygotic individuals. I considered haplotypes supported by BPP 0.95 or greater as significant; others were treated as missing data.

To estimate relationships between nDNA haplotypes, statistical parsimony networks for each gene were constructed by using TCS version 1.21 (Clement *et al.* 2000). I also performed



population genetic analyses based on nDNA haplotypes. For each population, genetic variability was assessed by calculating the mean observed ( $H_o$ ) and expected ( $H_e$ ) heterozygosities, and all genes were checked with chi-square goodness-of-fit tests to determine whether or not they were deviated from Hardy-Weinberg (HW) equilibrium. All these analyses were conducted by using GENALEX 6.41 (Peakall & Smouse 2006). To estimate population genetic structure, I used STRUCTURE ver. 2.3.3 (Pritchard *et al.* 2000) with admixture model. The most likely number of clusters ( $K$ ) was estimated according to the delta  $K$  value (Evanno *et al.* 2005).

### **3-3 RESULTS**

#### **3-3-1 Phylogenetic relationships based on mtDNA sequences**

I obtained 564 bp of the mitochondrial *ND1* gene for all samples, and after combining identical sequences, total 51 sequences were used in the subsequent analysis. Within the ingroup sequences, 83 variable sites ( $vs$ ) and 55 parsimony-informative sites ( $pi$ ) were included. Newly obtained sequences were deposited in GenBank (AB779781–AB779812). The best substitution models estimated by Kakusan 4 (Tanabe 2011) for ML and BI were J1 model (Jobb 2011) with a gamma shape parameter ( $G$ ) and Hasegawa-Kishino-Yano-1985 (HKY85) +  $G$ , respectively.

Phylogenetic analyses based on ML and BI yielded essentially identical topologies (-lnL = 2029.55 and 2290.28, respectively), and only BI tree is shown in Fig. 3-2. Just same as Chapter 2, the ingroup was divided into three clades corresponding to Groups A-1a (ML-BS = 97% and BPP = 1.00, respectively), A-1b (96% and 1.00), and B-1a (91% and 1.00). Groups A-1a and A-1b formed a clade (99% and 1.00) with closer genetic similarity in between (mean p-distance = 3.7%) than to B-2a (p-distance between A-1a = 6.7% and between A-1b = 6.5%).

Geographically, Groups A-1a and B-2a of the “large type” occurred parapatrically, with the former distributed in northeastern part and the latter in southwestern part of the sampling area. In contrast, distribution of the “small type” Group A-1b samples largely overlapped with them in the western side of Lake Biwa (Fig. 3-1).

### 3-3-2 Genetic variations in nuclear genes

Samples selected for nDNA analyses were 126 from six locality groups, consisting of localities (Locs.) 7, 13-16, 27, 31, 35, and 38–40 (Fig. 3-1), and nine topotypic ones from Loc. 1. Among them, a single mitochondrial genetic group was recognized in Locs. 1 (A-1a), 7 (A-1a), 31 (B-2a), and 35 (B-2a), and two groups occurred sympatrically in Loc. 27 (A-1b and B-2a). The boundary areas of multiple groups were located in 13-16 (A-1a and B-2a, with sympatric samples of A-1b) and 38-40 (A-1a and B-2a). For subsequent analyses, I differentiated these mitochondrial lineages in a given locality group (Table 3-3).

After a haplotype reconstruction using PHASE ver. 2.1, a total of 13 haplotypes (“a” to “m” in Fig. 3-3A) were obtained in *NCXI* (535bp;  $vs = 14$ ,  $pi = 8$ ), 23 haplotypes (“a” to “w” in Fig. 3-3B) in *POMC* (552bp;  $vs = 24$ ,  $pi = 12$ ), and 13 haplotypes (“a” to “m” in Fig. 3-3C) in *RAG1* (454bp;  $vs = 14$ ,  $pi = 11$ ). Each haplotype was deposited in GenBank (AB779768–AB779780, AB779813–AB779848). In some samples (two in *NCXI*, one in *POMC*, and 11 in *RAG1*), I could not reconstruct their haplotypes with significant support ( $< 0.95$ ). Thus these samples were omitted in the haplotype network analyses, although I used them in the structure analysis by applying missing data value.

Haplotype networks and frequencies of each gene are shown in Fig. 3-3 and Table 3-3, respectively. Two haplotype groups were recognized in the network of *NCXI* (Fig. 3-3A): one of them mainly consisted of the haplotypes specific to samples belonging to Group A-1a and B-2a (e.g., haplotypes “a” and “b”), and another one mainly consisted of haplotypes specific to Group A-1b (e.g., “l” and “m”). The haplotype network of *POMC* (Fig. 3-3B) also included several haplotype groups, which exhibited following tendencies: haplotypes specific to or frequently observed in Group A-1b samples (e.g., haplotypes “v” and “w”) tended to form a group; haplotypes frequently observed in A-1a and B-2a samples from Locs. 7, 13-16, 27, and 31 (e.g., “a” and “c”) tended to form a group; topotypic samples from Loc. 1 possessed some unique haplotypes (“q” and “r”), although they largely shared haplotypes (“a” and “c”) with A-1a and B-2a samples from the other localities. The haplotype network of *RAG1* (Fig. 3-3C) included three distinct haplotype groups that did not clearly match the groupings by either mitochondrial genealogy or geographic distribution, but weakly showed the following tendencies: haplotypes frequently observed in samples of Group B-2a from Locs. 27 and 31,

and A-1b (e.g., haplotypes “b” and “m”) tended to form a group, which also included several haplotypes from other mitochondrial groups or localities; haplotypes specific to samples of A-1a and B-2a from Locs. 35 and 38-40 (“g” and “h”) formed a group.

Statistics on the genetic variability of mitochondrial groups from each locality are shown in Table 3-3. No significant deviation from HW expectations was observed in each gene/locality. The structure analysis was performed for up to  $K = 10$ , and resultant barplots for  $K = 2$  to 4 are shown in Fig. 3-4. The likelihood values reached a plateau after  $K = 2$ , and the estimated delta  $K$  value was highest at  $K = 2$  (data not shown). At  $K = 2$ , two clusters, one including mitochondrial Groups A-1a and B-2a and another corresponding to Group A-1b were recognized. At  $K = 3$ , the cluster of A-1a + B-2a at  $K = 2$  was further divided into two clusters, but the division did not support the separation of two mitochondrial groups. Based on the test of delta  $K$  and clustering patterns of each bar plot, the most plausible number of clusters was considered to be two, by which the “large type” (mitochondrial Groups A-1a and B-2a) and the “small type” (mitochondrial Group A-1b) were split.

### **3-4 DISCUSSION**

#### **3-4-1 Discordance of estimated relationships among genetic markers**

As shown in Chapter 2, the results of phylogenetic analyses based on mtDNA did not support morphological delimitation of *R. t. tagoi* from the Kinki region. Obtained genealogy showed that the *R. t. tagoi* “large type” was not monophyletic, and was split into two highly differentiated lineages. In contrast, the results of nDNA analyses did not support such a mitochondrial relationship, but were congruent with morphological delimitation.

Discordance of results between mt- and n-DNA analyses could be explained by mitochondrial incomplete lineage sorting (ILS) or gene introgression derived from past hybridization among ancestral lineages (Avice 2000; Ballard & Whitlock 2004). Because lineage sorting normally progresses rapidly in mtDNA, ILS of mtDNA is rare compared to that of nDNA (Ballard & Whitlock, 2004). However, lineages of *R. tagoi* are thought to have diverged recently from their relatively small genetic divergences (see the previous and the next chapters), and therefore the possibility of mtDNA ILS, even at the species level, is not completely rejected (e.g., as a product of budding speciation: Funk & Omland 2003). In this

scenario, the ancestor of the *R. t. tagoi* “small type” (A-1b) originated as an internal lineage of the “large type” (A-1a and B-2a). The ancestral populations of A-1b subsequently underwent morphological and ecological differentiation toward the smaller body size, while ancestral A-1a and B-2a populations retained their larger body size.

On the other hand, past mitochondrial introgression among ancestors of each lineage can also explain the discordance of mtDNA and nDNA properties. Based on this hypothesis, hybridization between the ancestral populations of A-1b (or other Clade A lineages) and B-2a had occurred in past, resulting in mtDNA introgression from the former to the latter. After the introgression event, mtDNA in the ancestral populations of B-2a, A-1b, and the introgressed populations of B-2a (ancestral A-1a) independently experienced mutations and resulted in the formation of present relationships.

Mitochondrial ILS and past gene introgression are often difficult to distinguish (Funk & Omland 2003; Ballard & Whitlock 2004). In the case of present study, if ILS caused the discordance, the small type (A-1b) should be genetically close to one of the “large type” lineages (A-1a) not only in mtDNA, but also in nDNA. However, present results actually did not support close relationship of A-1a and A-1b in nDNA, thus not favoring ILS. Nonetheless, however, the ILS scenario may be supported by male-biased gene flow. In such a case, the original nuclear haplotypes and genetic structure of A-1a would have been similar to those of A-1b, but were completely overwritten via male-biased gene flow with B-2a. However, nDNA is fundamentally less likely to be introgressive than mtDNA, and no behavioral data for male-biased dispersal in this species are available at present. Compared with the ILS hypothesis, the past mtDNA introgression hypothesis is less problematic and is considered more plausible.

In addition to discordance of mt- and n-DNA, each nuclear gene also showed more or less discordant patterns on their haplotype networks. Among three nuclear genes, only *NCXI* showed obvious relationships between the haplotype network and the morphotype. This result suggests that the ILS of the remaining two genes (*POMC* and *RAG1*) may have caused discordance among nuclear genes. These results seem to indicate that phylogenetic analyses using direct sequences of nuclear genes may not be efficient in the study of *R. tagoi*, and that population genetic analyses based on frequency data of nuclear genotypes could be more

effective (Avice 2000).

### **3-4-2 Taxonomic status of two morphotypes of *Rana t. tagoi***

Sympatric occurrence of two types of *Rana t. tagoi* was first reported from Kyoto Prefecture in the Kinki region by Sugahara (1990). Later, Sugahara & Matsui (1992, 1993, 1994, 1995, 1996, and 1997) performed morphological, acoustic, and ecological comparisons, and suggested that these two types were not conspecific, being reproductively isolated from each other. Subsequent genetic survey using mtDNA (Tanaka *et al.* 1994) clarified remarkably large genetic divergences between the large (corresponding to B-2a in this paper) and the small (A-1b) types from Kyoto. Furthermore, as shown in Chapter 2, the “large type” was further divided into two genetic lineages (A-1a and B-2a), and one of them (A-1a) was phylogenetically close to the “small type” (A-1b). Present result of mtDNA analysis supported those in the previous chapter.

In contrast, analyses based on nDNA suggested a closer relationship of A-1a to B-2a than to A-1b. Present structure analysis indicated unlimited gene flow between A-1a and B-2a, and the existence of genetic isolation of A-1b from sympatric A-1a or B-2a was also suggested. These results are congruent with previous results of morphological and ecological studies (Sugahara & Matsui 1992, 1993, 1994, 1995, 1996, 1997), which indicated that the *R. t. tagoi* “large type” (A-1a and B-2a) and the “small type” (A-1b) from the Kinki region are specifically distinct.

In the nDNA analyses, the “large type” was genetically also close to topotypes of *R. t. tagoi* that have body size intermediate between the “large” and “small” types. These facts suggest that the “large type” is in fact conspecific with the topotypes, and should be treated as true *R. t. tagoi*, while the “small type” is a distinct but unnamed species. The reason for the presence of size variation within true *R. t. tagoi* (the “large” and the “medium” types) is unknown, but may be the result of character displacement derived from co-occurrence of the “large” and “small” lineages and their interspecific interference (Sugahara & Matsui 1996), unlike singly occurring “medium type”.

## FIGURE LEGENDS

**Fig. 3-1.** Map of the Kinki region, Japan, showing sampling localities of *Rana t. tagoi*. Open, closed, and shaded circles indicate localities with mitochondrial genetic groups B-2a, A-1b, and A-2a, respectively, and the star shows the type locality in the Chubu region. Ranges encircled by dashed lines indicate localities used in nDNA analyses. Figures indicate localities shown in Table 3-1.

**Fig. 3-2.** Bayesian tree of mitochondrial ND1 gene for *Rana t. tagoi* and outgroup taxa. Nodal values indicate bootstrap supports for ML (above) and Bayesian posterior probability (below). For locality information, see Table 3-1 and Fig. 3-1.

**Fig. 3-3.** Statistical parsimony networks of (A) *NCX1*, (B) *POMC*, and (C) *RAG1* haplotypes of *Rana. t. tagoi* from northeastern Kinki region and type locality. Filled circles indicate missing haplotypes. The size of each open circle is proportional to the haplotype frequency.

**Fig. 3-4.** Assigned genetic clusters of 135 individuals of *R. t. tagoi* from six locality groups in the Kinki and the type locality by structure analysis ( $k = 2-4$ ). For locality numbers, see Fig. 3-1 and Table 3-1.

**Table 3-1.** Numbers and names of sampling localities, assigned mitochondrial genetic groups, and sample sizes of *Rana t. tagoi* examined.

| No.                      | Locality                             | MtDNA group | n  |
|--------------------------|--------------------------------------|-------------|----|
| <i>Rana t. tagoi</i>     |                                      |             |    |
| 1                        | Takayama City, Gifu Pref.            | A-1a        | 9  |
| 2                        | Ibigawa Town, Gifu Pref.             | A-1a        | 1  |
| 3                        | Nagahama City, Shiga Pref.           | A-1a        | 1  |
| 4                        | Maibara City, Shiga Pref.            | A-1a        | 2  |
| 5                        | Nagahama City, Shiga Pref.           | A-1a        | 2  |
| 6                        | Nagahama City, Shiga Pref.           | A-1a        | 2  |
| 7                        | Nagahama City, Shiga Pref.           | A-1a        | 11 |
| 8                        | Nagahama City, Shiga Pref.           | A-1a        | 1  |
| 9                        | Mihama Town, Fukui Pref.             | A-1a        | 1  |
| 10                       | Mihama Town, Fukui Pref.             | A-1a        | 1  |
| 11                       | Mihama Town, Fukui Pref.             | A-1a        | 1  |
| 12                       | Mihama Town, Fukui Pref.             | A-1a        | 1  |
|                          |                                      | A-1b        | 1  |
| 13                       | Takashima City, Shiga Pref.          | A-1a        | 5  |
|                          |                                      | A-1b        | 9  |
| 14                       | Takashima City, Shiga Pref.          | A-1b        | 1  |
| 15                       | Takashima City, Shiga Pref.          | A-1a        | 15 |
|                          |                                      | A-1b        | 2  |
|                          |                                      | B-2a        | 7  |
| 16                       | Takashima City, Shiga Pref.          | A-1b        | 2  |
|                          |                                      | B-2a        | 3  |
| 17                       | Takashima City, Shiga Pref.          | A-1b        | 1  |
|                          |                                      | B-2a        | 1  |
| 18                       | Takashima City, Shiga Pref.          | B-2a        | 7  |
| 19                       | Takashima City, Shiga Pref.          | A-1b        | 2  |
|                          |                                      | B-2a        | 2  |
| 20                       | Takashima City, Shiga Pref.          | B-2a        | 2  |
| 21                       | Otsu City, Shiga Pref.               | A-1b        | 4  |
|                          |                                      | B-2a        | 6  |
| 22                       | Otsu City, Shiga Pref.               | B-2a        | 2  |
| 23                       | Oi Town, Fukui Pref.                 | A-1b        | 1  |
| 24                       | Nantan City, Kyoto Pref.             | A-1b        | 2  |
|                          |                                      | B-2a        | 6  |
| 25                       | Kyoto City, Kyoto Pref.              | A-1b        | 1  |
|                          |                                      | B-2a        | 1  |
| 26                       | Kyoto City, Kyoto Pref.              | A-1b        | 1  |
|                          |                                      | B-2a        | 3  |
| 27                       | Kyoto City, Kyoto Pref.              | A-1b        | 16 |
|                          |                                      | B-2a        | 14 |
| 28                       | Otsu City, Shiga Pref.               | B-2a        | 3  |
| 29                       | Kyoto City, Kyoto Pref.              | B-2a        | 2  |
| 30                       | Kyoto City, Kyoto Pref.              | B-2a        | 1  |
| 31                       | Kyoto City, Kyoto Pref.              | B-2a        | 12 |
| 32                       | Kyoto City, Kyoto Pref.              | B-2a        | 1  |
| 33                       | Otsu City, Shiga Pref.               | B-2a        | 1  |
| 34                       | Konan City, Shiga Pref.              | B-2a        | 1  |
| 35                       | Koka City, Shiga Pref.               | B-2a        | 9  |
| 36                       | Higashiomi City, Shiga Pref.         | B-2a        | 1  |
| 37                       | Komono Town, Mie Pref.               | B-2a        | 1  |
| 38                       | Taga Town, Shiga Pref.               | B-2a        | 5  |
| 39                       | Taga Town, Shiga Pref.               | A-1a        | 1  |
| 40                       | Taga Town, Shiga Pref.               | A-1a        | 5  |
| 41                       | Maibara City, Shiga Pref.            | A-1a        | 2  |
| <i>Rana tsushimensis</i> |                                      |             |    |
|                          | Tsushima City, Nagasaki Pref., Japan |             | 1  |
| <i>Rana sauteri</i>      |                                      |             |    |
|                          | Alishan, Chiayi Country, Taiwan      |             | 1  |

**Table 3-2.** Primers used to amplify nuclear genes in this study.

| Target      | Name           | Sequence                      | Reference                    |
|-------------|----------------|-------------------------------|------------------------------|
| <i>NCX1</i> | NCX1F          | ACAACAGTRAGRATATGGAA          | Shimada <i>et al.</i> (2011) |
|             | NCX1R1         | GCCATATCTCTCCTCGCTTCTTC       | This study                   |
| <i>POMC</i> | POMC1          | GAATGTATYAAAGMMTGCAAGATGGWCCT | Wiens <i>et al.</i> (2005)   |
|             | POMC7          | TGGCATTTTTGAAAAGAGTCAT        | Smith <i>et al.</i> (2005)   |
| <i>RAG1</i> | Rag-1 Meristo1 | CAGTTCCTGAGAAAGCAGTACG        | Shimada <i>et al.</i> (2008) |
|             | Rag-1 Meristo2 | GGCTTTGCTGAAACTCCTTTC         | Shimada <i>et al.</i> (2008) |



**Table 3-3.** Haplotype frequencies and genetic variabilities at three nuclear genes (*NCX1*, *POMC*, and *RAG1*) among localities and mitochondrial genetic groups of *Rana t. tagoi*. For locality numbers, refer to Fig. 1 and Table 1.

| Loc.        | 1         | 7      | 13-16  |        |        | 27     |        | 31     | 35     | 38-40  |        |       |
|-------------|-----------|--------|--------|--------|--------|--------|--------|--------|--------|--------|--------|-------|
| MtDNA       | A-1a      | A-1a   | A-1a   | A-1b   | B-2a   | A-1b   | B-2a   | B-2a   | B-2a   | A-1a   | B-2a   |       |
| n           | 9         | 11     | 20     | 14     | 10     | 16     | 14     | 12     | 9      | 6      | 5      |       |
| <i>NCX1</i> | a0.722    | a0.455 | a0.342 | h0.036 | a0.300 | b0.031 | a0.731 | a1.000 | a1.000 | a0.583 | a0.900 |       |
|             | c0.111    | b0.091 | b0.526 | j0.036 | b0.650 | h0.031 | b0.269 |        |        | g0.250 | h0.100 |       |
|             | f0.056    | c0.227 | c0.079 | k0.250 | c0.050 | i0.031 |        |        |        | h0.167 |        |       |
|             | m0.111    | f0.091 | d0.026 | l0.071 |        | l0.281 |        |        |        |        |        |       |
|             |           | h0.136 | e0.026 | m0.607 |        | m0.625 |        |        |        |        |        |       |
| <i>Ho</i>   | 0.556     | 0.727  | 0.632  | 0.429  | 0.300  | 0.467  | 0.538  | -      | -      | 0.667  | 0.200  |       |
| <i>He</i>   | 0.451     | 0.707  | 0.598  | 0.561  | 0.485  | 0.524  | 0.393  | -      | -      | 0.569  | 0.180  |       |
| <i>POMC</i> | a0.056    | a0.250 | a0.700 | a0.071 | a0.591 | c0.063 | a0.821 | a0.375 | a0.300 | a0.083 | a0.100 |       |
|             | c0.611    | c0.250 | b0.075 | t0.071 | b0.227 | s0.094 | c0.179 | c0.208 | j0.350 | j0.333 | j0.400 |       |
|             | q0.278    | f0.150 | c0.100 | u0.071 | c0.091 | y0.156 |        | o0.083 | m0.200 | l0.333 | k0.200 |       |
|             | r0.065    | g0.100 | d0.075 | v0.214 | e0.045 | v0.438 |        | p0.333 | o0.100 | m0.167 | l0.100 |       |
|             |           | h0.100 | e0.050 | w0.571 | v0.045 | w0.250 |        |        | v0.050 | n0.083 | m0.200 |       |
|             |           | i0.050 |        |        |        |        |        |        |        |        |        |       |
|             |           | j0.050 |        |        |        |        |        |        |        |        |        |       |
|             |           | v0.050 |        |        |        |        |        |        |        |        |        |       |
|             | <i>Ho</i> | 0.667  | 0.900  | 0.500  | 0.571  | 0.700  | 0.867  | 0.214  | 0.750  | 0.667  | 0.833  | 0.600 |
|             | <i>He</i> | 0.543  | 0.825  | 0.486  | 0.612  | 0.570  | 0.700  | 0.293  | 0.698  | 0.716  | 0.736  | 0.740 |
| <i>RAG1</i> | a0.214    | a0.250 | a0.575 | a0.167 | a0.650 | a0.344 | a0.179 | a0.045 | b0.118 | a0.250 | b0.125 |       |
|             | b0.429    | b0.250 | b0.150 | b0.208 | b0.100 | b0.063 | b0.643 | b0.409 | c0.294 | g0.500 | c0.125 |       |
|             | f0.286    | d0.063 | c0.050 | j0.042 | c0.050 | j0.063 | m0.179 | c0.182 | d0.176 | h0.167 | g0.375 |       |
|             | m0.071    | f0.250 | d0.100 | l0.125 | f0.100 | k0.031 |        | i0.045 | g0.176 | m0.083 | h0.375 |       |
|             |           | j0.063 | e0.025 | m0.458 | i0.050 | l0.156 |        | m0.318 | h0.118 |        |        |       |
|             |           | m0.125 | j0.050 |        | m0.050 | m0.344 |        |        | m0.118 |        |        |       |
|             |           |        | m0.050 |        |        |        |        |        |        |        |        |       |
|             | <i>Ho</i> | 0.571  | 0.750  | 0.684  | 0.500  | 0.600  | 0.800  | 0.500  | 0.727  | 0.875  | 0.833  | 0.500 |
|             | <i>He</i> | 0.684  | 0.789  | 0.597  | 0.701  | 0.550  | 0.720  | 0.523  | 0.694  | 0.820  | 0.653  | 0.688 |



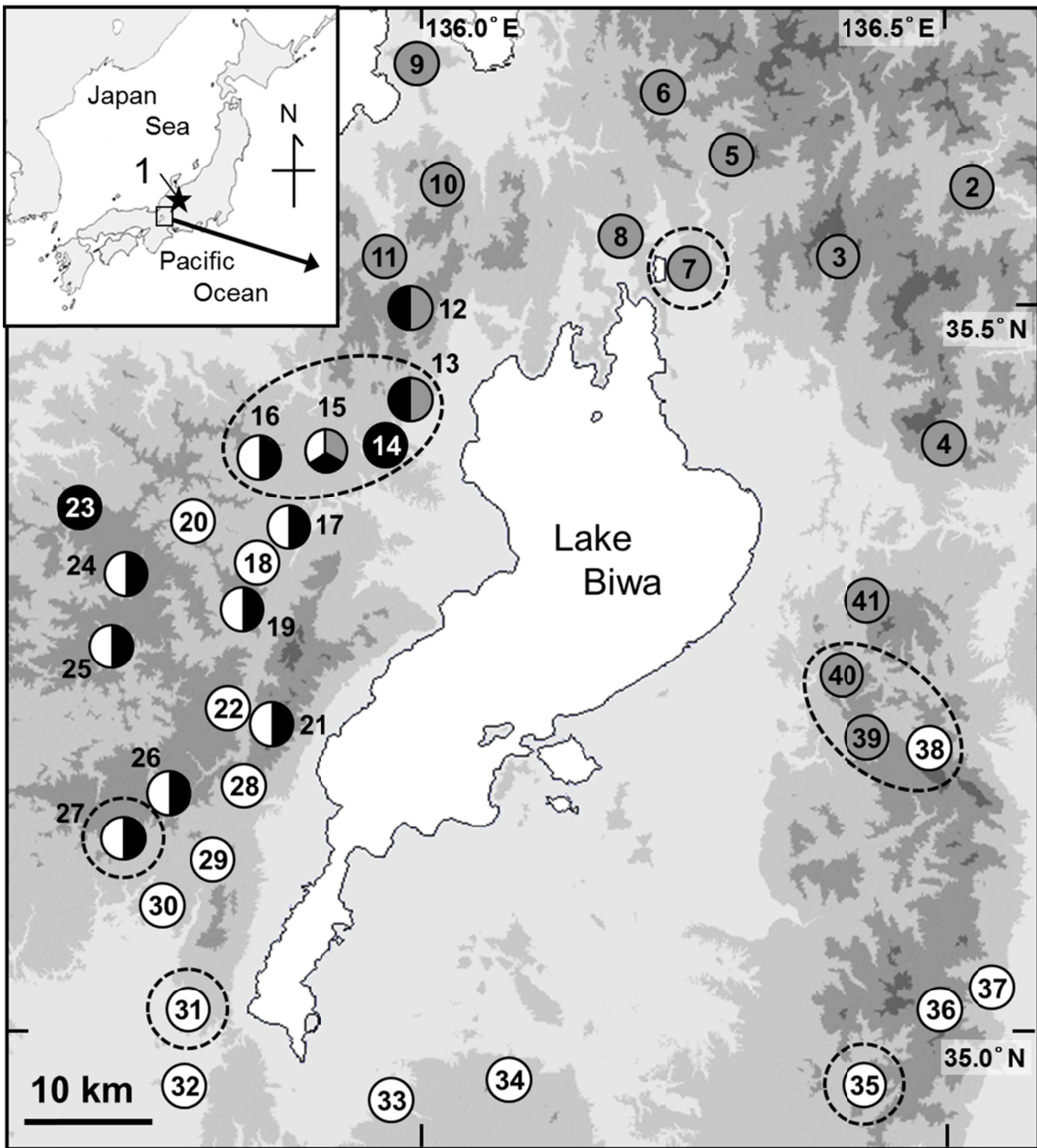

Figure 3-1



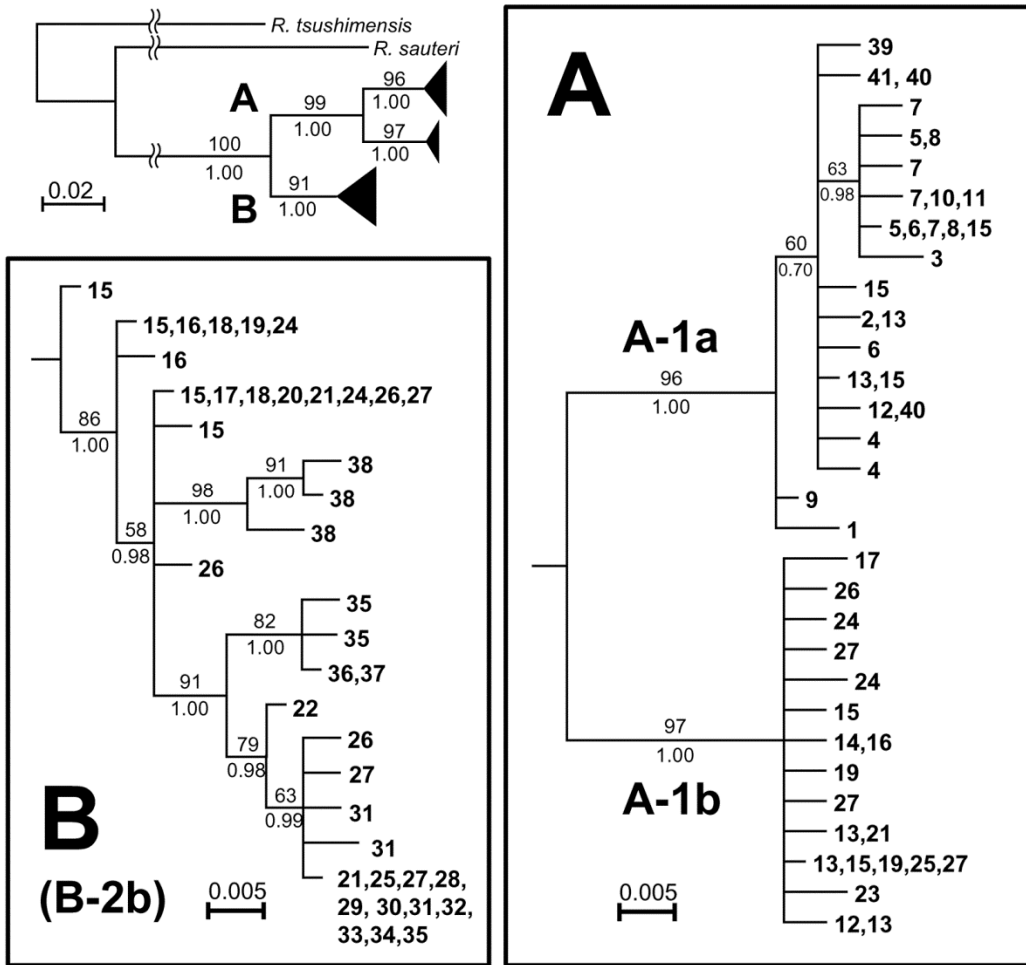

Figure 3-2



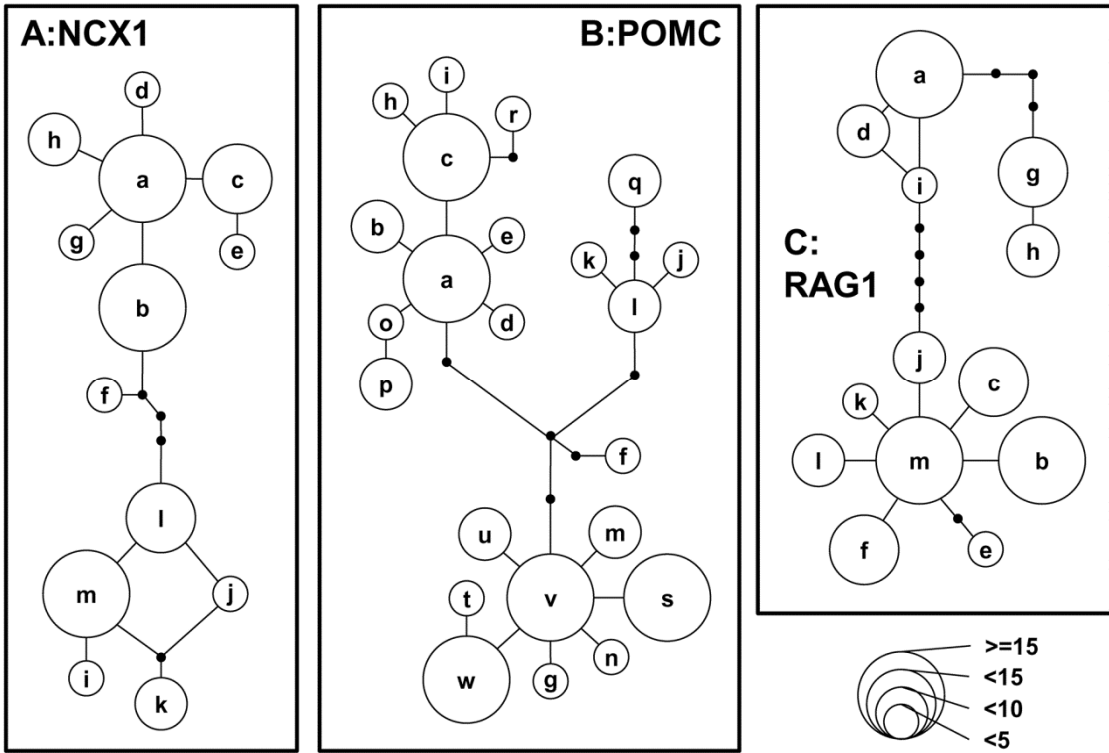
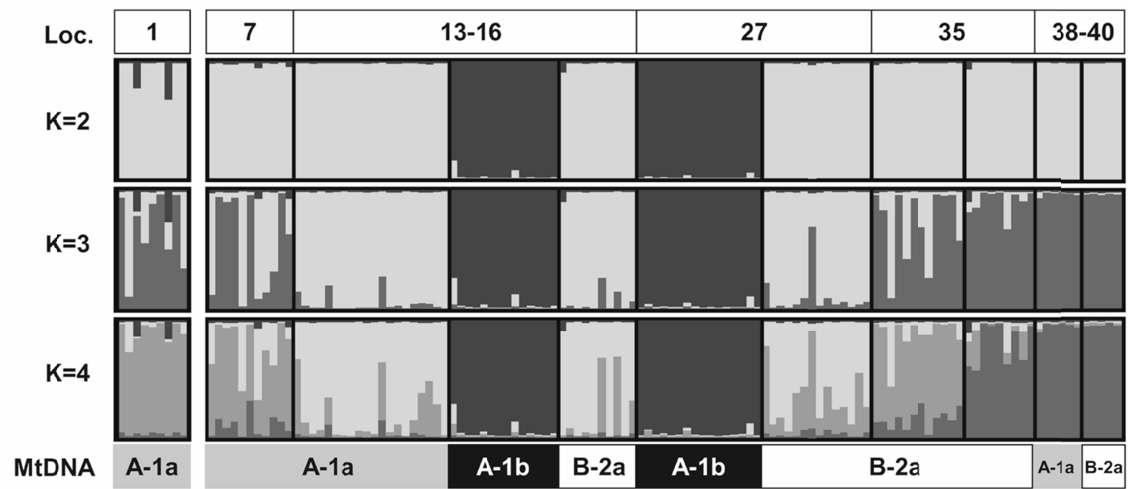

Figure 3-3







**Figure 3-4**



## CHAPTER 4

### Cytonuclear Discordance and Historical Demography of Two Brown Frogs *Rana tagoi* and *R. sakuraii*

#### 4-1 INTRODUCTION

*Rana tagoi* is known to breed in subterranean environment, which is quite unique reproductive ecology among brown frog species (Matsui & Matsui 1990; Maeda & Matsui 1999). This distinctive trait may be the product of adaptation to the highly mountainous environment of the Japanese archipelago. On the other hand, *R. sakuraii* breeds in the stream and the adult frogs have several characters suitable for highly lotic environment (e.g., possession of fully developed toe webs, which are more poorly developed in *R. tagoi*), although its eggs and larvae largely share traits with those of *R. tagoi*. These facts suggest that *R. sakuraii* speciated from a *R. tagoi*-like ancestor in adaptation to stream environment (Maeda & Matsui 1999). This hypothesis is supported by molecular phylogenetic analyses, in which *R. sakuraii* is totally embedded in *R. tagoi* lineages (Tanaka *et al.* 1996; Chapter 2). However, a part of *R. sakuraii* forms a clade with samples of *R. tagoi*, and neither of the two species are monophyletic in mitochondrial genealogy (Chapter 2). Because these previous studies analyzed only mtDNA, what process (e.g., introgression or incomplete lineage sorting [ILS] at the species level) caused this mutually paraphyletic pattern is undetermined. In this chapter, I analyzed sequence data of two mitochondrial and five nuclear loci to estimate phylogenetic relationships, divergence times, and demographic patterns of these two species, and discuss their speciation and evolutionary history.

#### 4-2 MATERIALS AND METHODS

##### 4-2-1 Sampling strategy

For each species, I chose samples belonging to representative localities/mt-lineages based on previous studies (Chapters 2 and 3). I analyzed 107 samples of *R. tagoi* (containing

each three samples of its subspecies *R. t. yakushimensis* Nakatani & Okada 1968 and *R. t. okiensis* Daito 1972 from peripheral islands) and 21 of *R. sakurii* from 81 localities of Japan, (Fig. 4-1, Table 4-1). In the phylogenetic analysis using mtDNA, I also added GenBank data of *R. kobai* (AB685768), *R. sauteri* (AB685767), *R. tsushimensis* (AB639592, AB639752), and *R. ulma* (AB685780) as outgroup taxa based on known phylogenetic relationships (Tanaka-Ueno *et al.* 1996, 1998).

#### 4-2-2 Sequencing of DNA

Total DNA was extracted from frozen or ethanol preserved tissues by standard phenol-chloroform extraction procedures. I then amplified fragments containing target region (two mitochondrial genes: 16S ribosomal RNA [*16S*] and NADH dehydrogenase subunit 1 [*ND1*]; five nuclear genes: sodium-calcium exchanger 1 [*NCX1=SLC8A1*], nuclear factor I/A [*NFIA*], pro-opiomelanocortin [*POMC*], sodium-calcium exchanger 3 [*SLC8A3*], and tyrosinase [*TYR*]) by polymerase chain reaction (PCR). The experimental conditions and techniques of PCR were essentially same as those reported in Chapter 2. The amplified PCR products were purified by polyethylene glycol (PEG) precipitation procedures. The cycle sequence reactions were carried out with ABI PRISM Big Dye Terminator v3.1 Cycle sequencing Kit (Applied Biosystems) and sequencing was performed on an ABI 3130 automated sequencer. I used the primers listed in Table 4-2 for PCR and sequencing, and all samples/loci were sequenced in both directions.

#### 4-2-3 Alignment of DNA, haplotype determination, and data characteristics

Sequence alignment was conducted using MUSCLE (Edgar 2004). For heterogenic nuclear genes, I used PHASE ver. 2.1 (Stephens *et al.* 2001) to determine haplotypes. In this analysis, the threshold of probability was set to small values (0.5–0.6) following Garrick *et al.* (2010). Before analyzing the historical demography, I also used IMgc (Woerner *et al.* 2007) to detect the largest non-recombining block of nDNA for IM analysis, because IMA2 assumes no intra-locus recombination (Hey & Nielsen 2004). As data parameters, I calculated the summary statistics of variable sites (*vs*), number of haplotypes (*h*), haplotype diversity (*Hd*), and nucleotide diversity ( $\pi$ ). I also checked neutralities of five nuclear loci with Tajima's *D* (Tajima

1989). Because none of them showed significant deviation from zero (Table 4-3), these loci were considered to be neutral markers. I conducted all these analyses by DnaSP (Rozas *et al.* 2003).

#### **4-2-4 Population assignment based on mtDNA**

Phylogenetic analysis was conducted using two mitochondrial genes. I first selected the best substitution model for each gene using Kakusan4 (Tanabe 2011) based on Akaike information criterion (AIC). Then phylogenetic trees based on maximum likelihood method (ML) and Bayesian inference (BI) were constructed using TREEFINDER ver. Mar. 2011 (Jobb 2011) and MrBayes ver. 3.2.1 (Ronquist & Huelsenbeck 2003), respectively. For ML tree, I conducted non-parametric bootstrap analysis with 1000 replicates, and branches with bootstrap value (BS) 70% or greater were regarded as significantly supported. In BI analysis, two independent runs of four Markov chains were conducted for 10 million generations (sampling frequency: one tree per 100 generations), then the first three million generations were discarded as burn-in. Convergence of parameters was checked using Tracer ver. 1.5 (Rambaut & Drummond 2009). I considered Bayesian posterior probability (BPP) 0.95 or greater as significant support. According to results of both analyses, I defined mitochondrial clades and lineages, which were treated as population units based on mtDNA in descendant analyses.

#### **4-2-5 Population assignment based on nDNA**

*Rana tagoi* and *R. sakuraii* are genetically so close as to cause difficulties in constructing phylogenetic trees using nDNA sequences (Chapters 2 and 3). Therefore, I alternatively conducted clustering analysis using STRUCTURE ver. 2.3.3 (Pritchard *et al.* 2000) to define population units based on nDNA. I applied admixture and allele frequency independent model to haplotype data of nuclear loci, and calculated a half million generations following 100,000 generations of burn-in. The number of cluster ( $K$ ) was set from 1 to 10, and 10 independent iterations were conducted for each  $K$ . The most likely number of  $K$  was determined by likelihood distribution of each iterations and delta  $K$  value (Evanno *et al.* 2005). I also constructed haplotype networks of each gene based on median joining method using Network ver. 4.6 (Bandelt *et al.* 1999) to examine the relationships among nuclear haplotypes.

#### 4-2-6 Divergence dating based on mtDNA

To estimate the divergence time between mt-lineages, I conducted Bayesian analysis using BEAST ver. 1.7.5 (Drummond *et al.* 2012). For each calibration, a total of 10 million generations of run (within which the first three millions were discarded as burn-in) were conducted under non-autocorrelated log-normal relaxed clock model. Tracer ver. 1.5 (Rambaut & Drummond 2009) was used to check parameter distributions and effective sample size (ESSs). I applied three different calibrations as follows:

Calibration I: I set a calibration point on the divergence of *R. kobai* from Amami Island and *R. ulma* from Okinawa Island (node O-1 in Fig. 4-2). The divergence time estimated for the separation of Amami and Okinawa populations of *Cynops ensicauda*,  $5.18 \pm 0.17$  MYA (Tominaga *et al.* 2013), was applied to this node. Although much younger divergence time was also proposed between populations/species of the two islands (e.g., 1.70 [2.40–1.10] MYA for *Odorrana amamiensis* and *O. narina*; 2.30 [3.20–1.50] MYA for *O. splendida* and *O. ishikawae*; Matsui *et al.* 2005), sequence divergence between *R. kobai* and *R. ulma* (4.7–5.3% in *16S*; Matsui 2011) is much larger than those of *Odorrana* species (e.g., 1.4–2.2% for *O. splendida* and *O. ishikawae*; Kuramoto *et al.* 2011), and older estimates of *Cynops* will be more plausible in this case.

Calibration II: The molecular evolutionary rate of 1.38% (0.69% per lineage) per MY was applied. This value was estimated for *ND1* and *ND2* regions of *Bufo* (Macey *et al.* 1998), and only *ND1* data were used in this calculation.

Calibration III: Using only *16S* data, I applied the evolutionary rate of 0.66% (0.33% per lineage) per MY estimated for *16S* of *Leiopelma* (Fouquet *et al.* 2009).

#### 4-2-7 Estimation of historical demography

The historical demography, especially patterns of gene flow and divergence times among species or genetic groups, was examined by coalescent analysis with Bayesian IM model. I analyzed nDNA data using the program IMA2 (Hey 2010), and estimated effective population sizes ( $N_e$ , calculated from population size parameter  $\theta$ ), migration rate parameters ( $m$ , calculated from migration rate  $M$ ), population migration rates ( $2N_eM$ , calculated from  $\theta$

and  $m$ ), and population divergence times ( $T$ , calculated from splitting time parameter  $t$ ). As the mutation rate of nuclear genes, I applied 0.047% per MY per lineage for *NCX1* (reported in the genus *Hydromantes*: Rovito 2010), 0.072 (0.061–0.083) % for *POMC* (*Hyperolius*: Lawson 2010), and 0.047 (0.027–0.067) % for *SLC8A3* (amphibians in general: Roelants *et al.* 2007). The geometric mean of these values, approximately  $2.71 \times 10^{-7}$  mutations per year per locus, was used as the mutation rate ( $\mu$ ) to scale each demographic parameter. Based on several test runs, upper bounds for parameters were set at  $\theta = 10$ –20,  $t = 3$ –5, and  $m = 10$ –25, and five million steps (sampling frequency: one tree per 50 steps) of calculations were performed for 30 heated chains after two millions of burn-in. I conducted three independent runs, and finally combined the results using L-mode option of IMA2. Because a majority of *R. tagoi* and *R. sakuraii* start to breed at the age of three years old (Kusano *et al.* 1995a; b), I applied this value as the generation time of the two species. Trendline plots and ESSs were monitored to ensure good mixing and convergence of parameters.

Significances of  $m$  and  $2N_eM$  were determined by the log-likelihood ratio (LLR) test of Nielsen & Wakeley (2001). I also used the parameter comparison option (with -p6 command) of IMA2 and output the list of probability, which indicates one parameter to be greater than the other. The relative strength of genetic isolation was evaluated by  $2N_eM$  values (strong [ $2N_eM \leq 1$ ], moderate [ $1 < 2N_eM \leq 5$ ], and weak [ $5 < 2N_eM \leq 25$ ]: Wright 1931; Waples & Gaggiotti 2006; Reilly *et al.* 2012).

## 4-3 RESULTS

### 4-3-1 Sequence characteristics

I obtained complete sequences of mitochondrial *16S* (1612bp) and *ND1* (967bp) for all samples. Parsimoniously informative sites within the ingroup were 489bp in total (244 for *16S* and 245 for *ND1*). The other statistics are listed in Table 4-3.

In the sequences of five nuclear loci for all 128 samples, only *POMC* had insertion-deletion sites, and these sites were omitted in the following analyses. In the haplotype determination using PHASE, all haplotypes in all samples/loci were successfully determined except for one sample for *POMC* and two for *TYR*, which were treated as null allele in descendant analyses. The sequence length and statistics of each locus are listed in Table 4-3.

Overall, each locus generally showed large parameter values, indicating great genetic diversity in *R. tagoi* and *R. sakurarii*. Among five nuclear loci, *TYR* was most variable ( $Hd = 0.955$  and  $\pi = 0.017$  for overall samples) and *NFIA* was least variable (0.735 and 0.003, respectively).

#### **4-3-2 Population assignment: Mitochondrial DNA results**

The best substitution model selected in ML analysis was general time reverse (GTR: Tavaré 1986) model with a gamma shape parameter (G) of 0.158 and a proportion of invariable sites (I) of 0.144 for *I6S* and J1 (Jobb 2011) model + G (0.543) + I (0.312) for *ND1*. In BI, GTR + G (0.082) + I (0.226) and GTR + G (0.892) + I (0.226) for *I6S* and *ND1*, respectively. Constructed ML ( $-\ln L = 15500.618$ ) and BI (15863.190) trees were essentially identical in topology, and only ML tree is shown in Fig. 4-2. I followed Chapter 2 for names of each genetic group.

The phylogenetic relationships obtained were fundamentally same as those already reported (Chapter 2). The ingroup was divided into two large clades (A and B), and both of them included several lineages (A-1ab to A-9abc and B-1 to B-2ab); Clade B (ML-BS = 82% and BPP = 1.00) contained only *R. tagoi* samples, while Clade A (ML-BS = 93% and BPP = 1.00) included both the *R. tagoi* and *R. sakurarii* samples. Monophyly of each clade/lineage was also well supported (ML-BS  $\geq$  70%, BPP  $\geq$  0.95). Statistical supports for nodes were generally better than in the previous study, and more detailed phylogenetic relationships were clarified. Especially the relationships among lineages in Clade A became clear. In Clade A, lineages from Honshu Island (A-1ab to A-6) formed a subclade (A' in Fig. 4-2. ML-BS = 73% and BPP = 0.98) against Shikoku and Kyushu subclade (A''). ML-BS = 79% and BPP = 0.95). Within Subclade A', further three lineage groups were recognized: the group consisted of Lineages A-1a and A-1b (ML-BS = 82% and BPP = 1.00); Lineages A-2 and A-3 (ML-BS = 70% and BPP = 0.98); Lineages A-4, A-5, and A-6 (ML-BS = 79% and BPP = 1.00). Samples identified as *R. sakurarii* were included in Lineages A-2 and A-3. Lineages A-2 also contained *R. tagoi* samples (i.e., neither of two species were monophyletic), although haplotypes were not shared between the two species.

#### **4-3-3 Population assignment: Nuclear DNA results**



Results of clustering analysis using STRUCTURE are shown in Fig. 4-3. For overall samples,  $K = 2$  was supported by the test of delta  $K$ , and two clusters (I and II) were recognized. Almost all samples were clearly assigned to each cluster (posterior probabilities  $\geq 80\%$ ), indicating the presence of strong genetic isolation between two nDNA clusters. Although the division of two nuclear clusters (I and II) did not completely correspond to that of two mitochondrial clades (A and B), Cluster II was largely concordant with mitochondrial Subclade A' except for Lineage A-1a (Fig. 4-3). Clusters I and II also tended to be separated on haplotype networks of some nuclear genes (e.g., *NCX1*, *NFIA*, and *SLC8A3*; Fig. 4-4). However, in relatively more variable genes like *TYR*, the relationships of haplotypes were highly complicated and separation of the clusters was not clear (Fig. 4-4).

Because the two large clusters obtained seemed to contain several subclusters, I independently reanalyzed samples for the two clusters. In this analysis I excluded some samples that could not be clearly assigned in the overall analysis as mentioned above (posterior probabilities  $< 80\%$ ). Within Cluster I, the population assignment with  $K = 2$  was supported (Fig. 4-3). In this clustering, division of subclusters was still roughly correlated with mt-lineages: lineages from main islands (A-1a, A-7, A-9a, and B-2ab) tended to form a subcluster, and lineages from peripheral islands (A-8, A-9c, and B-1) formed another. One lineage, A-9b, included samples assigned to both of these subclusters. Except for Lineage A-9b, samples of the two subclusters were clearly assigned to either subcluster. On the other hand,  $K = 3$  was supported for Cluster II by delta  $K$  test and likelihood distribution. In this division, each of *R. tagoi* Lineages A-1b and A-4, *R. tagoi* A-2, and *R. sakurarii* (A-3 and a part of A-2) formed a unique subcluster (Fig. 4-3). Separation of these subclusters was complete (posterior probabilities  $> 80\%$ ), with few exceptional samples in the *R. sakurarii* subcluster. In contrast, a large portion of samples of lineages A-5 and A-6 was not clearly assigned to particular subclusters, and showed intermediate genetic structures between *R. tagoi* of A-2 and *R. sakurarii*. In the larger  $K$  value like  $K = 4$ , Lineages A-1b and A-4 were separated.

#### **4-3-4 Divergence times of mitochondrial lineages**

Results of divergence dating for major nodes in the mitochondrial genealogy are listed in Table 4-4. Divergence times obtained for ingroup were similar in the three calibrations,

although estimated ages tended to be younger in Calibration I and older in III. Two major mt-clades (A and B: node 1 in Fig. 4-2) were estimated to have diverged at 4.2–3.0 (95% highest posterior density interval [HPD] of 6.2–2.3) MYA. Then Subclades A' and A'' (node 2) were split at 2.8–2.0 (4.1–1.1) MYA, followed by the separation within Clade B (node 22) at 2.7–1.9 (4.3–0.9) MYA. Two lineages including *R. sakuraii* samples, A-2 and A-3, were separated from each other at 2.1–1.6 (3.1–0.8) MYA (node 7), followed by internal divergence during 1.4–0.8 (2.2–0.4) MYA (nodes 8 and 9). The most recently divergent lineages were B-2a and B-2b (node 23), which were split at 1.4–1.0 (2.2–0.5) MYA. These estimates indicate that the divergence of each mitochondrial clade/lineage has begun around the middle to the late Pliocene and nearly completed at the middle Pleistocene.

#### 4-3-5 Historical demography

As shown above, results of population assignment were not completely concordant between mt- and n-DNA (Figs. 4-2 and 4-3). In estimating demographic parameters, I used only nDNA data because nuclear marker is thought to be more conservative than mitochondrial one, which is more likely to be affected by introgressions than the nuclear marker (Ballard & Whitlock 2004).

First, I conducted a coalescent analysis using IMA2 for the two large nuclear clusters I and II. Each parameter showed single peaks in their probability density distributions (Fig. 4-5). Parameter values obtained are listed in Table 4-5. Estimated migration parameter ( $m$ ) and population migration rate ( $2N_eM$ ) for I to II ( $I > II$ ) were 0.16 (95%HPD of 0.07–0.35) and 0.52 (0.24–1.12), respectively. In the opposite direction,  $II > I$ , values of these parameters tended to be larger, with  $m_{II>I}$  being 0.30 (0.17–0.53) and  $2N_eM_{II>I}$  being 1.23 (0.70–2.14). The LLR test showed all these values to be significantly larger than zero ( $p < 0.01$ ), suggesting clusters I and II to have kept a certain degree of gene flow after their divergence. However, strong to moderate genetic isolation would exist between the two clusters, because  $2N_eM$  values obtained were relatively small (around 1 or smaller: Wright 1931; Waples & Gaggiotti 2006; Reilly *et al.* 2012). In the migration parameter for each direction,  $m_{II>I}$  was shown to be larger than  $m_{I>II}$  (posterior probability  $> 0.95$ ). Effective population size estimated for I, II, and their ancestor was 2.2 (1.7–2.9), 1.7 (1.3–2.3), and 0.4 (0.2–0.8) million individuals,

respectively. The ancestral population size was smaller than the present ones, as supported by parameter comparison of  $\theta$  (posterior probabilities were 1.00 for each comparison). The population size of II tended to be smaller than that of I, but the tendency was not supported statistically (BPP < 0.95). The population divergence time ( $T$ ) of I and II was estimated as 2.7 (4.4–2.2) MYA. Although its 95%HPD was relatively wide, this estimate was younger than the divergence time of two major mt-clades (A/B: ca. 4.2–3.0 MYA) but nearly equal to those of A'/A'' (ca. 2.8–2.0 MYA) and B-1/B-2 (ca. 2.7–1.9 MYA) (Table 4-4).

I then estimated demographic parameters between *R. tagoi* and *R. sakurarii*. As *R. tagoi*, I chose mt-lineages of A-2, 5, and 6, that were genetically close to *R. sakurarii* in the mitochondrial and nuclear DNA analyses as shown above (see Figs. 4-2 and 4-3). Because present data set would be not sufficiently informative to analyze four populations model, I combined Lineages A-5 and A-6 as a single group; they are phylogenetically close (Fig. 4-2) and united in nDNA analysis (Fig. 4-3). I applied two different schemes to the topology of population tree for the three groups (*R. sakurarii*/*R. tagoi* of A-2/*R. tagoi* of A-5 and 6). In Scheme 1, *R. sakurarii* ( $R_s$ ) and *R. tagoi* ( $R_t$ ) Lineage A-2 are assumed to be mutually close against A-5 and 6, based on the mtDNA genealogy, and in Scheme 2, *R. tagoi* A-2 and A-5+6 form a group based on the current taxonomy.

Resultant estimates of  $m$ ,  $N_e$ , and  $2N_eM$  for the three groups were fundamentally similar in the two schemes (Fig. 4-6 and Table 4-5). Significant gene flow ( $p < 0.01$  in LLR test) was detected in A-5+6 to *R. tagoi* A-2 ( $m_{A-5+6 > A-2R_t}$  was 3.61 [0.79–10.26] in Scheme 1 and 4.81 [3.04–7.52] in Scheme 2) and in A-5+6 to *R. sakurarii* in Scheme 2 ( $m_{A-5+6 > R_s}$  of 1.17 [0.45–2.90]). Of these values,  $m_{A-5+6 > A-2R_t}$  was larger than all the others in both schemes (BPP > 0.95). Some other combinations also showed relatively large migration estimates (e.g.,  $m_{A-5+6 > R_s}$  of 0.91 [0.14–4.31] in Scheme 1), but were not supported statistically ( $p > 0.05$ ). Similar tendency was also recognized in  $2N_eM$  parameters, and only  $2N_eM_{A-5+6 > A-2R_t}$  (6.68 [3.56–21.31] in Scheme 1 and 5.31 [3.68–9.58] in Scheme 2) and  $2N_eM_{A-5+6 > R_s}$  (0.95 [0.36–1.93] only in Scheme 2) were supported statistically ( $p < 0.05$ ). These  $2N_eM$  values indicated the genetic isolation between *R. tagoi* A-2 and A-5+6 to be weak ( $5 < 2N_eM$ ), but gene flow was strongly biased to one direction (from A-5+6 to A-2). The degree of isolation between *R. sakurarii* and *R. tagoi* A-5+6 was strong to moderate in Scheme 2, in agreement with no

significant gene flow in Scheme 1. In other combinations, gene flows between species/lineages were limited, indicating their strong genetic isolation. Estimated effective population sizes (million individuals) were nearly same between *R. tagoi* A-2 (0.80 [0.34–2.06] in Scheme 1 and 0.86 [0.35–2.07] in Scheme 2) and A-5+6 (0.79 [0.38–1.76] and 0.86 [0.41–1.96]), but were smaller in *R. sakurii* (0.15 [0.07–0.31] and 0.16 [0.05–0.32]).

In contrast to these parameters, estimated  $m$  and  $2N_eM$  between ancestral populations were more or less different between the two schemes. In Scheme 2, large gene flow ( $p < 0.05$ ) was detected between ancestral populations of *R. sakurii* and *R. tagoi* A-2+5+6 in both directions ( $m_{R_s > A-2+5+6}$  and  $2N_eM_{R_s > A-2+5+6}$  were 18.05 [6.50–24.64] and 10.86 [8.34–64.80], respectively, and,  $m_{A-2+5+6 > R_s}$  and  $2N_eM_{A-2+5+6 > R_s}$  were 13.90 [1.76–24.75] and 5.71 [0.82–8.05], respectively), whereas no obvious peaks of probability for these parameters were recognized in Scheme 1 (Fig. 4-6 and Table 4-5). Genetic isolation between ancestral populations was evaluated as weak in Scheme 2 ( $2N_eM > 5$ ) and strong in Scheme 1 ( $2N_eM \leq 1$ ). The effective population size estimated for *R. sakurii* + *R. tagoi* A-2 (0.26 [0.03–1.19]; Scheme 1) was similar to that of *R. tagoi* A-2+5+6 (0.30 [0.05–3.60]; Scheme 2). The estimated size for the ancestor of all three groups was larger in Scheme 1 (0.43 [0.23–0.77]) than in Scheme 2 (0.26 [0.04–1.77]). Estimated  $N_e$  for the ancestor all tended to be smaller than present  $N_e$  for *R. tagoi* (A-2, A-5+6) and larger than that for *R. sakurii*, but the tendencies were not supported statistically (BPP < 0.95). Population divergence time estimated was younger for *R. sakurii*/*R. tagoi* A-2 (0.88 [3.90–0.42] MYA; Scheme 1) than for *R. tagoi* A-2/A-5+6 (1.12 [1.67–0.77] MYA; Scheme 2). In Scheme 1, much older (1.80 [4.52–0.96] MYA) estimate for split of ancestral *R. sakurii*, *R. tagoi* A-2 and *R. tagoi* A-5+6 was obtained, but no reliable estimate was obtained in Scheme 2.

## 4-4 DISCUSSION

### 4-4-1 Discordance between classification and pattern of genetic variation based on different markers

In this study, the phylogenetic pattern similar to that reported in previous studies using mtDNA (e.g., Chapter 2) was obtained. *Rana sakurii* was embedded in *R. tagoi*, and both of them were not monophyletic in the mitochondrial genealogy. *Rana sakurii* formed a unique

lineage (Lineage A-3) within one of the two major clades (Clade A) containing the two species, although it also formed another lineage with *R. tagoi* (A-2). To explain such a phylogenetic pattern, I inferred past mitochondrial introgression between the two species in Chapter 2, but in the previous chapter I analyzed only mtDNA and could not discuss the issue further. These two lineages, A-2 and A-3, showed sister relationships in the present analysis (Fig. 4-2). Thus, the following three different scenarios can be proposed to explain this phylogenetic pattern: (1) recent speciation of *R. sakurarii* from *R. tagoi*, which led ILS of mtDNA at the species level; (2) past mitochondrial introgression from *R. tagoi* to *R. sakurarii*; and (3) the opposite direction of introgression (Fig. 4-7). If the recent separation between *R. sakurarii* and *R. tagoi* was the case, ILS hypothesis would be supported. But if the speciation was shown to be old (especially much older than the divergence time within Lineage A-2), this hypothesis will be rejected. In contrast, past introgression hypothesis would be supported when the significant historical gene flow was detected between the two species, although this is not exclusive evidence for ILS.

The obtained genetic relationship based on structure analysis using nDNA discorded with mitochondrial genealogy, and samples of *R. sakurarii* and *R. tagoi* (Lineage A-2) tended to be separated in different subclusters (Fig. 4-3). This result should reflect their heterospecific status. The demographic analysis based on coalescent theory showed that the historical gene flow between *R. sakurarii* and *R. tagoi* A-2 was limited, with the time of their separation (ca. 0.9 MYA in Scheme 1: Table 4-5) younger than the separation of A-2 and A-3 (ca. 2.1–1.6 MYA: Table 4-4), and similar to or still younger than the divergence within these lineages (ca. 1.4–0.8 MYA). These results seem to be concordant with ILS hypothesis.

Compared to results obtained in IM analysis of Scheme 1, estimated divergence time was relatively old or unreliable in Scheme 2 (Table 4-5), in which *R. tagoi* A-2 was presumed to be closer to other *R. tagoi* lineages (A-5, 6) than to *R. sakurarii*. In contrast, significant historical gene flow between ancestral populations was not detected in Scheme 1, but large mutual migration was estimated in Scheme 2 ( $2N_eM > 5$  in both directions: Table 4-5). These results suggest that the assumption about ancestral population in Scheme 2 is incorrect, and Scheme 1, which assumes sister relationship of *R. tagoi* A-2 and *R. sakurarii*, would be more plausible. Therefore, the mutually paraphyletic relationships of two species on mitochondrial genealogy are thought to be caused by ILS resulted from recent speciation of *R. sakurarii* from

*R. tagoi*.

The estimated time of split of the two species (ca. 0.9 MYA) is younger than those of other Japanese frog lineages (e.g., ca. 2.3 MYA in *O. ishikawae/O. splendida* and ca. 1.7 MYA in *O. amamiensis/O. narina*: Matsui *et al.* 2005; around 4.0 MYA in *B. torrenticola/B. japonicus*: Igawa *et al.* 2006), and seems to have occurred after the rough formation of the Japanese archipelago (see next section). Although ILS of mtDNA at the species level is relatively rare because of its small effective number of gene copy, it occasionally happens in some situations such as rapid, sympatric speciation (Funk & Omland 2003). It could be applicable in the case of *R. sakuraii* and *R. tagoi*, because they show sympatric distribution in wide range keeping isolation in breeding habitats. *Rana sakuraii* has several traits adaptive to stream breeding in contrast to subterranean breeding *R. tagoi*, although they share many other characters (Matsui & Matsui 1990). This indicates that the speciation of *R. sakuraii* was triggered by adaptation to a new breeding habitat, which is a process which often promotes rapid speciation (Coyne & Orr 2004).

#### **4-4-2 Evolutionary history of two species**

*Rana tagoi* and *R. sakuraii* are endemic to the Japanese archipelago and no close relatives have been known from the continent, although *R. sauteri*, another lotic breeding brown frog from Taiwan, is thought to be their sister lineage (Tanaka-Ueno *et al.* 1998). Present result did not conflict with this idea, although their divergence was estimated to be old (22.0–11.6 [36.0–5.7] MYA: Table 4-4), around the middle Miocene. Because continental allies of *R. sauteri* are also unknown, invasion route of the ancestor of *R. tagoi* and *R. sakuraii* to the Japanese mainlands is uncertain. Two species do not occur in Hokkaido and central to southern Ryukyus, and genetic diversity in *R. tagoi* is lower in northern Honshu than in central to western part of Japan. Thus the ancestral population is suspected to have invaded from southern area including the present Taiwan and the Ryukyu regions, which was a vast land and not yet separated from the continent in the middle Miocene (Chinzei & Machida 2001), or have entered from the Korean peninsula to northern Kyushu via the Tsushima land bridge, which often connected the Eurasian continent and Japanese archipelago since ca. 11 MYA (Iijima & Tada 1990). In each hypothesis, ancestral brown frogs possibly distributed in the continent or the Ryukyus would

have already extinguished, leaving the relict species in Japan and Taiwan.

In any case, ancestral population is thought to have been split into two major Clades, A and B, in the middle to late Pliocene (ca. 4.2–3.0 MYA). The ancient Japanese archipelago was already roughly formed by the late Miocene (Chinzei & Machida 2001), and the separation of clades is thought to have occurred on the archipelago. The ancestor at this period would have been a *R. tagoi*-like subterranean breeder because all the present species/lineages have a common larval trait (e.g., no need to feed until metamorphosis) that is thought to have derived in such an environment. The ancestral effective population size (ca. 0.4 million individuals for the ancestor of nuclear clusters I and II: Table 4-5) estimated in IM analysis is much smaller than the present one (ca. 3.9 million individuals for sum of I and II: Table 4-5), indicating relatively small original population size.

Then in the late Pliocene to the early Pleistocene (ca. 2.0–2.8 MYA), the separation of Subclades A' and A'' occurred, and nearly simultaneously, Clusters I and II split (ca. 2.7 MYA). The division of nu-Clusters I and II largely corresponded to division of mt-Subclade A' and the others, although there was one exceptional lineage (A-1a). Lineage A-1a was an internal lineage of Subclade A', while it was included in Cluster I (Figs. 4-2 and 4-3). This lineage, however, is thought to be generated by introgression of mtDNA from A-1b (included in Cluster II) to B-2a (Cluster I) (Chapter 3). Present results of IM analysis (Table 4-5) supported the existence of historical gene flow between Clusters I and II (especially from II to I), which is congruent with this hypothesis. Thus the n-Cluster II is thought to have originated together with mt-Subclade A', then the mitochondrial introgression from II to I would have occurred around 1.8–1.4 MYA (the divergence time of A-1a and A-1b). Divergences of A', A'', and B have started around 2.7–1.8 MYA, before the split of present mt-lineages by the middle Pleistocene (around 1.4–1.0 MYA). In this period, populations on peripheral islands were isolated geographically, and some survived and evolved to be present subspecies, i.e., *R. t. yakushimensis* of Lineage A-8 and *R. t. okiensis* of B-1.

The date of speciation of *R. sakurarii* was estimated to be younger than the formation of major mt-lineages, and the event would have occurred around 0.9 MYA based on IM analysis (Table 4-5), probably in association with the adaptation to a new breeding environment as discussed above. The effective population size of *R. sakurarii* (ca. 0.2 million individuals) is

smaller than in the closest mt-lineage of *R. tagoi* (ca. 0.8 for Lineage A-2), and suggests that small-sized ancestral population adapted for stream breeding led to *R. sakurii*. Although the place of the origin of *R. sakurii* is unknown, it could have been somewhere in central Honshu, where the distributional boundary of two *R. sakurii* mt-lineages (A-2 and A-3) occurs. Further studies such as estimation of population dispersal patterns, and comparison of the patterns obtained with geohistorical information, would elucidate more definite evolutionary history of *R. sakurii*.

#### 4-4-3 Taxonomic implications

As is clear from previous and present studies, *R. tagoi* and *R. sakurii* have complicate genetic relationships and can be regarded as forming a species complex. In this complex, taxonomy of diversified lineages is far from complete. However, present results of nDNA analyses provided some insights into the taxonomy of this complex.

*Rana tagoi* (sensu lato, including subspecies and cryptic taxa) and *R. sakurii* were divided into several clusters/subclusters in the structure analysis, whereas they were also split into numerous clades/lineages in the mtDNA analysis (Figs. 4-3 and 4-2). Because mt-Lineage A-1a and the main islands subcluster within n-Cluster I included topotypic samples of *R. tagoi* (loc. 25), this lineage/subcluster should be true *R. t. tagoi* (*R. t. tagoi* sensu stricto). Other genetic groups already have names include *R. sakurii* (Lineages A-2 and A-3; *R. sakurii* subcluster in Cluster II), *R. t. yakushimensis* (Lineage A-8 in Cluster I), and *R. t. okiensis* (Lineage B-1 in Cluster I).

Taxonomic status of the remaining lineages/subclusters were not fixed in the present study, but Lineage A-1b should be a cryptic species (= *R. t. tagoi* “small type” in Sugahara 1990), because it forms a unique subcluster in Cluster II (but together with Lineage A-4: Fig. 4-3) isolated from sympatric samples of *R. t. tagoi* (Lineages A-1a [*R. t. tagoi* sensu stricto] and B-2a) and *R. sakurii* (Lineage A-3). Lineage A-2 of *R. t. tagoi* also tended to form a unique subcluster in Cluster II, and seemed to be genetically isolated from sympatric *R. sakurii* (Lineages A-2 and A-3) and *R. t. tagoi* sensu stricto (Lineage A-1a). On the other hand, *R. t. tagoi* Lineage A-6 has been considered as a cryptic taxon of *R. tagoi* based on karyological evidence (Ryuzaki *et al.* 2006), but their uniqueness was not supported in nDNA



analyses. Demographic parameters obtained in IM analysis showed relatively large migration rate between Lineages A-5/A-6 and A-2 of *R. t. tagoi* (although it was strongly biased to the direction from A-5/A-6 to A-2), and status of these lineages is still unclear. Other lineages/subclusters, which might be also cryptic taxa, are as follows: Lineage A-4 of *R. t. tagoi* from Honshu, which seems to be genetically isolated from sympatric *R. sakurii* (Lineage A-2) and *R. t. tagoi* sensu stricto (A-1a), although it was included in the subcluster together with A-1b within Cluster II ( $K = 3$  for Cluster II in Fig. 4-3); and Lineage A-9c of *R. t. tagoi* from Goto Islands, which was isolated from populations of main islands but was close to peripheral subspecies in nDNA analysis ( $K = 2$  for Cluster I in Fig. 4-3).

In contrast to these genetic groups, some populations of *R. t. tagoi* were separated in mtDNA genealogy but integrated in nDNA analysis. For example, each of lineages A-1a, A-7, A-9a, and B-2ab diverged in mitochondrial genealogy, but altogether formed a single nuclear subcluster within Cluster I ( $K = 2$  for cluster I in Fig. 4-3). Although they were subdivided in larger  $K$  schemes, the division was not clear and seemed to be clinal ( $K = 3$  for Cluster I in Fig. 4-3). Relatively young origin of *R. sakurii* estimated in IM analysis suggested that taxonomic units in the *R. tagoi* species complex, in particular sympatrically occurring ones, have arisen recently. So it is possible that some of them still do not form a monophyletic group in mitochondrial genealogy, as is the case with *R. sakurii*. In addition, each of *R. sakurii*, *R. tagoi*, and its cryptic taxa was not clearly separated in the haplotype networks of five nuclear loci (Fig. 4-4). This should be largely because of the ILS of nDNA, which evolves much slower than mtDNA. These facts imply that mitochondrial and nuclear monophyly is not simply be adopted in classifying this species complex, but more inclusive studies containing detailed population assignment and comparisons of morphological/ecological traits are needed to fix the taxonomic status of lineages/clusters contained.

Present results of nDNA might not have achieved sufficient resolution for the genetic structure, because there were still more probable subdivisions of each cluster in the  $K$  values larger than those supported by the delta  $K$  test (Fig. 4-3). This is also suggested from taxonomic viewpoints. For example, two island subspecies *R. t. yakushimensis* and *R. t. okiensis* are isolated geographically and differentiated morphologically/phylogenetically from each other (Fig. 4-2), but they were allied to a single subcluster within the Cluster I (Fig. 4-3).

This may possibly be because the data set in the present study was not sufficient to detect detailed genetic structure of this group. Thus further studies using greater number of genetic markers as well as different methods (e.g., a large data set of SSRs and/or SNPs) may clarify much finer diversification patterns in the *R. tagoi* species complex.

## FIGURE LEGENDS

**Fig. 4-1.** Sampling localities. Distributional ranges of each mitochondrial lineage of *R. tagoi* (solid lines) and *R. sakurarii* (broken lines) were modified from Chapter 2. Lineages of *R. sakurarii*, *R. t. okiensis*, and *R. t. yakushimensis* were indicated by *Rs*, *Rto*, and *Rty*, respectively, and the others are *R. t. tagoi* lineages.

**Fig. 4-2.** Maximum likelihood tree based on complete sequences of mitochondrial *16S* and *ND1* (2579 bp in total) for *Rana tagoi* and *R. sakurarii*. For locality numbers, refer to Fig. 4-1.

**Fig. 4-3.** Results of STRUCTURE analyses based on five nuclear genes. Each mitochondrial lineage is separated by black vertical lines. (top) The best clustering result ( $K = 2$  clusters) for whole 128 samples; (left bottom) Results with  $K=2$  (best) and 3 for Cluster I; (right bottom) Results with  $K=3$  (best) and 4 for Cluster II. Hatched lines indicate individuals excluded in the analysis.

**Fig. 4-4.** Median-joining networks of five nuclear loci. The size of each circle reflects the relative sample size of each haplotype. The color indicates nuclear clusters and species as follows: red = n-Cluster I of *R. tagoi*; green = n-Cluster II of *R. tagoi*; light green = n-Cluster II of *R. sakurarii*. Black circles and bars indicate median vectors and missing haplotypes, respectively.

**Fig. 4-5.** Posterior probability densities for divergence time ( $T$ ), effective population size ( $N_e$ ), and population migration rate ( $2N_eM$ ) of cluster I and II obtained by IM analyses. Resultant values and 95% confidence intervals for each estimate are listed in Table 4-5.

**Fig. 4-6.** Posterior probability densities for divergence time ( $T$ , left top), effective population size ( $N_e$ , left middle and bottom) and population migration rate ( $2N_eM$ , right top, middle, and bottom) of *R. tagoi* (*Rt*) lineage A-2, A-5+6, and *R. sakurarii* (*Rs*). Parameters obtained in Scheme 1 and 2 are respectively shown as triangle and circle markers. Estimates with no

statistical support were indicated by *ns*. Resultant values and 95% confidence intervals for each estimate are listed in Table 4-5.

**Fig. 4-7.** Hypothesized scenarios which caused mitochondrial paraphyly of two species. (1) Species level ILS hypothesis. (2) Past mitochondrial introgression hypothesis, in which introgression occurred from *R. tagoi* to *R. sakurarii* (a) or the opposite direction (b). Solid and broken lines indicate mt-lineages of *R. tagoi* and *R. sakurarii*, respectively. Grey arrows indicate massive mitochondrial introgression.

**Table 4-1.** Samples used in present study with the information of sampling localities and vouchers. KUHE: Graduate School of Human and Environmental Studies, Kyoto University; TMP: Temporary numbered.

| loc.<br>nos.            | locality                              | voucher<br>(KUHE) | mt-lineage |
|-------------------------|---------------------------------------|-------------------|------------|
| <i>Rana tagoi tagoi</i> |                                       |                   |            |
| 1                       | Mutsu City, Aomori Pref.              | 44827             | A-1a       |
| 2                       | Noshiro City, Akita Pref.             | 46598             | A-1a       |
| 3                       | Ichinoseki City, Iwate Pref.          | 36699             | A-1a       |
| 4                       | Sendai City, Miyagi Pref.             | 45622             | A-1a       |
| 5                       | Yamagata City, Yanagata Pref.         | 37543             | A-1a       |
| 6                       | Nihonmatsu City, Fukushima Pref.      | 29595             | A-1a       |
| 7                       | Nihonmatsu City, Fukushima Pref.      | 36330             | A-2        |
| 8                       | Daigo town, Ibaraki Pref.             | 42344             | A-1a       |
|                         |                                       | 43723             | A-1a       |
|                         |                                       | 43886             | A-2        |
|                         |                                       | TMP_081122-1      | A-2        |
| 9                       | Tsukuba City, Ibaraki Pref.           | 42747             | A-2        |
| 10                      | Ichihara City, Chiba Pref.            | 28409             | A-2        |
|                         |                                       | 46172             | A-2        |
| 11                      | Kanuma City, Tochigi Pref.            | 40166             | A-1a       |
| 12                      | Uonuma City, Nigata Pref.             | 36896             | A-1a       |
| 13                      | Nakanojo Town, Gunma Pref.            | 44810             | A-1a       |
|                         |                                       | 44811             | A-1a       |
|                         |                                       | 22930             | A-4        |
|                         |                                       | 22936             | A-4        |
|                         |                                       | 44797             | A-4        |
| 14                      | Saku City, Nagano Pref.               | 43980             | A-2        |
| 15                      | Akiruno City, Tokyo Pref.             | 42452             | A-2        |
|                         |                                       | 42453             | A-2        |
| 16                      | Fujikawaguchiko Town, Yamanashi Pref. | 45558             | A-2        |
|                         |                                       | 43480             | A-6        |
| 17                      | Minobu Town, Yamanashi Pref.          | 45552             | A-2        |
|                         |                                       | 45549             | A-6        |
| 18                      | Izu City, Shizuoka Pref.              | 43468             | A-2        |
| 19                      | Hokuto City, Yamanashi Pref.          | 43483             | A-5        |
| 23                      | Nagano City, Nagano Pref.             | 18005             | A-5        |
| 24                      | Kurobe City, Toyama Pref.             | 45102             | A-1a       |
|                         |                                       | 45103             | A-1a       |
|                         |                                       | 45014             | A-5        |
|                         |                                       | 45099             | A-5        |
| 25                      | Takayama City, Gifu Pref.             | 42048             | A-1a       |
|                         |                                       | 43018             | A-1a       |
| 26                      | Gujo City, Gifu Pref.                 | 14228             | A-5        |
| 27                      | Fujieda City, Shizuoka Pref.          | 17955             | A-6        |
| 28                      | Neba Village, Nagano Pref.            | 27335             | A-6        |
|                         |                                       | 27337             | A-6        |
| 29                      | Shinjo City, Aichi Pref.              | 45913             | A-6        |
| 30                      | Okazaki City, Aichi Pref.             | 45910             | A-6        |
| 31                      | Ise City, Mie Pref.                   | 42829             | A-6        |
| 33                      | Ibigawa Town, Gifu Pref.              | 27388             | A-1a       |
| 34                      | Takashima City, Shiga Pref.           | 43925             | A-1a       |
|                         |                                       | 43924             | A-1b       |

**Table 4-1.** Continued.

|    |                                        |              |      |
|----|----------------------------------------|--------------|------|
| 35 | Taga Town, Shiga Pref.                 | 43512        | B-2a |
| 36 | Matsuzaka City, Mie Pref.              | 41484        | B-2a |
| 37 | Joyo City, Kyoto Pref.                 | 41554        | B-2a |
| 38 | Odai Town, Mie Pref.                   | 40190        | B-2a |
|    |                                        | 45047        | B-2a |
| 39 | Gobo City, Wakayama Pref.              | 41229        | B-2a |
| 40 | Kyoto City, Kyoto Pref.                | 42342        | A-1b |
|    |                                        | 44828        | A-1b |
|    |                                        | 42319        | B-2a |
| 41 | Nantan City, Kyoto Pref.               | 41408        | A-1b |
|    |                                        | 41405        | B-2a |
|    |                                        | 41430        | B-2a |
| 42 | Sasayama City, Hyogo Pref.             | 10307        | A-1b |
| 43 | Kobe City, Hyogo Pref.                 | 45392        | A-1b |
| 44 | Taka Town, Hyogo Pref.                 | 10330        | B-2a |
| 45 | Kyotango City, Kyoto Pref.             | 14171        | A-1b |
| 46 | Toyooka City, Hyogo Pref.              | 42711        | A-1b |
|    |                                        | 42714        | B-2a |
| 47 | Wakasa Town, Tottori Pref.             | 34743        | A-1b |
| 49 | Mimasaka City, Okayama Pref.           | 27659        | B-2a |
| 52 | Misasa Town, Tottori Pref.             | 24574        | B-2b |
| 53 | Kagamino Town, Okayama Pref.           | 29739        | B-2b |
| 54 | Shobara City, Hiroshima Pref.          | 36040        | B-2b |
| 55 | Izumo City, Shimane Pref.              | 18877        | B-2b |
| 57 | Higashihiroshima City, Hiroshima Pref. | 30262        | B-2b |
| 58 | Hatsukaichi City, Hiroshima Pref.      | unnumbered   | B-2b |
|    |                                        | 43167        | B-2b |
| 60 | Shimonoseki City, Yamaguchi Pref.      | 34516        | B-2b |
| 61 | Minamiawaji City, Hyogo Pref.          | 43885        | A-7  |
| 62 | Manno Town, Kagawa Pref.               | TMP_T2882    | A-7  |
| 63 | Miyoshi City, Tokushima Pref.          | TMP_T3498    | A-7  |
| 64 | Toyo Town, Kochi Pref.                 | 29464        | A-7  |
| 65 | Saijo City, Ehime Pref.                | 27679        | A-7  |
|    |                                        | 43078        | A-7  |
| 66 | Saiyo City, Ehime Pref.                | T2241        | A-7  |
| 67 | Kitakyushu City, Fukuoka Pref.         | 28612        | A-9a |
| 68 | Beppu City, Oita Pref.                 | 43637        | A-9a |
| 69 | Yatsushiro City, Kumamoto Pref.        | 27562        | A-9a |
| 70 | Amakusa City, Kumamoto Pref.           | 30342        | A-9a |
| 71 | Kanoya City, Kagoshima Pref.           | 27295        | A-9a |
| 72 | Sasebo City, Nagasaki Pref.            | 27140        | A-9a |
| 73 | Goto City, Nagasaki Pref.              | 45359        | A-9a |
|    |                                        | 45362        | A-9a |
| 74 | Nobeoka City, Miyazaki Pref.           | 27121        | A-9b |
| 75 | Nishimera Village, Miyazaki Pref.      | 26088        | A-9b |
| 76 | Miyakonojo City, Miyazaki Pref.        | 30907        | A-9b |
| 77 | Kimotsuki City, Kagoshima Pref.        | 43397        | A-9b |
| 78 | Kinko Town, Kagoshima Pref.            | 27678        | A-9b |
| 79 | Goto City, Nagasaki Pref.              | 31539        | A-9c |
| 79 | Shinkamigoto City, Nagasaki Pref.      | 45149        | A-9c |
|    |                                        | TMP_110216-1 | A-9c |
| 80 | Goto City, Nagasaki Pref.              | 44316        | A-9c |

---

**Table 4-1.** Continued.

---

|                                     |            |      |
|-------------------------------------|------------|------|
|                                     | 44317      | A-9c |
|                                     | 45355      | A-9c |
| <i>R. t. okiensis</i>               |            |      |
| 50 Okinoshima Town, Shimane Pref.   | 10818      | B-1  |
|                                     | 22341      | B-1  |
| 51 Nishinoshima Town, Shimane Pref. | 43647      | B-1  |
| <i>R. t. yakushimensis</i>          |            |      |
| 81 Yakushima Town, Kagoshima Pref.  | 10182      | A-8  |
|                                     | 45177      | A-8  |
|                                     | 45182      | A-8  |
| <i>R. sakuraii</i>                  |            |      |
| 11 Kanuma City, Tochigi Pref.       | 43633      | A-2  |
|                                     | 43634      | A-2  |
|                                     | 43635      | A-2  |
| 15 Akiruno City, Tokyo Pref.        | 42450      | A-2  |
|                                     | 43740      | A-2  |
| 17 Minobu Town, Yamanashi Pref.     | 45620      | A-2  |
| 20 Shizuoka City, Shizuoka Pref.    | unnumbered | A-2  |
|                                     | 44254      | A-3  |
|                                     | 44286      | A-3  |
| 21 Shizuoka City, Shizuoka Pref.    | 44256      | A-2  |
| 22 Matsumoto City, Nagano Pref.     | 22887      | A-2  |
| 24 Kurobe City, Toyama Pref.        | 45105      | A-3  |
| 24 Kurobe City, Toyama Pref.        | 45106      | A-3  |
| 32 Katsuyama City, Fukui Pref.      | 43591      | A-3  |
| 38 Odai Town, Mie Pref.             | 27647      | A-3  |
|                                     | 40309      | A-3  |
|                                     | 45049      | A-3  |
| 41 Nantan City, Kyoto Pref.         | 41412      | A-3  |
|                                     | unnumbered | A-3  |
| 48 Wakasa Town, Tottori Pref.       | 34740      | A-3  |
| 59 Iwakuni City, Yamaguchi Pref.    | 43893      | A-3  |
| <i>R. tsushimensis</i>              |            |      |
| Tsushima City, Nagasaki Pref.       | 10606      |      |
| <i>R. kobai</i>                     |            |      |
| Amami City, Kagoshima Pref.         | 10051      |      |
| <i>R. ulma</i>                      |            |      |
| Higashi Village, Okinawa Pref.      | 10056      |      |
| <i>R. sauteri</i>                   |            |      |
| Chiayi Country, Taiwan              | 6894       |      |

---

**Table 4-2.** Primers used to amplify mt- and n-DNA in this study.

| Target    | Name        | Sequence                      | Reference              |
|-----------|-------------|-------------------------------|------------------------|
| 16S rRNA  | L1507       | TACACACCGCCCGTCAACCTCTT       | Shimada et al (2011)   |
|           | H1923       | AAGTAGCTCGCTTAGTTTCGG         | Shimada et al (2011)   |
|           | L1879       | CGTACCTTTTGCATCATGGTC         | Shimada et al (2011)   |
|           | H2315       | TTCTTGTTACTAGTTCTAGCAT        | Shimada et al (2011)   |
|           | L2188       | AAAGTGGGCCTAAAAGCAGCCA        | Matsui et al (2006)    |
|           | Wilkinson_6 | CCCTCGTGATGCCGTTGATAC         | Wilkinson et al (2002) |
|           | 16L1        | CTGACCGTGCAAAGGTAGCGTAATCACT  | Hedges (1994)          |
|           | 16H1        | CTCCGGTCTGAACTCAGATCACGTAGG   | Hedges (1994)          |
|           | ND1         | L3032                         | CGACCTCGATGTTGGATCAGG  |
| ND1_Htago |             | GRGRTATTTGGAGTTTGARGCTCA      | Eto et al (2012)       |
| ND1_Ltago |             | GACCTAAACCTCAGYATYCTATTTAT    | Eto et al (2012)       |
| tMet_H    |             | AGGAAGTACAAAGGGTTTTGATC       | Shimada et al (2011)   |
| NCX1      | NCX1F       | ACAACAGTRAGRATATGGAA          | Shimada et al. (2011)  |
|           | NCX1R1      | GCCATATCTCTCCTCGCTTCTTC       | Eto et al (2013)       |
| NFIA      | NFIA-005_F  | TTTGTCA CATCAGGTGTTTT         | This study             |
|           | NFIA-005_R  | CTTGCCTTGGCTGCT               | This study             |
| POMC      | POMC1       | GAATGTATYAAAGMMTGCAAGATGGWCCT | Wiens et al. (2005)    |
|           | POMC7       | TGGCATTTTTGAAAAGAGTCAT        | Smith et al. (2005)    |
| SLC8A3    | SCF_2F      | CAAACACAGRGSAAATTATGAT        | Shimada et al (2011)   |
|           | SCF_2R      | ATAATYCCA ACTGARA ACTC        | Shimada et al (2011)   |
| TYR       | Tyr_L1      | CCCCAGTGGGYRCCCAR TTCCC       | Kuraishi et al (2013)  |
|           | Tyr_H1      | CCACCTTCTGGATTTCCC GTTC       | Kuraishi et al (2013)  |



**Table 4-3.** Summary statistics of each locus. Tajima's D values; length of sequence after alignment; variable sites (*vs*); numbers of haplotypes (*h*); haplotype diversity (*Hd*); and nucleotide diversity ( $\pi$ ).

|                          | Tajima's D |           |          |           | whole (n = 128) |           |          |           | mt-lineage A-1a (n = 18) |           |          |           | mt-lineage A-1b (n = 9) |           |          |           | mt-lineage A-2Rt (n = 12) |           |          |           |       |
|--------------------------|------------|-----------|----------|-----------|-----------------|-----------|----------|-----------|--------------------------|-----------|----------|-----------|-------------------------|-----------|----------|-----------|---------------------------|-----------|----------|-----------|-------|
|                          | sites      | <i>vs</i> | <i>h</i> | <i>Hd</i> | $\pi$           | <i>vs</i> | <i>h</i> | <i>Hd</i> | $\pi$                    | <i>vs</i> | <i>h</i> | <i>Hd</i> | $\pi$                   | <i>vs</i> | <i>h</i> | <i>Hd</i> | $\pi$                     | <i>vs</i> | <i>h</i> | <i>Hd</i> | $\pi$ |
| 16S                      | 1612       | 285       | 115      | 0.998     | 0.024           | 44        | 15       | 0.980     | 0.006                    | 50        | 9        | 1.000     | 0.010                   | 51        | 20       | 0.970     | 0.010                     |           |          |           |       |
| NDI                      | 967        | 287       | 104      | 0.997     | 0.047           | 44        | 14       | 0.974     | 0.010                    | 70        | 9        | 1.000     | 0.026                   | 53        | 10       | 0.970     | 0.016                     |           |          |           |       |
| NCX1(ALC8A1)             | 505        | 26        | 37       | 0.851     | 0.006           | 7         | 5        | 0.651     | 0.003                    | 3         | 4        | 0.525     | 0.002                   | 5         | 4        | 0.649     | 0.003                     |           |          |           |       |
| NFIA                     | 414        | 18        | 21       | 0.735     | 0.003           | 3         | 5        | 0.548     | 0.002                    | 3         | 4        | 0.700     | 0.003                   | 2         | 3        | 0.177     | 0.000                     |           |          |           |       |
| POMC                     | 475        | 40        | 48       | 0.870     | 0.007           | 9         | 6        | 0.712     | 0.004                    | 7         | 6        | 0.775     | 0.004                   | 12        | 10       | 0.859     | 0.006                     |           |          |           |       |
| SLC8A3(NCX3)             | 524        | 21        | 23       | 0.786     | 0.003           | 3         | 4        | 0.236     | 0.001                    | 2         | 3        | 0.242     | 0.000                   | 8         | 6        | 0.659     | 0.002                     |           |          |           |       |
| TYR                      | 318        | 50        | 97       | 0.955     | 0.017           | 17        | 12       | 0.867     | 0.013                    | 15        | 12       | 0.958     | 0.018                   | 20        | 15       | 0.946     | 0.018                     |           |          |           |       |
| mt-lineage A-2Rs (n = 9) |            |           |          |           |                 |           |          |           |                          |           |          |           |                         |           |          |           |                           |           |          |           |       |
| 16S                      |            | 26        | 7        | 0.964     | 0.006           | 43        | 12       | 1.000     | 0.009                    | 7         | 2        | 0.667     | 0.003                   | 41        | 5        | 1.000     | 0.012                     |           |          |           |       |
| NDI                      |            | 38        | 7        | 0.964     | 0.016           | 37        | 8        | 0.939     | 0.013                    | 9         | 2        | 0.667     | 0.006                   | 38        | 4        | 0.900     | 0.018                     |           |          |           |       |
| NCX1(ALC8A1)             |            | 2         | 2        | 0.125     | 0.001           | 2         | 3        | 0.163     | 0.000                    | 3         | 2        | 0.533     | 0.003                   | 3         | 3        | 0.607     | 0.002                     |           |          |           |       |
| NFIA                     |            | 1         | 2        | 0.125     | 0.000           | 2         | 3        | 0.163     | 0.000                    | 2         | 3        | 0.600     | 0.002                   | 1         | 2        | 0.250     | 0.001                     |           |          |           |       |
| POMC                     |            | 6         | 5        | 0.556     | 0.003           | 9         | 5        | 0.652     | 0.004                    | 3         | 2        | 0.533     | 0.003                   | 4         | 3        | 0.607     | 0.003                     |           |          |           |       |
| SLC8A3(NCX3)             |            | 1         | 2        | 0.125     | 0.000           | 2         | 3        | 0.554     | 0.001                    | 1         | 2        | 0.533     | 0.001                   | 1         | 2        | 0.571     | 0.001                     |           |          |           |       |
| TYR                      |            | 11        | 4        | 0.442     | 0.008           | 9         | 5        | 0.493     | 0.007                    | 1         | 2        | 0.533     | 0.002                   | 12        | 7        | 0.964     | 0.018                     |           |          |           |       |
| mt-lineage A-3 (n = 12)  |            |           |          |           |                 |           |          |           |                          |           |          |           |                         |           |          |           |                           |           |          |           |       |
| mt-lineage A-4 (n = 3)   |            |           |          |           |                 |           |          |           |                          |           |          |           |                         |           |          |           |                           |           |          |           |       |
| mt-lineage A-5 (n = 5)   |            |           |          |           |                 |           |          |           |                          |           |          |           |                         |           |          |           |                           |           |          |           |       |
| mt-lineage A-6 (n = 8)   |            |           |          |           |                 |           |          |           |                          |           |          |           |                         |           |          |           |                           |           |          |           |       |
| 16S                      |            | 25        | 8        | 1.000     | 0.005           | 27        | 7        | 1.000     | 0.006                    | 3         | 2        | 0.667     | 0.001                   | 28        | 7        | 0.964     | 0.006                     |           |          |           |       |
| NDI                      |            | 15        | 6        | 0.964     | 0.005           | 32        | 7        | 1.000     | 0.011                    | 3         | 2        | 0.667     | 0.002                   | 21        | 7        | 0.964     | 0.006                     |           |          |           |       |
| NCX1(ALC8A1)             |            | 4         | 5        | 0.505     | 0.002           | 2         | 3        | 0.538     | 0.001                    | 4         | 3        | 0.733     | 0.004                   | 6         | 6        | 0.792     | 0.004                     |           |          |           |       |
| NFIA                     |            | 2         | 3        | 0.425     | 0.001           | 2         | 3        | 0.275     | 0.001                    | 2         | 3        | 0.600     | 0.002                   | 2         | 3        | 0.433     | 0.001                     |           |          |           |       |
| POMC                     |            | 9         | 7        | 0.850     | 0.006           | -         | 1        | -         | -                        | 4         | 3        | 0.600     | 0.003                   | 2         | 3        | 0.242     | 0.001                     |           |          |           |       |
| SLC8A3(NCX3)             |            | 2         | 2        | 0.363     | 0.001           | 2         | 2        | 0.440     | 0.002                    | -         | 1        | -         | -                       | 1         | 2        | 0.264     | 0.001                     |           |          |           |       |
| TYR                      |            | 16        | 13       | 0.975     | 0.016           | 9         | 7        | 0.846     | 0.009                    | 10        | 4        | 0.800     | 0.013                   | 11        | 7        | 0.692     | 0.009                     |           |          |           |       |

**Table 4-3.** Continued.

| sites         | mt-lineage A-9b (n = 5) |   |       |       | mt-lineage A-9c (n = 6) |   |       |       | mt-lineage B-1 (n = 3) |   |       |       | mt-lineage B-2a (n = 12) |    |       |       |
|---------------|-------------------------|---|-------|-------|-------------------------|---|-------|-------|------------------------|---|-------|-------|--------------------------|----|-------|-------|
|               | vs                      | h | Hd    | $\pi$ | vs                      | h | Hd    | $\pi$ | vs                     | h | Hd    | $\pi$ | vs                       | h  | Hd    | $\pi$ |
| I6S           | 44                      | 5 | 1.000 | 0.014 | 41                      | 5 | 0.933 | 0.014 | 4                      | 3 | 1.000 | 0.002 | 36                       | 10 | 0.970 | 0.007 |
| ND1           | 36                      | 5 | 1.000 | 0.018 | 39                      | 4 | 0.800 | 0.023 | -                      | 1 | -     | -     | 42                       | 10 | 0.970 | 0.013 |
| NCX1(ALC8A1)  | 5                       | 5 | 0.822 | 0.003 | 6                       | 7 | 0.879 | 0.003 | -                      | 1 | -     | -     | 2                        | 3  | 0.636 | 0.002 |
| NFIA          | 2                       | 2 | 0.200 | 0.001 | 4                       | 5 | 0.756 | 0.004 | 1                      | 2 | 0.333 | 0.001 | 1                        | 2  | 0.228 | 0.001 |
| POMC          | 6                       | 3 | 0.378 | 0.003 | 7                       | 5 | 0.742 | 0.006 | 8                      | 5 | 0.933 | 0.008 | 9                        | 7  | 0.851 | 0.004 |
| SLC8A3 (NCX3) | 3                       | 4 | 0.644 | 0.001 | -                       | 1 | -     | -     | 3                      | 4 | 0.867 | 0.003 | 4                        | 5  | 0.361 | 0.002 |
| TYR           | 12                      | 9 | 0.978 | 0.013 | 11                      | 6 | 0.848 | 0.014 | 6                      | 5 | 0.933 | 0.009 | 10                       | 9  | 0.812 | 0.010 |

| sites         | mt-lineage B-2b (n = 8) |    |       |       | n-cluster I (n = 68) |    |       |       | n-cluster II (n = 56) |    |       |       |
|---------------|-------------------------|----|-------|-------|----------------------|----|-------|-------|-----------------------|----|-------|-------|
|               | vs                      | h  | Hd    | $\pi$ | vs                   | h  | Hd    | $\pi$ | vs                    | h  | Hd    | $\pi$ |
| I6S           | 24                      | 7  | 0.964 | 0.006 | 204                  | 61 | 0.996 | 0.026 | 176                   | 53 | 0.997 | 0.018 |
| ND1           | 33                      | 7  | 0.964 | 0.014 | 218                  | 57 | 0.994 | 0.049 | 192                   | 47 | 0.994 | 0.037 |
| NCX1(ALC8A1)  | 7                       | 6  | 0.833 | 0.005 | 19                   | 26 | 0.875 | 0.005 | 12                    | 13 | 0.483 | 0.002 |
| NFIA          | 1                       | 2  | 0.125 | 0.000 | 11                   | 16 | 0.493 | 0.002 | 6                     | 8  | 0.486 | 0.001 |
| POMC          | 4                       | 4  | 0.350 | 0.001 | 29                   | 26 | 0.784 | 0.006 | 24                    | 24 | 0.849 | 0.007 |
| SLC8A3 (NCX3) | 3                       | 3  | 0.633 | 0.002 | 9                    | 10 | 0.593 | 0.002 | 12                    | 12 | 0.577 | 0.002 |
| TYR           | 10                      | 13 | 0.967 | 0.010 | 34                   | 58 | 0.935 | 0.014 | 33                    | 43 | 0.907 | 0.016 |

**Table 4-4.** Mean estimated divergence times (MYA) for *R. tagoi*, *R. sakurarii*, and outgroups. Values in parentheses are 95% highest posterior density interval. Bold value indicates calibration point in Calibration I. For node numbers, refer to Fig. 2.

|        | Calibration I           | Calibration II      | Calibration III    |
|--------|-------------------------|---------------------|--------------------|
| Node 1 | 3.04 (4.80–1.59)        | 4.00 (5.96–2.33)    | 4.16 (6.16–2.44)   |
| 2      | 2.01 (3.09–1.05)        | 2.58 (3.82–1.60)    | 2.82 (4.07–1.69)   |
| 3      | 1.81 (2.74–0.90)        | 2.31 (3.38–1.42)    | 2.46 (3.54–1.45)   |
| 4      | 1.40 (2.17–0.72)        | 1.84 (2.69–1.05)    | 1.73 (2.60–0.99)   |
| 5      | 0.88 (1.41–0.40)        | 1.16 (1.87–0.60)    | 1.04 (1.66–0.50)   |
| 6      | 1.04 (1.64–0.53)        | 1.32 (2.00–0.69)    | 1.35 (2.06–0.70)   |
| 7      | 1.57 (2.40–0.78)        | 1.87 (2.78–1.05)    | 2.08 (3.07–1.21)   |
| 8      | 0.82 (1.32–0.39)        | 0.95 (1.60–0.44)    | 1.13 (1.78–0.58)   |
| 9      | 0.85 (1.35–0.38)        | 0.88 (1.40–0.41)    | 1.39 (2.16–0.72)   |
| 10     | 1.59 (2.44–0.80)        | 1.92 (2.85–1.09)    | 2.12 (3.14–1.24)   |
| 11     | 1.41 (2.19–0.72)        | 1.75 (2.59–0.96)    | 1.69 (2.50–0.90)   |
| 12     | 0.35 (0.63–0.12)        | 0.50 (0.95–0.14)    | 0.42 (0.81–0.11)   |
| 13     | 1.06 (1.70–1.02)        | 1.15 (1.85–0.56)    | 1.50 (2.30–0.82)   |
| 14     | 0.33 (0.57–0.14)        | 0.36 (0.64–0.13)    | 0.53 (0.90–0.21)   |
| 15     | 1.83 (2.80–0.91)        | 2.31 (3.36–1.34)    | 2.54 (3.70–1.53)   |
| 16     | 0.64 (1.05–0.27)        | 0.79 (1.30–0.34)    | 0.85 (1.38–0.37)   |
| 17     | 0.12 (0.25–0.02)        | 0.20 (0.43–0.03)    | 0.17 (0.37–0.01)   |
| 18     | 1.39 (2.14–0.69)        | 1.68 (2.53–0.99)    | 1.98 (2.91–1.19)   |
| 19     | 0.43 (0.72–0.18)        | 0.53 (0.90–0.21)    | 0.59 (1.01–0.24)   |
| 20     | 0.95 (1.51–0.44)        | 1.04 (1.67–0.46)    | 1.40 (2.11–0.73)   |
| 21     | 1.18 (1.85–0.57)        | 1.46 (2.22–0.76)    | 1.54 (2.34–0.83)   |
| 22     | 1.85 (2.91–0.90)        | 2.71 (4.34–1.40)    | 2.29 (3.50–1.24)   |
| 23     | 1.03 (1.63–0.51)        | 1.40 (2.15–0.71)    | 1.35 (2.07–0.71)   |
| 24     | 0.62 (1.00–0.28)        | 0.80 (1.28–0.36)    | 0.82 (1.32–0.39)   |
| 25     | 0.75 (1.20–0.33)        | 0.90 (1.46–0.42)    | 1.08 (1.74–0.52)   |
| 26     | 0.10 (0.20–0.01)        | 0.04 (0.13–0.03)    | 0.26 (0.53–0.05)   |
| O-1    | <b>5.02 (6.96–3.11)</b> | 7.99 (12.83–3.56)   | 5.44 (8.46–2.77)   |
| O-2    | 12.04 (19.40–5.69)      | 22.02 (35.97–11.08) | 11.59 (18.29–6.42) |

**Table 4-5.** Demographic parameters estimated by IM analysis.  $N_e$ : effective population size (million individuals);  $m$ : migration rate parameter (migration rate for gene copy/mutation event), of which  $m_{1>2}$  ( $m_{2>1}$ ) indicates the gene flow from group 1 to 2 (2 to 1) forwards in time;  $2N_eM$ : effective population migration rate (number of gene copies/generation);  $T$ : population divergence time (MYA). Values supported by highest probability were shown in HiPt, and HPD95 indicate 95% highest posterior density interval. Parameters with bold and italic characters indicate the values with statistical support and with no significant peak of posterior probability density, respectively.

|                                                                                                                      | $N_1$       | $N_2$       | $N_{\text{ancestor}}$ | $m_{1>2}$    | $m_{2>1}$    | $2N_eM_{1>2}$ | $2N_eM_{2>1}$ | $T$          |
|----------------------------------------------------------------------------------------------------------------------|-------------|-------------|-----------------------|--------------|--------------|---------------|---------------|--------------|
| (1) Cluster I vs. (2) Cluster II                                                                                     |             |             |                       |              |              |               |               |              |
| HiPt                                                                                                                 | 2.18        | 1.73        | 0.40                  | <b>0.16</b>  | <b>0.30</b>  | <b>0.52</b>   | <b>1.23</b>   | 2.72         |
| HPD95                                                                                                                | (1.70–2.87) | (1.34–2.30) | (0.17–0.79)           | (0.07–0.35)  | (0.17–0.53)  | (0.24–1.12)   | (0.70–2.14)   | (2.10–4.29)  |
| (1) <i>R. sakurarii</i> vs. (2) <i>R. tagoi</i> lineage A–2: scheme1                                                 |             |             |                       |              |              |               |               |              |
| HiPt                                                                                                                 | 0.15        | 0.80        | 0.26                  | 0.41         | 0.06         | 0.84          | 0.03          | 0.88         |
| HPD95                                                                                                                | (0.07–0.31) | (0.34–2.06) | (0.03–1.19)           | (0.06–3.01)  | (0.04–2.79)  | (0.10–5.99)   | (0.01–0.74)   | (0.42–3.90)  |
| (1) <i>R. sakurarii</i> vs. (2) <i>R. tagoi</i> lineage A–2: scheme2                                                 |             |             |                       |              |              |               |               |              |
| HiPt                                                                                                                 | 0.16        | 0.86        | -                     | 0.00         | 0.00         | 0.01          | 0.27          | -            |
| HPD95                                                                                                                | (0.05–0.32) | (0.35–2.07) | -                     | (0.00–1.48)  | (0.00–2.28)  | (0.00–2.70)   | (0.06–0.97)   | -            |
| (1) <i>R. sakurarii</i> vs. (2) <i>R. tagoi</i> lineage A–5, 6: scheme 1                                             |             |             |                       |              |              |               |               |              |
| HiPt                                                                                                                 | 0.15        | 0.79        | -                     | 0.56         | 0.91         | 0.95          | 0.44          | -            |
| HPD95                                                                                                                | (0.07–0.31) | (0.38–1.76) | -                     | (0.09–4.19)  | (0.14–4.31)  | (0.18–8.87)   | (0.05–1.05)   | -            |
| (1) <i>R. sakurarii</i> vs. (2) <i>R. tagoi</i> lineage A–5, 6: scheme 2                                             |             |             |                       |              |              |               |               |              |
| HiPt                                                                                                                 | 0.16        | 0.86        | -                     | 0.09         | <b>1.17</b>  | 0.35          | <b>0.95</b>   | -            |
| HPD95                                                                                                                | (0.05–0.32) | (0.41–1.96) | -                     | (0.02–1.40)  | (0.45–2.90)  | (0.11–7.13)   | (0.36–1.93)   | -            |
| (1) <i>R. tagoi</i> lineage A–2 vs. (2) <i>R. tagoi</i> lineage A–5, 6: scheme 1                                     |             |             |                       |              |              |               |               |              |
| HiPt                                                                                                                 | 0.80        | 0.79        | -                     | 0.20         | <b>3.61</b>  | 0.41          | <b>6.68</b>   | -            |
| HPD95                                                                                                                | (0.34–2.06) | (0.38–1.76) | -                     | (0.04–6.53)  | (0.79–10.26) | (0.04–9.78)   | (3.56–21.31)  | -            |
| (1) <i>R. tagoi</i> lineage A–2 vs. (2) <i>R. tagoi</i> lineage A–5, 6: scheme2                                      |             |             |                       |              |              |               |               |              |
| HiPt                                                                                                                 | 0.86        | 0.86        | 0.30                  | 0.16         | <b>4.81</b>  | 0.41          | <b>5.31</b>   | 1.12         |
| HPD95                                                                                                                | (0.35–2.07) | (0.41–1.96) | (0.05–3.60)           | (0.01–12.25) | (3.04–7.52)  | (0.04–3.67)   | (3.68–9.58)   | (0.77–1.67)  |
| (1) ancestor of <i>R. sakurarii</i> and <i>R. tagoi</i> lineage A–2 vs. (2) <i>R. tagoi</i> lineage A–5, 6: scheme 1 |             |             |                       |              |              |               |               |              |
| HiPt                                                                                                                 | 0.26        | 0.79        | 0.43                  | <i>0.41</i>  | <i>0.01</i>  | <i>0.06</i>   | <i>0.04</i>   | 1.80         |
| HPD95                                                                                                                | (0.03–1.19) | (0.38–1.76) | (0.23–0.77)           | (0.00–23.46) | (0.00–14.03) | (0.00–81.15)  | (0.00–34.07)  | (0.96–4.52)  |
| (1) <i>R. sakurarii</i> vs. (2) ancestor of <i>R. tagoi</i> lineage A–2, 5, 6: scheme 2                              |             |             |                       |              |              |               |               |              |
| HiPt                                                                                                                 | 0.16        | 0.30        | 0.26                  | <b>18.05</b> | <b>13.90</b> | <b>10.86</b>  | <b>5.71</b>   | <i>14.70</i> |
| HPD95                                                                                                                | (0.05–0.32) | (0.05–3.60) | (0.04–1.77)           | (6.50–24.64) | (1.76–24.75) | (8.34–64.80)  | (0.82–8.05)   | (7.53–15.03) |

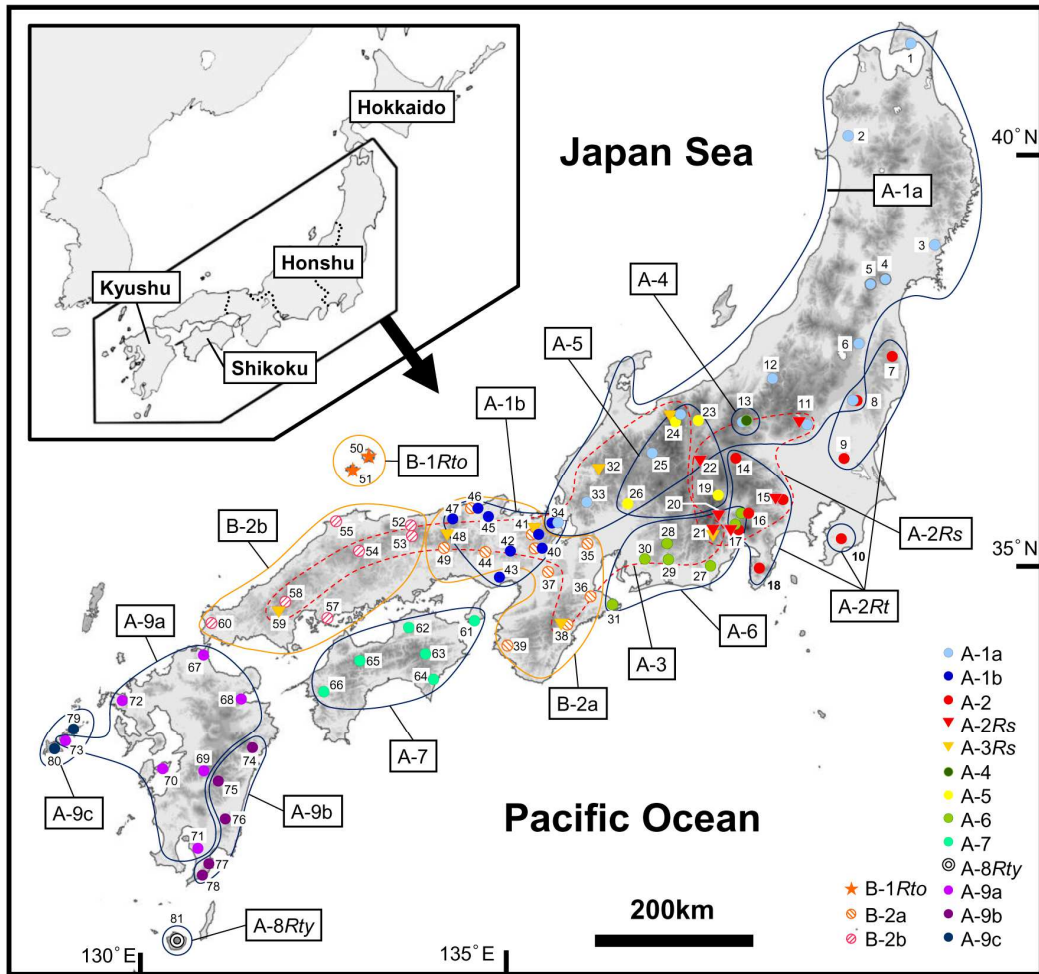

Figure 4-1



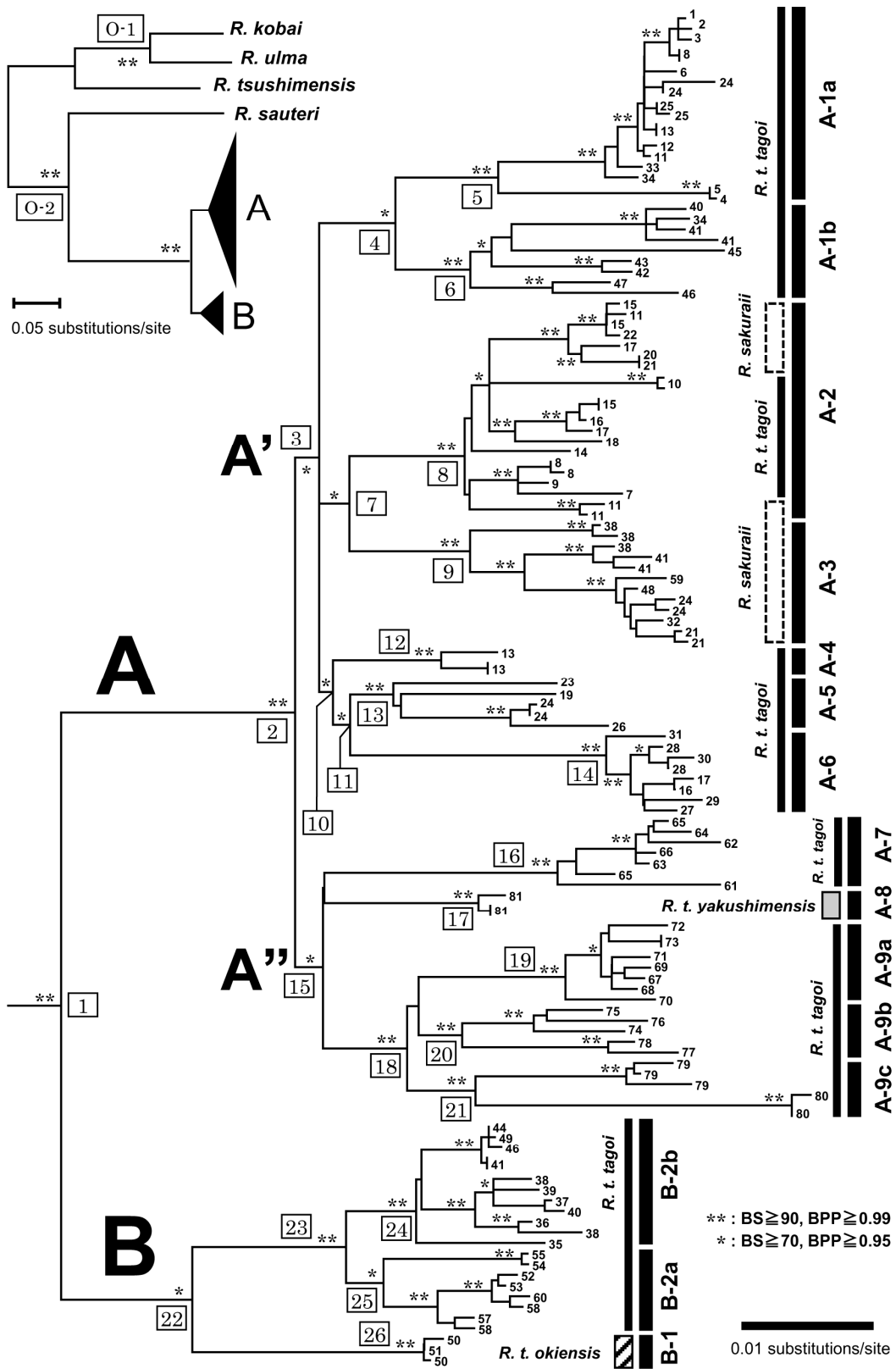

Figure 4-2





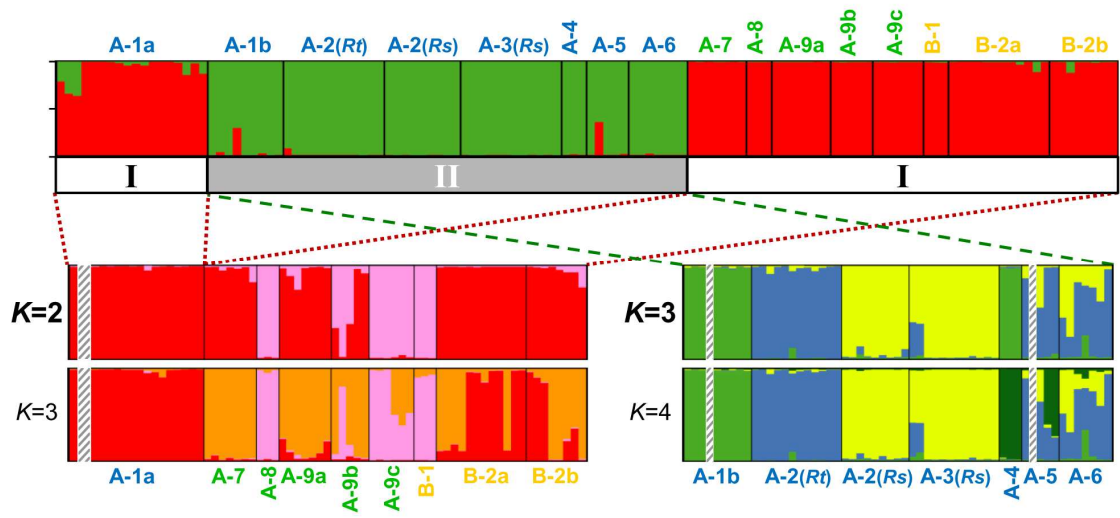
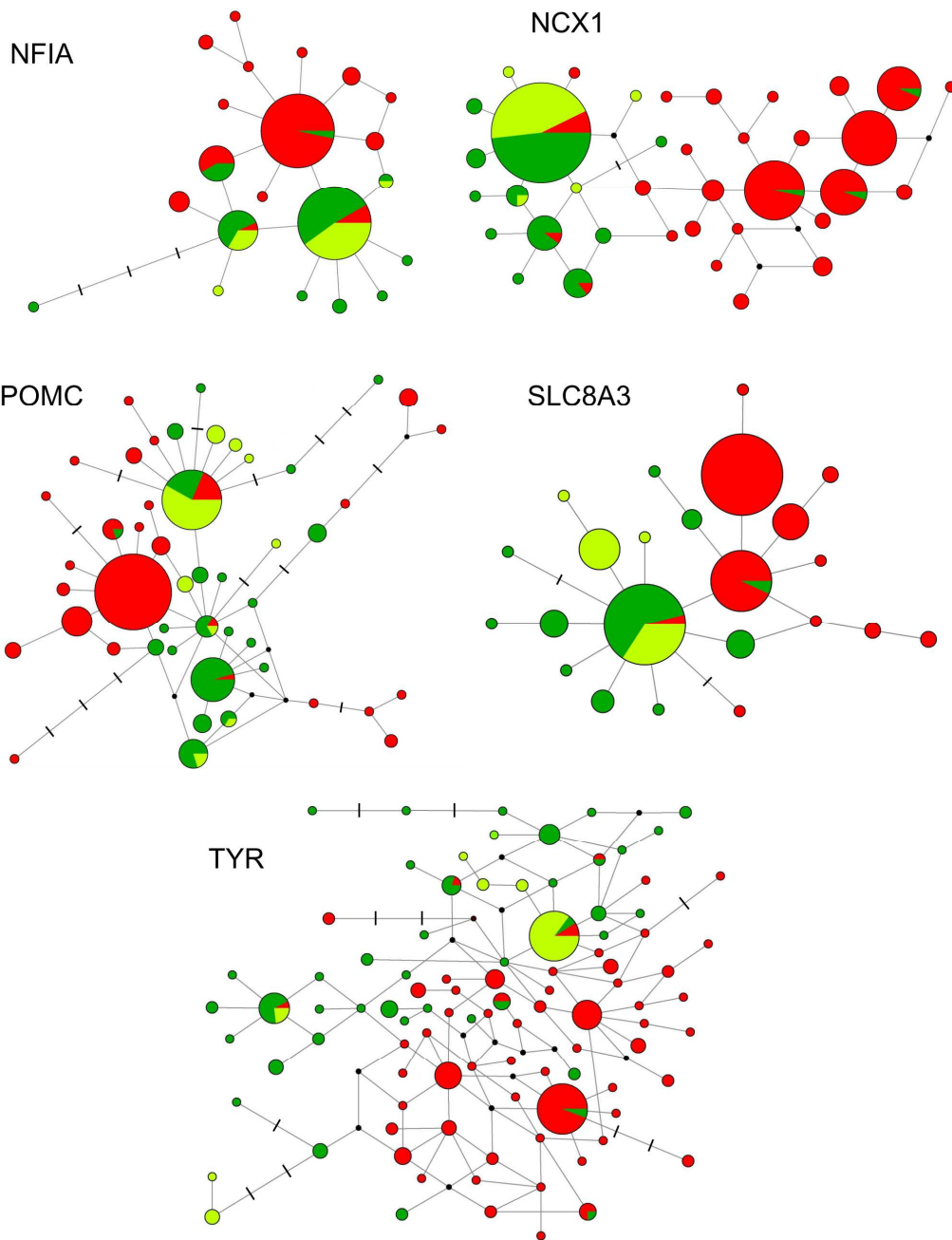

Figure 4-3





**Figure 4-4**



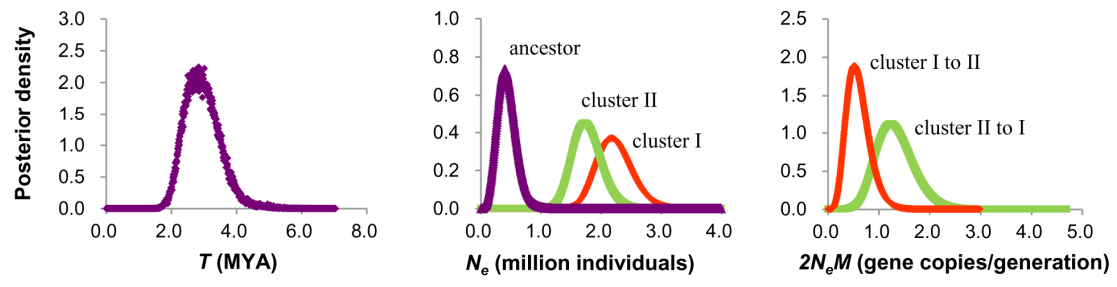

Figure 4-5



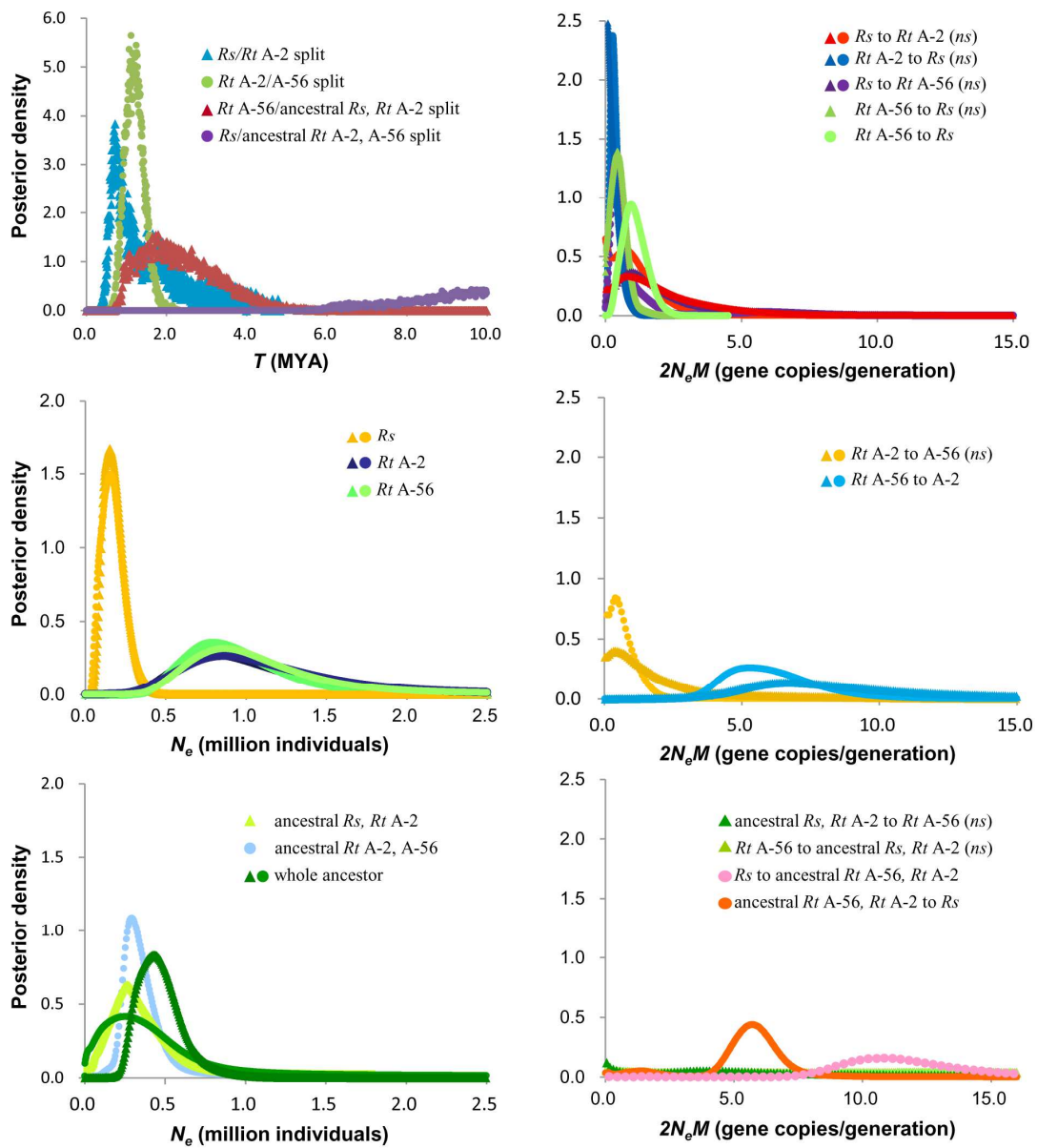
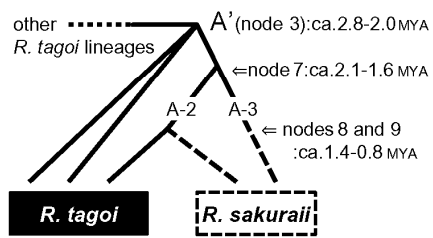

Figure 4-6





### 1: ILS



### 2: introgression

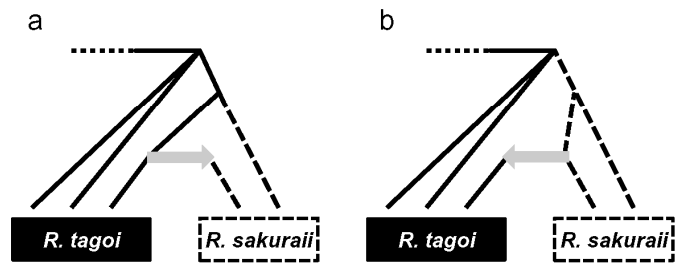

Figure 4-7



## CHAPTER 5

### General Discussion

*Rana tagoi* has been thought to include several cryptic taxa (e.g., *R. tagoi* “large type” and “small type: Sugahara 1990; *R. tagoi* with diploid chromosomes  $2n = 28$ : Ryuzaki *et al.* 2006) in this 20 years. As shown in Chapter 2, phylogenetic analyses using mtDNA revealed that this species contain numerous lineages, and some of them correspond to suspected cryptic taxa. However, the remaining lineages are also distinct genetically, although their morphological/ecological traits have never been sufficiently studied. Furthermore, *R. sakuraii*, a close relative of *R. tagoi*, is phylogenetically totally embedded in *R. tagoi*. *Rana sakuraii* formed two distinct lineages, one of which containing *R. tagoi* samples. Thus neither of the two species are monophyletic on the mtDNA genealogy.

On the other hand, STRUCTURE analysis using nDNA indicates genetic patterns more or less discordant with mtDNA results (Chapters 3 and 4). For example, within the two morphotypes of *R. tagoi* in the Kinki region, the “small type” forms a unique mt-lineage, whereas the “large type” is divided into two lineages, one of which is closer to the “small” lineage than another (Chapters 2, 3). In contrast, analysis based on nDNA shows sharp genetic isolation between the two morphotypes, with the two mt-lineages of the “large type” assigned to a single cluster (Chapter 3). This result suggests heterospecific relationship of the two morphotypes, and conspecificity of the two mt-lineages of the “large type”. The divergence between the “small” and the closest “large” mt-lineage is estimated to occur at ca. 1.8–1.4 MYA, younger than the separation of the “small” and “large” n-clusters around 2.7 MYA (Chapter 4). Considering the faster lineage sorting processes in mtDNA than in nDNA, discordance between the results of mt- and n-DNA analysis of the two morphotypes can be explained by mitochondrial introgression from the “small type” to the “large type” (Chapter 3).

The situation is different between *R. tagoi* and *R. sakuraii*. In STRUCTURE analysis using nDNA, *R. sakuraii* forms a unique nuclear cluster, supporting its distinct specific status. However, the separation between *R. sakuraii* and the closest *R. tagoi* lineage/cluster is

estimated to be not old, only 0.9 MYA, by IM analysis (Chapter 4). This age is much younger than the divergence time between *R. sakuraii* mt-lineages (A-2 and A-3) and all the others (ca. 2.5–1.8 MYA), and is still younger than the separation of two mt-lineages of *R. sakuraii* (ca. 2.1–1.6 MYA). Thus cytonuclear discordance and genealogical paraphyly of *R. sakuraii* would have been induced by recent speciation of this species, which led incomplete lineage sorting (ILS) of mtDNA (Chapter 4).

As discussed above, the *R. tagoi* species complex (including *R. sakuraii*) is a recently diversified group and its evolutionary history seems to be complicated. Thus in the taxonomic study of this complex, especially in describing cryptic taxa, standards often used recently at the specific level taxonomy of animals (e.g., genealogical monophyly and the threshold value of sequence divergence) are not necessarily applicable. Rather, traditional methods, such as comparison of morphological/ecological traits and assessment of reproductive isolation, are more important in classifying the *R. tagoi* species complex.

Evolutionary history of the *R. tagoi* species complex provides a good example in the study of speciation and diversification in amphibians. Resultant phylogenetic relationships and historical demography indicate speciation and diversification of the complex to have occurred recently. The most distinctive trait of the complex is subterranean breeding (for secondary adaptation to open stream in *R. sakuraii*, see below), which is quite unique among brown frogs (genus *Rana*). Only the members of the *R. tagoi* species complex use this environment as the breeding site among anurans from the mainland of Japan. Thus, specialization to this unique niche would have led radiation of this complex, which is now very abundant throughout the three main islands of Japan.

However, degree of dependence on subterranean environment is variable within the complex. For example, Sugahara (1990) reported that *R. tagoi* “small type” breeds in very small subterranean streams or water springs, whereas the “large type” lays eggs besides streams. In this case, different body size is thought to be an adaptation to each microhabitat. Such a tendency of microhabitat segregation is observed in several regions of Honshu where two or more lineages/clusters occur sympatrically (Eto, unpublished data). Furthermore, *R. sakuraii* has adapted secondarily to true stream environment (Chapters 2 and 4; Maeda & Matsui 1999) and does not use subterranean waters. Based on such a variation in the degree of

dependence on subterranean environment among the complex, two different hypotheses about their diversification can be proposed: (1) Some costs (e.g., hybrid infertility) for hybridization among genetic groups induced morphological/ecological character displacement to avoid reproductive interference when multiple groups met in the same place (i.e., reinforcement of reproductive isolation and sympatric speciation) and (2) Variation of reliance on subterranean environment independently arose to adapt various climate/environment of different place induced allopatric speciation of each genetic group. These hypotheses should be tested in future, but at least some taxa seem to have arisen sympatrically, supporting the first hypothesis (Chapter 4).

The results of present study also provide some suggestions on conservation of the *R. tagoi* complex. Now *R. t. tagoi* (sensu lato) is considered as a common, widespread subspecies, and is not included in the Japanese Red List (Ministry of Environment of Japan 2012). However, as discussed in the present and previous studies (e.g., Sugahara 1990; Ryuzaki *et al.* 2006), this species complex surely includes several cryptic taxa. Some of them are actually widespread (e.g., *R. t. tagoi* sensu stricto [mt-Lineage A-1a] and *R. sakuraii* [A-2 and A-3]), but each of candidate cryptic taxa is all restricted to a narrow area of distribution (see Fig. 2-1 in Chapter 2). For example, the distributional range of *R. t. tagoi* “small type” is restricted to the northern Kinki region, although it was once reported from the Kii Peninsula (Sugahara & Matsui 1996). Geographically most limited lineage is *R. t. tagoi* A-4, which is found on only one mountain in the former Kuni Village, Gunma Prefecture, as far as I know. Two subspecies of *R. tagoi* from islands peripheral to the mainland (*R. t. yakushimensis* and *R. t. okiensis*) are categorized as Near Threatened (NT) in the Japanese Red List because their distributional ranges are narrow and environmental conditions of their habitats are becoming worse (Ministry of Environment of Japan 2012). The present study revealed that *R. t. tagoi* from the Goto Islands (mt-Lineage A-9c), whose distributional and environmental situation is considered to be similar to that of two island subspecies, is also differentiated genetically from lineages of other regions. Because *R. t. tagoi* from the Goto Islands has a unique acoustical traits (Matsuo *et al.* 2011), it could be also distinct taxon. Considering rapid degradation of montane environment, where this complex inhabits, immediate reevaluation of conservational status of these candidate cryptic taxa is required.



## SUMMARY

In order to clarify the taxonomic relationships and the evolutionary history of two Japanese brown frogs *Rana tagoi* and *R. sakuraii*, I conducted molecular phylogenetic and population genetic studies. In the phylogenetic tree based on mitochondrial (mt-) DNA, two major clades (A and B) were recognized. Clade A contained both of two species, whereas Clade B consisted of only *R. tagoi* samples. Moreover, within these clades *R. tagoi* was divided into more than 10 lineages, and *R. sakuraii* also divided into two. Because one of the two lineages of *R. sakuraii* also included some *R. tagoi* samples, neither of two species were monophyletic. Some of *R. tagoi* lineages corresponded to known subspecies and morphological/ecological variations, but the remaining ones were also distinctive genetically. These facts indicate that the diversity of *R. tagoi* is greater than previously recognized. Then I focused on the two morphotypes (“large” and “small”) of *R. tagoi* from the Kinki region, and performed detailed genetic survey using mt- and nuclear (n-) DNA. The results obtained in nDNA analysis largely corresponded to the morphological information, although mt-genealogy was more or less discordant with them. These results indicate that *R. tagoi* “large” and the “small” is reproductively isolated (i.e., heterospecific), although introgressive hybridization has occurred in the past. Considering the relationship with topotypic samples, the “large” is true *R. tagoi*, whereas the “small” should be unnamed. Finally, I expanded multilocus analysis to the entire samples. In the nDNA analysis, two major clusters (I and II) were recognized in two species, and the division of clusters was partially correlated to mt-genealogy. *Rana sakuraii* formed a specific subcluster within Cluster II, in agreement with its distinct specific status. The estimated divergence time between *R. sakuraii* and the closest *R. tagoi* population was not old, ca. 0.9 MYA. Thus the paraphyly of *R. sakuraii* on mt-genealogy is thought to be induced by the recent speciation and incomplete lineage sorting of mtDNA. On the other hand, *R. tagoi* was divided into multiple subclusters in nDNA analysis as same as mtDNA ones. The gene flow between subclusters seemed to be limited, so each of them could be different taxa. Present results suggest that genealogical monophyly is not definitive in the classification of *R. tagoi* species complex, and detailed comparison of ecological/morphological traits would be more important.

## 要旨

日本に分布するタゴガエル（タゴ）とその近縁種ナガレタゴガエル（ナガレ）について、種間・種内の遺伝的変異を調査し、その分類学的関係と進化史について考察した。MtDNAに基づく系統解析では全体として2つのクレードA・Bが認められ、そのうちAは両種を、Bはタゴのみを含んだ。さらにそれらの内部で、タゴは10以上、ナガレは2つの系統に細分された。このナガレ2系統のうち、片方はタゴをも内包することから、両種はいずれも単系統群でない。またタゴ系統のうち、少なくとも一部は既知の亜種や、形態・生態型と対応したが、それらと同程度に分化した系統が多く見られ、本種の多様性は従来知られていた以上に高いことが示された。タゴに見られる変異系統のうち、近畿地方産の大小二型について核DNAも併せて解析したところ、mtDNAの系統樹が形態的変異と必ずしも対応しない一方で、核DNAを用いた解析の結果は形態的区分とよく一致した。これは大小間に生殖隔離が存在することを示し、基準産地との関係も踏まえると大型が真のタゴで、小型は未記載種と考えられる。またmtDNA解析の結果が形態的（大小）区分と一致しないのは、過去に大小間で浸透性交雑が起こったためと考えられる。さらに、タゴ・ナガレ全体について複数遺伝子を用いた解析を行ったところ、核DNAの解析では大きく2つのクラスターI・IIが認められ、その区分は部分的にmtDNAの系統と一致した。ナガレはこのうちIIの内部で固有のサブクラスターを成すことから、これを独立種とするのは妥当であろう。また同じく核DNAの解析により、ナガレが最近縁のタゴ集団と分かれたのは約90万年前と、比較的新しいことが示された。従って、ナガレがmtDNAの系統樹上で単系統にならないのは、種分化からの歴史が浅く、系列選別が不完全なためと考えられる。一方、タゴは核DNAの解析でも複数のサブクラスターに分けられた。それらの間の遺伝的交流は限定的であり、それぞれ独立種である可能性が高い。これらタゴ複合群の種分類においては、単系統性のみを重視せず、詳細な生態的・形態的比較を行う必要がある。



## ACKNOWLEDGEMENTS

I wish to express my cordial gratitude to my supervisor, Professor Dr. M. Matsui, for his considerable encouragement, suggestions, and direction throughout this study.

I also thank my colleagues in Professor Matsui's laboratory, Dr. K. Nishikawa, for precious advices and help in the field survey, Dr. N. Yoshikawa, Dr. N. Kuraishi, Dr. T. Matsuki, Dr. A. Hamidy, Mr. G. Aoki, Mr. Y. Hattori, Mr. Y. Mizuno, Mr. T. Nishimura, and Mr. Y. Kawahara for their help in the laboratory and field works. I fully acknowledge many cooperators who helped me in field survey and/or collecting specimens, Dr. K. Araya, Mr. H. Fujita, Dr. M. Hayashi, Dr. T. Hikida, Mr. N. Hotta, Mr. S. Ichihara, Mr. S. Ikeda, Ms. Y. Imada, Mr. K. Kasugai, Dr. M. Kato, Mr. Y. Kawahara, Mr. K. Kawauchi, Dr. J. B. Kim, Mr. N. Koike, Mr. Y. Kokuryo, Mr. K. Komizo, Mr. M. Kumagai, Mr. N. Maeda, Mr. Mm. Matsui, Mr. Mt. Matsui, Mr. T. Matsuo, Dr. Y. Misawa, Mr. Y. Miyagata, Dr. A. Mori, Mr. S. Mori, Mr. H. Moriguchi, Mr. N. Nakahama, Dr. T. Nakano, Mr. Y. Nakase, Mr. M. Oda, Mr. T. Ogue, Mr. S. Okada, Mr. H. Okawa, Mr. J. Oki, Dr. M. Sakamoto, Mr. T. Sasaoka, Mr. Y. Sasaoka, Mr. T. Seto, Dr. T. Shimada, Mr. Z. Shimizu, Mr. R. Shimoyama, Dr. T. Sota, Mr. T. Sueyoshi, Mr. T. Sugahara, Mr. T. Sugihara, Dr. H. Takeuchi, Mr. S. Tanabe, Mr. Y. Tatewaki, Mr. H. Tokunaga, Ms. N. Tokuyama, Dr. A. Tominaga, the late Ms T. Utsunomiya, Mr. M. Yamagami, Dr. A. Yamane, Ms. Y. Yamane, Mr. Y. Yamazaki, and Ms. M. Yumoto. Finally, I would like to extend my indebtedness to my parents for their understanding and support throughout my study.



## REFERENCES

- Avice JC (2000) *Phylogeography: the history and formation of species*. Harvard University Press, Cambridge.
- Ballard JWO, Whitlock MC (2004) The incomplete natural history of mitochondria. *Molecular Ecology*, **13**, 729–744.
- Bandelt H, Forster P, Röhl A (1999) Median-joining networks for inferring intraspecific phylogenies. *Molecular Biology and Evolution*, **16**, 37–48.
- Boulenger G (1920) A monograph of the South Asian, Papuan, Melanesian, and Australian frogs of the genus *Rana*. *Records of the Indian Museum*, **20**, 1–126.
- Castresana J (2000) Selection of conserved blocks from multiple alignments for their use in phylogenetic analysis. *Molecular Biology and Evolution*, **17**, 540–552.
- Chinzei K, Machida H (2001) Formation history of structural landforms and tectonic landforms in Japan. In: *Regional Geomorphology of the Japanese Islands, Introduction to Japanese Geomorphology*, vol. 1. (eds Yonekura N, Kaizuka S, Nogami M, Chinzei K), pp. 298–311. University of Tokyo Press, Tokyo.
- Clement M, Posada D, Crandall KA (2000) TCS: a computer program to estimate gene genealogies. *Molecular Ecology*, **53**, 781–792.
- Conlon JM, Coquet L, Jouenne T *et al.* (2010) Evidence from the primary structures of dermal antimicrobial peptides that *Rana tagoi okiensis* and *Rana tagoi tagoi* (Ranidae) are not conspecific subspecies. *Toxicon*, **55**, 430–435.
- Coyne JA, Orr HA (2004) *Speciation*. Sinauer Associates, Sunderland, MA.
- Daito Y (1999) Development of postmating isolation in the Tago's brown frog group. III. Offspring between Oki population, Tago's brown frog of Oki island ♀ and Stream brown frog ♂. *Amphibian History*, **2**, 23–29.
- Daito Y, Yokota T, Inoue K, Nakata T (1998a) Development of postmating isolation in the Tago's brown frogs (*Rana*) I. Offspring between *Rana sakuraii* and *Rana tagoi tagoi*, Kurama population. *Bulletin of the Faculty of Human Development Kobe University*, **5**, 507–522.

- Daito Y, Hiramoto M, Yoshimoto Y (1998b) Development of postmating isolation in the Tago's brown frogs (*Rana*) II. Offspring between *Rana tagoi tagoi* and Oki population, Tago's brown frog of Oki Isl. *Bulletin of the Faculty of Human Development Kobe University*, **5**, 523–530.
- Dubois A (1992) Notes sur la classification des Ranidae (Amphibiens anoures). *Bulletin Mensuel de la Société Linnéenne de Lyon*, **61**, 305–352.
- Drummond AJ, Suchard MA, Xie D, Rambaut A (2012) Bayesian phylogenetics with BEAUti and the BEAST 1.7. *Molecular Biology and Evolution*, **29**, 1969–1973.
- Edgar R (2004) MUSCLE: multiple sequence alignment with high accuracy and high throughput. *Nucleic Acids Research*, **32**, 1792–1797.
- Evanno G, Regnaut S, Goudet J (2005) Detecting the number of clusters of individuals using the software STRUCTURE: a simulation study. *Molecular Ecology*, **14**, 2611–2620.
- Felsenstein J (1985) Confidence limits on phylogenies: an approach using the bootstrap. *Evolution*, **39**, 783–791.
- Fouquet A, Gilles A, Vences M *et al.* (2007) Underestimation of species richness in neotropical frogs revealed by mtDNA analyses. *PloS ONE*, **2**, e1109.
- Fouquet A, Green DM, Waldman B *et al.* (2009) Phylogeography of *Leiopelma hochstetteri* reveals strong genetic structure and suggests new conservation priorities. *Conservation Genetics*, **11**, 907–919.
- Frost DR (1985) *Amphibian Species of the World: A Taxonomic and Geographical Reference*. Allen Press, Lawrence.
- Frost DR, Grant T, Faivovich J *et al.* (2006) The amphibian tree of life. *Bulletin of the American Museum of Natural History*, **297**, 1–370.
- Funk DJ, Omland KE (2003) Species-level paralogy and polyphyly: frequency, causes, and consequences, with insights from animal mitochondrial DNA. *Annual Review of Ecology, Evolution, and Systematics*, **34**, 397–423.
- Garrick RC, Sunnucks P, Dyer RJ (2010) Nuclear gene phylogeography using PHASE: dealing with unresolved genotypes, lost alleles, and systematic bias in parameter estimation. *BMC Evolutionary Biology*, **10**, 118.

- Hamidy A, Matsui M, Shimada T *et al.* (2011) Morphological and genetic discordance in two species of Bornean *Leptobrachium* (Amphibia, Anura, Megophryidae). *Molecular Phylogenetics and Evolution*, **61**, 904–13.
- Hedges SB (1994) Molecular evidence for the origin of birds. *Proceedings of the National Academy of Sciences of the United States of America*, **91**, 2621–2624.
- Hey J (2010) Isolation with migration models for more than two populations. *Molecular Biology and Evolution*, **27**, 905–920.
- Hey J, Nielsen R (2004) Multilocus methods for estimating population sizes, migration rates and divergence time, with applications to the divergence of *Drosophila pseudoobscura* and *D. persimilis*. *Genetics*, **167**, 747–760.
- Hey J, Nielsen R (2007) Integration within the Felsenstein equation for improved Markov chain Monte Carlo methods in population genetics. *Proceedings of the National Academy of Sciences of the United States of America*, **104**, 2785–2790.
- Hillis DM, Mable BK, Larson A, Davis SK, Zimmer EA (1996) Nucleic acids IV: sequencing and cloning. In: *Molecular Systematics* (eds Hillis DM, Mable BK, Moritz C), pp. 321–378. Sinauer Associates, Sunderland.
- Hillis DM, Wilcox TP (2005) Phylogeny of the New World true frogs (*Rana*). *Molecular Phylogenetics and Evolution*, **34**, 299–314.
- Huelsenbeck JP, Hillis DM (1993) Success of phylogenetic methods in the four–taxon case. *Systematic Biology*, **42**, 247–264.
- Hurt C, Silliman K, Anker A, Knowlton N (2013) Ecological speciation in anemone-associated snapping shrimps (*Alpheus armatus* species complex). *Molecular Ecology*, **22**, 4532–4548.
- Igawa T, Kurabayashi A, Nishioka M, Sumida M (2006) Molecular phylogenetic relationship of toads distributed in the Far East and Europe inferred from the nucleotide sequences of mitochondrial DNA genes. *Molecular Phylogenetics and Evolution*, **38**, 250–260.
- Iijima A, Tada R (1990) Evolution of tertiary sedimentary basins of Japan in reference to opening of the Japan Sea. *Journal of the Faculty of Science, University of Tokyo, Section II*, **22**, 121–171.

- Jacobsen F, Omland KE (2012) Extensive introgressive hybridization within the northern oriole group (Genus *Icterus*) revealed by three-species isolation with migration analysis. *Ecology and Evolution*, **2**, 2413–2429.
- Jobb G (2008) TREEFINDER version October 2008. Available from [www.treefinder.de](http://www.treefinder.de).
- Jobb G (2011) TREEFINDER version March 2011. Available from [www.treefinder.de](http://www.treefinder.de).
- Kuramoto M, Satou N, Oumi S, Kurabayashi A, Sumida M (2011) Inter- and intra-island divergence in *Odorrana ishikawae* (Anura, Ranidae) of the Ryukyu Archipelago of Japan, with description of a new species. *Zootaxa*, **2767**, 25–40.
- Kusano T, Fukuyama K, Miyashita N (1995a) Age determination of the stream frog, *Rana sakuraii*, by skeletochronology. *Journal of Herpetology*, **29**, 625–628.
- Kusano T, Fukuyama K, Miyashita N (1995b) Body size and age determination brown frog *Rana tagoi tagoi* by skeletochronology in southwestern of the Kanto. *Japanese Journal of Herpetology*, **16**, 29–34.
- Lawson LP (2010) The discordance of diversification: evolution in the tropical-montane frogs of the Eastern Arc Mountains of Tanzania. *Molecular Ecology*, **19**, 4046–60.
- Leaché AD, Reeder TW (2002) Molecular systematics of the eastern fence lizard (*Sceloporus undulatus*): a comparison of parsimony, likelihood, and Bayesian approaches. *Systematic Biology*, **51**, 44–68.
- Liu K, Wang F, Chen W *et al.* (2010) Rampant historical mitochondrial genome introgression between two species of green pond frogs, *Pelophylax nigromaculatus* and *P. plancyi*. *BMC Evolutionary Biology*, **10**, 201.
- Macey JR, Schulte J a, Larson A *et al.* (1998) Phylogenetic relationships of toads in the *Bufo bufo* species group from the eastern escarpment of the Tibetan Plateau: a case of vicariance and dispersal. *Molecular Phylogenetics and Evolution*, **9**, 80–87.
- Maeda N, Matsui M (1999) *Frogs and Toads of Japan*, Revised Edition. Bun-ichi Sogo Shuppan, Tokyo.
- Matsui M (1984) Morphometric variation analyses and revision of the Japanese toads (genus *Bufo*, Bufonidae). *Contributions from the Biological Laboratory, Kyoto University*, **26**, 209–428.

- Matsui M (1987) Isozyme variation in salamanders of the *nebulosus-lichenatus* complex of the genus *Hynobius* from eastern Honshu, Japan, with a description of a new species. *Japanese Journal of Herpetology*, **12**, 50–64.
- Matsui M (1994) A taxonomic study of the *Rana narina* complex, with description of three new species (Amphibia: Ranidae). *Zoological Journal of the Linnean Society*, **111**, 385–415.
- Matsui M (2000) Batrachology of Japan and adjacent regions — a systematic review. *Comparative Biochemistry and Physiology Part B*, **126**, 247–256.
- Matsui M (2011) On the brown frogs from the Ryukyu Archipelago, Japan, with descriptions of two new species (Amphibia, Anura). *Current Herpetology*, **30**, 111–128.
- Matsui M, Miyazaki K (1984) *Hynobius takedai* (Amphibia, Urodela), a new species of salamander from Japan. *Zoological Science*, **1**, 665–671.
- Matsui M, Sato T, Tanabe S, Hayashi T (1992) Electrophoretic analyses of systematic relationships and status of two Hynobiid salamanders from Hokkaido (Amphibia: Caudata). *Herpetologica*, **48**, 408–416.
- Matsui M, Shimada T, Ota H, Tanaka-Ueno T (2005) Multiple invasions of the Ryukyu Archipelago by Oriental frogs of the subgenus *Odorrana* with phylogenetic reassessment of the related subgenera of the genus *Rana*. *Molecular Phylogenetics and Evolution*, **37**, 733–742.
- Matsui M, Nishikawa K, Utsunomiya T, Tanabe S (2006a) Geographic allozyme variation in the Japanese clouded salamander, *Hynobius nebulosus* (Amphibia: Urodela). *Biological Journal of the Linnean Society*, **89**, 311–330.
- Matsui M, Shimada T, Liu W-Z *et al.* (2006b) Phylogenetic relationships of Oriental torrent frogs in the genus *Amolops* and its allies (Amphibia, Anura, Ranidae). *Molecular Phylogenetics and Evolution*, **38**, 659–666.
- Matsui T, Matsui M (1990) A new brown frog (genus *Rana*) from Honshu, Japan. *Herpetologica*, **46**, 78–85.
- Matsuo T, Sakamoto M, Nakano K *et al.* (2011) Calls of *Rana tagoi* from local populations in Kyushu (I). *Proceedings of the Kyushu Herpetological Society*, **2**, 6-16.
- Mayr E, Linsley EG, Usinger RL (1953) Methods and principles of systematic zoology. McGraw-Hill, New York.

- Ministry of Environment of Japan (2012) The Revised Red List and Red Data Book. Available from [http://www.biodic.go.jp/rdb/rdb\\_f.html](http://www.biodic.go.jp/rdb/rdb_f.html).
- Mitsui Y, Setoguchi H (2012) Demographic histories of adaptively diverged riparian and non-riparian species of *Ainsliaea* (Asteraceae) inferred from coalescent analyses using multiple. *BMC Evolutionary Biology*, **12**, 254.
- Mueller RL (2006) Evolutionary rates, divergence dates, and the performance of mitochondrial genes in Bayesian phylogenetic analysis *Systematic Biology*, **55**, 289-300.
- Nakamura K, Ueno S-I (1963) *Japanese Reptiles and Amphibians in Colour*. Hoikusha, Osaka.
- Nielsen R, Wakeley J (2001) Distinguishing migration from isolation: a Markov chain Monte Carlo approach. *Genetics*, **158**, 885–896.
- Nishikawa K, Matsui M, Tanabe S, Sato S (2007) Morphological and allozymic variation in *Hynobius boulengeri* and *H. stejnegeri* (Amphibia: Urodela: Hynobiidae). *Zoological Science*, **24**, 752–766.
- Nishioka M, Sumida M, Ohta S, Suzuki H (1987a) Speciation of Tree Allied Genera, *Buergeria*, *Rhacophorus* and *Polypedates*, Elucidated by the Method of Electrophoretic Analyses. *Scientific Report of the Laboratory for Amphibian Biology, Hiroshima University*, **9**, 53–96.
- Nishioka M, Ohta S, Sumida M (1987b) Intraspecific Differentiation of *Rana tagoi* Elucidated by Electrophoretic Analyses of Enzymes and Blood Proteins. *Scientific Report of the Laboratory for Amphibian Biology, Hiroshima University*, **9**, 97–133.
- Nishioka M, Sumida M, Ueda H, Wu Z (1990) Genetic relationships among 13 *Bufo* species and subspecies elucidated by the method of electrophoretic analyses. *Scientific Report of the Laboratory for Amphibian Biology, Hiroshima University*, **10**, 53–91.
- Nishizawa T, Kurabayashi A, Kunihara T *et al.* (2011) Mitochondrial DNA diversification, molecular phylogeny, and biogeography of the primitive rhacophorid genus *Buergeria* in East Asia. *Molecular Phylogenetics and Evolution*, **59**, 139–147.
- Nöllert A, Nöllert C (1992) *Die Amphibien Europas: Bestimmung, Gefährdung, Schutz*. Franckh-Kosmos, Stuttgart.
- Okada Y (1928) Notes on Japanese frogs. *Annotationes Zoologicae Japonenses*, **11**, 269–277.
- Okada Y (1930) *A monograph of the Japanese tailless Batrachians*. Iwanami-shoten, Tokyo.



- Peakall R, Smouse PE (2006) GENALEX 6: genetic analysis in Excel. Population genetic software for teaching and research. *Molecular Ecology Notes*, **6**, 288–295.
- Pritchard J, Stephens M, Donnelly P (2000) Inference of population structure using multilocus genotype data. *Genetics*, **155**, 945–959.
- Rambaut A, Drummond A (2009) Tracer version 1.5, Available from <http://beast.bio.ed.ac.uk/Tracer>.
- Reilly SB, Marks SB, Jennings WB (2012) Defining evolutionary boundaries across parapatric ecomorphs of Black Salamanders (*Aneides flavipunctatus*) with conservation implications. *Molecular Ecology*, **21**, 5745–61.
- Roelants K, Gower DJ, Wilkinson M *et al.* (2007) Global patterns of diversification in the history of modern amphibians. *Proceedings of the National Academy of Sciences of the United States of America*, **104**, 887–892.
- Ronquist F, Huelsenbeck JP (2003) MrBayes 3: Bayesian phylogenetic inference under mixed models. *Bioinformatics*, **19**, 1572–1574.
- Rovito SM (2010) Lineage divergence and speciation in the web-toed salamanders (Plethodontidae: *Hydromantes*) of the Sierra Nevada, California. *Molecular Ecology*, **19**, 4554–4571.
- Rozas J, Sanchez-DelBarrio JC, Messeguer X, Rozas R (2003) DnaSP, DNA polymorphism analyses by the coalescent and other methods. *Bioinformatics*, **19**, 2496–2497.
- Ryuzaki M, Nishioka M, Kawamura T (2006) Karyotypes of *Rana tagoi* Okada with diploid number 28 in the Chausu Mountains of the Minamishinshu district of Nagano Prefecture, Japan (Anura: Ranidae). *Cytogenetic and Genome Research*, **114**, 56–65.
- Sekiya K, Miura I, Ogata M (2012) A new frog species of the genus *Rugosa* from Sado Island, Japan (Anura, Ranidae). *Zootaxa*, **3575**, 49–62.
- Sekiya K, Ohtani H, Ogata M, Miura I (2010) Phyletic diversity in the frog *Rana rugosa* (Anura: Ranidae) with special reference to a unique morphotype found from Sado Island, Japan. *Current Herpetology*, **29**, 69–78.
- Shibata Y (1988) The type localities of three subspecies of a Japanese brown frog, *Rana tagoi* OKADA (Amphibia: Ranidae). *Bulletin of the Osaka Museum of Natural History*, **43**, 43–46.

- Shimada T, Matsui M, Yambun P *et al.* (2008) Detection of two cryptic taxa in *Meristogenys amoropalamus* (Amphibia, Ranidae) through nuclear and mitochondrial DNA analyses. *Zootaxa*, **1843**, 24–34.
- Shimada T, Matsui M, Yambun P, Sudin A (2011) A taxonomic study of Whitehead's torrent frog, *Meristogenys whiteheadi*, with descriptions of two new species (Amphibia: Ranidae). *Zoological Journal of the Linnean Society*, **161**, 157–183.
- Stejneger L (1907) Herpetology of Japan and adjacent territory. *Bulletin of the United States National Museum*, **58**, 1–577.
- Stephens M, Smith N, Donnelly P (2001) A new statistical method for haplotype reconstruction from population data. *The American Journal of Human Genetics*, **68**, 978–989.
- Sugahara T (1990) Reproductive ecology of *Rana tagoi tagoi* at Kitayama in Kyoto. *Japanese Journal of Herpetology*, **13**, 145.
- Sugahara T, Matsui M (1992) Larval growth and development in two types of the Japanese brown frog, *Rana tagoi tagoi*, at Kumogahata, Kyoto. *Japanese Journal of Herpetology*, **14**, 209.
- Sugahara T, Matsui M (1993) Morphometric comparisons in two types of *Rana t. tagoi* from Kumogahata, Kyoto. *Japanese Journal of Herpetology*, **15**, 83.
- Sugahara T, Matsui M (1994) An investigation of characters that discriminate two morphotypes of *Rana tagoi tagoi*. *Japanese Journal of Herpetology*, **15**, 151.
- Sugahara T, Matsui M (1995) Acoustic comparisons in two types of *Rana t. tagoi* from Kumogahata, Kyoto. *Japanese Journal of Herpetology*, **16**, 64–65.
- Sugahara T, Matsui M (1996) Morphological variation in *Rana tagoi* from regions around Kinki. *Japanese Journal of Herpetology*, **16**, 151–152.
- Sugahara T, Matsui M (1997) Breeding seasons and sites in two types of *Rana tagoi tagoi* from Kumogahata, Kyoto. *Japanese Journal of Herpetology*, **17**, 68–69.
- Sumida M, Ogata M (1998) Intraspecific differentiation in the Japanese brown frog *Rana japonica* Inferred from Mitochondrial DNA Sequences of the Cytochrome b Gene. *Zoological Science*, **15**, 989–1000.
- Swofford DL (2002) PAUP\*. Phylogenetic Analysis Using Parsimony (\*and Other Methods), Version 4. Sinauer Associates, Sunderland.

- Tajima F (1989) Statistical method for testing the neutral mutation hypothesis by DNA polymorphism. *Genetics*, **123**, 585–595.
- Tanabe AS (2008) Phylogears version 1.5.2010.03.24. Software distributed by the author at <http://www.fifthdimension.jp/>.
- Tanabe AS (2011) Kakusan4 and Aminosan: two programs for comparing nonpartitioned, proportional and separate models for combined molecular phylogenetic analyses of multilocus sequence data. *Molecular Ecology Resources*, **11**, 914–921.
- Tanaka T, Matsui M, Takenaka O (1994) Estimation of phylogenetic relationships among Japanese brown frogs from mitochondrial cytochrome b gene (Amphibia: Anura). *Zoological Science*, **11**, 753–757.
- Tanaka T, Matsui M, Takenaka O (1996) Phylogenetic relationships of Japanese brown frogs (*Rana*: Ranidae) assessed by mitochondrial cytochrome b gene sequences. *Biochemical Systematics and Ecology*, **24**, 299–307.
- Tanaka-Ueno T, Matsui M, Chen S-L, Takenaka O, Ota H (1998) Phylogenetic relationships of brown frogs from Taiwan and Japan assessed by mitochondrial cytochrome b gene sequences (*Rana*: Ranidae). *Zoological science*, **15**, 283–288.
- Tavaré S (1986) Some probabilistic and statistical problems in the analysis of DNA sequences. *Lectures on Mathematics in the Life Sciences*, **17**, 57–86.
- Temminck CJ, Schlegel H (1838) Reptilia. In: *Fauna Japonica auctore PF de Siebold*, pp. xxi, 97–144, 8 plates.
- Thompson JD, Higgins DG, Gibson TJ (1994) CLUSTAL W: improvement the sensitivity of progressive multiple sequence alignment through sequence weighting, position-specific gap penalties and weight matrix choice. *Nucleic Acids Research*, **22**, 4673–4680.
- Tominaga A, Matsui M (2008) Taxonomic status of a salamander species allied to *Hynobius naevius* and a reevaluation of *Hynobius naevius yatsui* (Amphibia, Caudata). *Zoological Science*, **25**, 107–114.
- Tominaga A, Matsui M, Yoshikawa N *et al.* (2013) Phylogeny and historical demography of *Cynops pyrrhogaster* (Amphibia: Urodela): Taxonomic relationships and distributional changes associated with climatic oscillations. *Molecular Phylogenetics and Evolution*, **66**, 654–667.

- Vences M, Thomas M, Bonett RM, Vieites DR (2005) Deciphering amphibian diversity through DNA barcoding: chances and challenges. *Philosophical transactions of the Royal Society of London. Series B, Biological Sciences*, **360**, 1859–1868.
- Vredenburg VT, Bingham R, Knapp R *et al.* (2007) Concordant molecular and phenotypic data delineate new taxonomy and conservation priorities for the endangered mountain yellow-legged frog. *Journal of Zoology*, **271**, 361–374.
- Waples R, Gaggiotti O (2006) What is a population? An empirical evaluation of some genetic methods for identifying the number of gene pools and their degree of connectivity. *Molecular Ecology*, **15**, 1419–1439.
- Wiens J, Fetzner JW Jr, Parkinson CL, Reeder TW (2005) Hylid frog phylogeny and sampling strategies for species clades. *Systematic Biology*, **54**, 719–748.
- Wilkinson JA, Drewes RC, Tatum OL (2002) A molecular phylogenetic analysis of the family Rhacophoridae with an emphasis on the Asian and African genera. *Molecular Phylogenetics and Evolution*, **24**, 265–273.
- Woerner AE, Cox MP, Hammer MF (2007) Recombination-filtered genomic datasets by information maximization. *Bioinformatics*, **23**, 1851–1853.
- Wright S (1931) Evolution in Mendelian populations. *Genetics*, **16**, 97–159.
- Yoshikawa N, Matsui M, Nishikawa K, Kim J-B, Kryukov A (2008) Phylogenetic relationships and biogeography of the Japanese clawed salamander, *Onychodactylus japonicus* (Amphibia: Caudata: Hynobiidae), and its congener inferred from the mitochondrial cytochrome b gene. *Molecular Phylogenetics and Evolution*, **49**, 249–259.
- Yoshikawa N, Matsui M, Nishikawa K, Misawa Y, Tanabe S (2010) Allozymic variation in the Japanese clawed salamander, *Onychodactylus japonicus* (Amphibia: Caudata: Hynobiidae), with special reference to the presence of two sympatric genetic types. *Zoological Science*, **27**, 33–40.
- Yoshikawa N, Matsui M (2013) A new salamander of the genus *Onychodactylus* from Tsukuba Mountains, eastern Honshu, Japan (Amphibia, Caudata, Hynobiidae). *Current Herpetology*, **32**, 9–25.

## **APPENDIX**

# Taxonomic Relationships among Turkish Water Frogs as Revealed by Phylogenetic Analyses Using mtDNA Gene Sequences

Ufuk Bülbül<sup>1</sup>, Masafumi Matsui<sup>2\*</sup>, Bilal Kutrup<sup>1</sup> and Koshiro Eto<sup>2</sup>

<sup>1</sup>Department of Biology, Faculty of Sciences, Karadeniz Technical University, Trabzon 61080, Turkey

<sup>2</sup>Graduate School of Human and Environmental Studies, Kyoto University, Yoshida Nihonmatsu-cho, Sakyo-ku, Kyoto 606-8501, Japan

We assessed taxonomic relationships among Turkish water frogs through estimation of phylogenetic relationships among 62 adult specimens from 44 distinct populations inhabiting seven main geographical regions of Turkey using 2897 bp sequences of the mitochondrial Cytb, 12S rRNA and 16S rRNA genes with equally-weighted parsimony, likelihood, and Bayesian methods of inference. Monophyletic clade (Clade A) of the northwesternmost (Thrace) samples is identified as *Pelophylax ridibundus*. The other clade (Clade B) consisted of two monophyletic subclades. One of these contains specimens from southernmost populations that are regarded as an unnamed species. The other subclade consists of two lineages, of which one corresponds to *P. caralitanus* and another to *P. bedriagae*. Taxonomic relationships of these two species are discussed and recognition of *P. caralitanus* as a subspecies of *P. bedriagae* is proposed.

**Key words:** mitochondrial DNA, *Pelophylax ridibundus*, *Pelophylax bedriagae caralitanus*, *Pelophylax bedriagae*, taxonomy

## INTRODUCTION

Turkish water frogs have long been treated as a single species: *Rana ridibunda* (Pallas, 1771) (e.g., Bodenheimer, 1944; Başoğlu and Özeti, 1973). The species, originally described from Gurjev (now Atyrau), Kazakhstan (Dubois and Ohler, 1996 “1994”), occurs very widely from Central Europe, northwards to the Baltic Sea and southwards to the Mediterranean regions, eastwards to Asiatic Russia, and southwards to the Middle East (Frost, 2011). However, Bodenheimer (1944) found specimens with an orange-colored venter from Beyşehir Lake in the Central Anatolia region of Turkey, that were later described as a distinct subspecies *R. ridibunda caralitana* by Arıkan (1988). Distribution area of this subspecies was thereafter widened to the Central Anatolia and Mediterranean regions of Turkey (e.g., Atatür et al., 1990; Ayaz et al., 2006). Joermann et al. (1988) and Schneider et al. (1992) called western Turkey water frogs as *R. levantina*, which name was later replaced by *R. bedriagae* (Dubois and Ohler, 1996 “1994”), although identification of Anatolian water frogs as *R. bedriagae* was challenged by Plötner et al. (2001). Schneider and Sinsch (1999) and Sinsch and Schneider (1999) synonymized *R. r. caralitana* with *R. bedriagae*, but Jdeidi et al. (2001) insisted that *R. caralitana* is specifically distinct from *R. bedriagae*.

Based on results of molecular phylogenetic studies,

Frost et al. (2006) proposed to change the generic name of water frogs from *Rana* to *Pelophylax*. In the most recent list of Turkish water frogs, Franzen et al. (2008) recognized only two species, *P. ridibundus* and *P. caralitanus*, and omitted *R. bedriagae*. Quite recently, Akın et al. (2010a) examined relationships between genetic and morphological characteristics among water frogs from Turkish Lake District. In addition, Akın et al. (2010b) studied detailed genetic variations and estimated the history of diversifications among water frogs from eastern Mediterranean regions including Turkey. However, they did not make any definite conclusions about the taxonomy of these frogs.

In order to understand taxonomic relationships among water frogs within Turkey, we studied samples from across the country using mitochondrial DNA sequence variation. For this purpose we adopted both rapidly (Cytb) and slowly (12S rRNA and 16S rRNA) evolving genes, different from Akın et al. (2010b), who studied only rapidly evolving genes (ND2 and ND3). Finally, we made a taxonomic assessment, rather than divergence time estimation, unlike Akın et al. (2010b).

## MATERIALS AND METHODS

### Sampling

We examined DNA sequences of Cytb, 12S rRNA, and 16S rRNA genes from 62 adult specimens of 44 distinct populations inhabiting seven main geographical regions of Turkey (Fig. 1, Table 1). Specimen collection was performed in 2007 and 2008. As outgroups, we used sequences of *Pelophylax* (as *Rana nigromaculatus* and *P. chosenicus* from GenBank (Accession Number: NC002805 and EU386874, respectively).

\* Corresponding author. Phone: +81-75-753-6846;  
Fax : +81-75-753-6846;  
E-mail: fumi@zoo.zool.kyoto-u.ac.jp  
doi:10.2108/zsj.28.930

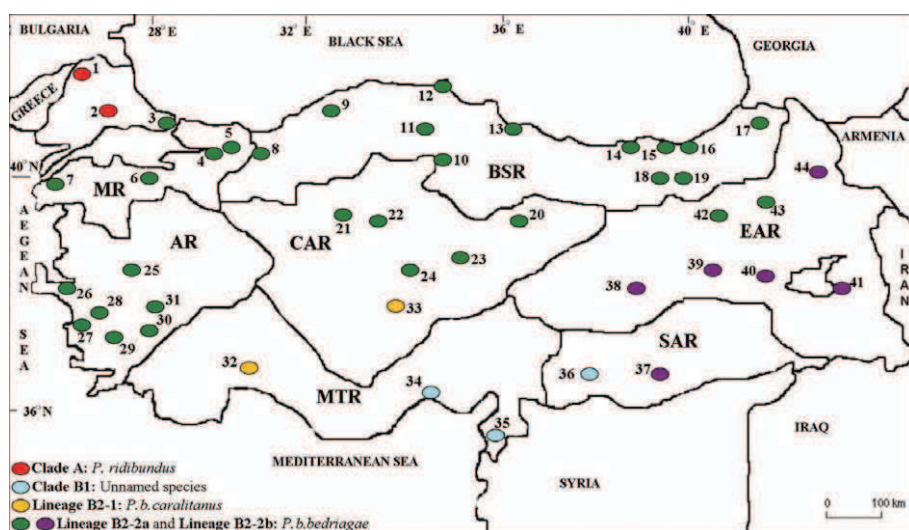

**Fig. 1.** Map showing the localities of the water frog samples from seven main geographic regions of Turkey. MR: Marmara Region, AR: Aegean Region, MTR: Mediterranean Region, CAR: Central Anatolia Region, BSR: Black Sea Region, EAR: Eastern Anatolia Region, SAR: Southeastern Anatolia Region. For sample numbers, refer to Table 1.

### Sequencing

Total DNA was extracted from ethanol-preserved tissues by standard phenol-chloroform extraction (Hillis et al., 1996) or using a commercial kit (Macherey-Nagel, NucleoSpin Tissue Kit, 740952.50) according to the manufacturer's instructions.

A partial sequence of mitochondrial cytochrome b (Cytb), the complete sequences of 12S rRNA, and a partial fragment of 16S rRNA genes were amplified by PCR using the primers listed in Table 2. Cytb amplification involved an initial denaturation step of 7 min at 94°C and 40 cycles of denaturation for 40 s at 94°C, primer annealing for 30 s at 46°C, extension for 60 s at 72°C, and a final 7 min extension at 72°C. The PCR cycle for 12S + 16S rRNA amplification included initial denaturation step of 4 min at 94°C and 33 cycles of denaturation for 30 s at 94°C, primer annealing for 30 s at 53°C, extension for 150 s at 72°C, and a final 7 min extension at 72°C.

Amplified PCR products were purified using polyethylene glycol (PEG) purification procedures; these were used directly as templates for cycle sequencing reactions with fluorescent dye-labeled terminators (ABI Prism Big Dye Terminators v.3.1. cycle sequencing kits). We cycle sequenced the amplified fragments using the primers listed in Table 2. The sequencing reaction products were purified by ethanol precipitation following the manufacturer's protocol and then run on an automated ABI PRISM 3130 genetic analyzer. All samples were sequenced in both directions. The obtained sequences have been deposited in GenBank (AB640897–640996; Table 1).

### Phylogenetic analyses

The nucleotide sequences of each gene were aligned using the ClustalW option in the Bioedit software (Hall, 1999). Haplotypes were determined using DAMBE (Xia and Xie, 2001) program. After confirming the suitability for combination of all of the sequences of the three genes, by performing the partition-homogeneity test (parsimony method by Farris et al. [1995] as implemented in PAUP\*4.0b10 [Swofford, 2000]), we combined the data on these three genes. Phylogenetic analyses based on the combined data were performed by maximum parsimony (MP), maximum likelihood (ML), and Bayesian inference (BI) methods. The MP analysis was implemented in MEGA v. 5.01 software package (Tamura et al., 2011) using a heuristic search with the close-neighbor-interchange

(CNI) branch-swapping algorithm and ten random-addition replicates. Transitions and transversions were equally weighted, and gaps were treated as missing data. The ML and BI analyses, respectively, were performed using TREEFINDER (Jobb, 2008) and MrBayes 3.1.2 (Huelsenbeck and Ronquist, 2001). Best fit nucleotide substitution model based on Akaike's information criteria (AIC) was determined for each gene region with KAKUSAN v. 4 software (Tanabe, 2007). In the BI analysis, the following settings were applied: number of Markov chain Monte Carlo (MCMC) generations = six million; sampling frequency = 100; burn-in = 10,000. The burn-in size was determined by checking convergences of -log likelihood (-lnL) using Tracer v. 1.5 (Rambaut and Drummond, 2007). The robustness of the resultant MP and ML trees were evaluated using non-parametric bootstrap analyses with 1000 and 100 pseudo-replications, respectively, and statistical support of the resultant BI trees was determined based on Bayesian posterior probability (BPP). We a priori regarded tree nodes with bootstrap value (BS) 70% or greater as sufficiently resolved (Huelsenbeck and Hillis, 1993), and those between 50 to 70% as tendencies. In the BI analysis, we considered nodes with a BPP of 95% or greater as significant (Leaché and Reeder, 2002). Uncorrected pairwise sequence divergences for each gene were calculated using MEGA 5.01 v. software package (Tamura et al., 2011).

## RESULTS

### Sequences and statistics

Sequence statistics for the three gene fragments and the combined alignment, when all nucleotide positions were included, are provided in Table 3. For all 62 ingroup individuals (except for one individual from the GaziAntep population, for which we failed in the PCR amplification of Cytb), we determined sequences of 405 bp of the mitochondrial Cytb, 973 bp of the 12S rRNA, and 1519 bp of the 16S rRNA genes. Of 2897 nucleotides generated, 399 were variable and 331 were parsimony informative. DAMBE program disclosed 20 haplotypes from 61 individuals for Cytb, while 35 haplotypes for 12S rRNA, and 45 haplotypes for 16S rRNA were detected from 62 individuals. Within the ingroup (for 61 individuals), alignment of the combined genes revealed a total of 54 unique haplotypes. Haplotypes were identical between samples 8 and 15; between 13 and 9, 10, 21, and 23; between 28-2 and 30-3; and between 26-1 and 31-1) (Fig. 2).

In the ML analysis, the best fit model selected by KAKUSAN v. 4 software (Tanabe, 2007) for 12S rRNA was J2 (Jobb, 2008) with a gamma shape parameter estimated as 0.227 while it was GTR (Tavaré, 1986) for 16S rRNA and TN93 (Tamura and Nei, 1993) for 1st codon position of Cytb with gamma shape parameters estimated as 0.115 and 9.815, respectively. K80 (Kimura, 1980) and F81 (Felsenstein, 1981) models were selected as the best fit models for 2nd and 3rd codon positions of Cytb, respectively. In the BI analysis, best fit model selected by KAKUSAN for 12S rRNA, 16S rRNA and 1st codon position

**Table 1.** Samples used for mtDNA analysis in this study together with the information on voucher and GenBank accession numbers. KTUFS = Faculty of Science, Karadeniz Technical University.

| Sample No. | Locality             | GenBank Accession No. |          |          | Voucher  |
|------------|----------------------|-----------------------|----------|----------|----------|
|            |                      | Cytb                  | 12S rRNA | 16S rRNA |          |
| 1          | Edirne, Büyükdöllük  | AB640977              | AB640897 | AB640932 | KTUFS 1  |
| 2          | Tekirdağ, Malkara    | AB640978              | AB640897 | AB640933 | KTUFS 2  |
| 3          | İstanbul, Şile       | AB640986              | AB640922 | AB640975 | KTUFS 3  |
| 4          | Kocaeli, Şirinköy    | AB640986              | AB640922 | AB640974 | KTUFS 4  |
| 5          | Sakarya, Söğütlü     | AB640986              | AB640924 | AB640973 | KTUFS 5  |
| 6          | Bursa, Nilüfer Brook | AB640986              | AB640925 | AB640976 | KTUFS 6  |
| 7          | Çanakkale, Kepez     | AB640996              | AB640926 | AB640949 | KTUFS 7  |
| 8          | Bolu, Gerede         | AB640986              | AB640923 | AB640969 | KTUFS 8  |
| 9          | Zonguldak, Çaycuma   | AB640986              | AB640922 | AB640969 | KTUFS 9  |
| 10         | Çorum, Kuşsaray      | AB640986              | AB640922 | AB640969 | KTUFS 10 |
| 11         | Kastamonu, Tosya     | AB640986              | AB640922 | AB640971 | KTUFS 11 |
| 12         | Sinop, Erfelek       | AB640986              | AB640922 | AB640970 | KTUFS 12 |
| 13         | Samsun, Bafra        | AB640986              | AB640922 | AB640969 | KTUFS 13 |
| 14         | Giresun, Piraziz     | AB640986              | AB640930 | AB640969 | KTUFS 14 |
| 15         | Trabzon, Beşikdüzü   | AB640986              | AB640923 | AB640969 | KTUFS 15 |
| 16         | Rize, Fındıklı       | AB640986              | AB640929 | AB640969 | KTUFS 16 |
| 17         | Artvin, Şavşat       | AB640995              | AB640911 | AB640948 | KTUFS 17 |
| 18         | Gümüşhane, Şiran     | AB640986              | AB640926 | AB640969 | KTUFS 18 |
| 19         | Bayburt, Suludere    | AB640986              | AB640923 | AB640968 | KTUFS 19 |
| 20         | Sivas, Serpincik     | AB640986              | AB640931 | AB640969 | KTUFS 20 |
| 21         | Ankara, Ayaş         | AB640986              | AB640922 | AB640969 | KTUFS 21 |
| 22         | Kırıkkale, Bahşılı   | AB640986              | AB640920 | AB640972 | KTUFS 22 |
| 23         | Nevşehir, Gülşehir   | AB640986              | AB640922 | AB640969 | KTUFS 23 |
| 24-1       | Konya, Akşehir Lake  | AB640982              | AB640901 | AB640937 | KTUFS 24 |
| 24-2       | Konya, Akşehir Lake  | AB640982              | AB640901 | AB640952 | KTUFS 25 |
| 24-3       | Konya, Akşehir Lake  | AB640983              | AB640901 | AB640938 | KTUFS 26 |
| 25-1       | Manisa, Karaali      | AB640985              | AB640903 | AB640940 | KTUFS 27 |
| 25-2       | Manisa, Karaali      | AB640984              | AB640927 | AB640954 | KTUFS 28 |
| 25-3       | Manisa, Karaali      | AB640986              | AB640928 | AB640954 | KTUFS 29 |
| 25-4       | Manisa, Karaali      | AB640986              | AB640920 | AB640961 | KTUFS 30 |
| 25-5       | Manisa, Karaali      | AB640987              | AB640904 | AB640941 | KTUFS 31 |
| 26-1       | İzmir, Urla          | AB640984              | AB640915 | AB640954 | KTUFS 32 |
| 26-2       | İzmir, Urla          | AB640984              | AB640915 | AB640962 | KTUFS 33 |
| 26-3       | İzmir, Urla          | AB640988              | AB640915 | AB640962 | KTUFS 34 |
| 26-4       | İzmir, Urla          | AB640984              | AB640915 | AB640963 | KTUFS 35 |
| 26-5       | İzmir, Urla          | AB640984              | AB640921 | AB640964 | KTUFS 36 |
| 27         | Aydın, Söke          | AB640984              | AB640918 | AB640958 | KTUFS 37 |
| 28-1       | Aydın, Germencik     | AB640984              | AB640917 | AB640957 | KTUFS 38 |
| 28-2       | Aydın, Germencik     | AB640984              | AB640915 | AB640939 | KTUFS 39 |
| 28-3       | Aydın, Germencik     | AB640984              | AB640915 | AB640959 | KTUFS 40 |
| 28-4       | Aydın, Germencik     | AB640984              | AB640919 | AB640960 | KTUFS 41 |
| 29-1       | Muğla, Fethiyeşalı   | AB640989              | AB640905 | AB640942 | KTUFS 42 |
| 29-2       | Muğla, Fethiyeşalı   | AB640990              | AB640906 | AB640943 | KTUFS 43 |
| 30-1       | Denizli, Kaklık      | AB640984              | AB640902 | AB640939 | KTUFS 44 |
| 30-2       | Denizli, Kaklık      | AB640984              | AB640916 | AB640955 | KTUFS 45 |
| 30-3       | Denizli, Kaklık      | AB640984              | AB640915 | AB640939 | KTUFS 46 |
| 31-1       | Denizli, Acıpayam    | AB640984              | AB640915 | AB640954 | KTUFS 47 |
| 31-2       | Denizli, Acıpayam    | AB640984              | AB640915 | AB640956 | KTUFS 48 |
| 32         | Antalya, Manavgat    | AB640980              | AB640899 | AB640935 | KTUFS 49 |
| 33-1       | Konya, Dineksaray    | AB640981              | AB640900 | AB640936 | KTUFS 50 |
| 33-2       | Konya, Dineksaray    | AB640981              | AB640914 | AB640953 | KTUFS 51 |
| 34         | Mersin, Mezitli      | AB640979              | AB640898 | AB640934 | KTUFS 52 |
| 35         | Hatay, Asi Stream    | AB640979              | AB640912 | AB640950 | KTUFS 53 |
| 36         | Gaziantep, Çaykuyu   | –                     | AB640913 | AB640951 | KTUFS 54 |
| 37         | Şanlıurfa, Bozova    | AB640991              | AB640907 | AB640944 | KTUFS 55 |
| 38         | Malatya, Doğanşehir  | AB640993              | AB640908 | AB640966 | KTUFS 56 |
| 39         | Elazığ, Kovancılar   | AB640993              | AB640908 | AB640965 | KTUFS 57 |
| 40         | Bitlis, Adilceviz    | AB640993              | AB640909 | AB640946 | KTUFS 58 |
| 41         | Van, Edremit         | AB640994              | AB640910 | AB640947 | KTUFS 59 |
| 42         | Erzincan, Tercan     | AB640986              | AB640922 | AB640967 | KTUFS 60 |
| 43         | Erzurum, Pasinler    | AB640986              | AB640926 | AB640967 | KTUFS 61 |
| 44         | Kars, Sarıkamış      | AB640992              | AB640908 | AB640945 | KTUFS 62 |

of Cytb was GTR (Tavaré, 1986) with a gamma shape parameter estimated as 6.636, 4.250, and 1.450, respectively. As the best fit models for the 2nd and 3rd codon positions of Cytb, K80 (Kimura, 1980) and F81 (Felsenstein, 1981) models, respectively, were selected. The likelihood value of the ML tree was  $-lnL = 6336.499$ .

### Phylogenetic relationships

Phylogenetic analyses for the three genes employing three different optimality criteria yielded very slightly different topologies, and only the BI tree is shown in Fig. 2. As shown in the figure, two major clades (Clades A and B) were recovered with strong supports.

The first of these (Clade A) includes northwesternmost (Thrace) samples. Monophyly of the Thrace samples with respect to the other groups was always strongly supported (MP and ML BS = 99 and 100%, respectively; BPP = 100%).

The other clade (Clade B) was also recovered with strong support (MP BS = 97%, ML BS = 96%, BPP = 100%). Clade B consisted of two monophyletic subclades: southernmost subclade (Subclade B1: MP BS = 99%, ML BS = 100%, BPP = 100%) and the other subclade with all the rest of samples (Subclade B2: MP BS = 99%, ML BS = 100%, BPP = 100%).

Subclade B2 consisted of two main lineages: Lineage B2-1, samples from the Central Anatolia and West Mediterranean regions (MP BS = 99%, ML BS = 100%, BPP = 100%), and Lineage B2-2, including all the remaining samples (MP and ML BS both 87%, BPP = 100%). Samples of the Lineage B2-2 were further divided into two sublineages: B2-2b (samples from the Eastern Anatolia region; MP BS = 99%, ML BS = 100%, BPP = 100%) and B2-2a (all the remaining samples; MP BS = 80%, ML BS = 99%, BPP = 100%). Relationships among the samples of B2-2a were unresolved. Uncorrected p-distances among main groups are given in Table 4.

### Ventral color variation among lineages

As shown in Fig. 3, samples of the Lineage B2-1 had the characteristically orangish ventral marking which is unique among all lineages.

## DISCUSSION

In the most recent reviewing work of water frogs in and around Turkey, Akın et al. (2010b) did not show bases for their identification of samples they studied, or



**Table 2.** Primers used to amplify mitochondrial DNA in this study.

| Target | Name   | Sequence 5'-3'               | Reference                                 |
|--------|--------|------------------------------|-------------------------------------------|
| 12S    | ThrLm  | AAARCATKGGTCTTGTAAARCC       | Modified from Shaffer and Mcknight (1996) |
| 12S    | 12SH1  | GACACCGTCAAGTCCTTTGGGTTT     | This study                                |
| 12S    | L1091  | AAACTGGGATTAGATACCCACTAT     | 12SA-L in Palumbi et al. (1991)           |
| 12S    | Hnew   | TACCATGTTACGACTTTCCTCTTCT    | H1548 in Matsui et al. (2005)             |
| 12S    | Lnew   | TACACACCGCCCGTCACCCCTTT      | Shimada et al. (2011)                     |
| 12S    | tval-H | AAGTAGCTCGCTTAGTTTCGG        | Shimada et al. (2011)                     |
| 16S    | tval-L | CGTACCTTTTGCATCATGGTC        | Shimada et al. (2011)                     |
| 16S    | H2317  | TTCTTGTTACTAGTTCATAGCAT      | Shimada et al. (2011)                     |
| 16S    | L2204  | AAAGTGGGCCTAAAAGCAGCCA       | L2188 in Matsui et al. (2006)             |
| 16S    | Wil6   | CCCTCGTGATGCCGTTGATAC        | 6 in Wilkinson et al. (2002)              |
| 16S    | L2606  | CTGACCGTGCAAAGGTAGCGTAATCACT | 16L1 in Hedges (1994)                     |
| 16S    | H3056  | CTCGGTCTGAACTCAGATCAGTAGG    | 16H1 in Hedges (1994)                     |
| Cytb   | L14850 | TCTCATCCTGATGAAACTTTGGCTC    | Tanaka et al. (1994)                      |
| Cytb   | H15502 | GGATTAGCTGGTGTGAAATTGTCTGGG  | Tanaka et al. (1994)                      |

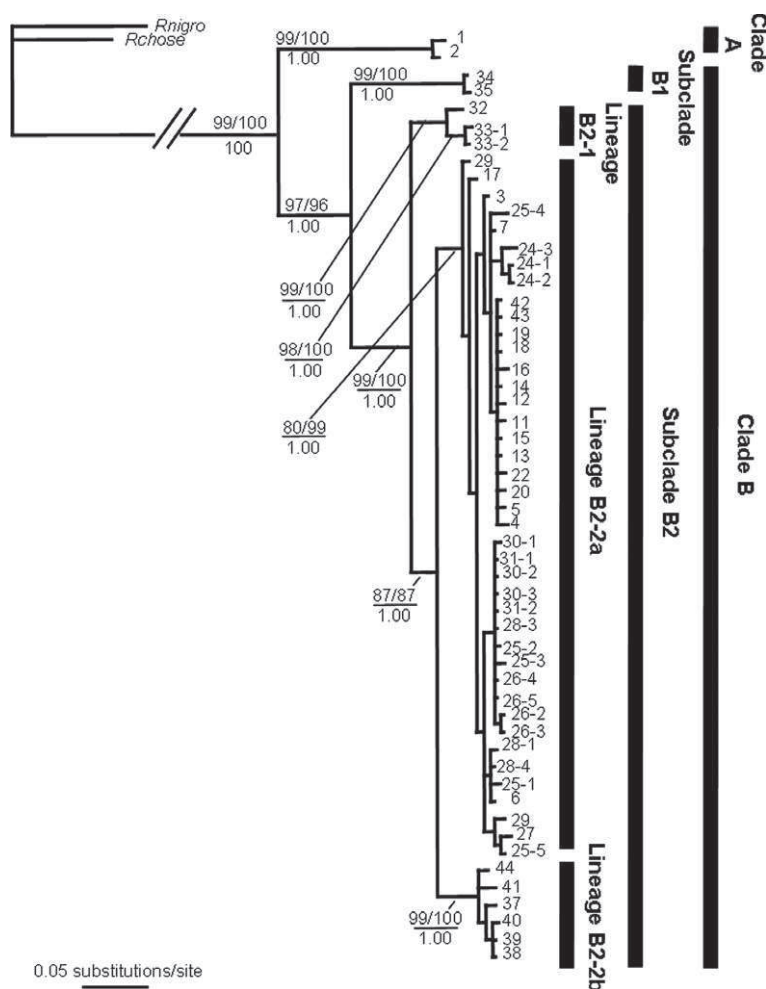
**Fig. 2.** Bayesian tree of a 2897-bp sequence of Cytb, 12S rRNA, and 16S rRNA for Turkish water frogs. Numbers above branches represent bootstrap support for MP (1000 replicates)/ML (100) inference, and numbers below branches indicate Bayesian posterior probabilities. For sample numbers, refer to Fig. 1 and Table 1.

make any definite conclusions about taxonomic status of their haplotype groups. Akin et al. (2010b) used only rapidly evolving genes (Mueller, 2006), and with regard to the Turkish samples, they analyzed 340 bp of ND3 genes in 359

**Table 3.** Alignment statistics for fragments of the Cytb, 12SrRNA, and 16S rRNA (all nucleotide positions included); number of base pairs (bp), number of variable sites (vs), number of parsimony informative sites (pi).

|          | bp   | vs  | pi  |
|----------|------|-----|-----|
| Cytb     | 405  | 106 | 80  |
| 12S rRNA | 973  | 109 | 93  |
| 16S rRNA | 1519 | 184 | 158 |
| Combined | 2897 | 399 | 331 |

individuals and detected 61 haplotypes, and in a longer sequence of 1038 bp of ND2 gene, they found 27 haplotypes in 35 individuals. We used both rapidly and slowly evolving genes and found a slightly smaller amount of divergences (20 haplotypes in Cytb to 45 haplotypes in 16S rRNA) among the Turkish water frogs, probably due to smaller sample size on an average. However, phylogenetic relationships resolved by three different genes we adopted were nearly similar, and resultant combined analysis gave lineages very similar to the haplotype groups reported by Akin et al. (2010b). Thus, our analysis can be regarded as pertinent to discuss taxonomic relationships among the Turkish water frogs.

Our phylogenetic analyses clearly demonstrated the existence of two major monophyletic clades in water frogs from Turkey. One of these (Clade A) includes the northwesternmost (Thrace) samples. From their mt ND2 and ND3 gene sequences data, Akin et al. (2010b) also found frogs from Thrace to constitute a lineage distinct from Anatolian frogs. They identified the frogs from Thrace as *P. ridibundus* because they were very similar to European populations of *P. ridibundus* in sequences. Our analyses using GenBank data also revealed that Clade A forms a monophyletic group with *P. ridibundus* from Greece (DQ474212). Thus, our Clade A should be identified as that species.

Genetic distances observed among different lineages in our samples were not very large, but p-distances in 16S rRNA between Clade A (*P. ridibundus*) and Clade B ( $\leq 3.1\%$ ), are viewed as indicating the level of species difference among the frogs (Fouquet et al., 2007). Thus, the Turkish water frogs in the Clade B are judged to be not conspecific with *P. ridibundus*.

Subclade B1 occupied the most basal position of Clade B while it was judged to be specifically different from Clade A with uncorrected p-distance in 16S rRNA of 3.1%. Although distances among genetic groups in Clade B were not large ( $\leq 2.3\%$ ), distances between Subclade B1 and Subclade B2 (1.9–2.3%) were evidently larger than those between two lineages of Subclade B2 (0.6–1.2%), indicating genetic distinctness of Subclade B1. As discussed below, Subclade B2 itself is considered to contain

two different taxa (Lineage B2-1 [*P. caralitanus*] and Lineage B2-2), and Subclade B1 should better be placed at a higher taxonomic position than these lineages. Unique genetic characteristics of Subclade B1 among Turkish water frogs indicate it to constitute a distinct species for which no

**Table 4.** Comparison of uncorrected p-distances (in %, means followed by ranges in parenthesis) for fragments of the Cytb, 12S rRNA, and 16S rRNA among five genetic groups recognized: Clade A (northwesternmost); Subclade B1 (southernmost); Lineage B2-1 (central Anatolia and western Mediterranean); Lineage B2-2b (eastern Anatolia); Lineage B2-2a (all remaining samples).

|                 | 1             | 2             | 3             | 4             |
|-----------------|---------------|---------------|---------------|---------------|
| Cytb            |               |               |               |               |
| 1 Clade A       | –             |               |               |               |
| 2 Subclade B1   | 5.3 (5.2–5.4) | –             |               |               |
| 3 Lineage B2-1  | 5.2 (4.9–5.4) | 4.0 (4.0–4.2) | –             |               |
| 4 Lineage B2-2a | 5.2 (4.9–5.7) | 3.4 (3.2–3.7) | 2.0 (1.7–2.5) | –             |
| 5 Lineage B2-2b | 5.2 (4.9–5.4) | 3.9 (3.7–4.2) | 2.0 (1.5–2.5) | 1.0 (0.5–1.5) |
| 12S rRNA        |               |               |               |               |
| 1 Clade A       | –             |               |               |               |
| 2 Subclade B1   | 1.9 (1.8–1.9) | –             |               |               |
| 3 Lineage B2-1  | 2.2 (2.2–2.2) | 1.2 (1.0–1.3) | –             |               |
| 4 Lineage B2-2a | 2.1 (1.9–2.4) | 1.2 (1.0–1.5) | 0.6 (0.4–0.9) | –             |
| 5 lineage B2-2b | 2.7 (2.6–2.8) | 1.7 (1.6–1.9) | 1.1 (1.1–1.3) | 0.7 (0.5–0.9) |
| 16S rRNA        |               |               |               |               |
| 1 Clade A       | –             |               |               |               |
| 2 Subclade B1   | 3.1 (3.1–3.1) | –             |               |               |
| 3 Lineage B2-1  | 2.5 (2.4–2.6) | 2.1 (2.0–2.1) | –             |               |
| 4 Lineage B2-2a | 2.8 (2.7–2.9) | 2.1 (2.0–2.3) | 1.0 (0.8–1.2) | –             |
| 5 Lineage B2-2b | 2.8 (2.6–2.8) | 2.1 (1.9–2.1) | 0.8 (0.6–0.9) | 0.8 (0.6–1.0) |

available name is found. Frogs in Subclade B1 occur in the southernmost areas of Turkey, and superficially barely distinguishable from frogs of the lineages in Subclade B2, except for Lineage B2-1 (*P. caralitanus*). Further studies including samples from adjacent regions of southernmost Turkey are required to evaluate its taxonomic validity.

In Subclade B2, Lineages B2-1 and B2-2 may be considered heterospecific, as they occur nearly sympatrically in the Central Anatolia region. Lineage B2-1 is restricted to the Central Anatolia and Western Mediterranean regions, where *Rana ridibunda caralitana* (= *Pelophylax caralitanus*) was described. Our samples in this clade exhibit orange color and characteristic marking on the ventral surface that fit the original description of *P. caralitanus*. Thus, Lineage B2-1 should be identified as that taxon. Heterospecific relationships of lineages in Clade B and *P. ridibundus* (Clade A) are as discussed above, and recognition of *P. caralitanus* as a species conforms to the conclusion of Jdeidi et al. (2001). However, the fact is not so simple as discussed by Akın et al. (2010a: see below).

Based on bioacoustic data, Schneider and Sinsch (1999) considered water frogs from Beyşehir Lake (type locality of *R. r. caralitanus*) and Aegean and Western Mediterranean regions as *R. bedriagae*. Their recognition of *P. bedriagae* and *P. ridibundus* in Turkey conforms to our conclusion, but synonymization of *P. caralitanus* with *P. bedriagae* requires some considerations. Schneider and Sinsch (1999) actually found significantly lower dominant frequency of mating calls in *P. caralitanus* than in other species, but they ascribed this difference to the bigger size of *P. caralitanus*. If indeed the growth pattern such as the size at sexual maturity differs among water frogs, resultant

frequency difference in mating calls can be regarded as meaningful in determining species relationships. Thus, the findings of Schneider and Sinsch (1999) may need to be reevaluated. At the same time, because their sampling of calls within Turkey was not necessarily adequate, denser sampling is required to reach more convincing taxonomic conclusion for the water frogs in the country.

Sinsch and Schneider (1999) also compared morphological features of *P. caralitanus* with topotypic specimens of *P. ridibundus* and *P. bedriagae* from Kazakhstan and Syria, respectively. They concluded that *P. caralitanus* is conspecific with *P. bedriagae* simply because they considered ventral coloration is generally variable among frogs. In contrast, Jdeidi et al. (2001), by similarly performing morphological comparison of water frogs, but in a wider range of Turkey, recognized distinct specific status of *P. caralitanus* and reported the syntopic occurrence of *P. caralitanus* with *P. bedriagae*.

More recently, Akın et al. (2010a)

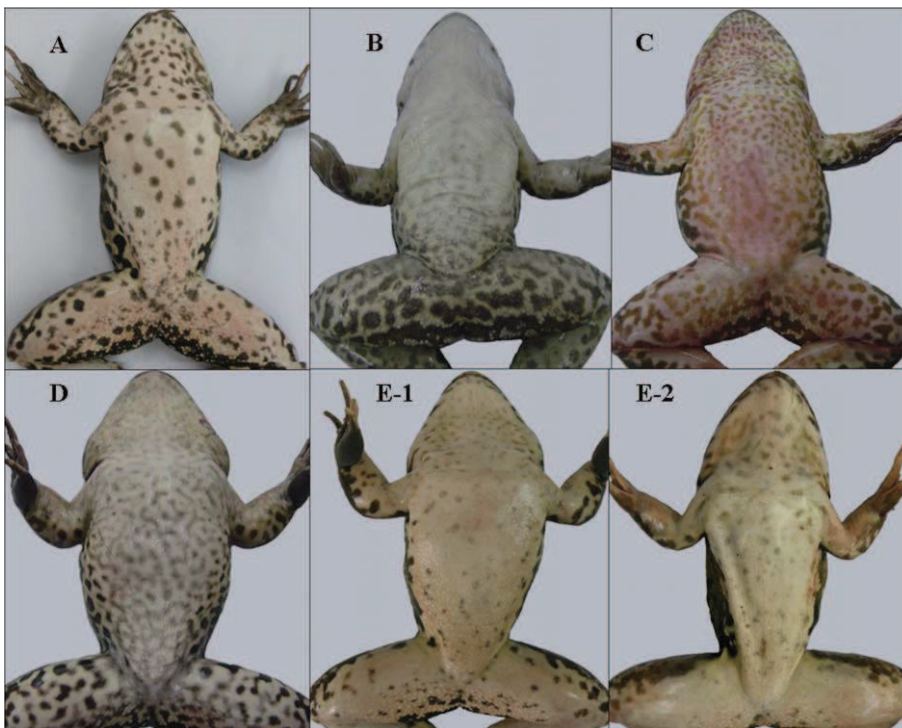

**Fig. 3.** Ventral color variation among five genetic groups recognized. (A) Clade A, (B) Subclade B1, (C) Lineage B2-1, (D) Lineage B2-2a, (E-1 and E-2) Lineage B2-2b. Not to scale.

examined the relationships between mtDNA haplotype and ventral colour in water frogs from localities surrounding the type locality of *R. r. caralitana* (*P. caralitanus*). They found a monophyly of the *caralitana* haplotypes in their phylogenetic tree from short sequences of mitochondrial ND3 gene (340-bp). However, some frogs in this clade did not exhibit orange-colored venters, the unique character of *P. caralitanus*. At the same time, some frogs with non-*caralitana* haplotypes possessed an orange-colored venter. Akin et al. (2010a) considered this discordance in mtDNA haplotype and ventral coloration as a result of unidirectional genetic introgression in periphery regions of Beyşehir Lake, and rejected identification of *P. caralitanus* solely on the basis of ventral colour or mtDNA haplotype. They, however, did not give any conclusive idea about the taxonomic relationships among these frogs, but suggested the necessity of further studies including those on morphometric ratios, mating call parameters, and nuclear markers.

Akin et al. (2010a) used "*Rana (ridibunda) caralitana*, 1988 Arıkan" in the title of their paper, but this has no taxonomic meaning. From the sampling localities and positions on the phylogenetic tree, *caralitana* and non-*caralitana* lineages in Akin et al. (2010a) clearly correspond to our Lineages B2-1 and B2-2, respectively. If indeed reciprocal genetic introgression through hybridization between the *caralitana* (B2-1) and the non-*caralitana* (B2-2) lineages occurs as suggested by Akin et al. (2010a), these two lineages could be considered as conspecific, but different subspecies, because they consist of interbreeding, basically geographically isolated populations (Mayr and Ashlock, 1991). Because one of two sublineages in Lineage B2-2 (B2-2b) forms a monophyletic clade with *P. bedriagae* from Syria (type locality of the species) in an analysis with the GenBank data of the species (DQ474181), the Lineages B2-1 and B2-2 should be collectively identified as *P. bedriagae*. Thus, we recommend the use of *P. bedriagae caralitanus* instead of *P. caralitanus* for our Lineage B2-1.

Finally, Lineage B2-2 contained two distinct lineages, B2-2a and B2-2b, but they are allopatric and genetically not much divergent (p-distance in 16S rRNA < 1%). We therefore consider them consubspecific at the moment, and call them *P. b. bedriagae*.

In conclusion, we suggest that three distinct species, *P. ridibundus*, unnamed species, and *P. bedriagae* (*P. b. bedriagae* and *P. b. caralitanus*), should be recognized as water frogs of Turkey.

#### ACKNOWLEDGMENTS

This study was supported financially by the Karadeniz Technical University Scientific Researches Unit (2008.111.04.9) to UB, and by grants from The Monbukagakusho through the Japanese Society for the Promotion of Sciences (JSPS: Field Research, 20405013) to MM. UB has received a scholarship funded by The Council of Higher Education, Turkey (YÖK) for 1-year post-doctoral study at Kyoto University. For laboratory assistance, UB thanks to Dr. Norihiro Kuraishi. We thank two anonymous reviewers for improving the manuscript.

#### REFERENCES

Akin Ç, Bilgin M, Bilgin CC (2010a) Discordance between ventral colour and mtDNA haplotype in the water frog *Rana (ridibunda) caralitana*, 1988 Arıkan. *Amphibia-Reptilia* 31: 9–20

- Akin Ç, Bilgin CC, Beerli P, Westaway R, Ohst T, Litvinchuk SN, et al. (2010b) Phylogeographic patterns of genetic diversity in eastern Mediterranean water frogs were determined by geological processes and climate change in the Late Cenozoic. *J Biogeogr* 37: 211–2124
- Arıkan H (1988) On a new form of *Rana ridibunda* from Turkey. *İstanbul Univ Fen Fak Mec* 53: 81–87
- Atatür M, Arıkan H, Mermer A (1990) A taxonomical investigation on the *Rana ridibunda* Pallas, 1771 (Anura: Ranidae) populations from the Lakes District- Anatolia. *İstanbul Univ Fen Fak Mec* 54: 79–83
- Ayaz D, Tok CV, Mermer A, Tosunoğlu M, Afsar M, Çiçek K (2006) A new locality for *Rana ridibunda caralitana* Arıkan, 1988 (Anura: Ranidae) in the Central Anatolia. *Ege Univ J Fish Aquat Sci* 23: 181–183
- Başıoğlu M, Özeti N (1973) Amphibians of Turkey. *Ege Univ Fen Fak Kit Ser* 50: 1–155
- Bodenheimer FS (1944) Introduction into the knowledge of the Amphibia and Reptilia of Turkey. *Rev Fac Sci İstanbul Univ* 9: 1–83
- Dubois O, Ohler A (1996 "1994") Frogs of the subgenus *Pelophylax* (Amphibia, Anura, Genus *Rana*): a catalogue with comments on name-bearing types, complete synonymies, proposed common names, and maps showing all type localities. *Zool Polonica* 39: 139–204
- Farris JS, Källersjö M, Kluge AG, Bult C (1995) Constructing a significance test for incongruence. *Syst Biol* 44: 570–572
- Felsenstein J (1981) Evolutionary trees from DNA sequences: a maximum likelihood approach. *J Mol Evol* 17: 368–376
- Fouquet A, Gilles A, Vences M, Marty C, Blanc M, Gemmel NJ (2007) Underestimation of species richness in neotropical frogs revealed by mtDNA analyses. *PLoS ONE* 2: e1109
- Franzen M, Bußmann M, Kordges T, Thiesmeier B (2008) Die Amphibien und Reptilien der Südwest-Türkei. *Laurenti-Verlag, Bielefeld*
- Frost DR (2011) Amphibian species of the world: an online reference. Version 5.5 (31 January, 2011). Electronic Database accessible at <http://research.amnh.org/vz/herpetology/amphibia/> *Am Mus Nat Hist*, New York
- Frost DR, Grant T, Faivovich J, Bain R, Haas A, Haddad CFB, et al. (2006) The amphibian tree of life. *Bull Am Mus Nat Hist* 297: 1–370
- Hall TA (1999) BioEdit: a user-friendly biological sequence alignment editor and analysis program for Windows 95/98/NT. *Nucleic Acids Symp Ser* 41: 95–98
- Hedges SB (1994) Molecular evidence for the origin of birds. *Proc Natl Acad Sci USA* 91: 2621–2624
- Hillis DM, Moritz C, Mable BK (1996) *Molecular Systematics*. 2nd ed, Sinauer Assoc, Sunderland, Massachusetts
- Huelsenbeck JP, Hillis DM (1993) Success of phylogenetic methods in the four-taxon case. *Syst Biol* 42: 247–264
- Huelsenbeck JP, Ronquist F (2001) MR BAYES: Bayesian inference of phylogeny. *Bioinformatics* 17: 754–755
- Jdeidi T, Bilgin C, Kence M (2001) New localities extend the range of *Rana bedriagae caralitana* Arıkan, 1988 (Anura: Ranidae) further west and suggest specific status. *Turk J Zool* 25: 153–158
- Jobb G (2008) Treefinder version of April 2008, software distributed by the author at <http://www.treefinder.de/>
- Joerman G, Baran I, Schneider H (1998) The mating call of *Rana ridibunda* (Amphibia: Anura) in Western Turkey: Bioacoustic analysis and taxonomic consequences. *Zool Anz* 220: 225–232
- Kimura M (1980) A simple method for estimating evolutionary rates of base substitutions through comparative studies of nucleotide sequences. *J Mol Evol* 16: 111–120
- Leaché AD, Reeder TW (2002) *Molecular systematics of the eastern fence lizard (Sceloporus undulatus): a comparison of parsimony*

- mony, likelihood, and Bayesian approaches. *Syst Biol* 51: 44–68
- Matsui M, Ito H, Shimada T, Ota H, Saidapur SK, Khonsue W, et al. (2005) Taxonomic relationships within the pan-oriental narrow-mouth toad *Microhyla ornata* as revealed by mtDNA analysis. *Zool Sci* 22: 489–495
- Matsui M, Shimada T, Liu WZ, Maryati M, Khonsue W, Orlov N (2006) Phylogenetic relationships of the oriental torrent frogs of the genus *Amolops* and its allies (Amphibia, Anura, Ranidae). *Mol Phylogenet Evol* 38: 659–666
- Mayr E, Ashlock PD (1991) *Principles of Systematic Zoology*. 2nd ed, McGraw-Hill, New York
- Mueller RL (2006) Evolutionary rates, divergence dates, and the performance of mitochondrial genes in Bayesian phylogenetic analysis. *Syst Biol* 55: 289–300
- Palumbi SR, Martin A, Romano S, McMillan WO, Stice L, Graybeal G (1991) The simple fool's guide to PCR, Version 2.0. Privately published. Compiled by Palumbi, S., Department of Zoology, University of Hawaii, Honolulu
- Plötner J, Ohst T, Böhme W, Schreiber R (2001) Divergence in mitochondrial DNA of Near Eastern water frogs with special reference to the systematic status of Cypriote and Anatolian populations (Anura, Ranidae). *Amphibia-Reptilia* 22: 397–412
- Rambaut A, Drummond AJ (2007) *Tracer* v1.4. <http://beast.bio.ed.ac.uk/Tracer>
- Schneider H, Sinsch U (1999) Taxonomic reassessment of Middle Eastern water frogs: Bioacoustic variation among populations considered as *Rana ridibunda*, *R. bedriagae* or *R. levantina*. *J Zool Syst Evol Res* 37: 57–65
- Schneider H, Sinsch U, Nevo E (1992) The lake frogs in Israel represent a new species. *Zool Anz* 228: 97–106
- Shaffer HB, McKnight ML (1996) The polytypic species revisited: genetic differentiation and molecular phylogenetics of the tiger salamander *Ambystoma tigrinum* (Amphibia: Caudata) complex. *Evolution* 50: 417–433
- Shimada T, Matsui M, Yambun P, Sudin A (2011) A taxonomic study of Whitehead's torrent frog, *Meristogenys whiteheadi*, with descriptions of two new species (Amphibia: Ranidae). *Zool J Linn Soc Lond* 161: 157–183
- Sinsch U, Schneider H (1999) Taxonomic reassessment of Middle Eastern water frogs: Morphological variation among populations considered as *Rana ridibunda*, *R. bedriagae* or *R. levantina*. *J Zool Syst Evol Res* 37: 67–73
- Swofford DL (2000) *PAUP\* Phylogenetic Analysis Using Parsimony (\*and Other Methods)*, Version 4. Sinauer Assoc, Sunderland, Massachusetts
- Tamura K, Nei M (1993) Estimation of the number of nucleotide substitutions in the control region of mitochondrial DNA in humans and chimpanzees. *Mol Biol Evol* 10: 512–526
- Tamura K, Peterson D, Peterson N, Stecher G, Nei M, Kumar S (2011) MEGA5: Molecular evolutionary genetics analysis using maximum likelihood, evolutionary distance, and maximum parsimony methods. *Mol Biol Evol* 28: 2731–2739
- Tanabe AS (2007) KAKUSAN: a computer program to automate the selection of a nucleotide substitution model and configuration of a mixed model on multilocus data. *Mol Ecol Notes* 7: 962–964
- Tanaka T, Matsui M, Takenaka O (1994) Estimation of phylogenetic relationships among Japanese brown frogs from mitochondrial cytochrome b gene (Amphibia: Anura). *Zool Sci* 11: 753–757
- Tanaka-Ueno T, Matsui M, Sato T, Takenaka S, Takenaka O (1998) Local population differentiation and phylogenetic relationships of Russian brown frog, *Rana amurensis* inferred by mitochondrial cytochrome b gene sequences (Amphibia, Ranidae). *Jpn J Herpetol* 17: 91–97
- Tavaré S (1986) Some probabilistic and statistical problems in the analysis of DNA sequences. *Lec Math Life Sci* 17: 57–86
- Wilkinson JA, Drewes RC, Tatum OL (2002) A molecular phylogenetic analysis of the family Rhacophoridae with an emphasis of the Asian and African genera. *Mol Phylogenet Evol* 24: 265–273
- Xia X, Xie Z (2001) DAMBE: a data analysis in molecular biology and evolution. *J Hered* 92: 371–373

(Received April 26, 2011 / Accepted July 17, 2011)

# Highly Complex Mitochondrial DNA Genealogy in an Endemic Japanese Subterranean Breeding Brown Frog *Rana tagoi* (Amphibia, Anura, Ranidae)

Koshiro Eto<sup>1</sup>, Masafumi Matsui<sup>1\*</sup>, Takahiro Sugahara<sup>2</sup>, and Tomoko Tanaka-Ueno<sup>3</sup>

<sup>1</sup>Graduate School of Human and Environmental Studies, Kyoto University, Kyoto 606-8501, Japan

<sup>2</sup>Hazama-cho 1740-1, Hachioji, Tokyo 193-0941, Japan

<sup>3</sup>Center for Liberal Arts, Meijigakuin University, Kamikurata 1518, Totsuka, Yokohama 244-8539, Japan

The endemic Japanese frog *Rana tagoi* is unique among Holarctic brown frogs in that it breeds in small subterranean streams. Using mitochondrial 16S ribosomal RNA and NADH dehydrogenase subunit 1 genes, we investigated genealogical relationships among geographic samples of this species together with its relative *R. sakuraii*, which is also a unique stream breeder. These two species together form a monophyletic group, within which both are reciprocally paraphyletic. *Rana tagoi* is divided into two major clades (Clade A and B) that are composed of 14 genetic groups. *Rana sakuraii* is included in Clade A and split into two genetic groups, one of which forms a clade (Subclade A-2) with sympatric *R. tagoi*. This species-level paraphyly appears to be caused by incomplete taxonomy, in addition to introgressive hybridization and/or incomplete lineage sorting. *Rana tagoi* strongly differs from other Japanese anurans in its geographic pattern of genetic differentiation, most probably in relation to its unique reproductive habits. Taxonomically, *R. tagoi* surely includes many cryptic species.

**Key words:** *Rana tagoi*, Japan, mtDNA, paraphyly, cryptic species, subterranean breeding, genetic divergence

## INTRODUCTION

The genus *Rana* historically represented a very large group of frogs that occurred almost worldwide (Boulenger, 1920; Frost, 1985; Dubois, 1992), but is now restricted to smaller number of Holarctic brown frogs (Frost et al., 2006) that are generally similar in adult morphology and ecology. Most congeners breed in still (lentic) waters, such as ponds and rice paddies (e.g., *R. temporaria* Linnaeus from Europe: Nöllert and Nöllert, 1992), and only a few (e.g., *R. graeca* Boulenger from Europe and *R. sauteri* Boulenger from Taiwan) in flowing (lotic) waters of open streams (Nöllert and Nöllert, 1992; Tanaka-Ueno et al., 1998). Compared with such species, Japanese *R. tagoi* Okada (type locality: restricted by Shibata [1988] to Kamitakara-mura, currently included in Takayama-shi, Gifu Prefecture) is unique in that it breeds in small underground streams (Maeda and Matsui, 1999). This subterranean breeding habit is highly specialized and is not known in any other congeneric species.

*Rana tagoi* is endemic to the main (Honshu, Shikoku, and Kyushu) and some adjacent, smaller (Yakushima, Oki, and Goto) islands of Japan. Eggs laid in subterranean streams are few in number and large in size, and once hatched tadpoles can metamorphose without feeding

(Maeda and Matsui, 1999). Such traits appear to be an adaptation to this unique breeding environment. Another brown frog, *R. sakuraii* Matsui and Matsui (type locality: Okutama-machi, Nishitama-gun, Tokyo Prefecture) occurs only on Honshu Island and breeds in wider open streams in mountain regions. Other than the difference in breeding environment, this species is generally similar to *R. tagoi* in morphology and ecology, and is thought to be a close relative of *R. tagoi*, having originated from a *R. tagoi*-like subterranean breeding ancestor (Maeda and Matsui, 1999).

Steep mountains that provide many streams and rivers occupy the larger part of the main islands of Japan. Reflecting this environmental trait, there are various amphibian species that are adapted to lotic environments (e.g., *Bufo torrenticola* Matsui; *Buergeria buergeri* [Temminck and Schlegel]). Recent extensive surveys have revealed high cryptic diversity in some lotic breeding salamanders of the genera *Hynobius* Tschudi and *Onychodactylus* Tschudi (Nishikawa et al., 2007; Yoshikawa et al., 2008). A similar situation is expected in the case of lotic breeding *R. tagoi*, as the species is unique among Japanese frogs in that it contains three distinct subspecies (*R. t. tagoi* from main islands of Japan, *R. t. okiensis* Daito from Oki Islands, and *R. t. yakushimensis* Nakatani and Okada from Yakushima Island). In addition, morphological, breeding ecological (Sugahara, 1990; Sugahara and Matsui, 1992, 1993, 1994, 1995, 1996, 1997), and karyological (Ryuzaki et al., 2006) variations reported within *R. t. tagoi* suggest that it includes cryptic species. Genetically, *R. tagoi* is also diversified as

\* Corresponding author. Tel. : +81-75-753-6846;  
Fax : +81-75-753-6846;  
E-mail: fumi@zoo.zool.kyoto-u.ac.jp

shown by the analyses of allozymes (Nishioka et al., 1987) and mitochondrial DNA (mtDNA; Tanaka et al., 1994). In contrast, variations within *R. sakuraii* have been poorly studied.

These previous studies suggest the presence of phylogenetic and/or taxonomic problems in *R. tagoi*, while such information is lacking for *R. sakuraii*. To date, few studies (e.g., Ryuzaki et al., 2006) have compared a large number of samples from the entire distributional range of the two species, leaving the comprehensive patterns of intra- or inter-specific variations unresolved. In this study, we conducted a phylogenetic analysis using two mitochondrial genes, relatively conservative 16S ribosomal RNA (16S rRNA) and rapidly evolving NADH dehydrogenase subunit 1 (ND1; Mueller, 2006), to reveal patterns of genetic differentiation and genealogical relationships in terms of mtDNA among samples of *R. tagoi* and *R. sakuraii*.

### MATERIALS AND METHODS

We collected 183 specimens of *R. t. tagoi*, including the topotypic population, from 145 localities covering its entire distributional range in Honshu, Shikoku, and Kyushu. The large and small types of *R. t. tagoi* from Kinki (Sugahara, 1990) were distinguished

according to the diagnosis of Sugahara and Matsui (1994). We also collected two specimens of *R. t. yakushimensis* from Yakushima Island and three specimens of *R. t. okiensis* from the Oki islands. Furthermore, we collected 19 specimens of *R. sakuraii*, including the topotype, from 16 localities in Honshu. Detailed sampling localities are shown in Fig. 1 and Table 1.

As outgroups, we used *R. tsushimensis* from Tsushima Islands, Japan, and *Lithobates sylvaticus* from Quebec, Canada. The latter species is morphologically and ecologically similar to members of the genus *Rana*, but has been placed recently in another ranid genus, *Lithobates* (Frost et al., 2006).

Total DNA was extracted from frozen or ethanol-preserved tissues by standard phenol-chloroform extraction procedures (Hillis et al., 1996). Fragments containing the entire 16S rRNA and ND1 sequences, approximately 2.9 kb long, were amplified by polymerase chain reaction (PCR). The PCR cycle included an initial heating at 94°C for 4 min; 33 cycles of 94°C (30 s), 50°C (30 s), and 72°C (2 min 30 s); and a final extension at 72°C for 7 min. The amplified PCR products were purified by polyethylene glycol (PEG) precipitation procedures. The cycle sequence reactions were carried out with ABI PRISM Big Dye Terminator v3.1 Cycle sequencing Kit (Applied Biosystems) and sequencing was performed on an ABI 3130 automated sequencer. We used the primers listed in Table 2 to amplify and sequence the fragments, and all samples were sequenced in both directions. The obtained sequences were depos-

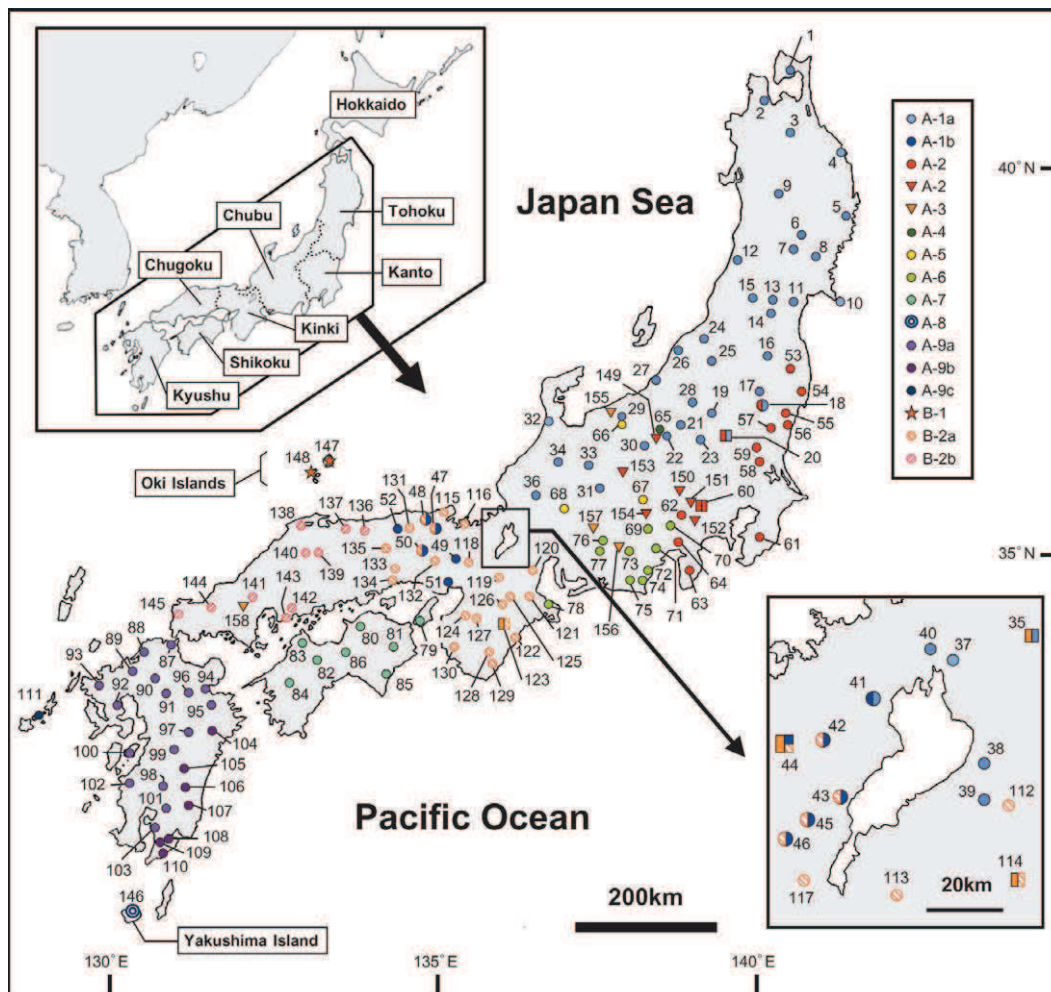

**Fig. 1.** Map of Japan showing sampling localities of *Rana t. tagoi* (circles), *R. t. yakushimensis* (double circle), *R. t. okiensis* (stars), and *R. sakuraii* (triangles). Squares indicate localities with sympatry of *R. t. tagoi* and *R. sakuraii*. For names of localities and genetic groups, see Table 1.



**Table 1.** Continued

| Sample no | Locality                       | genetic group | Voucher (KUHE) | GenBank  |          | Sample no                    | Locality                              | genetic group | Voucher (KUHE) | GenBank  |          |
|-----------|--------------------------------|---------------|----------------|----------|----------|------------------------------|---------------------------------------|---------------|----------------|----------|----------|
|           |                                |               |                | 16S rRNA | ND1      |                              |                                       |               |                | 16S rRNA | ND1      |
| 108       | Kimotsuki-cho, Kagoshima Pref. | A-9b          | 43397          | AB639533 | AB639700 | 141                          | Hatsukaichi-shi, Hiroshima Pref.      | B-2b          | UN             | AB639571 | AB639736 |
| 109a      | Kanoya-shi, Kagoshima Pref.    | A-9b          | 43401          | AB639534 | AB639701 | 142                          | Higashihiroshima-shi, Hiroshima Pref. | B-2b          | 30262          | AB639572 | AB639737 |
| 109b      |                                |               | 43403          | AB639535 | AB639702 | 143                          | Higashihiroshima-shi, Hiroshima Pref. | B-2b          | 30220          | AB639573 | AB639738 |
| 110a      | Kinko-cho, Kagoshima Pref.     | A-9b          | 27678          | AB639536 | AB639703 | 144                          | Hagi-shi, Yamaguchi Pref.             | B-2b          | 42848          | AB639574 | AB639739 |
| 110b      |                                |               | 41250          | AB639537 | AB639704 | 145                          | Shimonoseki-shi, Yamaguchi Pref.      | B-2b          | 34516          | AB639575 | AB639740 |
| 111       | Goto-shi, Nagasaki Pref.       | A-9c          | 31539          | AB639538 | AB639705 | <i>R. t. yakushimensis</i>   |                                       |               |                |          |          |
| 112a      | Taga-cho, Shiga Pref.          | B-2a          | 43508          | AB639539 | AB639706 | 146a                         | Yakushima-cho, Kagoshima Pref.        | A-8           | 10182          | AB639578 | AB639741 |
| 112b      |                                |               | 43509          | AB639540 | AB639707 | 146b                         |                                       |               | 43326          | AB639577 | AB639741 |
| 113       | Konan-shi, Shiga Pref.         | B-2a          | 18763          | AB639541 | AB639708 | <i>R. t. okiensis</i>        |                                       |               |                |          |          |
| 114a      | Koka-shi, Shiga Pref.          | B-2a          | 28466          | AB639542 | AB639709 | 147a                         | Okinoshima-cho, Shimane Pref.         | B-1           | 10818          | AB639576 | AB639742 |
| 115       | Kyotango-shi, Kyoto Pref.      | B-2a          | 24566          | AB639544 | AB639729 | 147b                         |                                       |               | 22341          | AB639579 | AB639742 |
| 116       | Maizuru-shi, Kyoto Pref.       | B-2a          | TMP_T3345      | AB639545 | AB639711 | 148                          | Nishinoshima-cho, Shimane Pref.       | B-1           | 43647          | AB639580 | AB639742 |
| 117a      | Kyoto-shi, Kyoto Pref.         | B-2a          | 27168          | AB639546 | AB639712 | <i>R. sakuraii</i>           |                                       |               |                |          |          |
| 117b      |                                |               | 41431          | AB639547 | AB639713 | 20b                          | Kanuma-shi, Tochigi Pref.             | A-2           | 43635          | AB639423 | AB639744 |
| 118       | Kameoka-shi, Kyoto Pref.       | B-2a          | 41553          | AB639548 | AB639713 | 35b                          | Ibigawa-cho, Gifu Pref.               | A-3           | 36297          | AB639437 | AB639620 |
| 119       | Joyo-shi, Kyoto Pref.          | B-2a          | 41554          | AB639549 | AB639714 | 44d                          | Nantan-shi, Kyoto Pref.               | A-3           | UN             | AB639454 | AB639631 |
| 120       | Komono-cho, Mie Pref.          | B-2a          | 26744          | AB639550 | AB639715 | 44e                          |                                       |               | 41412          | AB639455 | AB639632 |
| 121       | Matsuzaka-shi, Mie Pref.       | B-2a          | 41484          | AB639551 | AB639716 | 44f                          |                                       |               | 41413          | AB639456 | AB639632 |
| 122       | Owase-shi, Mie Pref.           | B-2a          | 26990          | AB639552 | AB639717 | 60b                          | Akiruno-shi, Tokyo Pref.              | A-2           | 42450          | AB639583 | AB639744 |
| 123a      | Odai-cho, Mie Pref.            | B-2a          | 40190          | AB639553 | AB639718 | 114b                         | Koka-shi, Shiga Pref.                 | A-3           | TMP_T2666      | AB639543 | AB639710 |
| 124       | Izumi-shi, Osaka Pref.         | B-2a          | TMP_T3425      | AB639556 | AB639721 | 123b                         | Odai-cho, Mie Pref.                   | A-3           | 27647          | AB639554 | AB639719 |
| 125       | Soni-mura, Nara Pref.          | B-2a          | 24435          | AB639557 | AB639722 | 123c                         |                                       |               | 40309          | AB639555 | AB639720 |
| 126       | Sakurai-shi, Nara Pref.        | B-2a          | 18893          | AB639558 | AB639723 | 149                          | Naganohara-machi, Gunma Pref.         | A-2           | 27937          | AB639581 | AB639744 |
| 127       | Kudoyama-cho, Wakayama Pref.   | B-2a          | 24546          | AB639559 | AB639724 | 150                          | Chichibu-shi, Saitama Pref.           | A-2           | 43736          | AB639582 | AB639743 |
| 128       | Hongu-cho, Wakayama Pref.      | B-2a          | 26784          | AB639560 | AB639725 | 151                          | Okutama-machi, Tokyo Pref.            | A-2           | UN             | AB639583 | AB639744 |
| 129       | Shingu-shi, Wakayama Pref.     | B-2a          | 24540          | AB639561 | AB639727 | 152                          | Kiyokawa-mura, Kanagawa Pref.         | A-2           | 14276          | AB639584 | AB639745 |
| 130       | Gobo-shi, Wakayama Pref.       | B-2a          | 41229          | AB639562 | AB639728 | 153                          | Matsumoto-shi, Nagano Pref.           | A-2           | 22887          | AB639585 | AB639746 |
| 131       | Kami-cho, Hyogo Pref.          | B-2a          | 43603          | AB639563 | AB639729 | 154                          | Fujikawa-cho, Yamanashi Pref.         | A-2           | 43481          | AB639586 | AB639747 |
| 132       | Taka-cho, Hyogo Pref.          | B-2a          | 10330          | AB639564 | AB639730 | 155                          | Itoigawa-shi, Niigata Pref.           | A-3           | 31300          | AB639587 | AB639748 |
| 133       | Sayo-cho, Hyogo Pref.          | B-2a          | 41021          | AB639565 | AB639731 | 156                          | Hamamatsu-shi, Shizuoka Pref.         | A-3           | UN             | AB639588 | AB639749 |
| 134       | Kamigori-cho, Hyogo Pref.      | B-2a          | 41022          | AB639566 | AB639732 | 157                          | Nakatsugawa-shi, Gifu Pref.           | A-3           | 18201          | AB639589 | AB639749 |
| 135       | Mimasaka-shi, Okayama Pref.    | B-2a          | 27659          | AB639567 | AB639734 | 158                          | Iwakuni-shi, Yamaguchi Pref.          | A-3           | 43893          | AB639590 | AB639750 |
| 136       | Misasa-cho, Tottori Pref.      | B-2b          | 24574          | AB639568 | AB639733 | <i>R. tsushimensis</i>       |                                       |               |                |          |          |
| 137       | Daisen-cho, Tottori Pref.      | B-2b          | 36824          | AB639569 | AB639734 |                              | Tsushima-shi, Nagasaki Pref.          |               | 11606          | AB639592 | AB639752 |
| 138       | Unnan-shi, Shimane Pref.       | B-2b          | 18877          | AB639570 | AB639735 | <i>Lithobates sylvaticus</i> |                                       |               |                |          |          |
| 139a      | Shobara-shi, Hiroshima Pref.   | B-2b          | 36037          | AB639571 | AB639735 |                              | Quebec, Canada                        |               | UN             | AB639591 | AB639751 |
| 139b      |                                |               | 36040          | AB639572 | AB639735 |                              |                                       |               |                |          |          |
| 140       | Shobara-shi, Hiroshima Pref.   | B-2b          | 24553          | AB639573 | AB639735 |                              |                                       |               |                |          |          |

ited in GenBank (Table 1).

Sequences obtained were aligned using Clustal W (Thompson et al., 1994), and gaps and ambiguous areas were excluded from alignments using Gblocks 0.91b (Castresana, 2000) with default settings. We then constructed phylogenetic trees from the combined alignments using maximum parsimony (MP), maximum likelihood (ML), and Bayesian inference (BI). The MP analysis was performed using PAUP\*4.0b10 (Swofford, 2002). We used a heuristic search with the tree bisection and reconnection (TBR) branch-swapping algorithm and 100 random additions replicates, and the number of saved trees was restricted to 5,000. Transitions and transversions were equally weighted. The ML and BI analyses were respectively performed using TREEFINDER ver. Oct. 2008 (Jobb, 2008) with Phylogears 1.5.2010.03.24 (Tanabe, 2008) and MrBayes 3.1.2 (Huelsenbeck and Ronquist, 2001). Different substitution models were applied for each gene partition in both of the analyses. The optimum substitution model for each gene was selected by using Kakusan4 (Tanabe, 2010), based on the Akaike information criterion (AIC). The best model was calculated for each codon position (1st, 2nd, and 3rd positions) of the ND1 genes. In the BI analysis, two independent runs of four Markov chains were conducted for 7,000,000 generations (sampling frequency: one tree per 100 generations).

We used TRACER v. 1.4 (Rambaut and Drummond, 2007) to determine the burn-in size and when the log likelihood of sampled trees reached stationary distribution, and the first 7,001 trees were discarded (burn-in = 700,000).

The robustness of the MP and ML trees were tested using non-parametric bootstrap analysis (Felsenstein 1985) with 1,000 replicates. We regarded tree topologies with bootstrap value (BS) 70% or greater as sufficiently supported (Huelsenbeck and Hillis, 1993). For the BI, we regarded Bayesian posterior probability (BPP) 0.95 or greater as significant support (Huelsenbeck and Ronquist, 2001;

**Table 2.** Primers used to amplify mtDNA in this study.

| Target | Name        | Sequence                     | Reference               |
|--------|-------------|------------------------------|-------------------------|
| 16S    | L1507       | TACACACCGCCCGTCACCCTCTT      | Shimada et al. (2011)   |
|        | H1923       | AAGTAGCTCGCTTAGTTTCGG        | Shimada et al. (2011)   |
|        | L1879       | CGTACCTTTTGCATCATGGTC        | Shimada et al. (2011)   |
|        | H2315       | TTCTTGTTACTAGTTCTAGCAT       | Shimada et al. (2011)   |
|        | L2188       | AAAGTGGGCCTAAAAGCAGCCA       | Matsui et al. (2006)    |
|        | Wilkinson_6 | CCCTCGGTGATGCCGTTGATAC       | Wilkinson et al. (2002) |
|        | 16L1        | CTGACCGTCAAAAGGTAGCGTAATCACT | Hedges (1994)           |
|        | 16H1        | CTCCGGTCTGAACTCAGATCACGTAGG  | Hedges (1994)           |
| ND1    | L3032       | CGACCTCGATGTTGGATCAGG        | Shimada et al. (2011)   |
|        | ND1_Htago   | GRGCRATTTTGGAGTTTGARGCTCA    | this study              |
|        | ND1_Ltago   | GACCTAAACCTCAGYATYCTATTTAT   | this study              |
|        | tMet_H      | AGGAAGTACAAAGGGTTTGTGATC     | Shimada et al. (2011)   |



Leaché and Reeder 2002). Uncorrected p-distances for each gene were also calculated using PAUP\* ver. 4.0b10.

**RESULTS**

**Sequences and statistics**

We obtained complete 16S rRNA (1,625 bp long) and ND1 (973 bp) sequences from 207 individuals and two out-group taxa. After excluding gaps and ambiguous areas, a combined 2,521 nucleotide sites, of which 624 were variable

**Table 3.** Alignment statistics for total 16S rRNA and ND1. The number of base pairs (bp), variable sites (vs), number of parsimony informative sites (pi), and transition-transversion ratio (ti/tv) are given for ingroups only.

|          | bp   | vs  | pi  | ti/tv |
|----------|------|-----|-----|-------|
| 16SrRNA  | 1554 | 310 | 206 | 6.65  |
| ND1      | 967  | 314 | 250 | 9.38  |
| Combined | 2521 | 624 | 456 | 8.04  |

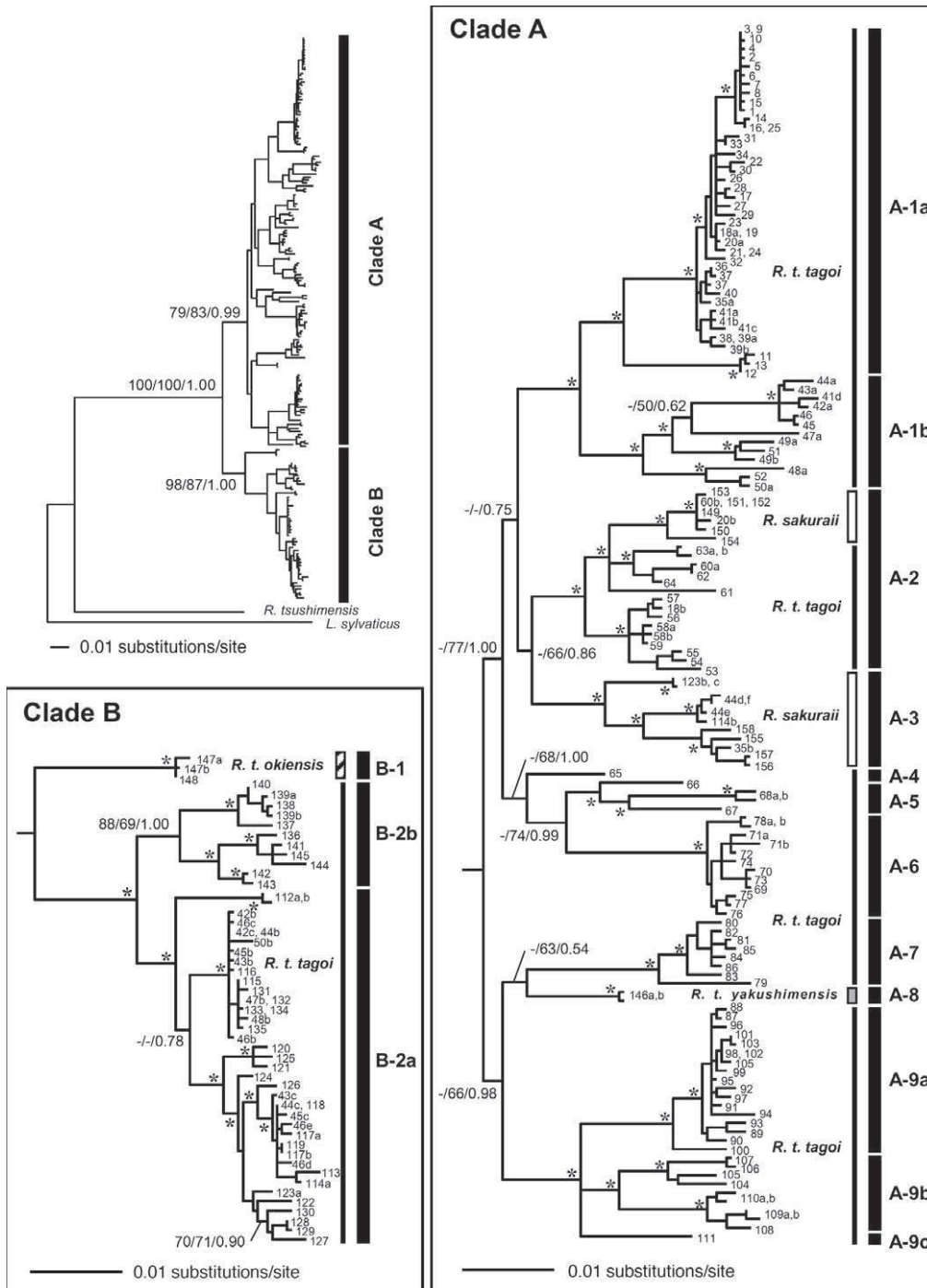

**Fig. 2.** Bayesian tree of total 16S rRNA and ND1 mitochondrial genes for three subspecies of *R. tagoi*, *R. sakuraii*, and outgroup taxa. Nodal values indicate bootstrap supports for MP and ML, and Bayesian posterior probability (MP-BS/ML-BS/BPP). Asterisks indicate nodes with MP-BS and ML-BS = 70% and BPP = 0.95. For locality numbers, see Table 1 and Fig. 1.

and 456 parsimoniously informative (Table 3), were used for phylogenetic analysis. We detected 190 haplotypes within the ingroup, of which 168 were in *R. t. tagoi*, two in *R. t. yakushimensis*, three in *R. t. okiensis*, and 17 in *R. sakuraii*.

The MP analysis produced 5,000 equally most parsimonious trees (L = 2007, CI = 0.519, RI = 0.901). For the ML analysis, the best substitution model of 16S rRNA estimated by Kakusan 4 was J2 model with a Gamma (G) shape parameter. In ND1, Hasegawa-Kishino-Yano-1985 (HKY85) model + G, HKY85 + G, and J2 + G were selected for the 1st, 2nd, and 3rd codon positions, respectively. For the BI analysis, the general time reverse (GTR) model + G was selected for 16S rRNA. In ND1, HKY85 + G, HKY85 + G, and GTR + G were selected for the 1st, 2nd, and 3rd codon positions, respectively. The likelihood values (-lnL) of the ML and BI trees were 14439.77 and 15102.97, respectively.

#### Phylogenetic relationships

The ML and BI analyses yielded essentially identical topologies. The MP tree was also similar to these, although support values tended to be lower. The BI tree is shown in Fig. 2. *Rana tagoi* and *R. sakuraii* formed a fully supported monophyletic group, but both were paraphyletic with respect to each other. The ingroup was divided into two major clades, Clade A (MP-BS = 79%, ML-BS = 83%, BPP = 0.99) and Clade B (98%, 87%, 1.00, respectively), with uncorrected p-distances of 2.1% to 3.9% in 16S rRNA and 4.9% to 8.5% in ND1 between them. Each clade contained several subclades, some of which were further divided into two or three groups. Sequence divergences as measured by the mean uncorrected p-distances among these subclades and groups are shown in Table 4.

Clade A, which contained a subset of *R. t. tagoi*, *R. t. yakushimensis*, and *R. sakuraii* samples, was divided into nine subclades (Subclade A-1 to A-9). Subclade A-1 (94%, 98%, 1.00) contained *R. t. tagoi* samples from Tohoku, northern Chubu, and northern Kinki regions. This subclade was divided into two groups, Group A-1a (97%, 99%, 1.00) and A-1b (96%, 99%, 1.00), with sequence divergences of 0.9% to 1.9% in 16S rRNA and 3.3% to 4.9% in ND1 between them.

Group A-1a contained *R. t. tagoi* from Tohoku, northern Chubu, and northeastern Kinki (localities 1 to 41), including topotypic samples (locality 33) and a part of the *R. t. tagoi* large type (Sugahara, 1990) (locality 41). Except for samples from localities 11 to 13, which were divergent from the others, genetic variation within Group A-1a was small, despite its wide range of distribution. Group A-1b consisted of all samples of the *R. t. tagoi* small type from northern Kinki (localities 41 to 52). Within this group, genetic variation among haplotypes was significant, and four divergent subgroups were recognized.

**Table 4.** Mean uncorrected p-distances (%) among genetic groups of three subspecies of *R. tagoi* and *R. sakuraii* for 16S rRNA (above diagonal) and ND1 (below diagonal). Darkly shaded areas indicate distances among groups with sympatric distribution and lightly shaded areas indicate distances among groups with parapatric distribution.

|                               | 1   | 2   | 3   | 4   | 5   | 6   | 7   | 8   | 9   | 10  | 11  | 12  | 13  | 14  | 15  | 16  |
|-------------------------------|-----|-----|-----|-----|-----|-----|-----|-----|-----|-----|-----|-----|-----|-----|-----|-----|
| 1. A-1a                       | –   | 1.3 | 1.6 | 1.9 | 1.6 | 1.4 | 1.5 | 1.9 | 1.9 | 1.7 | 1.8 | 2.0 | 1.7 | 3.0 | 3.3 | 3.0 |
| 2. A-1b                       | 4.1 | –   | 1.8 | 2.1 | 1.7 | 1.6 | 1.6 | 1.9 | 2.1 | 1.6 | 2.0 | 2.3 | 1.8 | 2.8 | 3.2 | 2.9 |
| 3. A-2 ( <i>R. t. tagoi</i> ) | 3.9 | 4.3 | –   | 1.1 | 1.7 | 1.3 | 1.6 | 1.9 | 1.9 | 1.7 | 1.9 | 2.2 | 1.8 | 2.9 | 3.1 | 2.8 |
| 4. A-2 ( <i>R. sakuraii</i> ) | 4.2 | 4.2 | 2.1 | –   | 1.9 | 1.4 | 1.8 | 2.0 | 2.1 | 1.9 | 2.1 | 2.4 | 2.1 | 3.0 | 3.1 | 2.8 |
| 5. A-3                        | 4.7 | 5.0 | 3.7 | 3.6 | –   | 1.4 | 1.5 | 1.9 | 2.1 | 1.8 | 1.9 | 2.2 | 1.8 | 2.7 | 3.0 | 2.6 |
| 6. A-4                        | 3.9 | 4.3 | 3.0 | 3.3 | 4.1 | –   | 1.3 | 1.7 | 1.8 | 1.5 | 1.7 | 2.0 | 1.6 | 2.7 | 2.8 | 2.6 |
| 7. A-5                        | 4.4 | 4.9 | 3.5 | 3.8 | 4.4 | 3.0 | –   | 1.5 | 2.1 | 1.7 | 2.0 | 2.3 | 1.9 | 2.9 | 3.1 | 2.8 |
| 8. A-6                        | 5.0 | 4.7 | 4.3 | 4.3 | 5.4 | 3.4 | 4.1 | –   | 2.3 | 2.0 | 2.3 | 2.5 | 2.1 | 2.9 | 3.3 | 2.8 |
| 9. A-7                        | 4.7 | 5.2 | 3.8 | 4.4 | 5.1 | 4.1 | 4.7 | 5.3 | –   | 1.8 | 2.0 | 2.4 | 1.9 | 3.0 | 3.1 | 2.7 |
| 10. A-8                       | 4.0 | 4.4 | 3.1 | 3.4 | 3.9 | 2.8 | 3.6 | 4.0 | 3.1 | –   | 1.8 | 2.1 | 1.6 | 2.7 | 2.8 | 2.7 |
| 11. A-9a                      | 5.2 | 5.3 | 4.2 | 4.4 | 5.4 | 4.4 | 4.8 | 5.4 | 4.4 | 3.4 | –   | 1.7 | 1.3 | 3.2 | 3.2 | 2.9 |
| 12. A-9b                      | 4.7 | 5.1 | 3.8 | 4.1 | 4.8 | 3.7 | 4.2 | 4.9 | 4.1 | 2.8 | 3.0 | –   | 1.4 | 3.3 | 3.5 | 3.1 |
| 13. A-9c                      | 5.0 | 5.2 | 4.1 | 3.9 | 5.0 | 4.0 | 4.7 | 5.3 | 4.1 | 3.3 | 3.2 | 2.9 | –   | 2.9 | 3.1 | 2.8 |
| 14. B-1                       | 6.1 | 6.4 | 5.6 | 6.0 | 6.5 | 5.3 | 5.9 | 6.1 | 5.9 | 5.4 | 6.3 | 6.2 | 6.4 | –   | 2.0 | 1.8 |
| 15. B-2a                      | 6.9 | 6.7 | 5.9 | 6.3 | 6.5 | 5.9 | 6.3 | 6.7 | 6.3 | 5.8 | 6.7 | 6.6 | 6.6 | 4.1 | –   | 1.3 |
| 16. B-2b                      | 7.0 | 6.9 | 5.7 | 6.1 | 7.0 | 5.9 | 6.5 | 6.6 | 6.3 | 6.0 | 6.4 | 6.4 | 6.4 | 4.4 | 2.9 | –   |

Subclade A-2 (96%, 99%, 1.00) contained *R. t. tagoi* from Kanto region (localities 18 and 53 to 64) and was divided into two divergent groups. Interestingly, *R. sakuraii* from eastern Honshu (localities 20, 60, and 149 to 154), including topotypic samples (locality 151), was completely embedded in one of these groups. Within Subclade A-2, *R. sakuraii* was not much divergent from *R. t. tagoi* (0.8% to 1.3% in 16S; 1.3% to 3.0% in ND1).

Subclade A-3 (99%, 99%, 1.00) contained *R. sakuraii* from western Honshu (localities 35, 44, 114, 123, and 155 to 158), and was divided into three groups. Subclades A-2 and A-3 tended to form a clade, but their monophyly was not supported (< 50%, 66%, 0.86).

Subclade A-4 contained only one sample of *R. t. tagoi* from Nakanojo-machi (former Kuni-mura), Gunma (locality 65), while Subclade A-5 (78%, 75%, 1.00) contained divergent haplotypes of *R. t. tagoi* from central Chubu (localities 66 to 68). Subclade A-6 (all 100%, or 1.00) contained *R. t. tagoi* from southern Chubu (localities 69 to 77) and Shima Peninsula (locality 78), where variation among haplotypes was small. This subclade included *R. t. tagoi* with 2n = 28 chromosomes (vs. 2n = 26 chromosomes in *R. tagoi* samples from other localities so far studied) from Neba-mura, Nagano (Ryuzaki et al., 2006; locality 76). Subclades A-4 to A-6 tended to form a clade, but their monophyly was not unambiguously supported (< 50%, 68%, 1.00). Subclades A-1 to A-6 also tended to form a clade, but the MP support of this node was low (< 50%, 77%, 1.00).

Subclade A-7 (99%, 99%, 1.00) contained *R. t. tagoi* from Shikoku (localities 80 to 86) and Awaji Island (locality 79), with small genetic variations within the group. Subclade A-8 (all 100%, or 1.00) contained *R. t. yakushimensis* from Yakushima Island (locality 146), and was close to Subclade A-7, although their monophyly was not supported (< 50%, 63%, 0.54).

Subclade A-9 (90%, 99%, 1.00) contained *R. t. tagoi* from Kyushu and tended to form a clade with A-7 and A-8 but their monophyly was not supported (< 50%, 66%, 0.98). Subclade A-9 was divided into three groups, Groups A-9a (99%, 100%, 1.00), A-9b (93%, 94%, 1.00), and A-9c (only

one sample) with divergences between them being 1.3% to 1.7% in 16S, and 2.9% to 3.2% in ND1. Group A-9a contained samples from northwestern Kyushu (localities 87 to 103), and genetic variation within the group was small. Group A-9b consisted of samples from southern Pacific side of the island (localities 104 to 110) and was divided into two subgroups. Group A-9c contained one sample from Narujima Island (locality 111).

Clade B contained *R. t. okiensis* and a part of *R. t. tagoi* samples and was divided into two subclades. One of them, Subclade B-1 (all 100% or 1.00) contained *R. t. okiensis* from Oki islands (localities 147 and 148), while another, Subclade B-2 (99%, 95%, 1.00), consisted of *R. t. tagoi* from western Honshu. Two groups, with divergences of 0.8% to 1.6% in 16S rRNA and 2.1% to 4.0% in ND1, were recognized within this subclade; Group B-2a (99%, 95%, 1.00) and Group B-2b (88%, 69%, 1.00). Group B-2a contained samples from Kinki (localities 42 to 48, 50, and 112 to 135) and was divided into three subgroups. A large portion of the *R. t. tagoi* large type (Sugahara, 1990) samples (localities 42 to 48 and 50) was included in this group. Group B-2b contained samples from Chugoku (localities 136 to 145) and was divided into two subgroups.

### Geographic distribution of genetic groups

Genetic groups recognized in two major clades of *R. tagoi* (sensu lato) and *R. sakuraii* (totally 15 subclades/groups) showed a complex pattern of geographic distribution, with sympatric or parapatric occurrence in some (Figs. 1, 3 and Table 4). Only *R. t. yakushimensis* (A-8), *R. t. okiensis* (B-1), *R. t. tagoi* from Awaji Island and Shikoku (A-7), and *Rana t. tagoi* from Kyushu (A-9a, b, and c) were allopatric from the other genetic groups, although A-9a and A-9b were parapatric within Kyushu.

*Rana t. tagoi* Group A-1a was widely distributed throughout northeastern Honshu to the northern part of central Honshu. It was transposed by *R. t. tagoi* Groups A-1b and B-2a in northeastern Kinki, the westernmost area of its distributional range. Group A-1a and A-1b were parapatric, with the exception of one sympatric site (locality 41). Group A-1b was distributed in northern part of Kinki, and was sympatric with B-2a in almost all ranges of its distribution (localities 42 to 48 and 50).

Group A-1a was transposed by *R. t. tagoi* in Subclade A-2 in northern Kanto. They were mostly parapatric, but were sympatric in one site (locality 18). *Rana t. tagoi* in Subclade A-2 was replaced by Subclade A-6 (southern Chubu) in western Kanto. Subclades A-4 and A-5 occurred in northwestern Kanto to central Chubu, between Group A-1a in the Sea of Japan side and Subclade A-6 in the Pacific side. Subclade A-4 was sympatric with A-1a, and A-5 also seemed to overlap with A-1a. Subclade A-6 widely occurred covering southern Chubu, and was replaced by Group B-2a

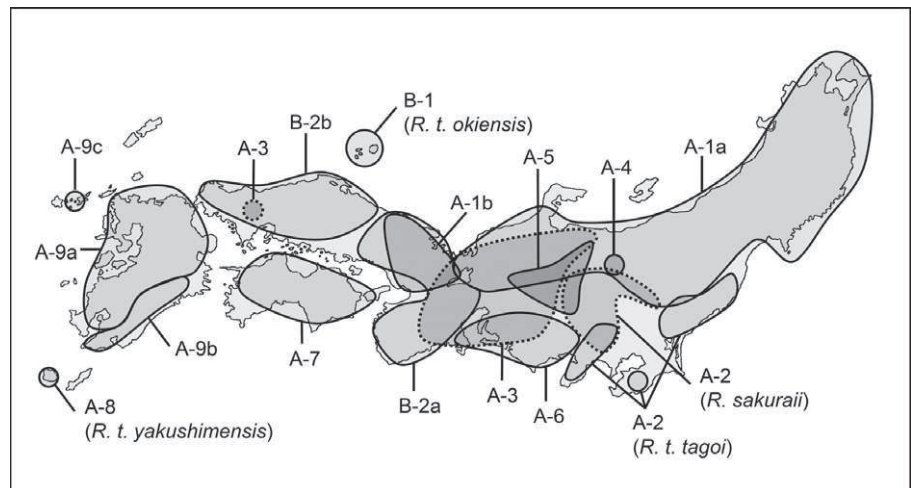

**Fig. 3.** Distributional range of each genetic group of *Rana tagoi* (solid line) and *R. sakuraii* (dotted line). For names of genetic groups, see Table 1 and Fig. 2.

in the Shima Peninsula (locality 78).

Group B-2a of *R. t. tagoi* from Kinki, which was sympatric with the *R. t. tagoi* small type (A-1b) as shown above, was transposed in the west by B-2b, which widely occurred in Chugoku, western Honshu.

*Rana sakuraii* was divided into two genetic groups, eastern (A-2) and western (A-3) subclades. In western Kanto, *R. sakuraii* was sympatric with *R. t. tagoi* and together formed Subclade A-2. Also, in the northern part of its distribution, *R. sakuraii* in Subclade A-2 was sympatric with *R. t. tagoi* A-1a (locality 20) and parapatric with A-4 (localities 160 and 67), and furthermore, seemed to overlap with A-5 in central Chubu. Subclade A-2 was transposed by *R. sakuraii* Subclade A-3 in the most western range of its distribution. Subclade A-3 largely overlapped with *R. t. tagoi* genetic groups in western Honshu (e.g., A-5, A-6, and B-2b), and sympatric with A-1a (locality 35), A-1b (locality 44), and B-2a (localities 44 and 114).

## DISCUSSION

### Phylogenetic relationships and genetic differentiation

Using allozymes and proteins, Nishioka et al. (1987) constructed a phenogram in which *R. t. yakushimensis* (A-8 in this study) was shown to be divergent from *R. t. tagoi* from western Japan. Within the latter, populations from Kinki (B-2a), Chugoku (B-2b), and Shikoku (A-7) formed one group, and those from Kyushu (A-9a) and *R. t. okiensis* (B-1) formed another. These results are completely discordant with results obtained by us or by Tanaka et al. (1996) from the mitochondrial *cyt b* gene. Our results showed common features with those reported by Tanaka et al. (1994, 1996: i.e., paraphyly of *R. tagoi*; large differentiation between large [B-2a] and small [A-1b] types of *R. t. tagoi* from Kyoto). Although there are superficial differences between Tanaka et al. (1994, 1996) and the present study, in the relationships of *R. t. tagoi*, *R. t. yakushimensis*, and *R. t. okiensis*, such discrepancies surely resulted from insufficient sampling in the Tanaka et al. (1994, 1996) study (e.g., Tanaka et al. [1996] used seven samples from five localities of *R. t. tagoi*, one sample of *R. t. yakushimensis*, three samples of *R. t. okiensis*, and six samples from three localities of *R.*

*sakuraii*), and results obtained from mtDNA analyses are considered essentially similar.

Discordance between trees based on nuclear (i.e., allozymes) and mitochondrial markers is generally explained by the paralogy of genes, introgressive hybridization, and incomplete lineage sorting with ancestral polymorphism (Ballard and Whitlock, 2004). However, these factors are difficult to differentiate without additional studies, in which nuclear marker analyses are made on the samples used in the present mtDNA analysis. In contrast to mitochondrial genes, allozymes are of limited value in estimating phylogenies, as historical relationships among alleles remain unclear (Avise, 2000). Thus, phylogenetic trees based on mitochondrial genes should be more valid than the allozymic ones, although the possibility of mitochondrial gene introgression, which leads to a strongly biased gene tree, is not precluded.

The geographic pattern of genetic differentiations obtained for *R. tagoi* is quite unique among Japanese anurans in that samples from western Honshu (Clade B) first diverge from the others (Clade A). In wide-ranging Japanese anurans (e.g., *Bufo japonicus*: Matsui, 1984; Igawa et al., 2006; *R. japonica*: Sumida and Ogata, 1998; *R. rugosa*: Sekiya et al., 2010; *Buergeria buergeri*: Nishizawa et al., 2011), populations from western Honshu and those from Shikoku and Kyushu tend to form a clade, unlike in *R. tagoi*, in which populations from eastern to central Honshu, Shikoku, and Kyushu form a clade (Clade A). This unique distribution suggests that geographical and environmental factors that separated Clades A and B of *R. tagoi* differ from those that affected the distribution of other Japanese anurans. Our results do not contradict Matsui and Matsui's (1990) hypothesis that the probable common ancestor of *R. tagoi* and *R. sakuraii* would have a habit of subterranean breeding, which is quite unique among Japanese anurans. The availability of subterranean environments, which was not so critical in other anurans, may have been a major factor that caused population fragmentation and subsequent genetic divergence in the ancestor of *R. tagoi* and *R. sakuraii*.

The current wider distribution of Clade A compared to Clade B indicates the Clade A ancestor was dominant throughout Honshu, including Kinki and Chugoku, in the past, whereas Clade B now predominates. Later, ancestral Clade B appears to have arisen somewhere in western Honshu and expanded its range towards east while affecting Clade A by exclusion through competition, and/or causing gene introgression to lose its original haplotypes. *Rana sakuraii* and the small type of *R. t. tagoi* are sympatric with, and specifically distinct from Clade B in Kinki and Chugoku. It is possible that these two groups have already sufficiently differentiated ecologically to avoid competition or introgressive hybridization with Clade B for coexistence in these regions.

### Taxonomic relationships

Of the many genetic groups recognized, Group A-1a should be considered true *R. t. tagoi* as it included the topotypic population from Kamitakara of the current Takayama-shi (locality 33), Gifu (Okada, 1928; Shibata, 1988). The small type of *R. t. tagoi*, one of the two types of *R. t. tagoi* from

Kinki (Sugahara, 1990), represented Group A-1b and was sympatric with the large type (parts of A-1a and B-2a). The small type differs from the large type in morphological, acoustic, and breeding ecological traits (Sugahara, 1990; Sugahara and Matsui, 1992, 1993, 1994, 1995, 1996, 1997). Thus, *R. t. tagoi* small type (A-1b) should be regarded as a distinct species. In contrast, *R. t. tagoi* morphologically identified as the large type was placed in two genetic groups (A-1a and B-2a), both with samples from the regions other than Kinki, and its taxonomic status is still unclear.

Subclade A-4 from one locality in Chubu has a unique breeding ecology and morphology different from sympatric Group A-1a (Misawa, private communication; Eto et al., 2012) and would be a distinct species. *Rana t. tagoi* from Neba-mura, Nagano, in Subclade A6 could also be another distinct species as it has  $2n = 28$  chromosomes in contrast to  $2n = 26$  in other *R. tagoi* and *R. sakuraii* populations (Ryuzaki et al., 2006). In our resultant tree, however, samples from Neba-mura (locality 76) were very close to and formed Subclade A6 with *R. t. tagoi* from southern Chubu and Shima Peninsula. It is thus necessary to investigate the chromosome number of the other populations in A-6 to determine taxonomic status of the Neba-mura population.

Details of morphological and ecological variations among other genetic groups of *R. t. tagoi* are generally poorly studied. Most of them are generally too similar to distinguish morphologically, but there are some exceptions. For example, representatives of Group A-1a and *R. t. tagoi* in Subclade A-2, at their range of sympatry in northern Kanto, are morphologically differentiated although slightly (Eto et al., unpublished data). Thus *R. t. tagoi* seems to include more cryptic taxa than previously suggested.

*Rana t. yakushimensis* formed Subclade A-8 by itself, and was split from the other *R. tagoi* subspecies and *R. sakuraii*. This result suggests its specific, rather than subspecific status, although it is morphologically very similar to *R. t. tagoi* (Maeda and Matsui, 1999). Supporting this idea, Nishioka et al. (1987) reported that *R. t. yakushimensis* was slightly isolated from *R. t. tagoi* from Chugoku (B-2b) by a low degree of hybrid inviability.

Another subspecies, *R. t. okiensis* also formed a distinct subclade (B-1) and split from other genetic groups. This subspecies is morphologically distinct from the other subspecies of *R. tagoi* and *R. sakuraii* (Maeda and Matsui, 1999), and there is little doubt to treat it as a distinct taxon. Conlon et al. (2010) suggested *R. t. okiensis* and *R. t. tagoi* to be heterospecific from antimicrobial peptide structure, and Nishioka et al. (1987) and Daito et al. (1998b) reported post-mating isolation of the two subspecies. These previous studies and present result strongly suggest that *R. t. okiensis* should be treated as a species distinct from *R. t. tagoi*.

The phylogenetic relationships obtained by our group, in which *R. tagoi* and *R. sakuraii* are revealed to be paraphyletic, are in disagreement with current taxonomy. This result may be partly due to imperfect taxonomy (i.e., insufficient detection of cryptic species), in addition to the evolutionary processes as mentioned above. *Rana sakuraii* was divided into two genetic groups (Subclade A-2 and A-3). Of these, Subclade A-2 includes topotypic samples and should be regarded as true *R. sakuraii*, in spite of the possibility of past gene introgression from *R. t. tagoi* as discussed above.

Although both subclades of *R. sakuraii* are sympatric with some genetic groups of *R. t. tagoi* in Honshu (Table 4), the two species are known to be reproductively isolated by differences in the season, site, and behavior of breeding (Maeda and Matsui, 1999). Moreover, *R. sakuraii* in A-2 is completely isolated from *R. t. tagoi* from Kinki (large type from Kyoto: B-2a) and *R. t. okiensis* (B-1) by postmating isolating mechanisms (Daito et al., 1998a; Daito, 1999). Because no obvious morphological and ecological differences have been detected between the two genetic groups of *R. sakuraii*, it seems safe at present to retain it as a single species.

It is now popular to regard uncorrected p-distances in 16S rRNA of 3–5% to be thresholds between intra- and inter-specific divergence levels in anurans (Vences et al., 2005; Fouquet et al., 2007). However, Hillis and Wilcox (2005) reported interspecific sequence divergences of 16S rRNA among American ranid frogs to be 1.2–18.7% (uncorrected p-distances calculated from GenBank data). Thus, sequence divergence alone is not an absolute indicator to draw taxonomic conclusions, though it can be considered useful in detecting candidate species. As to ND1, Vredenburg et al. (2007) separated *R. sierrae* and *R. muscosa*, with 4.6% sequence divergence in ND1 and ND2, as distinct species.

In the light of these reports, divergences among genetic groups of *R. tagoi* and *R. sakuraii* (1.3–3.5% in 16S rRNA and 2.9–7.0% in ND1) are generally not very large. Of the cryptic lineages discussed above, A-1b (small type) could be regarded as heterospecific with B-2a (large type: divergences of 3.2% in 16S rRNA and 6.7% in ND1), although its divergence from true *R. t. tagoi* (A-1a) is not large enough to indicate specific separation (1.3% and 4.1%). Of other unique groups observed, Subclade A6, including a population with extra number of chromosomes, differed from the other groups by divergences of 1.5–3.3% (16S rRNA) and 3.4–6.7% (ND1). Likewise, divergences were 1.8–3.3% and 4.1–6.4% between *R. t. okiensis* and the other groups, and 1.5–2.8% and 2.8–6.9% between *R. t. yakushimensis* and the other groups. These values partly exceed proposed thresholds or reported values for specific separation (Fouquet et al., 2007; Vredenburg et al., 2007). Other combinations produced even smaller divergences (1.4% and 3.9% between Subclade A-4 and Group A-1a; 1.7% and 4.0% between Group A-1a and *R. t. tagoi* in Subclade A-2; and 1.1% and 2.1% between *R. sakuraii* and *R. t. tagoi* in A-2), in spite of their sympatric occurrences, and posed questions about the universality of threshold values in DNA barcoding.

In frogs, sister species sometimes exhibit very small sequence divergences in spite of their distinct morphological and/or ecological differences (e.g., Matsui et al., 2006), and similar situations appear to apply to unique genetic groups recognized in *R. tagoi* and *R. sakuraii*. Small sequence divergences, like morphological and ecological similarities, suggest relatively recent separation among genetic groups of these frogs.

This study provided a large amount of new information about the complex genetic diversity and consequential taxonomic problems with respect to *R. tagoi* and *R. sakuraii*. However, mtDNA alone is not a conclusive indicator of

reproductive isolation, due to its maternal mode of inheritance. Further studies, including nuclear marker analyses, are necessary to clarify reproductive isolations among genetic groups and draw definitive taxonomic conclusions.

## ACKNOWLEDGMENTS

We thank G. Aoki, K. Araya, H. Fujita, M. Hayashi, A. Hamidy, T. Hikida, S. Ikeda, K. Kasugai, M. Kato, K. Kawauchi, J. B. Kim, N. Koike, Y. Kokuryo, M. Kumagai, N. Kuraishi, N. Maeda, M. Matsui, Mt. Matsui, T. Matsuki, T. Matsuo, Y. Misawa, K. Mitsui, Y. Miyagata, Y. Mizuno, A. Mori, S. Mori, N. Nakahama, T. Nakano, K. Nishikawa, H. Okawa, S. Okada, J. Oki, M. Sakamoto, T. Sasaoka, Y. Sasaoka, T. Seto, T. Shimada, Z. Shimizu, R. Shimoyama, T. Sota, T. Sueyoshi, K. Sugahara, T. Sugihara, H. Takeuchi, S. Tanabe, Y. Tatewaki, H. Tokunaga, N. Tokuyama, A. Tominaga, T. Utsunomiya, Y. Utsunomiya, M. Yamagami, N. Yoshikawa, and M. Yumoto for help in collecting specimens and N. Kuraishi and N. Yoshikawa for assisting with experiments. We are also grateful to H. Ota and an anonymous reviewer for valuable comments on the manuscript. This work was partially supported by grants from The Monbukagakusho through the Japanese Society for the Promotion of Sciences (JSPS: 15370038, 20405013) to MM.

## REFERENCES

- Avice JC (2000) *Phylogeography: The History and Formation of Species*. Harvard University Press, Cambridge, Massachusetts
- Ballard JWO, Whitlock MC (2004) The incomplete natural history of mitochondria. *Mol Ecol* 13: 729–744
- Boulenger GA (1920) A monograph of the South Asian, Papuan, Melanesian, and Australian frogs of the genus *Rana*. *Rec Ind Mus* 20: 1–126
- Castresana J (2000) Selection of conserved blocks from multiple alignments for their use in phylogenetic analysis. *Mol Biol Evol* 17: 540–552
- Conlon JM, Coquet L, Jouenne T, Leprince J, Vaudry H, Iwamuro S (2010) Evidence from the primary structures of dermal antimicrobial peptides that *Rana tagoi okiensis* and *Rana tagoi tagoi* (Ranidae) are not conspecific subspecies. *Toxicon* 55: 430–435
- Daito Y (1999) Development of postmating isolation in the Tago's brown frog group. III. Offspring between Oki population, Tago's brown frog of Oki island ♀ and Stream brown frog ♂. *Amph Hist* 2: 23–29 (in Japanese)
- Daito Y, Yokota T, Inoue K, Nakata T (1998a) Development of postmating isolation in the Tago's brown frogs (*Rana*) I. Offspring between *Rana sakuraii* and *Rana tagoi tagoi*, Kurama population. *Bull Fac Hum Devel Kobe Univ* 5: 507–522 (in Japanese)
- Daito Y, Hiramoto M, Yoshimoto Y (1998b) Development of postmating isolation in the Tago's brown frogs (*Rana*) II. Offspring between *Rana tagoi tagoi* and Oki population, Tago's brown frog of Oki Isl. *Bull Fac Hum Devel Kobe Univ* 5: 523–530 (in Japanese)
- Dubois A (1992) Notes sur la classification des Ranidae (Amphibiens Anoures). *Bull Mens Soc Linn Lyon* 61: 305–352
- Eto K, Matsui M, Misawa Y (2012) On two types of *Rana tagoi tagoi* from the former Kuni-mura, Gunma Prefecture. *Bull Herpetol Soc Japan* 2012: 81 (in Japanese)
- Felsenstein J (1985) Confidence limits on phylogenies: an approach using the bootstrap. *Evolution* 39: 783–791
- Fouquet A, Gilles A, Vences M, Marty C, Blanc M, Gemmill NJ (2007) Underestimation of species richness in Neotropical frogs revealed by mtDNA analyses. *PLoS ONE* 2: e1109
- Frost DR (1985) *Amphibian Species of the World: A Taxonomic and Geographical Reference*. Allen Press, Lawrence
- Frost DR, Grant T, Faivovich JN, Bain RH, Haas A, Haddad CFB, et al. (2006) The amphibian tree of life. *Bull Amer Mus Nat Hist* 297: 1–370

- Hedges SB (1994) Molecular evidence for the origin of birds. *Proc Nat Acad Sci USA* 91: 2621–2624
- Hillis DM, Wilcox TP (2005) Phylogeny of the New World true frogs (*Rana*). *Mol Phylogenet Evol* 34: 299–314
- Hillis DM, Mable BK, Larson A, Davis SK, Zimmer EA (1996) Nucleic acids IV: sequencing and cloning. In "Molecular Systematics" Ed by DM Hillis, BK Mable, C Moritz, Sinauer Associates, Sunderland, pp 321–378
- Huelsenbeck JP, Hillis DM (1993) Success of phylogenetic methods in the four–taxon case. *Syst Biol* 42: 247–264
- Huelsenbeck JP, Ronquist FR (2001) MrBayes: Bayesian inference of phylogenetic trees. *Bioinformatics* 17: 754–755
- Igawa T, Kurabayashi A, Nishioka M, Sumida M (2006) Molecular phylogenetic relationships of toads distributed in the Far East and Europe inferred from the nucleotide sequences of mitochondrial DNA genes. *Mol Phylogenet Evol* 38: 250–260
- Jobb G (2008) TREEFINDER version of October 2008. Munich, Germany. Distributed by the author at [www.treefinder.de](http://www.treefinder.de)
- Leaché AD, Reeder TW (2002) Molecular systematics of the eastern fence lizard (*Sceloporus undulatus*): a comparison of parsimony, likelihood, and Bayesian approaches. *Syst Biol* 51: 44–68
- Maeda N, Matsui M (1999) Frogs and Toads of Japan, Revised Edition. Bun-ichi Sogo Shuppan, Tokyo (in Japanese)
- Matsui M (1984) Morphometric variation analyses and revision of the Japanese toads (genus *Bufo*, Bufonidae). *Contrib Biol Lab Kyoto Univ* 26: 209–428
- Matsui T, Matsui M (1990) A new brown frog (genus *Rana*) from Honshu, Japan. *Herpetologica* 46: 78–85
- Matsui M, Shimada T, Liu WZ, Maryati M, Khonsue W, Orlov N (2006) Phylogenetic relationships of Oriental torrent frogs in the genus *Amolops* and its allies (Amphibia, Anura, Ranidae). *Mol Phylogenet Evol* 38: 659–666
- Mueller RL (2006) Evolutionary rates, divergence dates, and the performance of mitochondrial genes in Bayesian phylogenetic analysis *Syst Biol* 55: 289–300
- Nishikawa K, Matsui M, Tanabe S, Sato S (2007) Morphological and allozymic variation in *Hynobius boulengeri* and *Hynobius stejnegeri* (Amphibia: Urodela: Hynobiidae). *Zool Sci* 24: 752–766
- Nishioka M, Ohta S, Sumida M (1987) Intraspecific differentiation of *Rana tagoi* elucidated by electrophoretic analysis of enzymes and blood proteins. *Sci Rep Lab Amphib Biol Hiroshima Univ* 9: 97–133
- Nishizawa T, Kurabayashi A, Kunihara T, Sano N, Fujii T, Sumida M (2011) Mitochondrial DNA diversification, molecular phylogeny, and biogeography of the primitive rhacophorid genus *Buergeria* in East Asia. *Mol Phylogenet Evol* 59: 139–147
- Nöllert A, Nöllert C (1992) Die Amphibien Europas. Franckh-Kosmos, Stuttgart
- Okada Y (1928) Notes on Japanese frogs. *Annot Zool Jap* 11: 269–277
- Rambaut A, Drummond AJ (2007) Tracer version 1.4. Available at <http://tree.bio.ed.ac.uk/software/tracer>
- Ryuzaki M, Nishioka M, Kawamura T (2006) Karyotypes of *Rana tagoi* Okada with diploid number 28 in the Chausu Mountains of the Minamishinshu district of Nagano Prefecture, Japan (Anura:Ranidae). *Cytogenet Genome Res* 114: 56–65
- Sekiya K, Ohtani H, Ogata M, Miura I (2010) Phyletic diversity in the frog *Rana rugosa* (Anura: Ranidae) with special reference to a unique morphotype found from Sado island, Japan. *Curr Herpetol* 29: 69–78
- Shibata Y (1988) The type localities of three subspecies of a Japanese brown frog, *Rana tagoi* OKADA (Amphibia: Ranidae). *Bull Osaka Mus Nat Hist* 43: 43–46 (in Japanese)
- Shimada T, Matsui M, Yambun P, Sudin A (2011) A taxonomic study of Whitehead's torrent frog, *Meristogenys whiteheadi*, with descriptions of two new species (Amphibia: Ranidae). *Zool J Linn Soc* 161: 157–183
- Sugahara T (1990) Reproductive ecology of *Rana tagoi tagoi* at Kitayama in Kyoto. *Jpn J Herpetol* 13: 145 (in Japanese)
- Sugahara T, Matsui M (1992) Larval growth and development in two types of the Japanese brown frog, *Rana tagoi tagoi*, at Kumogahata, Kyoto. *Jpn J Herpetol* 14: 209 (in Japanese)
- Sugahara T, Matsui M (1993) Morphometric comparisons in two types of *Rana t. tagoi* from Kumogahata, Kyoto. *Jpn J Herpetol* 15: 83 (in Japanese)
- Sugahara T, Matsui M (1994) An investigation of characters that discriminate two morphotypes of *Rana tagoi tagoi*. *Jpn J Herpetol* 15: 151 (in Japanese)
- Sugahara T, Matsui M (1995) Acoustic comparisons in two types of *Rana t. tagoi* from Kumogahata, Kyoto. *Jpn J Herpetol* 16: 64–65 (in Japanese)
- Sugahara T, Matsui M (1996) Morphological variation in *Rana tagoi* from regions around Kinki. *Jpn J Herpetol* 16: 151–152
- Sugahara T, Matsui M (1997) Breeding seasons and sites in two types of *Rana tagoi tagoi* from Kumogahata, Kyoto. *Jpn J Herpetol* 17: 68–69 (in Japanese)
- Sumida M, Ogata M (1998) Intraspecific differentiation of the Japanese brown frog *Rana japonica* inferred from mitochondrial DNA sequences of the cytochrome b gene. *Zool Sci* 15: 989–1000
- Swofford DL (2002) PAUP\*. Phylogenetic Analysis Using Parsimony (\*and Other Methods), Version 4. Sinauer Associates, Sunderland
- Tanabe AS (2008) Phylogears version 1.5.2010.03.24. Software distributed by the author at <http://www.fifthdimension.jp/>
- Tanabe AS (2010) Kakusan4 version 0.1. Software distributed by the author at <http://www.fifthdimension.jp/>
- Tanaka T, Matsui M, Takenaka O (1994) Estimation of phylogenetic relationships among Japanese brown frogs from mitochondrial cytochrome b gene (Amphibia: Anura). *Zool Sci* 11: 753–757
- Tanaka T, Matsui M, Takenaka O (1996) Phylogenetic relationships of Japanese brown frogs (*Rana*: Ranidae) assessed by mitochondrial cytochrome b gene sequences. *Biochem Syst Ecol* 24: 299–307
- Tanaka-Ueno T, Matsui M, Chen S-L, Takenaka O, Ota H (1998) Phylogenetic relationships of brown frogs from Taiwan and Japan assessed by mitochondrial cytochrome b gene sequences (*Rana*: Ranidae). *Zool Sci* 15: 283–288
- Thompson JD, Higgins DG, Gibson TJ (1994) CLUSTAL W: improvement the sensitivity of progressive multiple sequence alignment through sequence weighting, position-specific gap penalties and weight matrix choice. *Nucleic Acids Res* 22: 4673–4680
- Vences M, Thomas M, Bonett RM, Vieites DR (2005) Deciphering amphibian diversity through DNA barcoding: chances and challenges. *Phil Trans R Soc B* 360: 1859–1868
- Vredenburg VT, Bingham R, Knapp R, Morgan JAT, Moritz C, Wake D (2007) Concordant molecular and phenotypic data delineate new taxonomy and conservation priorities for the endangered mountain yellow-legged frog. *J Zool* 271: 361–374
- Wilkinson JA, Drewes RC, Tatum OL (2002) A molecular phylogenetic analysis of the family Rhacophoridae with an emphasis on the Asian and African genera. *Mol Phylogenet Evol* 24: 265–273
- Yoshikawa N, Matsui M, Nishikawa K, Kim JB, Kryukov A (2008) Phylogenetic relationships and biogeography of the Japanese clawed salamander, *Onychodactylus japonicus* (Amphibia: Caudata: Hynobiidae), and its congener inferred from the mitochondrial cytochrome b gene. *Mol Phylogenet Evol* 49: 249–259

## Notes on a Rare Bornean Bufonid *Ansonia latidisca* Inger, 1966, with Special Reference to Its Phylogenetic Position

MASAFUMI MATSUI<sup>1\*</sup>, KANTO NISHIKAWA<sup>1</sup>,  
SIEW TECK YEO<sup>2</sup>, AND KOSHIRO ETO<sup>1</sup>

<sup>1</sup> Graduate School of Human and Environmental Studies, Kyoto University, Kyoto 606–8501, JAPAN

<sup>2</sup> Cat City Holidays Sdn. Bhd., Suite 59.1, First floor, Kueh Hock Kui Commercial Centre, Jalan Tun Ahmad Zaidi Adruce, Kuching 93150, Sarawak, MALAYSIA

**Abstract:** On the basis of three female specimens collected recently, some aspects of a little known Bornean bufonid, *Ansonia latidisca*, are reported. On the mitochondrial phylogenetic tree, the species is basal to the group consisting of some Bornean species, and most Peninsular Malaysian and Thailand species, which is sister to the other group consisting of the remaining Bornean species, several Philippine species, and one Peninsular species. This relationship indicates that the the genus *Ansonia* has originated within Borneo. Superficial similarity of the species with *Sabahphrynus maculatus* is thought to be the result of convergence in adaptation to an arboreal life.

Key words: *Ansonia*; Borneo; Phylogeny; Rare species; *Sabahphrynus*

### INTRODUCTION

Oriental stream toads of the genus *Ansonia* Stoliczka, 1870 are famous for their unique larvae that adhere to rocks in fast-flowing, high gradient streams by a large oral sucker (Inger, 1966; Matsui et al., 2005). The genus encompasses about 26 described species (Frost, 2011; Wilkinson et al., 2012), with several additional taxa still requiring formal descriptions (Matsui et al., 2010). Among already named congeners, *A. latidisca* Inger, 1966 from the western part of Borneo is one of the least known species.

The species was described based on the male

holotype (RMNH [Rijksmuseum van Natuurlijke Historie=The National Museum of Natural History “Naturalis” in Leiden] 10677) from top of Mount Damus, Sambas, Kalimantan, Indonesian Borneo, by J. G. Hallier (Inger, 1966; Gassó Miracle et al., 2007) and a female paratype (BMNH [British Museum of Natural History]=NHM [Natural History Museum], London 99.12.8.12) from Mount Penrissen, First Division (now Kuching Division), Sarawak, Malaysian Borneo (Inger, 1966).

The holotype seems to have been collected in 1893 (Fig. 1, see discussion), and from its catalogue number, the paratype should have been collected before 1899, both more than 100 years ago. Another specimen (NHM, London 1973.528 [Indraneil Das, personal communication on 10 September 2012]) is said to have been collected in 1924 (Conservation

---

\* Corresponding author. Tel/Fax: +81-75-753-6846;  
E-mail address: fumi@zoo.zool.kyoto-u.ac.jp



FIG. 1. The male holotype of *Ansonia latidisca* (RMNH 10677) deposited in The National Museum of Natural History "Naturalis" in Leiden.

International, 2011), but further detailed data are not available to us at present. Because the habitats at least in Sarawak have been seriously modified, there has been serious concern about the extinction of the species there. For example, *A. latidisca* has been listed as Endangered B1ab(iii) + 2ab(iii) by IUCN (Stuart et al., 2008). However, in the course of the "Global Search for Lost Amphibians" by IUCN, the species was finally rediscovered in 2011 on Mount Penrissen, Sarawak (Conservation International, 2011). We also made a survey there twice recently and were able to find the species ourselves.

From examination of the holotype in the Rijksmuseum (Matsui, unpublished observations) and from description in the literature, we had the impression that the species superficially resembles *Sabahphrynus maculatus* (Mocquard, 1890) from Sabah, Malaysian Borneo (Matsui et al., 2007), and have been

interested in elucidating the phylogenetic position of *A. latidisca* among *Ansonia* and allied genera. We therefore studied the specimens obtained by analyzing mitochondrial gene sequences, based on the relationships of most members of the genus *Ansonia* that have already been clarified (Matsui et al., 2010).

#### MATERIALS AND METHODS

Fieldwork was conducted in September 2010 and February to March 2012 on Gunung (=Mt.) Penrissen, Padawan, western Sarawak. Specimens are deposited in the Sarawak Research Collections (SRC) and the Graduate School of Human and Environmental Studies, Kyoto University (KUHE).

The following 25 body measurements were taken to the nearest 0.1 mm with dial calipers, following Matsui (1984) and Matsui (1994): (1) snout-vent length (SVL); (2) head length (HL); (3) snout length (SL); (4) nostril-eyelid length (N-EL); (5) eye length (EL); (6) eye diameter (ED), diameter of the exposed portion of the eyeball; (7) tympanum-eye length (T-EL); (8) tympanum diameter (TD); (9) head width (HW); (10) internarial distance (IND); (11) interorbital distance (IOD); (12) upper eyelid width (UEW); (13) forelimb length (FLL); (14) lower arm and hand length (LAL); (15) hand length (HAL); (16) inner palmar tubercle length (IPTL); (17) outer palmar tubercle length (OPTL); (18) hindlimb length (HLL); (19) thigh length (THIGH); (20) tibia length (TL); (21) foot length (FL); (22) inner metatarsal tubercle length (IMTL); (23) outer metatarsal tubercle length (OMTL); (24) third finger disk diameter (3FDW); and (25) fourth toe disk diameter (4TDW). For morphological comparisons, we also examined specimens of *Sabahphrynus maculatus* deposited in the KUHE.

We examined DNA sequences of 12S and 16S rRNA genes and the intervening tRNA gene for valine from 25 specimens of 23 named species (including three individuals of *A. latidisca*) of the genus *Ansonia*. We also examined the sequences of representatives of



five other Southeast Asian bufonid genera (*Sabahphrynus* Matsui, Yambun, and Sudin, 2007; *Pedostibes* Günther, 1876; *Pelophryne* Barbour, 1938; *Leptophryne* Fitzinger, 1843; and *Bufo* Laurenti, 1768 [sensu lato]), and two

distinctly distant (Frost et al., 2006) outgroup species (a bufonid, *Atelopus flavescens* Duméril and Bibron, 1841 and a dendrobatid *Dendrobates auratus* [Girard, 1855]: Table 1).

Methods for phylogenetic analyses follow

TABLE 1. Samples used for mtDNA analysis in this study together with information on species identification, locality, GenBank accession numbers, and references. KUHE=Graduate School of Human and Environmental Studies, Kyoto University.

| Species                                                     | Locality                               | Data Bank |                            |
|-------------------------------------------------------------|----------------------------------------|-----------|----------------------------|
|                                                             |                                        | Acc. No.  | Reference                  |
| <i>Ansonia kraensis</i>                                     | Thailand, Ranong                       | AB435251  | Matsui et al. (2010)       |
| <i>Ansonia inthanon</i>                                     | Thailand, Doi Inthanon                 | AB435253  | Matsui et al. (2010)       |
| <i>Ansonia siamensis</i>                                    | Thailand, Khaochong                    | AB435256  | Matsui et al. (2010)       |
| <i>Ansonia endauensis</i>                                   | West Malaysia, Johor, Endau-Rompin     | AB435257  | Matsui et al. (2010)       |
| <i>Ansonia tiomanica</i>                                    | West Malaysia, Pahang, Tioman          | AB435259  | Matsui et al. (2010)       |
| <i>Ansonia latirostra</i>                                   | West Malaysia, Pahang                  | AB435260  | Matsui et al. (2010)       |
| <i>Ansonia penangensis</i>                                  | West Malaysia, Penang                  | AB435262  | Matsui et al. (2010)       |
| <i>Ansonia malayana</i>                                     | West Malaysia, Larut                   | AB331712  | Matsui et al. (2010)       |
| <i>Ansonia jeetskumarani</i>                                | West Malaysia, Pahang                  | AB435265  | Matsui et al. (2010)       |
| <i>Ansonia platysoma</i>                                    | East Malaysia, Sabah, Bundu Tuhan      | AB435270  | Matsui et al. (2010)       |
| <i>Ansonia hanitschi</i>                                    | East Malaysia, Sabah, Kinabalu         | AB435277  | Matsui et al. (2010)       |
| <i>Ansonia spinulifer</i>                                   | East Malaysia, Sarawak, Kuching        | AB435289  | Matsui et al. (2010)       |
| <i>Ansonia minuta</i>                                       | East Malaysia, Sarawak, Kuching        | AB435281  | Matsui et al. (2010)       |
| <i>Ansonia latidisca</i>                                    | East Malaysia, Sarawak, Penrissen      | AB746459  | KUHE 55421                 |
| <i>Ansonia latidisca</i>                                    | East Malaysia, Sarawak, Penrissen      | AB746460  | KUHE 55422                 |
| <i>Ansonia latidisca</i>                                    | East Malaysia, Sarawak, Penrissen      | AB746461  | KUHE 55423                 |
| <i>Ansonia longidigita</i>                                  | East Malaysia, Sabah, Crocker          | AB331711  | Matsui et al. (2010)       |
| <i>Ansonia torrentis</i>                                    | East Malaysia, Sarawak, Gn. Mulu       | AB435296  | Matsui et al. (2010)       |
| <i>Ansonia leptopus</i>                                     | East Malaysia, Sarawak, Kuching        | AB746457  | KUHE 53839                 |
| <i>Ansonia latiffi</i>                                      | West Malaysia, Pahang                  | AB435299  | Matsui et al. (2010)       |
| <i>Ansonia albomaculata</i>                                 | East Malaysia, Sarawak, Lanjak Entimau | AB435304  | Matsui et al. (2010)       |
| <i>Ansonia guibei</i>                                       | East Malaysia, Sabah, Kinabalu         | AB435306  | Matsui et al. (2010)       |
| <i>Ansonia fuliginea</i>                                    | East Malaysia, Sabah, Kinabalu         | AB435308  | Matsui et al. (2010)       |
| <i>Ansonia muelleri</i>                                     | Philippines, Mindanao, Davao City      | AB435310  | Matsui et al. (2010)       |
| <i>Ansonia mcgregori</i>                                    | Philippines, Mindanao                  | AB435316  | Matsui et al. (2010)       |
| <i>Sabahphrynus maculatus</i><br>(= <i>Ansonia anotis</i> ) | East Malaysia, Sabah, Kinabalu         | AB331708  | Matsui et al. (2010)       |
| <i>Sabahphrynus maculatus</i>                               | East Malaysia, Sabah, Crocker          | AB331718  | Matsui et al. (2010)       |
| <i>Pelophryne signata</i>                                   | East Malaysia, Sarawak, Kuching        | AB746456  | KUHE 53200                 |
| <i>Bufo</i> ( <i>Ingerophryne</i> ) <i>parvus</i>           | West Malaysia, Penang                  | AB746455  | KUHE 39047                 |
| <i>Leptophryne borbonica</i>                                | East Malaysia, Sarawak, Penrissen      | AB746458  | KUHE 53887                 |
| <i>Bufo</i> ( <i>Duttaphrymus</i> ) <i>melanostictus</i>    | East Malaysia, Sarawak, Marudi         | AB331714  | Matsui et al. (2007)       |
| <i>Pedostibes hosii</i>                                     | East Malaysia, Sabah, Tawau            | AB331717  | Matsui et al. (2010)       |
| <i>Bufo</i> ( <i>Phrynoides</i> ) <i>asper</i>              | West Malaysia, Penang                  | AB746454  | KUHE 39025                 |
| <i>Atelopus flavescens</i>                                  | French Guiana                          | DQ283259  | Frost et al. (2006)        |
| <i>Dendrobates auratus</i>                                  | —                                      | AY326030  | Darst and Cannatella, 2004 |

Matsui et al. (2010). The PCR cycling, precipitation, and sequencing procedures were identical to those described by Matsui et al. (2010). The resultant sequences were deposited in GenBank (AB746459–746461: Table 1). The alignment matrix with 2462 nucleotide sites (942 sites for 12S rRNA; 72 for tRNA<sub>val</sub>; 1448 for 16S rRNA) was subjected to estimation of phylogenetic relationships using maximum likelihood (ML) and Bayesian inference (BI). In the BI analysis, two independent runs of four Markov chains were conducted for ten million generations, and the first three million generations were discarded as burn-in. Pairwise comparisons of uncorrected sequence divergences (p-distances) were also calculated for 16S rRNA. Details for these procedures are given in Matsui et al. (2010).

## RESULTS

### *Natural History and morphology*

We were only able to find three specimens of *A. latidisca* on one rainy night in late February. They were found in a narrow area in primary forest, on the slope surrounding a huge rocky mound (Fig. 2). A very slowly



FIG. 2. Natural habitat of *Ansonia latidisca* on Gunung Penrissen.



FIG. 3. *Ansonia latidisca* in life.

flowing headwater of a small stream, about 10 m away from the rock, was the nearest water body. Two individuals were on a leaf and the trunk, respectively, of huge trees (Fig. 3), and the remaining one was on a huge rock, all 1.5–2 m above ground. We could not hear any calls assignable to this species or find larvae in the water. Frog species observed immediately near the habitat were *Pelophryne* sp., *Limnonectes palavanensis* (Boulenger, 1894), *Limnonectes kuhlii* (Tschudi, 1838), and *Philautus refugii* Inger and Stuebing, 1996. A congeneric species *A. minuta* Inger, 1960 was found far down from there where the stream was flowing rapidly.

The three specimens obtained were all females. Two larger individuals (59.8 and 55.5 mm in SVL, Table 2) possessed small ovaries with creamy immature eggs, suggesting their non-breeding condition. The smallest female (52.1 mm in SVL) had more transparent ovaries and thus was thought to be immature. They are nearly uniform in body shape and coloration (Fig. 4), agreeing well with the diagnosis given in the original description of *A. latidisca* by Inger (1966): “a large species, females about 55 mm; tympanum visible externally; tips of fingers dilated into truncate disks (Fig. 5), that of third as wide as tympanum; tip of first finger not reaching disk of second; two rows of interorbital, conical tubercles; and no tarsal ridge”. Inger’s (1966) original description very well illustrates characteristics of the species and there is little to add:

Habitus slender; head, length (27.1–28.8% SVL) subequal to width (27.1–28.6% SVL); snout truncate, constricted before eyes, almost vertical in profile, projecting beyond lower jaw; eye small, subequal (10.0–11.0% SVL) to snout (9.8–10.8% SVL); canthus rostralis sharp, straight; lore vertical, weakly concave; nostril above symphysis, closer to tip of snout than to eye; interorbital distance (7.4–8.6% SVL) subequal to width of upper eyelid (7.7–7.9% SVL); the latter larger than width of internarial distance (6.3–7.0% SVL); pineal spot absent; tympanum distinct (4.6–5.6% SVL), about half diameter of eye; upper jaw

edentate; tongue oval, without papillae.

Forelimb extremely long (78.3–86.8% SVL) and slender; fingers slender, long, with distinct web basally, web reaching subarticular tubercles of first two fingers; first finger short, not reaching base of disk of second; fourth finger longer than second; tips of three outer fingers dilated into truncate disks about twice width of basal phalanges; disk of third finger slightly narrower (4.0–5.0% SVL) than tympanum; a large, round palmar tubercle laterally (4.3–5.0% SVL) larger than outer (3.0–3.8% SVL); subarticular tubercles feebly distinct.

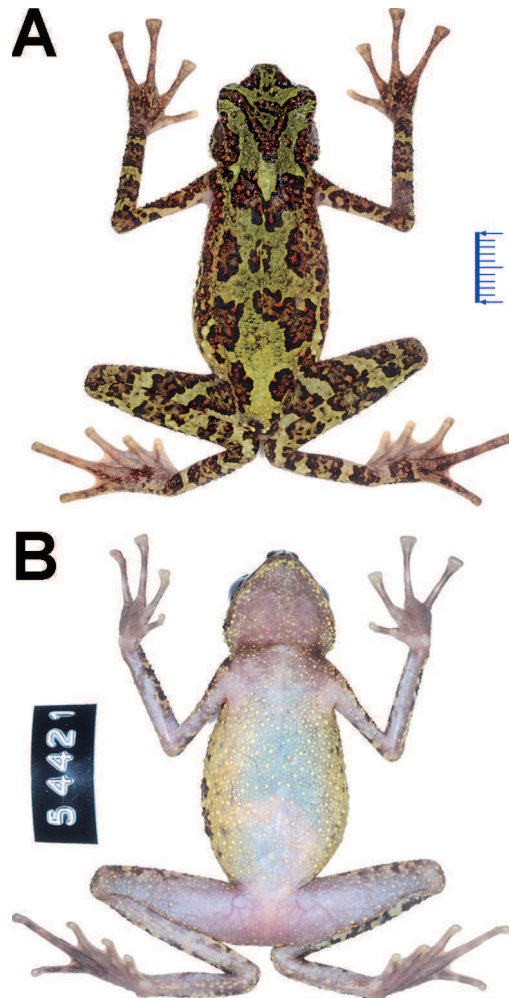

FIG. 4. Dorsal (A) and ventral (B) views, of *Ansonia latidisca*. Scale bar=10 mm.



FIG. 5. Ventral views of right hand (A) and foot (B) of *Ansonia latidisca*. Scale bar=10 mm.

Hindlimb moderately long (139.8–160.1% SVL) less than times length of forelimb; tibia moderate (44.1–50.7% SVL), heels overlapping when limbs are held at right angles to body; tibiotarsal articulation of adpressed limb reaching to point between rear angle and center of eye, or between eye and nostril; foot (37.5–41.7% SVL) shorter than tibia; tips of toes swollen but not forming truncate disks,

much narrower than tips of fingers (disk diameter of fourth toe 2.5–2.8% SVL); third toe shorter than fifth; webs between toes moderately developed (Fig. 4), formula: **I** 0–2 **II** 1–3 **III** 2–3 **IV** 3–2 **V**; subarticular tubercles obscure; inner metatarsal tubercle oval, length (4.8–5.0% SVL) shorter than first toe; outer metatarsal tubercle round, smaller (2.3–2.7% SVL) than inner one; no tarsal ridge.

Skin texture is slightly variable, but fits well with Inger's (1966) description. Inger (1966) noted that the color in alcohol of the holotype was light brown with numerous, irregular reddish brown spots dorsally and laterally; and ventrally, brown with scattered, small yellowish spots posteriorly. He also stated that the ventral color of the paratype was lighter (a brownish yellow or cream-color) than that of the holotype. Specimens in life were light greenish brown with irregular, large brown markings and scattered reddish brown spots dorsally and laterally. Ventrally, they were light brown on throat and cream with scattered, small yellowish spots posteriorly (Fig. 4).

#### Phylogeny

Of 2462 nucleotides generated, 1033 were variable, and 763 were parsimony-informative. The best substitution model for ML and

TABLE 2. Measurements (in mm, followed by percentage ratios to SVL) of three females of *Ansonia latidisca*. For abbreviations, see text. \*now deposited at SRC.

| KUHE | 54422       | 54421       | 54423*      | KUHE  | 54422        | 54421        | 54423*       |
|------|-------------|-------------|-------------|-------|--------------|--------------|--------------|
| SVL  | 59.8        | 55.5        | 52.1        |       |              |              |              |
| HL   | 16.2 (27.1) | 16.0 (28.8) | 14.6 (28.0) | LAL   | 33.8 (56.5)  | 34.6 (62.3)  | 32.6 (62.6)  |
| SL   | 5.4 (9.0)   | 6.0 (10.8)  | 5.2 (10.0)  | HAL   | 17.0 (28.4)  | 16.7 (30.1)  | 16.4 (31.5)  |
| N-EL | 3.5 (5.9)   | 3.4 (6.1)   | 3.4 (6.5)   | IPTL  | 2.6 (4.3)    | 2.8 (5.0)    | 2.5 (4.8)    |
| EL   | 6.2 (10.4)  | 6.1 (11.0)  | 5.2 (10.0)  | OPTL  | 2.3 (3.8)    | 2.1 (3.0)    | 2.0 (3.8)    |
| ED   | 5.2 (8.7)   | 5.1 (9.2)   | 4.4 (8.4)   | HLL   | 83.6 (139.8) | 88.1 (158.7) | 83.4 (160.1) |
| T-EL | 0.5 (0.8)   | 0.8 (1.4)   | 0.5 (1.0)   | THIGH | 25.7 (43.0)  | 26.8 (48.2)  | 25.1 (48.2)  |
| TD   | 3.0 (5.0)   | 3.1 (5.6)   | 2.4 (4.6)   | TL    | 26.4 (44.1)  | 27.5 (49.5)  | 26.4 (50.7)  |
| HW   | 16.2 (27.1) | 15.9 (28.6) | 14.4 (27.6) | FL    | 22.4 (37.5)  | 23.1 (41.6)  | 21.7 (41.7)  |
| IND  | 4.2 (7.0)   | 3.6 (6.5)   | 3.3 (6.3)   | IMTL  | 2.9 (4.8)    | 2.7 (4.9)    | 2.6 (5.0)    |
| IOD  | 4.4 (7.4)   | 4.7 (8.5)   | 4.5 (8.6)   | OMTL  | 1.4 (2.3)    | 1.5 (2.7)    | 1.3 (2.5)    |
| UEW  | 4.6 (7.7)   | 4.3 (7.7)   | 4.1 (7.9)   | 3FDW  | 3.0 (5.0)    | 2.5 (4.5)    | 2.1 (4.0)    |
| FLL  | 46.8 (78.3) | 46.3 (83.4) | 45.2 (86.8) | 4TDW  | 1.7 (2.8)    | 1.4 (2.5)    | 1.4 (2.7)    |

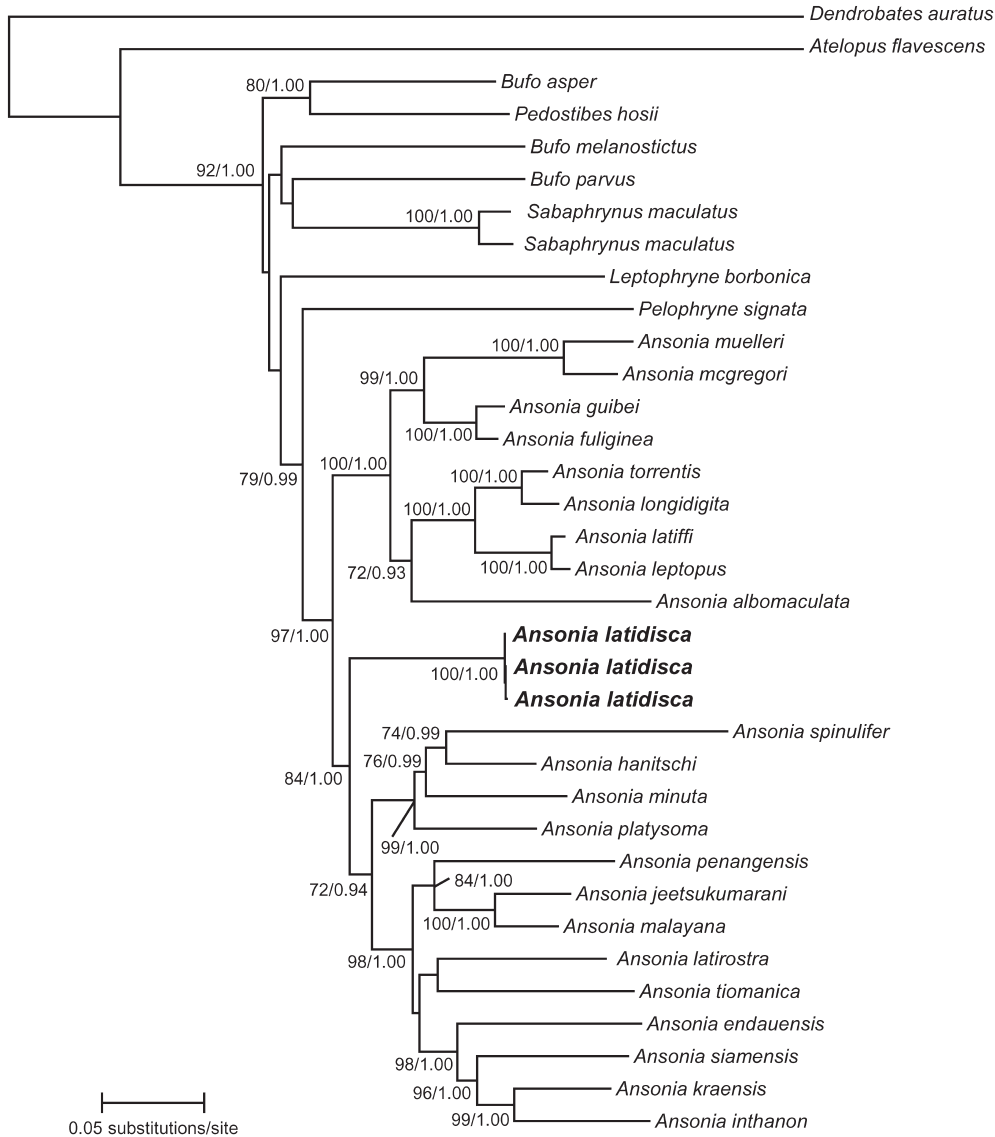

FIG. 6. ML tree from a 2462 bp sequence of mitochondrial 12S rRNA, tRNA<sup>Val</sup> and 16S rRNA genes for samples of *Ansonia* and related species. Numbers above or below branches represent bootstrap supports for ML inferences and Bayesian posterior probabilities (ML-BS/BPP).

Bayesian inference derived from Kakusan4 (Tanabe, 2011) was a general time-reversible model with a gamma shape parameter (estimated gamma values for each analysis were 0.241 and 0.243, respectively). The likelihood value of the ML and Bayesian trees were lnL -22644.606 and -22682.499, respectively.

Phylogenetic analyses employing two differ-

ent optimality criteria yielded very slightly different topologies, and only the ML tree is presented in Fig. 6. Monophyly of Southeast Asian bufonid taxa (*Bufo* [sensu lato], *Leptophryne*, *Pelophryne*, *Pedostibes*, *Sabaphryne*, and *Ansonia*) with respect to *Atelopus* and *Dendrobates* was supported (ML BS=92%, BPP=1.00). Although relationships

among bufonid genera are generally unresolved, *Pelophryne* and *Ansonia* formed a clade (ML BS=79%, BPP=0.99), and the monophyly of *Ansonia* was strongly supported (ML BS=97%, BPP=1.00). As in a previous report (Matsui et al., 2010), *Ansonia* is clearly divisible into two sister clades. In one clade (ML BS=84%, BPP=1.00), *A. latidisca* was a sister species to Clade A of Matsui et al. (2010: ML BS=72%, BPP=0.94), including Subclade A1 (ML BS=98%, BPP=1.00) from Peninsular Malaysia and Thailand and Subclade A2 (ML BS=99%, BPP=1.00) from Borneo. The other was a primarily Bornean Clade B of Matsui et al. (2010: ML BS=100%, BPP=1.00), including Bornean and Philippine species, and one species from the Peninsular Malaysia. From the species of each clade and subclade, *A. latidisca* exhibited substantially large uncorrected p-distances in 16S rRNA of at least 9.3% (between *A. fuliginea* [Mocquard, 1890] in Clade B), 9.4% (between *A. minuta* in Subclade A2), and 9.9% (between *A. jeetsukumarani* Wood, Grismer, Ahmad, and Senawi, 2008 in Subclade A1), which indicate its intermediate position among the three *Ansonia* clades/subclades.

#### DISCUSSION

*Ansonia latidisca* is morphologically more similar to *S. maculatus* than to most congeneric species in having a fairly large, slender body, very long, slender forelimbs, large spatulate finger disks, and moss-like body color (Inger, 1966; Inger et al., 2001 [as *A. anotis*]; Matsui et al., 2007: Fig. 7). The two species also resemble one another ecologically. The three specimens of *A. latidisca* were found on a slope far apart from a small stream, on leaves or the trunk of huge trees or on a huge rock, 1.5–2 m above ground. Similarly, some individuals of *S. maculatus* are reported to have been found 10 m apart from the edge of a small stream, 1–2 m above ground on the trunk of a huge tree, mostly in or near a small hole in the trunk, although others were found on a log beside a stream or on a rock at one



FIG. 7. *Ansonia latidisca* (A) and *Sabahphrynus maculatus* (B), showing their morphological resemblance.

bank of a stream (Inger et al., 2001; Matsui et al., 2007).

However, the two species decidedly differ by the presence in *A. latidisca* and absence in *S. maculatus* of a distinct tympanum (Fig. 8). Analyses of mitochondrial DNA genes also revealed that the two species are very remote genetically. Since both *A. latidisca* and *Sabahphrynus* are seemingly adapted to arboreal life with similar habitat preferences, their similarity in general morphology is most likely the consequence of convergence.

As reported by Matsui et al. (2010), the genus *Ansonia* is clearly divisible into Clade A from Peninsular Malaysia, Thailand (Subclade A1) and Borneo (Subclade A2), and Clade B from Borneo and the Philippines. Of the two lineages from Borneo, species in Clade A are generally smaller than those in Clade B, and large size of *A. latidisca* suggested its

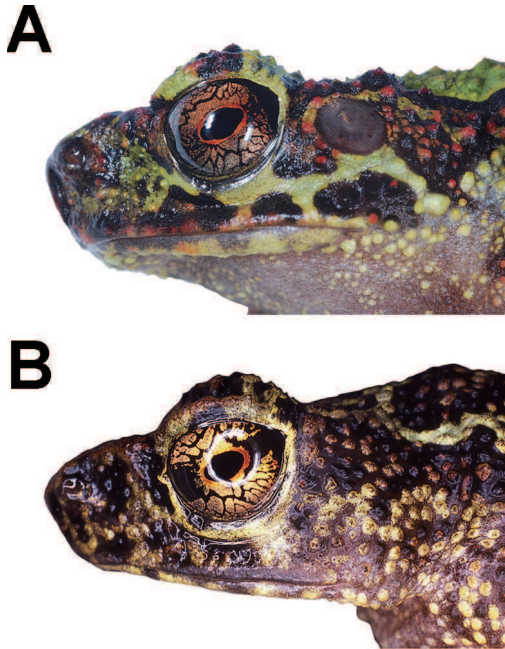

FIG. 8. Lateral views of heads of *Ansonia latidisca* (A) and *Sabahphrynus maculatus* (B), showing the presence in *A. latidisca* and absence in *S. maculatus* of tympanum.

position in Clade B. However, the species was actually basal to the two subclades in Clade A, suggesting its primitive nature within this clade. This finding is significant in suggesting that the genus *Ansonia* originated within Borneo.

Johann Gottfried Hallier, the collector of the holotype of *A. latidisca*, is a German botanist and was an temporary Assistant at the Buitenzorg Herbarium, Java between 1893 and 1896. He traveled to Gunung Damoes, Sambas, Kalimantan, only once between 22 and 24 October 1893 (Van Steenis Kruseman, 2011). Thus the specimen is thought to have been collected during this period. Although detailed data of collection for other specimens are not available, the long absence of collection seems to be partly ascribable to its arboreal habits, probably like *Sabahphrynus maculatus*, which is also arboreal and remained uncollected for nearly 100 years after its initial discovery (Inger, 1966; Inger et al., 2001;

Matsui et al., 2007).

Recent intensive surveys revealed that *A. latidisca* is not extinct as once suspected (Stuart et al., 2008), and inhabits at least the primary forest of westernmost Sarawak (Conservation International, 2011). However, the populations are confined to small areas and probably require conservation (Stuart et al., 2008). There still remain many basic issues to be surveyed including breeding habits and larval habitat. From our survey, late February seems to be outside the breeding season, and field surveys in different seasons would be the first step for considering measures of conservation.

#### ACKNOWLEDGEMENTS

The field survey in Sarawak by MM and KN was made under research permissions of Pejabat Jabatan Perhutanan (NPW. 907.4.4(V)-93 and NCCD.907.4.4(Jld.VI)-122). The Sarawak Forestry Corporation and the Sarawak Biodiversity Centre kindly provided facilities for conducting research. We are grateful to the following for their encouragements and/or permission to conduct research and export specimens: Datu Haji Len Talif Salleh, Haji ali Bin Yusop, Marker Nyogin, Mohd. Shabudin Sabki, Uning, Haji Abang Mohamad Mohtar Bin Abang Pawozan, and Takao Ichioka. We thank Tsutomu Hikida for field companionship and Indraneil Das for providing important information. Field trips were made possible by grants from The Monbusho through the Japan Society for the Promotion of Science (Field Research, Nos. 20405013 and 23405014) to MM.

#### LITERATURE CITED

- DARST, C. R. AND CANNATELLA, D. C. 2004. Novel relationships among hylid frogs inferred from 12S and 16S mitochondrial DNA sequences. *Molecular Phylogenetics and Evolution* 31: 462–475.
- CONSERVATION INTERNATIONAL 2011. Lost amphibian stages amazing reappearing act in Borneo after eluding scientists for 87 years. <http://www.>

- conservation.org/newsroom/pressreleases/Pages/Lost\_mphibian\_Stages\_Amazing\_Reappearing\_Act.aspx
- FROST, D. R. 2011. *Amphibian species of the world: an online reference. Version 5.5 (31 January, 2011)*. American Museum of Natural History, New York. <http://research.amnh.org/vz/herpetology/amphibia/index.html>
- FROST, D. R., GRANT, T., FAIVOVICH, J. N., BAIN, R. H., HAAS, A., HADDAD, C. F. B., DE SA, R. O., CHANNING, A., WILKINSON, M., DONNELLAN, S. C., RAXWORTHY, C. J., CAMPBELL, J. A., BLOTTO, B. L., MOLER, P., DREWES, R. C., NUSSBAUM, R. A., LYNCH, J. D., GREEN, D. M., AND WHEELER, W. C., 2006. The amphibian tree of life. *Bulletin of American Museum of Natural History* 297: 1–370.
- GASSÓ MIRACLE, M. E., VAN DEN HOEK OSTENDE, L. W., AND ARNTZEN, J. W. 2007. Type specimens of amphibians in the National Museum of Natural History, Leiden, The Netherlands. *Zootaxa* 1482: 25–68.
- INGER, R. F. 1966. The systematics and zoogeography of the Amphibia of Borneo. *Fieldiana: Zoology* 52: 1–402.
- INGER, R. F., TAN, F. L., AND YAMBUN, P. 2001. A new species of toad of the genus *Ansonia* (Anura: Bufonidae) from Borneo. *Raffles Bulletin of Zoology* 49: 35–37.
- MATSUI, M. 1984. Morphometric variation analyses and revision of the Japanese toads (genus *Bufo*, Bufonidae). *Contributions from the Biological Laboratory, Kyoto University* 26: 209–428.
- MATSUI, M. 1994. A taxonomic study of the *Rana narina* complex, with description of three new species (Amphibia: Ranidae). *Zoological Journal of the Linnean Society* 111: 385–415.
- MATSUI, M., KHONSUE, W., AND NABHITABHATA, J. 2005. A new *Ansonia* from Isthmus of Kra, Thailand (Amphibia, Anura, Bufonidae). *Zoological Science* 22: 809–814.
- MATSUI, M., TOMINAGA, A., LIU, W.-Z., KHONSUE, W., GRISMER, L. L., DIOSMOS, A. C., DAS, I., SUDIN, A., YAMBUN, P., YONG, H.-S., SUKUMARAN, J., AND BROWN, R. M. 2010. Phylogenetic relationships of *Ansonia* from Southeast Asia inferred from mitochondrial DNA sequences: Systematic and biogeographic implications (Anura: Bufonidae). *Molecular Phylogenetics and Evolution* 54: 561–570.
- MATSUI, M., YAMBUN, P., AND SUDIN, A. 2007. Taxonomic relationships of *Ansonia anotis* Inger, Tan, and Yambun, 2001 and *Pedostibes maculatus* (Mocquard, 1890), with a description of a new genus (Amphibia, Bufonidae). *Zoological Science* 24: 1159–1166.
- STUART, S. N., HOFFMAN, M., CHANSON, J. S., COX, N. A., BERRIDGE, R., RAMANI, P., AND YOUNG, B. E. 2008. *Threatened Amphibians of the World*. Lynx Edicions, IUCN, and Conservation International, Barcelona, Gland, and Arlington.
- TANABE, A. S. 2011. Kakusan4 and Aminosan: two programs for comparing nonpartitioned, proportional, and separate models for combined molecular phylogenetic analyses of multilocus sequence data. *Molecular Ecology Resources* 11: 914–921.
- VAN STEENIS KRUSEMAN, M. J. 2011. *Cyclopaedia of Malesian Collectors*. National Herbarium Netherland, Leiden. <http://www.nationaalherbarium.nl/fmcollectors/h/HallierJG.htm>
- WILKINSON, J. A., SELAS, A. B., AND VINDUM, J. V. 2012. A new species of *Ansonia* (Anura: Bufonidae) from northern Tanintharyi Division, Myanmar. *Zootaxa* 3163: 54–68.

---

Accepted: 17 September 2012



## Field Observation of Egg-laying Behavior of a Puddle Frog *Occidozyga sumatrana* from Bali, Indonesia (Anura: Dicroglossidae)

KOSHIRO ETO AND MASAFUMI MATSUI\*

*Graduate School of Human and Environmental Studies, Kyoto University, Yoshida Nihonmatsu-cho, Sakyo-ku, Kyoto 606–8501, JAPAN*

**Abstract:** *Occidozyga sumatrana* is not uncommon in some parts of Southeast Asia but its reproduction in nature is poorly known. We observed egg-laying behavior of this species in Bali, Indonesia. The amplexic position was inguinal and the oviposition site was out of the water in *O. sumatrana*, both of which are unique given its phylogenetic position and the mainly aquatic habits of adults.

**Key words:** Behavior; Indonesia; Inguinal amplexus; *Occidozyga sumatrana*; Terrestrial oviposition

### INTRODUCTION

The genus *Occidozyga* Kuhl and van Hasselt, 1822 occurs chiefly in Southeast Asia, and consists of a small number of tiny frog species living around still-waters such as puddles, marshes, or swamps. *Occidozyga sumatrana* (Peter, 1877), which is often confused with *O. laevis* (Günther, 1858), occurs in Sundaland (Iskandar, 1998; Frost, 2011). Although this species is very common in some areas, their reproductive ecology in nature has been poorly known. Here, we report a case of egg-laying behavior of *O. sumatrana* observed in a rice field in Bali, Indonesia.

### MATERIALS AND METHODS

Observations were made at a terraced rice field area in Ubud (8°27'34"S, 115°16'21"E), Bali, Indonesia, from the middle of the night to early morning of 4 August 2012. The area is scattered with patches of short trees and bushes. The dry season usually lasts from April to October in Bali, but it rained lightly on the day prior to our observations, and it was relatively cool and humid at night. The air and water temperatures near and in the channel where observations were made were 21.9C and 23.1C, respectively, at the beginning of observation.

We initially observed frogs with a small fluorescent lamp, but because this appeared to alter their behavior, we used a red LED lamp. However, after reproductive behavior began, we again used a fluorescent lamp for detailed observation and video recording (Sony HDW-750). After the observations were completed, we collected the frogs, deeply anesthetized them in saturated chloroform, and fixed in 10% formalin. For specimens later transferred to 70% ethanol, we took measurements of body size and made gross inspection of the condition of oviducts and ovaries of the female by dissection.

### OBSERVATIONS

We found an amplexant pair of *O. sumatrana* in a small channel surrounded by rice fields. The channel with a muddy bottom was approximately 8 m in length, 20–70 cm in width, and 50 cm in depth. The water in the channel was shallow (<5 cm) and moving slowly, eventually flowing into the rice field. Both sides of the channel, which were nearly vertical, were formed by muddy soil and continued to the edge of the rice field. Some other frog species (*Microhyla palmipes* Boulenger, 1897, *Fejervarya* cf. *limnocharis*, *F. cancrivora* (Gravenhorst, 1829), and *Hylarana nicobariensis* (Stoliczka, 1870) were calling around the channel and rice field, but the calls of *O. sumatrana* and *M. palmipes* were heard

---

\* Corresponding author. Tel/FAX: +81–75–753–6846;  
E-mail address: fumi@zoo.zool.kyoto-u.ac.jp



FIG. 1. An inguinally amplexant pair of *Occidozyga sumatrana* found in a rice field area of Bali.

most frequently.

An amplexant pair of *O. sumatrana* (male SVL=29.5 mm; female SVL=38.0 mm) was found in the channel, where the width was 60 cm, at 0150 h. The male was holding the inguinal region of the female (Fig. 1). The pair stayed in the water close to the left wall, with their heads facing downstream. At this time, the pair was frightened by the light of the lamp and the male released the female.

At 0155 h, after we changed the lamp, the male called twice behind the female, jumped in front of her, and gave three calls. These calls sounded like normal advertisement calls (Matsui and Eto, unpublished data). Subsequently, the female jumped directly in front of the snout of the male, and they resumed amplexus (0200 h). Just after grasping the female, the male slightly shook his body for a short time. The pair started moving at 0242 h. First they jumped forward in a downstream direction several times, and then turned upstream at 0316 h. Then they turned again (0339 h) and moved downstream. At 0354 h, they climbed the left wall approximately 10 cm, and moved upstream on the wall. During this movement, the female occasionally pressed her head to the wall and dug the soil with her forelimbs. At this time we turned the fluorescent lamp on again for detailed observation and video recording. The pair moved down the wall at 0413 h, moved upstream, then turned their heads towards the left wall.



FIG. 2. Egg-laying behavior of *Occidozyga sumatrana* in a hole above the water.

There was a small hollow (2.5 cm in maximum diameter) on the wall, 10 cm above the water. The female first put her head into the hollow, then turned her body. The posterior half of their bodies were put inside, with the rest of their bodies largely exposed. At 0419 h they started laying the first egg mass. The female inclined her head and elevated her pelvic region by standing on fully stretched hindlimbs, and then put the egg mass on the ceiling of the hollow. During oviposition, the body of the male was shifted anteriorly (downwards) so that the cloacae of both frogs were positioned closely together, although the forelimbs of the male still held the female's waist (Fig. 2). Oviposition was short, lasting approximately three sec. Egg diameter was about 1.2 mm and the number of eggs laid was eight.

The pair started moving again at 0423 h. They moved up and down the wall several times in an upstream direction. At 0431 h, they finally went into a small hole on the left wall head first. The hole was located at approximately 90 cm upstream from the first hollow, and was 10 cm above the bottom of the wall and 20 cm distant from the water. The maximum diameter of the hole was 4 cm but its depth was undetermined because it was winding inside. The hole might have been made by other animals (e.g., crabs or small mammals).



FIG. 3. Two egg masses (shown by arrows) that were successively attached to upper part of a hole by *Occidozyga sumatrana*.

The pair turned around in the hole, facing out of the hole, and started laying the second egg mass at 0440 h. The egg mass was laid on a grass root emerging from the ceiling of the hole entrance. At 0444 h the third egg mass was laid next to the second one, again on the ceiling of the hole (Fig. 3). There were 12 and 10 eggs in the second and third egg masses, respectively. At 0448 h, when the female stretched her hindlimbs and assumed an egg-laying posture, the male jumped to leave her. The female maintained the posture for a few sec, but then jumped into the water.

We found four more egg masses, each containing 10 to 14 eggs, around the channel and surrounding rice fields, and all of them were laid directly on muddy slopes or in holes close to water. No egg masses were found under the water despite our intensive search there.

The female had no eggs in her oviducts after the above breeding activity, but she did have a large number of eggs of various size in her ovaries. We also observed another pair of *O. sumatrana* (male SVL=26.5 mm; female SVL=37.0 mm), which laid their eggs in a plastic bag after collection. A total number of 40 eggs in at least three separate masses were obtained, and no egg was found in the oviduct of the female.

## DISCUSSION

From these observations, *O. sumatrana* in Bali is thought to lay a small number of eggs (about 30–40 at one breeding activity) on the wet ground close to the water in multiple small egg masses (each containing 8–14 eggs). However, it is possible that the two pairs we studied had already laid some egg masses before they were found and that the true clutch size of the female is larger. This is because we found many eggs of various sizes still left in ovaries in the females. The species may actually lay multiple clutches intermittently during a prolonged breeding season like some other anuran species (e.g., *Pelophylax porosa brevipoda* [Ito, 1941] [Matsui and Kokuryo, 1984]; *Fejervarya kawamurai* Djong, Matsui, Kuramoto, Nishioka and Sumida, 2011 [Sichi et al., 1988]).

The present observation, in which *O. sumatrana* adopts an inguinal amplexus, is interesting because this is not common in neobatrachians. Inguinal amplexus is universally seen in primitive frogs (archaeobatrachians or mesobatrachians), whereas most derived frogs adopt axillary amplexus with a few exceptions (Duellman and Trueb, 1994). Thus inguinal amplexus in *O. sumatrana* is thought to be a secondary modification among neobatrachians. Because a congeneric species *O. martensii* (Peters, 1867) also exhibits inguinal amplexus (Ziegler, 2002; Chanard, 2003), this amplexic style is probably common in this genus. However, little information about amplexic postures is available for the family Dicroglossidae Anderson, 1871 and whether or not inguinal amplexus is limited to the genus *Occidozyga* is unknown.

Another interesting issue is the terrestrial oviposition of *O. sumatrana* the adult of which is often found in or around the water and known to prefer aquatic habitats like its congeners (Iskandar, 1998). The functions of inguinal amplexus and terrestrial oviposition in *O. sumatrana* are not clear, but some suggestions about the amplexic position are provided by our observation. When the female

of *O. sumatrana* inclines her head and elevates the pelvic region by standing on fully stretched hindlimbs for oviposition, the male's body is forced to slide anteriorly resulting in his cloaca being located at nearly the same or little bit anterior position of the female's cloaca despite keeping an inguinal amplexic posture. This situation seems to be attained by the male's smaller body size than the female. If amplexus was axial, the cloaca of the male would be positioned too far forward of the female's cloaca, resulting in less efficient fertilization of eggs, which are apparently attached to the ceilings of holes or hollows. Thus, inguinal amplexus of *O. sumatrana* may be related to its sexual size dimorphism and terrestrial oviposition.

One reason for terrestrial oviposition might be to protect eggs from carnivorous conspecific tadpoles (Iskandar, 1998), although larvae of this species in Bali did not seem to favor frog eggs as far as we could determine (Eto, unpublished data). For more detailed discussion, it is necessary to assess the amplexic positions and oviposition sites of other species of *Occidozyga* and of dicroglossids in general.

#### ACKNOWLEDGEMENTS

We thank A. Iwata, G. Yamada, E. Simanjuntak, and N. Nishikawa for their help and video recording during observations. We also thank two anonymous reviewers for improving an earlier version of the manuscript. This work was partially supported by a grant from

The Monbukagakusho through the Japanese Society for the Promotion of Sciences (JSPS: 23510294) to MM.

#### LITERATURE CITED

- CHAN-ARD, T. 2003. *A Photographic Guide to Amphibians in Thailand*. Darnsutha Press, Bangkok.
- DUELLMAN, W. E. AND TRUBE, L. 1994. *Biology of Amphibians*. Johns Hopkins University Press, Baltimore, Maryland.
- FROST, D. R. 2011. *Amphibian species of the world: an online reference. Version 5.5 (31 January, 2011)*. American Museum of Natural History, New York. <http://reaserach.amnh.org/vz/herpetology/amphibia/index.html>
- ISKANDAR, D. T. 1998. *The Amphibians of Java and Bali*. Research and Development Centre for Biology-LIPI, Bogor.
- MATSUI, M. AND KOKURYO, Y. 1984. Die Fortpflanzungsstrategie weiblicher Japanischer Teichfrosche *Rana porosa brevipoda* Ito, 1941 in Kyoto, Japan. *Salamandra* 20: 233–247.
- SICHI, N., SERIZAWA, T., AND SERIZAWA, S. 1988. Growth and development of *Rana limnocharis* in Kariya-shi, Aichi Prefecture, central Japan. *Japanese Journal of Herpetology* 12: 95–101.
- ZIEGLER, T. 2002. *Die Amphibien und Reptilien eines Tieflandfeuchtwald-Schutzgebietes in Vietnam*. Natur und Tier-Verlag, Münster.

---

*Accepted: 25 September 2012*



<http://dx.doi.org/10.11646/zootaxa.3670.4.9>

<http://zoobank.org/urn:lsid:zoobank.org:pub:EE8234D8-6B6E-406C-9F6D-A82D5021731D>

## Description of a new species of *Microhyla* from Bali, Indonesia (Amphibia, Anura)

MASAFUMI MATSUI<sup>1,3</sup>, AMIR HAMIDY<sup>1,2</sup> & KOSHIRO ETO<sup>1</sup>

<sup>1</sup>Graduate School of Human and Environmental Studies, Kyoto University, Yoshida Nihonmatsu-cho, Sakyo-ku, Kyoto 606-8501, Japan

<sup>2</sup>Museum Zoologicum Bogoriense, Research Center for Biology, Indonesian Institute of Sciences, Gd. Widiasatwaloka, Jl. Raya Jakarta Bogor Km 46, Cibinong West Java, Indonesia

<sup>3</sup>Corresponding author. E-mail: [fumi@zoo.zool.kyoto-u.ac.jp](mailto:fumi@zoo.zool.kyoto-u.ac.jp)

### Abstract

We describe a microhylid frog from Bali, Indonesia as a new species, *Microhyla orientalis* **sp. nov.** It belongs to the *M. achatina* group and is close to *M. mantheyi*, *M. malang*, and *M. borneensis*. It is distinguished from its congeners by a combination of the following characters: small size (adult males about 16–17 mm in SVL); a faint vertebral stripe present; a black lateral stripe from behind eye to half length of trunk; snout rounded in profile; eyelid without supraciliary spines; first finger less than one-fifth of third; tips of three outer fingers weakly dilated, forming weak disks, dorsally with median longitudinal groove; outer palmar tubercle single; tibiotarsal articulation reaching up to center of eye; tips of toes distinctly dilated into disks, dorsally with median longitudinal groove; inner and outer metatarsal tubercles present; four or more phalanges on inner and outer sides of fourth toe, and three phalanges on inner side of fifth toe free of web; and tail of larva with a black marking at middle. The male advertisement call of the new species consists of a series of notes each lasts for 0.01–0.08 s and composed of 3–5 pulses with a dominant frequency of 3.2–3.6 kHz. Uncorrected sequence divergences between *M. orientalis* and all homologous 16S rRNA sequences available were >6.6%. At present, the new species is known from rice fields between 435–815 m elevation in Wongaya Gede and Batukaru.

**Key words:** new species, mtDNA phylogeny, *Microhyla orientalis*, Java, taxonomy

### Introduction

The island of Bali is located at the westernmost of the Lesser Sundas. The island is separated in the west from the Java Island, which belongs to the Greater Sundas, by the Strait of Bali with a minimum distance of only 3 km, and in the east from the Lombok Island by the Lombok Strait, with a distance of 35 km (Fig. 1); all of these islands together form a chain-like archipelago. The area of the island is 5,561 km<sup>2</sup>, and many volcanoes are present in the north, and many waterways run in the south (Whitten & Soeriaatmadja 1996).

Considering the small size and topography of the island, the amphibian fauna of Bali is expected to be limited. Indeed, the amphibian fauna of Bali is not diverse and Iskandar (1998) listed only 14 species of anuran from the island: *Leptobranchium hasseltii* Tschudi, *Bufo* (= *Ingerophrynus*) *biporcatus* Gravenhorst, *Bufo* (= *Duttaphrynus*) *melanostictus* Schneider, *Kaloula baleata* (Müller), *Microhyla palmipes* Boulenger, *Oreophryne monticola* (Boulenger), *Rana* (*Aquarana*) *catesbeiana* (Shaw) (introduced, = *Lithobates catesbeianus*), *Rana* (*Hylarana*) *chalconota* (Schlegel), *Rana* (*Hylarana*) *nicobariensis* (Stoliczka), *Fejervarya cancrivora* (Gravenhorst), *Fejervarya limnocharis* (Gravenhorst), *Occidozyga lima* (Gravenhorst), *Occidozyga sumatrana* (Peters), and *Polypedates leucomystax* (Gravenhorst). More recently, McKay (2006) noted 15 anuran species on the island, with *O. lima* being excluded but *O. laevis* (Günther) and *Microhyla achatina* (Tschudi) added to Iskandar's (1998) list. McKay's (2006) *O. laevis* should represent *O. sumatrana* (Eto & Matsui 2012), while *M. achatina* is considered to represent the new species described in this paper.

Notwithstanding its poor anuran diversity, the geographic position of Bali is noteworthy, and the island has received biogeographical attention because Bali and neighboring Lombok form the famous Wallace line, now regarded as the western boundary of the Wallacea. Of the species listed above, the occurrence of a microhylid, *Oreophryne monticola*, is biogeographically significant, because the genus is Australo-Papuan. Since *Oreophryne* sometimes oviposit in hollow aerial tubers of epiphytes where embryos develop directly, Inger (1954) suggested waif dispersal to explain distribution of the genus in Sulawesi. However, the origin of the population in Bali has never been seriously discussed so far (e.g. Inger 1999; Kurabayashi *et al.* 2011). In contrast, for the microhylid genus *Microhyla*, Bali is the easternmost edge of its distribution, and the factors limiting the distribution of the genus have also never been discussed. Therefore, Bali remains key to understanding microhylid evolution. To date, only *M. palmipes* and *M. achatina* have been reported from the island (Iskandar 1998; McKay 2006), but recent herpetological surveys on the island resulted in the collection of an unknown species of *Microhyla* (Matsui *et al.* 2011), which seems to have been confused with *M. achatina* by McKay (2006). Based on its distinct genetic difference from all the other taxa examined, Matsui *et al.* (2011) proposed to treat the specimen as a probable distinct species, *Microhyla* sp. 2 from Bali, but retained description from a single specimen then available.

Additional survey of the species on the island in 2012 resulted in the collection of both metamorphosed and larval specimens, as well as recording of calls. Later close genetic and morphological examination using these new materials proved the species to be different from all other congeners, including *M. palmipes* or *M. achatina*, hence we described it as a new species.

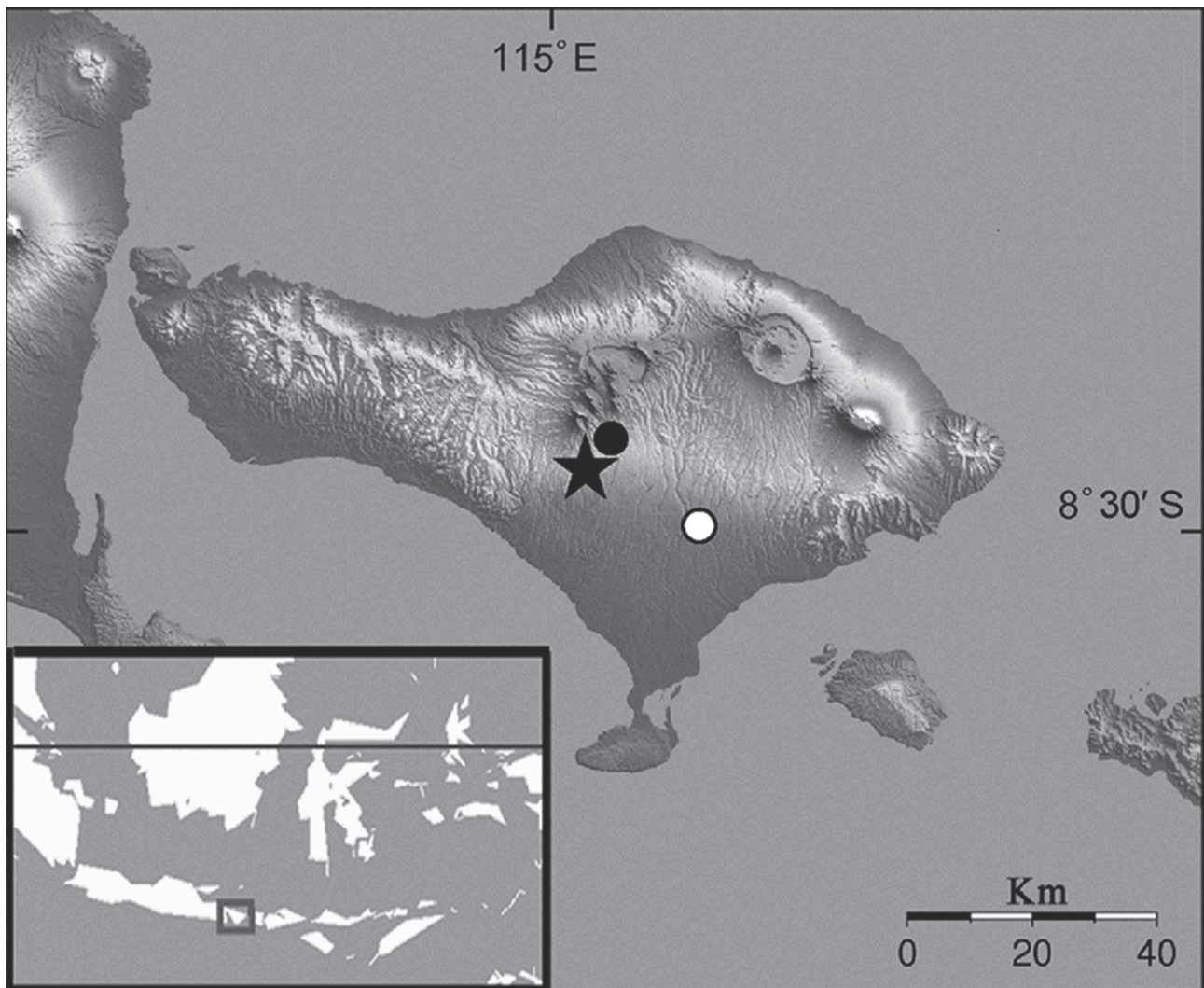

**FIGURE 1.** Map of Bali, Indonesia, showing the known distributions of *Microhyla orientalis* **sp. nov.** The filled star and filled circle, respectively, indicate the type localities of Wongaya Gede and Batukaru. *Microhyla palmipes* was sympatric with *M. orientalis* at both localities. The open circle indicates Ubud, where only *M. palmipes* was found.

## Material and methods

For adult specimens stored in 70% ethanol, we took the following 18 body measurements to the nearest 0.1 mm, following Matsui (1984, 1994, 2011): (1) snout-vent length (SVL); (2) head length (HL), from tip of snout to hind border of angle of jaw (not measured parallel to the median line); (3) eye length (EL); (4) eye diameter (ED), diameter of the exposed portion of the eyeball; (5) head width (HW); (6) internarial distance (IND); (7) interorbital distance (IOD); (8) upper eyelid width (UEW); (9) forelimb length (FLL); (10) lower arm and hand length (LAL), from elbow to tip of third finger; (11) inner palmar tubercle length (IPTL); (12) outer palmar tubercle length (OPTL); (13) hindlimb length (HLL); (14) tibia length (TL); (15) foot length (FL); (16) inner metatarsal tubercle length (IMTL); (17) first toe length (1TOEL), from distal end of inner metatarsal tubercle to tip of first toe; and (18) outer metatarsal tubercle length (OMTL). Additionally, we also used a binocular dissecting microscope to measure: (19) snout length (SL); (20) nostril-eyelid length (N-EL); (21) snout-nostril length (S-NL); (22) first finger width (1FW), measured at the distal phalanx; (23–25) finger disk diameters (2–4FDW); (26–30) toe disk diameters (1–5TDW); and (31–36) finger lengths (1–3FLO, 2–4FLI), for outer side (O) of the first, inner side (I) of the fourth, and both sides of the remaining fingers, measured between tip and the junction of the neighboring finger. We followed the system of description of toe-webbing states used by Savage & Heyer (1967).

For larvae preserved in 5% formalin, the following 14 measurements were taken to the nearest 0.1 mm using a binocular dissecting microscope equipped with a micrometer: (1) total length; (2) head-body length; (3) maximum head-body width; (4) maximum head-body depth; (5) eye-snout distance; (6) eyeball diameter; (7) interorbital distance; (8) snout-spiracle opening distance; (9) oral disk width; (10) tail length; (11) maximum tail depth; (12) maximum tail width; (13) maximum tail muscle depth; and (14) upper fin depth at middle of tail. For staging, we followed Shimizu & Ota's (2003) table for a congeneric species.

For the acoustic data, we recorded frog calls in the field using a digital recorder (Olympus LS-11) at 44.1 kHz/16 bit as uncompressed wave files and analyzed them with SoundEdit Pro (MacroMind-Paracomp, Inc.) and Raven Lite 1.0 for Mac OS X (<http://www.birds.cornell.edu/raven>) on a Macintosh computer. Temporal data were obtained from the oscillograms and frequency information was obtained from the audiospectrograms using Fast Fourier Transformation (1024 point Hanning window).

**TABLE 1.** Samples newly used in this study, including GenBank accession numbers. BOR: BORNEENSIS collection, University Malaysia Sabah; KUHE: Kyoto University, Human and Environmental Studies. UL = unnumbered larva.

| Species                        | Voucher No. | Location                      | GenBank  |          |
|--------------------------------|-------------|-------------------------------|----------|----------|
|                                |             |                               | 12S      | 16S      |
| <i>Chaperina fusca</i>         | BOR 8479    | Malaysia, Sabah, Crocker      | AB781451 | AB781462 |
| <i>Microhyla palmipes</i>      | KUHE UL     | Indonesia, Bali, Ubud         | AB781452 | AB781463 |
| <i>Microhyla palmipes</i>      | KUHE 55057  | Indonesia, Bali, Wongaya Gede | AB781453 | AB781464 |
| <i>Microhyla</i> sp. from Bali | KUHE 55048  | Indonesia, Bali, Wongaya Gede | AB781454 | AB781465 |
| <i>Microhyla</i> sp. from Bali | KUHE 55049  | Indonesia, Bali, Wongaya Gede | AB781455 | AB781466 |
| <i>Microhyla</i> sp. from Bali | KUHE 55050  | Indonesia, Bali, Wongaya Gede | AB781456 | AB781467 |
| <i>Microhyla</i> sp. from Bali | KUHE 55072  | Indonesia, Bali, Wongaya Gede | AB781457 | AB781468 |
| <i>Microhyla</i> sp. from Bali | KUHE 55073  | Indonesia, Bali, Wongaya Gede | AB781458 | AB781469 |
| <i>Microhyla</i> sp. from Bali | KUHE 55074  | Indonesia, Bali, Wongaya Gede | AB781459 | AB781470 |
| <i>Microhyla</i> sp. from Bali | KUHE 55076  | Indonesia, Bali, Wongaya Gede | AB781460 | AB781471 |
| <i>Microhyla</i> sp. from Bali | KUHE UL     | Indonesia, Bali, Wongaya Gede | AB781461 | AB781472 |

We obtained DNA sequence data from tissue samples preserved in 99% ethanol. We reconstructed phylogenetic trees from approximately 1800 base pairs (bp) of the partial sequences of mitochondrial 12S and 16S rRNA genes and the intervening tRNA gene for valine to clarify the genetic structure of our own samples of 10 specimens of *Microhyla* from Bali and one outgroup species (Table 1). For comparisons, DNA sequences (12S rRNA, 16S rRNA) already reported Matsui *et al.* (2011) were obtained from GenBank for 16 taxa (17 sequences)

of *Microhyla* and three outgroup species: *M. achatina* (AB634598, AB634656); *M. annectens* (AB634600, AB634658); *M. berdmorei* (AB598314, AB598338); *M. borneensis* (AB634605, AB634663); *M. butleri* (AB634606, AB634664); *M. fissipes* (AB634608, AB634666); *M. heymonsi* (AB598312, AB598336); *M. mantheyi* (AB598310, AB598334); *M. marmorata* (AB634610; AB634668); *M. okinavensis* (AB201173, AB201184); *M. ornata* (AB201176, AB201187); *M. palmipes* (AB634612–13, AB634670–71); *M. perparva* (AB634615, AB634673); *M. petrigena* (AB634617, AB634675); *M. malang* (AB598295, AB598319); *Microhyla* sp. 2 (AB634621, AB634679); *Calluella minuta* (AB598316, AB598340); *Glyphoglossus molossus* (AB201182, AB201193); and *Micryletta inornata* (AB598317, AB598341). Methods for DNA extraction and, amplification and sequencing of the mtDNA fragments are the same as those reported by Matsui *et al.* (2011). The resultant sequences were deposited in GenBank (AB781451–781472: Table 1). The alignment matrix with 1791 mtDNA nucleotide sites (899 sites for 12S rRNA; 892 for 16S rRNA) was subjected to estimate phylogenetic relationships using maximum likelihood (ML) and Bayesian inference. Pairwise comparisons of uncorrected sequence divergences (p-distance) were also calculated for 16S rRNA. Details for all these procedures are given in Matsui *et al.* (2011).

## Results

As a result of molecular phylogenetic analyses, we obtained 1791 bp of concatenated fragments of mtDNA genes for 31 samples, including out-groups (Fig. 2). Of 1791 nucleotide sites, 675 were variable, and 492 were parsimoniously informative. The best substitution model was GTR+G with gamma shape parameter (G) of 0.196 for ML and 0.208 for BI. The likelihood values (-lnLs) of the ML and BI trees were 11916.673 and 11969.347, respectively.

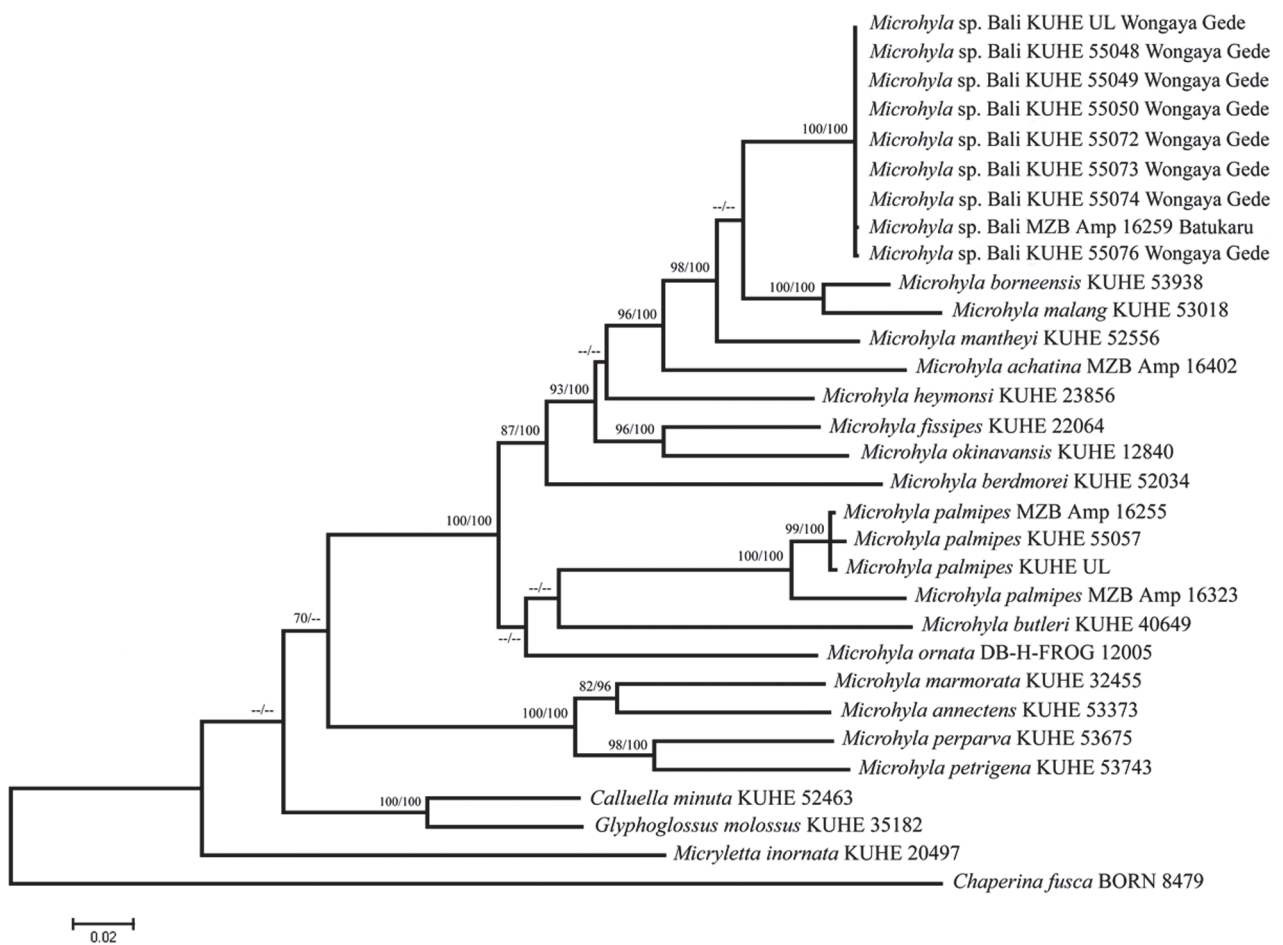

**FIGURE 2.** Maximum likelihood (ML) tree of a 1791 bp sequence of mitochondrial 12S and 16S rRNA for samples of *Microhyla* (for sample details see Table 1 and Matsui *et al.* 2011). Numbers above or below branches represent bootstrap supports for ML inference and Bayesian posterior probability (ML-BS/BPP).



TABLE 2. Uncorrected p-distances (in %) for fragment of 16S rRNA (892 bp) among microhylid taxa compared.

|                                 | 1         | 2         | 3         | 4         | 5         | 6         | 7         | 8         | 9         | 10        | 11        | 12        | 13        | 14        | 15   | 16  | 17      | 18  | 19  |  |
|---------------------------------|-----------|-----------|-----------|-----------|-----------|-----------|-----------|-----------|-----------|-----------|-----------|-----------|-----------|-----------|------|-----|---------|-----|-----|--|
| 1 <i>Chaperina fusca</i>        |           |           |           |           |           |           |           |           |           |           |           |           |           |           |      |     |         |     |     |  |
| 2 <i>Micryletta innomata</i>    | 19.8      |           |           |           |           |           |           |           |           |           |           |           |           |           |      |     |         |     |     |  |
| 3 <i>Calluella minuta</i>       | 18.6      | 14.6      |           |           |           |           |           |           |           |           |           |           |           |           |      |     |         |     |     |  |
| 4 <i>Glyphoglossus molossus</i> | 18.2      | 14.2      | 7.7       |           |           |           |           |           |           |           |           |           |           |           |      |     |         |     |     |  |
| 5 <i>Microhyla annectans</i>    | 20.7      | 14.6      | 13.4      | 13.6      |           |           |           |           |           |           |           |           |           |           |      |     |         |     |     |  |
| 6 <i>Microhyla perparva</i>     | 20.2      | 15.2      | 13.9      | 14.1      | 8.9       |           |           |           |           |           |           |           |           |           |      |     |         |     |     |  |
| 7 <i>Microhyla parrigena</i>    | 21.1      | 15.6      | 12.9      | 14.6      | 8.9       | 7.3       |           |           |           |           |           |           |           |           |      |     |         |     |     |  |
| 8 <i>Microhyla marmorata</i>    | 19.9      | 14.6      | 13.7      | 13.5      | 8.6       | 8.5       | 9.5       |           |           |           |           |           |           |           |      |     |         |     |     |  |
| 9 <i>Microhyla palmipes</i>     | 22.0–22.7 | 16.8–17.9 | 14.2–15.7 | 14.4–15.7 | 14.5–15.9 | 15.1–16.1 | 14.5–15.5 | 14.3–15.0 |           |           |           |           |           |           |      |     |         |     |     |  |
| 10 <i>Microhyla ornata</i>      | 21.1      | 16.7      | 13.5      | 13.8      | 14.9      | 15.0      | 15.4      | 14.6      | 13.8      |           |           |           |           |           |      |     |         |     |     |  |
| 11 <i>Microhyla bulteri</i>     | 20.0      | 17.2      | 14.4      | 15.0      | 15.3      | 15.6      | 14.7      | 14.7      | 13.4      | 13.0      |           |           |           |           |      |     |         |     |     |  |
| 12 <i>Microhyla boehmei</i>     | 20.2      | 17.3      | 14.4      | 14.6      | 15.1      | 17.7      | 15.5      | 17.2      | 15.9      | 13.3      | 14.7      |           |           |           |      |     |         |     |     |  |
| 13 <i>Microhyla okinawensis</i> | 22.9      | 18.0      | 14.4      | 14.7      | 17.5      | 16.8      | 16.7      | 17.8      | 16.4      | 13.3      | 15.5      | 12.3      |           |           |      |     |         |     |     |  |
| 14 <i>Microhyla fissipes</i>    | 22.1      | 16.8      | 14.8      | 14.5      | 16.8      | 16.4      | 15.4      | 16.2      | 13.4      | 12.3      | 14.4      | 12.7      | 8.0       |           |      |     |         |     |     |  |
| 15 <i>Microhyla heymonsi</i>    | 23.2      | 16.5      | 15.2      | 15.7      | 16.5      | 16.3      | 16.5      | 16.8      | 15.2      | 13.6      | 15.2      | 12.7      | 9.7       | 9.3       |      |     |         |     |     |  |
| 16 <i>Microhyla achalina</i>    | 21.1      | 17.2      | 13.6      | 13.9      | 15.3      | 16.5      | 15.8      | 16.0      | 16.0      | 12.1      | 14.5      | 10.6      | 9.8       | 10.7      | 10.7 |     |         |     |     |  |
| 17 <i>Microhyla manthei</i>     | 21.5      | 16.8      | 13.8      | 14.5      | 16.1      | 16.7      | 16.3      | 16.4      | 15.8      | 13.2      | 14.0      | 11.9      | 10.1      | 10.9      | 9.7  | 8.6 |         |     |     |  |
| 18 <i>Microhyla malang</i>      | 21.4      | 17.8      | 14.6      | 15.8      | 16.2      | 16.3      | 16.8      | 16.0      | 15.7      | 13.6      | 14.0      | 13.3      | 11.9      | 10.4      | 10.2 | 9.7 | 7.8     |     |     |  |
| 19 <i>Microhyla borneensis</i>  | 20.8      | 17.6      | 15.1      | 16.0      | 15.6      | 16.5      | 16.2      | 15.4      | 15.4      | 12.9      | 13.2      | 12.7      | 11.1      | 10.5      | 9.4  | 8.2 | 7.5     | 5.1 |     |  |
| 20 <i>Microhyla</i> sp. Bali    | 21.8–21.9 | 16.8–16.9 | 14.6–14.7 | 15.1–15.2 | 15.9–16.0 | 16.8–16.9 | 16.7–16.8 | 16.6–16.8 | 16.1–16.3 | 13.3–13.4 | 14.0–14.2 | 12.9–13.0 | 10.7–10.8 | 11.0–11.1 | 9.8  | 7.3 | 6.6–6.6 | 7.8 | 6.8 |  |

The specimen of *Microhyla* sp. from Bali examined here proved to form a well-supported clade with *M. borneensis* Parker, *M. malang* Matsui, and *M. mantheyi* Das, Yaakob, and Sukumaran, although their relationships were not fully resolved (Fig. 2). The clade containing these four species was sister to *M. achatina*. From the three species in this sister clade, the specimens from Bali exhibited substantially large genetic distances (uncorrected p-distance of 6.6–7.8%: Table 2), values larger than the distance between *M. borneensis* and *M. malang* specimens syntopic on Borneo (5.1%). Furthermore, the specimen of *Microhyla* sp. from Bali is also clearly separated morphologically from all the other congeners, including its sister species, in congruence with genetic separation. Thus, we describe *Microhyla* sp. from Bali as follows:

## Systematics

### *Microhyla orientalis* sp. nov.

**Synonymy:** *Microhyla achatina*: McKay, 2006, p. 34.

**Holotype.** MZB.Amp 20404 (formerly KUHE 55073), an adult male from Wongaya Gede, Bali, Indonesia (08°25'03"S, 115°07'28"E, alt. 435 m a.s.l.: Fig. 1), collected on 7 August 2012 by K. Eto.

**Paratypes.** MZB.Amp16259, an adult female from Batukaru, Bali, Indonesia (08°22'24"S, 115°06'24"E, alt. 815 m a.s.l.), collected on 12 July 2010 by A. Hamidy, M.D. Kusri., and U. Arifin; KUHE 55049, 55074, 55075 (three adult males), KUHE 55050, 55072 (two adult females), and KUHE 55076 (one subadult female) from the type locality, collected from 7 to 8 August 2012.

**Referred specimens.** KUHE 47215 (five tadpoles), collection data same as the holotype.

**Etymology.** The specific epithet is from a Latin word *orientis* denoting eastern, alluding to the fact that the species from Bali represents geographically the easternmost species of *Microhyla*.

**Diagnosis.** The new species is assigned to Microhylidae by the possession of median spiracle in larvae, and to *Microhyla* among members of the family from Southeast Asia by: lack of small spine-like projection of skin at heel and elbow; belly without a brown network; underside of fingers without greatly enlarged tubercles; snout less than twice diameter of eye; inner metatarsal tubercle low, not shovel-like; tympanum hidden by skin (Inger, 1966). A small form of the genus, adult males about 16–17 mm in SVL; snout rounded in profile; first finger short, less than one-fifth of third; tips of three outer fingers weakly dilated, forming weak disks, dorsally with median longitudinal groove; outer palmar tubercle single; tibiotarsal articulation reaching up to center of eye; tips of toes distinctly dilated into disks, dorsally with median longitudinal groove; two or more phalanges on outer side of second toe, more than three phalanges on inner side of third toe, three or more phalanges on outer side of third toe, four or more phalanges on inner and outer sides of fourth toe, and three phalanges on inner side of fifth toe free of web; inner and outer metatarsal tubercles present; eyelid without supraciliary spines; faint vertebral stripe present; a black lateral stripe from behind eye to half length of trunk; tail of larva with a black marking at middle.

**Description of holotype (measurements in mm).** SVL 16.6; habitus moderate (Fig. 3–4); head triangular, wider (5.5) than long (5.1); snout rounded dorsally and in profile, projecting beyond lower jaw; eye shorter (2.2) than snout (3.2); canthus rostralis rounded; lore sloping, very weakly concave; nostril lateral, below canthus rostralis, closer to tip of snout (1.0) than to eye (1.2); interorbital distance (1.6) subequal to internarial distance (1.6), the latter larger than upper eyelid (1.2); pineal spot absent; tympanum hidden; upper jaw edentate; tongue oval, without papillae; slit-like openings to a median subgular vocal sac.

Forelimb short (9.9); fingers thin, free of web, but with slight skin fringes on both sides of second and third and inner side of fourth; second finger slightly longer (measured from inner side 1.9, outer 1.3) than fourth (inner 1.7), latter much longer than first (outer 0.6); tips of three outer fingers weakly dilated and forming weak disks slightly wider than basal phalanges, dorsally with median longitudinal groove; diameter of first finger (0.2) one-third that of third finger disk (0.6), latter one and half times width of phalange; a single outer palmar tubercle (0.6) larger than inner (0.4); distinct, rounded subarticular tubercles, formula 1, 1, 2, 2; nuptial pad absent (Fig. 5).

Hindlimb moderately long (28.5) about three times length of forelimb; tibia long (9.0), heels overlapping when limbs are held at right angles to body; tibiotarsal articulation of adpressed limb reaching to center of eye; foot (9.4) longer than tibia; tips of toes distinctly dilated into disks, much wider than those of fingers (disk diameter of third

toe 0.7), dorsally with median longitudinal groove; third toe longer than fifth; webs between toes poorly developed (Fig. 5) and absent between first and second toes, formula (the number of phallanges free of web): **I** n.a.–n.a. **II** 2–3+ **III** 3–4+ **IV** 4+–3 **V**; subarticular tubercles prominent, rounded, formula 1, 1, 2, 3, 2; inner metatarsal tubercle oval, large, length (0.8) half of first toe (1.6); outer metatarsal tubercle elevated, smaller (0.5) than inner.

Skin smooth above with a few low tubercles scattered; eyelid without supraciliary spines; no supratympanic fold discernible; side of body sparsely scattered with tubercles or low ridges; hindlimb dorsally scattered with few tubercles; ventral side of body and limbs smooth.



**FIGURE 3.** Dorsolateral view of male holotype of *Microhyla orientalis* sp. nov. (MZB.Amp 20404) from Wongaya Gede, Bali, Indonesia.

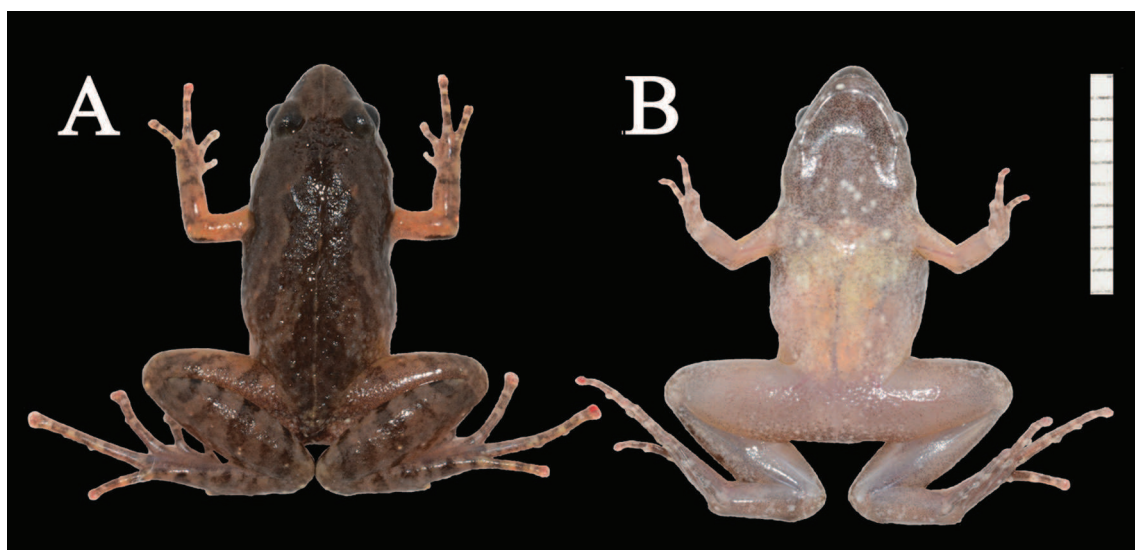

**FIGURE 4.** Dorsal (A) and ventral (B) views of male holotype of *Microhyla orientalis* sp. nov. (MZB.Amp 20404). Scale bar = 10 mm.

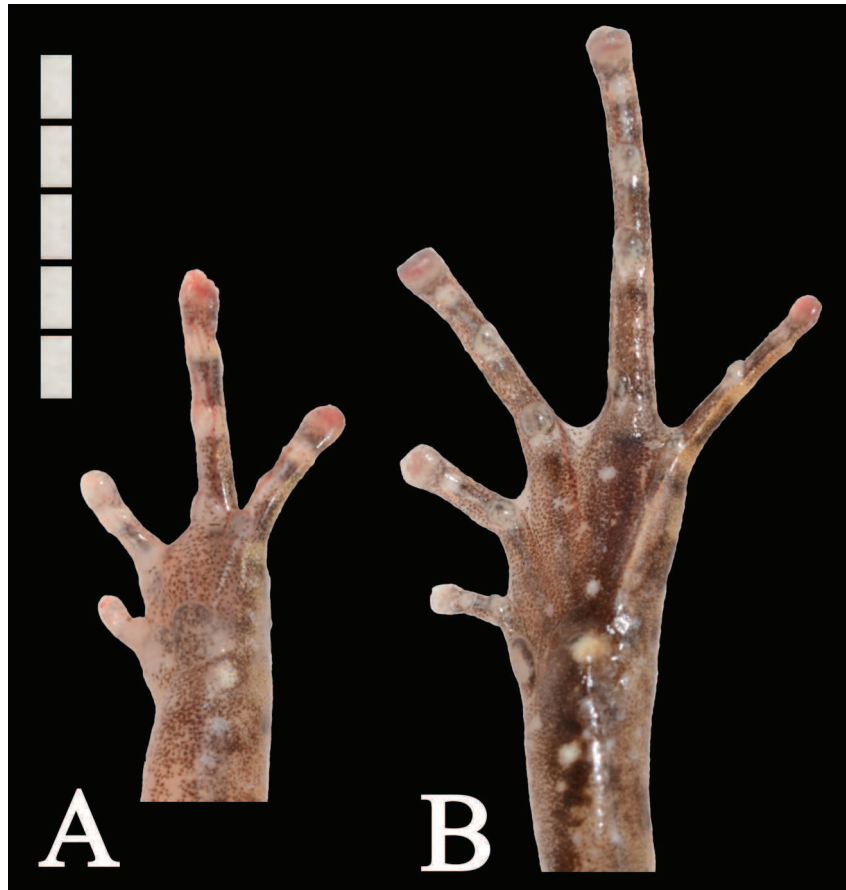

**FIGURE 5.** Ventral view of left hand (A) and foot (B) of male holotype of *Microhyla orientalis* **sp. nov.** (MZB.Amp 20404). Scale bar = 5 mm.

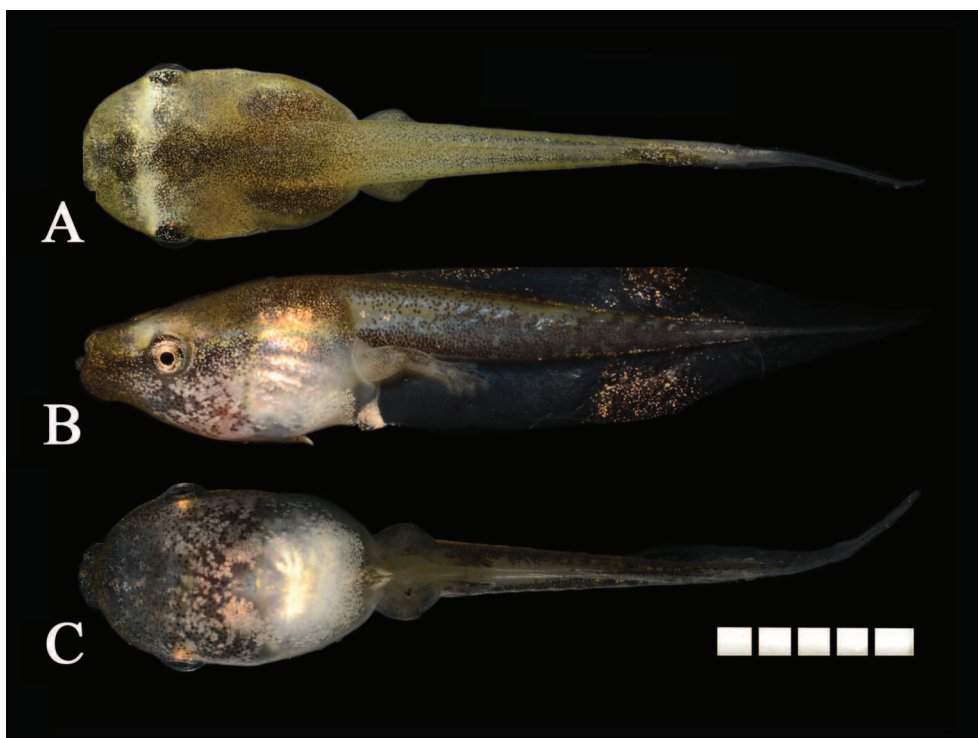

**FIGURE 6.** Larval *Microhyla orientalis* **sp. nov.** from Wongaya Gede, Bali, stage 40 of Shimizu & Ota (2003), total length = 23.2 mm. Dorsal (A), lateral (B), and ventral views (C). Scale bar = 5 mm.

**Color.** Color in life pinkish brown dorsally, with a dark mark medially continued from interorbital bar posteriorly to cloacal opening; interorbital bar, reverse triangle in shape and covering posterior half of upper eyelid; dorsal dark mark forming subtriangle marks on shoulder and behind sacrum, and running laterally to form a wide-limbed reverse V-shaped mark in between on middle of back; a narrow, discontinuous vertebral line from tip of snout to above anus; a black lateral stripe extending from above arm to half length of trunk; a paler dark marking connecting interorbital bar and lateral stripe, dorsally bordering the latter; a dark stripe from snout to eye; a cream stripe extending from eye to axilla; except for upper arm, limbs dorsally with narrow dark brown bars; throat and chest darkly pigmented and abdomen cream white; iris dorsally and ventrally golden with black reticulation, darkly pigmented at anterior and posterior corners (Figs. 3–5). In preservative, pattern has not obviously changed, although color has slightly faded.

**Variation.** Individuals of the type series are generally similar in appearance. Variation in size and body proportions is given in Table 3. Female paratypes have a larger body size (> 18.3 mm SVL) than the males (< 17.4 mm SVL), but tend to have shorter hindlimbs relative to SVL; tibiotarsal articulation of adpressed limbs reaching the posterior border of the eye in females, and the center of the eye in males. Webbing formula was stable for the outer side of the first toe, where web is absent, but slight variations are recognized in other positions, e.g., in a paratype (KUHE 55072), webbing is absent from the first toe to the inner side of the third toe, while another (KUHE 55075) had slight webbing on the inner side of the second toe. Throats of females are less darkly pigmented than those of males.

**TABLE 3.** Measurements of adult *Microhyla orientalis* sp. nov. types. SVL (Mean±1SD, in mm) and medians of ratios (R) of other characters to SVL, followed by ranges in parenthesis. See text for character abbreviations.

|        | Males (N = 5)          | Females (N = 2)     |
|--------|------------------------|---------------------|
| SVL    | 16.7 ± 0.7 (15.8–17.4) | 18.8 (18.3–19.2)    |
| RHL    | 31.4 (30.7–35.4)       | 30.7 (29.7–31.7)    |
| RHW    | 33.1 (32.2–36.7)       | 33.6 (32.8–34.4)    |
| RIND   | 9.2 (8.8–9.9)          | 8.1 (7.7–8.5)       |
| RIOD   | 9.5 (8.8–11.0)         | 9.0 (8.9–9.1)       |
| RUEW   | 7.8 (7.0–8.6)          | 6.7 (6.2–7.3)       |
| REL    | 13.9 (13.1–14.9)       | 13.5 (13.0–14.0)    |
| RED    | 11.4 (10.7–12.9)       | 9.9 (9.5–10.3)      |
| RLAL   | 43.0 (39.7–46.0)       | 41.1 (40.1–42.1)    |
| RFL    | 58.9 (54.1–60.1)       | 53.3 (53.1–53.6)    |
| RIPTL  | 3.1 (2.5–3.8)          | 2.5 (2.3–2.6)       |
| ROPTL  | 3.9 (3.1–4.7)          | 3.6 (3.4–3.7)       |
| RTL    | 54.0 (50.6–56.3)       | 51.5 (50.0–53.0)    |
| RFL    | 56.6 (50.6–57.7)       | 52.6 (51.6–53.6)    |
| RHLL   | 171.5 (159.2–173.0)    | 163.0 (160.0–166.1) |
| RIMTL  | 5.1 (3.4–5.8)          | 3.8 (3.7–3.8)       |
| R1TOEL | 9.3 (7.6–12.7)         | 8.7 (8.1–9.4)       |
| ROMTL  | 3.6 (2.4–5.5)          | 2.5 (2.4–2.5)       |

**Tadpoles.** A total of five tadpoles from St. 39 (total length=19.9 mm, head-body length=7.1 mm) to 40 (23.2 mm, 7.1 mm) from the type locality of *M. orientalis* and identified as that species by DNA analyses were closely examined. Head and body flattened above, spheroidal below; maximum head-body width at level of eye 63–66% (median=63%) of head-body length; maximum head-body depth 84–96% (median=92%) of maximum head-body width; snout broadly rounded, almost truncate in profile; eyes lateral, visible from below, eyeball diameter 14–16% (median=15%) of head-body length; interorbital space very wide, 322–371% (median=337%) of eyeball diameter; eye-snout distance 25–31% (median=29%) of head-body length. Oral disk dorso-terminal, small; lower lip moderately expanded with width 21–25% (median=22%) of maximum head-body width, with a prominent lateral

papilla on each side; labial teeth and jaw sheaths entirely absent, but lower labium scattered with small papillae on lateral margin. Spiracle opening median, without free flap, opening 70–85% (median=81%) of distance from tip of snout to end of body; vent median, in form of long tube directed nearly vertically downward, small opening at edge of ventral fin; thick loops of gut visible ventrally. Tail long and lanceolate, abruptly tapering in posterior half and drawn out into a short filament; tail length 182–251% (median=221%) of head-body length, maximum depth 25–28% (median=26%) of length; dorsal fin originating at end of head-body, with a straight margin, sub-parallel with much deeper ventral fin in anterior half of tail; ventral fin deeper than dorsal throughout anterior to tail tip; caudal muscle moderately strong, maximum tail width 36–44% (median=39%) of maximum head-body width; muscle depth maximum at origin, 52–68% (median=57%) of maximum tail depth, but steadily narrowed posteriorly, with depth at middle of tail shallower than fin depths. Color in life (Fig. 6) light brown on dorsum and laterally, with a pair of paler interorbital markings and darker mid-dorsal band, and marking at end of flank; venter grey and belly semi-translucent; tail at middle with a black marking dotted with golden.

**Range.** The new species is so far known only from Wongaya Gede and Batukaru, Bali Island, Indonesia.

**Natural history.** *Microhyla orientalis* sp. nov. is sympatric with *M. palmipes* on Bali around Wongaya Gede (type locality) and Batukaru, while at Ubud, only *M. palmipes* was found. They are actually syntopic and can be found very close to each other in the localities of sympatry. At Batukaru, calls of *M. orientalis* were frequently heard in mid July, but at Wongaya Gede, calls were rarely heard in early August, while tadpoles approaching to metamorphosis were observed. In both cases, *M. palmipes* was actively calling. Thus the new species may have shorter breeding seasons than *M. palmipes*. Tadpoles were found in paddies with larval *M. palmipes*.

**Call characteristics.** Calls were recorded at Batukaru at an air temperature of 26.0°C at 21:00 h on 12 July 2010 by A. Hamidy. Calls (33 notes from two males were analyzed) consisted of a series of notes each emitted at an interval (between the beginnings of two successive notes) of  $0.54 \pm 0.13$  (0.37–0.97) s (Fig. 7). Each note was composed of  $4.1 \pm 0.7$  (3–5) short pulses and lasted for  $0.07 \pm 0.01$  (0.01–0.08) s. Frequency bands spread over the 1.0–5.3 kHz range, and the dominant frequency was  $3.4 \pm 0.1$  (3.2–3.6) kHz. Frequency and intensity modulations were not marked.

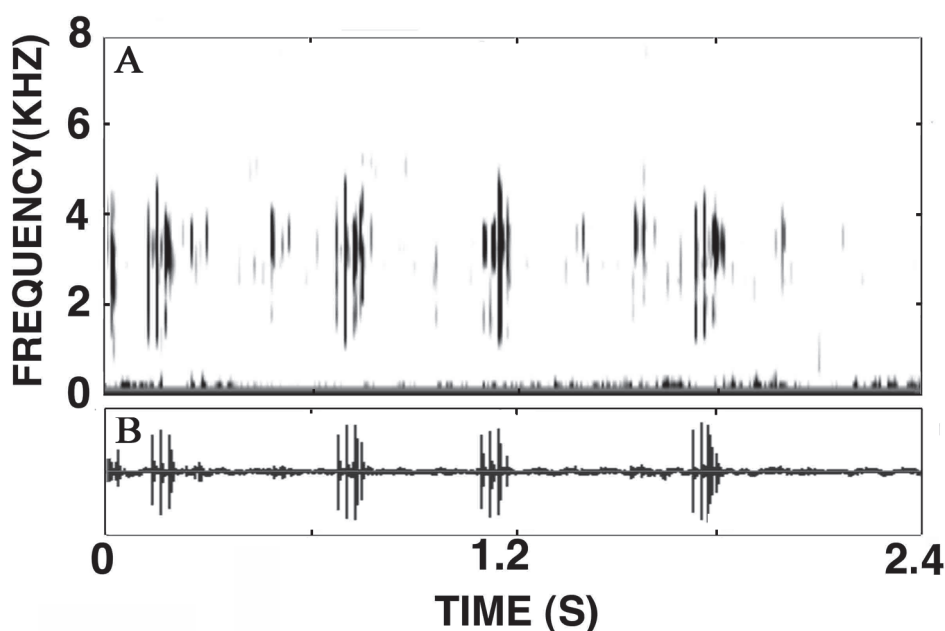

**FIGURE 7.** Sonagram (A) and wave form (B) showing four successive notes of an advertisement call of *Microhyla orientalis* sp. nov. from Batukaru, Bali, recorded at an air temperature of 26.0°C.

**Comparisons.** *Microhyla orientalis* sp. nov. can be differentiated from genetically close members of the *M. achatina* group of Matsui *et al.* (2011) and sympatric congeners in the following way. The new species differs from *M. achatina* by having dorsal dark markings covering the posterior half of the upper eyelid, a lateral dark band beginning at the base of the upper arm and vaguely bordered, and four or five dark bars on limbs (vs. dark marking posterior to upper eyelid, lateral band strong and clearly bordered, and two bars on limbs). From *M. berdmorei*

(Blyth), the new species differs by poorly developed toe webbing (vs. very well developed webbing). The new species differs from *M. borneensis* by larger body size, male SVL 15.8–17.4 mm, and less developed toe webbing, with fifth toe with more than three phalanges free (vs. 11.0–13.2 mm and two phalanges free). The new species differs from *M. fissipes* Boulenger, *M. mixtura* Liu and Hu, *M. okinavensis* Stejneger, and *M. pulchra* (Hallowell) by having finger and toe disks with dorsal median longitudinal grooves (vs. disks and grooves entirely absent or present only on toes). From *M. heymonsi* Vogt, the new species differs by having two metacarpal tubercles and lacking loreal mask or marking on the vertebral line (vs. having three tubercles, a black band covering side of head, and one or two pairs of black marks on sides of vertebral line). The new species differs from *M. malang* by a smaller body size, male SVL 15.8–17.4 mm, and less developed toe webbing, with the fifth toe having more than three phalanges free (vs. 19.4–22.2 mm and one phalange free), and from *M. mantheyi* by a smaller body size, male SVL 15.8–17.4 mm, uniformly brown head, and less developed toe webbing, with the fifth toe with more than three phalanges free (vs. 18.8–29.2 mm, snout cream colored, and one phalange free). Finally, from *M. palmipes*, the new species differs by lacking a supraciliary tubercle, having much less developed toe webbing, and the presence of dorsal median grooves on digital disks (vs. having a supraciliary tubercle and fairly developed toe webbing, and lacking the grooves).

## Discussion

On the basis of phylogenetic analysis of representative microhylid from Southeast Asia using mtDNA genes of 12S rRNA and 16S rRNA, Matsui *et al.* (2011) recognized two subgenera within the genus *Microhyla*: *Microhyla* and an as yet unnamed subgenus. In the subgenus *Microhyla*, four species groups, the *M. palmipes* group, the *M. ornata* group, the *M. butleri* group, and the *M. achatina* group were recognized. *Microhyla orientalis* sp. nov. was nested in the *M. achatina* group as *Microhyla* sp. 2.

Our newly conducted phylogenetic analysis of mtDNA genes using additional samples from Bali yielded results almost identical with those of Matsui *et al.* (2011). Our analyses indicated that *M. orientalis* is phylogenetically closest to *M. mantheyi*, *M. borneensis*, and *M. malang*. Therefore, we suggest that these four species be called the *M. borneensis* subgroup. Frogs of the *M. borneensis* subgroup breed in quiet waters like ponds, pools, and paddies, except for *M. borneensis*, which is specialized to breed in the pitcher of *Nepenthes* (Matsui 2011). *Microhyla orientalis* resembles *M. mantheyi* and *M. malang* in their breeding habit.

Species of the *M. borneensis* subgroup have been recorded from peninsular Thailand to Sumatra and Borneo (Das *et al.* 2007; Matsui 2011). Because many members of the *M. achatina* group sensu Matsui *et al.* (2011: *M. berdmorei*, *M. pulchra*, *M. fissipes*, *M. heymonsi*, and *M. mixtura*) occur on the continent, the *M. borneensis* subgroup most likely originated in the continent and dispersed southeastwards. The new species, *M. orientalis* is the most easterly distributed of the genus, but, strangely, no species of the subgroup has been reported from Java, which is located between Sumatra and Bali.

It is therefore of interest that Iskandar (1998) noted the occurrence of unique tadpoles in Java. According to Iskandar (1998), *Microhyla* tadpoles from Sancang, on the southern coast of west Java, are very similar to those of *M. achatina*. However, unlike typical *M. achatina*, the tadpole in question have a much narrower labial cup, and yellow and black tail fins, all of which match the characteristics of *M. borneensis*, according to Iskandar (1998). Because *M. mantheyi* and *M. malang* were not discriminated from *M. borneensis* at the time of Iskandar's (1998) description, and the tadpole of true *M. borneensis* is a specialized pitcher plant dweller, the tadpoles in question from Western Java may resemble larval *M. mantheyi* (Das *et al.* 2007) or *M. malang* (Matsui 2011).

From Java, two species of *Microhyla*, *M. achatina* and *M. palmipes*, have been recorded (Iskandar 1998), but compared to Bali, Java is much greater in size and it is possible that there are more than two species of *Microhyla* on the island. Because Java has a long history of land development and forest destruction, it is possible that some species have already become extinct on the island. However, it remains worth surveying areas on Java where no herpetological collections have been made in the hope they may be extant.

## Acknowledgments

We thank the directors of the Museum Zoologicum Bogoriense and Research Centre for Biology, (Indonesian Institute of Sciences-LIPI) for permission to A. Hamidy for conducting the survey. AH is indebted to B. Adjie (Bali Botanic Garden LIPI) for facilitation during fieldwork, M.D. Kusriani, U. Arifin for help during fieldwork. AH is also grateful to Monbukagakusho for the scholarship funding support. K. Eto thanks A. Iwata, G. Yamada, E. Simanjuntak, and N. Nishikawa for their help during fieldtrip. K. Nishikawa kindly provided literature. We thank Stephen Goldberg for reviewing English text. This work was partially supported by a grant from The Monbukagakusho through the Japanese Society for the Promotion of Sciences (JSPS: 20405013 and 23510294) to M. Matsui.

## References

- Das, I., Yaakob, N. & Sukumaran, J. (2007) A new species of *Microhyla* (Anura: Microhylidae) from the Malay Peninsula. *Hamadryad*, 32, 304–314.
- Eto, K. & Matsui, M. (2012) Field observation of egg-laying behavior of a puddle frog *Occidozyga sumatrana* from Bali, Indonesia (Anura: Dicroglossidae). *Current Herpetology*, 31, 121–124.
- Inger, R.F. (1954) Systematics and zoogeography of Philippine Amphibia. *Fieldiana: Zoology*, 33, 183–531.
- Inger, R.F. (1999) Distribution of amphibians in Southern Asia and adjacent islands. In: Duellman, W.E. (Ed.), *Patterns of Distribution of Amphibians: A Global Perspective*. Johns Hopkins University Press, Baltimore and London, pp. 445–482.
- Iskandar, D.T. (1998) *The Amphibians of Java and Bali*. Research and Development Centre for Biology, LIPI, Bogor, 117 pp.
- Kurabayashi, A., Matsui, M., Daicus, B.M., Yong, H.-S., Norhayati, A., Sudin, A., Kuramoto, M., Hamidy, A. & Sumida, M. (2011) From Antarctica or Asia? New colonization scenario for Australian-New Guinean narrow mouth toads suggested from the findings on a mysterious genus *Gastrophrynoideus*. *BMC Evolutionary Biology*, 11, 175.  
<http://dx.doi.org/10.1186/1471-2148-11-175>
- Matsui, M. (1984) Morphometric variation analyses and revision of the Japanese toads (genus *Bufo*, Bufonidae). *Contributions from the Biological Laboratory, Kyoto University*, 26, 209–428.
- Matsui, M. (1994) A taxonomic study of the *Rana narina* complex, with description of three new species (Amphibia: Ranidae). *Zoological Journal of the Linnean Society*, 111, 385–415.  
<http://dx.doi.org/10.1111/j.1096-3642.1994.tb01489.x>
- Matsui, M. (2011) Taxonomic revision of one of the Old World's smallest frogs, with description of a new Bornean *Microhyla* (Amphibia, Microhylidae). *Zootaxa*, 2814, 33–49.
- Matsui, M., Hamidy, A., Daicus, M.B., Norhayati, A., Panha, S., Sudin, A., Khonsue, W., Oh, H.-S., Yong, H.-S., Jiang, J.-P. & Nishikawa, K. (2011) Systematic relationships of Oriental tiny frogs of the family Microhylidae (Amphibia, Anura) as revealed by mtDNA genealogy. *Molecular Phylogenetics and Evolution*, 61, 167–176.  
<http://dx.doi.org/10.1016/j.ympev.2011.05.015>
- McKay, J.L. (2006) *A Field Guide to the Amphibians and Reptiles of Bali*. Krieger, Malabar, Florida, 138 pp.
- Shimizu, S. & Ota, H. (2003) Normal development of *Microhyla ornata*: the first description of the complete embryonic and larval stages for the microhylid frogs (Amphibia: Anura). *Current Herpetology*, 22, 73–90.  
<http://dx.doi.org/10.5358/hsj.22.73>
- Savage, J.M. & Heyer, W.R. (1967) Variation and distribution in the tree-frog genus *Phyllomedusa* in Costa Rica, Central America. *Beiträge zur Neotropischen Fauna*, 5, 111–131.  
<http://dx.doi.org/10.1080/01650526709360400>
- Whitten, A.J. & Soeriaatmadja, R.S. (1996) *Ecology of Java & Bali*. Oxford University Press, Oxford, 1004 pp.



# Discordance Between Mitochondrial DNA Genealogy and Nuclear DNA Genetic Structure in the Two Morphotypes of *Rana tagoi tagoi* (Amphibia: Anura: Ranidae) in the Kinki Region, Japan

Koshiro Eto<sup>1</sup>, Masafumi Matsui<sup>1\*</sup>, and Takahiro Sugahara<sup>2</sup>

<sup>1</sup>Graduate School of Human and Environmental Studies, Kyoto University,  
Yoshida Nihonmatsu-cho, Sakyo-ku, Kyoto 606-8501, Japan

<sup>2</sup>Hazama-cho 1740-1, Hachioji, Tokyo 193-0941, Japan

Two morphotypes, with a large and small body size, of a brown frog *Rana t. tagoi* occur sympatrically in the Kinki region, central Honshu of Japan. Previous mitochondrial (mt) DNA genealogical study recognized two main lineages (A and B) and several sublineages in *R. tagoi*, where the small type was placed in the group A-1b, and the large type in groups A-1a and B-2a. Using haplotype network and structure analysis of three nuclear genes, we examined the discrepancy between morphology and mitochondrial genealogy. The results showed that the small type is reproductively isolated from its co-occurring large type (A-1a or B-2a), and that unlimited gene flow occurred between parapatrically occurring two mtDNA lineages of large types (A-1a and B-2a). Discordant genetic relationships between mtDNA and nuclear DNA results may be caused by the past mitochondrial introgression, and possibly, the incomplete lineage sorting. These results also suggest a hetero-specific relationship between the large (A-1a and B-2a) and small types (A-1b). The large type is identified as *Rana t. tagoi* as it is genetically very close to the topotypes of the nominal subspecies, while the small type remains unnamed.

**Key words:** *Rana tagoi*, genealogy, morphotype, mitochondrial DNA, nuclear DNA, introgression, speciation

## INTRODUCTION

A brown frog *Rana tagoi* Okada, 1928 is widely distributed throughout main islands of Japan, except for Hokkaido, and includes three subspecies. However, recent phylogenetic study based on mitochondrial (mt) DNA analysis revealed that *R. tagoi* and its close relative *R. sakuraii* Matsui and Matsui, 1990 are highly divergent genetically with complex evolutionary histories, and include many cryptic taxa (Eto et al., 2012).

In the region of Kinki, central Honshu, two types (large and small types: Sugahara, 1990) of *R. t. tagoi* occur sympatrically and are different in morphology and breeding ecology (Sugahara and Matsui, 1992, 1993, 1994, 1995, 1996, and 1997). Interestingly, the large type is split into two major mitochondrial clades (A and B), one of which (Group A-1a) is more closely related to the small type (Group A-1b) in Clade A, while the other (Group B-2a) was nested in Clade B (Eto et al., 2012).

Mitochondrial (mt) DNA is very widely used in phylogenetic studies, given its high variability and many traits suitable for experiments and analyses (Avise, 2000). However, the results of some recent studies have revealed that phylogenies derived from mtDNA do not always agree with

those obtained from other sources like morphology (e.g., Liu et al., 2010; Hamidy et al., 2011), as is the case in two morphotypes of *R. t. tagoi* described above. Thus, it is desirable to confirm the validity of phylogenetic relationships from mtDNA using other genetic markers.

In order to assess detailed genetic and taxonomic relationships of the two morphotypes with three mitochondrial lineages of *R. t. tagoi* in the Kinki region, we conducted phylogenetic and population genetic analyses using nuclear (n) DNA sequences. By doing this, we tried to infer the states of reproductive isolations among each of the mitochondrial lineages in question.

## MATERIALS AND METHODS

For samples from the Kinki region, we distinguished the large and small types based on body size and other diagnostic characters as described by Sugahara and Matsui (1994). In fact, some samples with mtDNA and morphological traits of the large type showed body sizes intermediate between the two types, but these were treated as the large type.

We first ascertained mtDNA phylogeny of Eto et al. (2012) using 186 samples of *R. t. tagoi* from 41 localities in the Kinki region and nine samples from the type locality in the Chubu region (Fig. 1 and Table. 1). The data include 23 mtDNA sequences from GenBank (accession numbers AB639617, AB639621–AB639630, AB639633–AB639635, AB639706–AB639709, and AB639711–AB639715). We used *R. sauteri* and *R. tsushimensis* (AB685767 and AB639752) as outgroup taxa.

Based on the results of mtDNA analysis, we selected 126 samples from six locality groups of the Kinki region (see result) and nine

\* Corresponding author. Tel. : +81-75-753-6846;  
Fax : +81-75-753-6846;  
E-mail: fumi@zoo.zool.kyoto-u.ac.jp

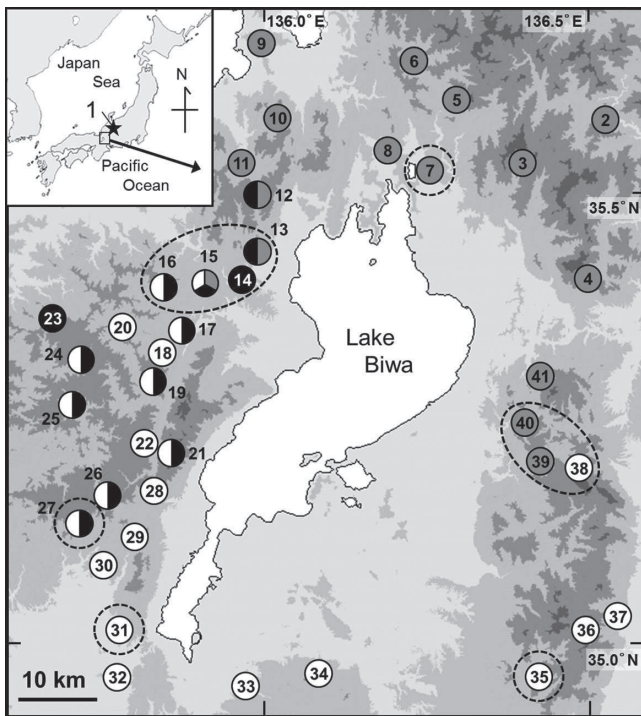

**Fig. 1.** Map of the Kinki region, Japan, showing sampling localities of *Rana t. tagoi*. Open, closed, and shaded circles indicate localities with mitochondrial genetic groups B-2a, A-1b, and A-2a, respectively, and the star shows the type locality in the Chubu region. Ranges encircled by dashed lines indicate localities used in nDNA analyses. Figures indicate localities shown in Table 1.

topotypic samples, and conducted genetic analyses using nDNA sequences. These localities were chosen to represent sites where (1) a single mitochondrial genetic group occurs, (2) two or three groups occur sympatrically, and/or (3) each mitochondrial group occurs parapatrically, exhibiting boundary areas. When samples belonging to different mitochondrial groups co-occurred in a locality, we treated them as different units in the analyses.

Following the experimental conditions and techniques described in Eto et al. (2012), we first analyzed approximately 600 bp of *ND1* (NADH dehydrogenase subunit 1) fragments of mtDNA. We constructed phylogenetic trees based on maximum likelihood (ML) and Bayesian inference (BI). The ML and BI analyses were respectively performed using TREEFINDER ver. Mar. 2011 (Jobb, 2011) and MrBayes v3.2.0 (Ronquist and Huelsenbeck, 2003). Methods for construction of trees also follow Eto et al. (2012). We then amplified partial sequences of three nuclear genes (*NCX1* [sodium-calcium exchanger 1], *POMC* [pro-opiomelanocortin], and *RAG1* [recombination activating gene 1]) by PCR using primer sets listed in Table 2. The experimental conditions and techniques were essentially same as those in mtDNA analysis. We used PHASE ver. 2.1 (Stephens et al., 2001) to separate and determine haplotypes of heterozygous individuals. We considered haplotypes supported by BPP 0.95 or greater as significant; others were treated as missing data.

To estimate relationships between nDNA haplotypes, statistical parsimony networks for each gene were constructed by using TCS version 1.21 (Clement et al., 2000). We also performed population genetic analyses based on nDNA haplotypes. For each population, genetic variability was assessed by calculating the mean observed ( $H_o$ ) and expected ( $H_e$ ) heterozygosities, and all genes were checked with chi-square goodness-of-fit tests to determine whether or not they were deviated from Hardy-Weinberg (HW) equilibrium.

**Table 1.** Numbers and names of sampling localities, assigned mitochondrial genetic groups, and sample sizes of *Rana t. tagoi* examined.

| No.                      | Locality                             | MtDNA group | n  |
|--------------------------|--------------------------------------|-------------|----|
| <i>Rana t. tagoi</i>     |                                      |             |    |
| 1                        | Takayama City, Gifu Pref.            | A-1a        | 9  |
| 2                        | Ibigawa Town, Gifu Pref.             | A-1a        | 1  |
| 3                        | Nagahama City, Shiga Pref.           | A-1a        | 1  |
| 4                        | Maibara City, Shiga Pref.            | A-1a        | 2  |
| 5                        | Nagahama City, Shiga Pref.           | A-1a        | 2  |
| 6                        | Nagahama City, Shiga Pref.           | A-1a        | 2  |
| 7                        | Nagahama City, Shiga Pref.           | A-1a        | 11 |
| 8                        | Nagahama City, Shiga Pref.           | A-1a        | 1  |
| 9                        | Mihama Town, Fukui Pref.             | A-1a        | 1  |
| 10                       | Mihama Town, Fukui Pref.             | A-1a        | 1  |
| 11                       | Mihama Town, Fukui Pref.             | A-1a        | 1  |
| 12                       | Mihama Town, Fukui Pref.             | A-1a        | 1  |
|                          |                                      | A-1b        | 1  |
| 13                       | Takashima City, Shiga Pref.          | A-1a        | 5  |
|                          |                                      | A-1b        | 9  |
| 14                       | Takashima City, Shiga Pref.          | A-1b        | 1  |
| 15                       | Takashima City, Shiga Pref.          | A-1a        | 15 |
|                          |                                      | A-1b        | 2  |
|                          |                                      | B-2a        | 7  |
| 16                       | Takashima City, Shiga Pref.          | A-1b        | 2  |
|                          |                                      | B-2a        | 3  |
| 17                       | Takashima City, Shiga Pref.          | A-1b        | 1  |
|                          |                                      | B-2a        | 1  |
| 18                       | Takashima City, Shiga Pref.          | B-2a        | 7  |
| 19                       | Takashima City, Shiga Pref.          | A-1b        | 2  |
|                          |                                      | B-2a        | 2  |
| 20                       | Takashima City, Shiga Pref.          | B-2a        | 2  |
| 21                       | Otsu City, Shiga Pref.               | A-1b        | 4  |
|                          |                                      | B-2a        | 6  |
| 22                       | Otsu City, Shiga Pref.               | B-2a        | 2  |
| 23                       | Oi Town, Fukui Pref.                 | A-1b        | 1  |
| 24                       | Nantan City, Kyoto Pref.             | A-1b        | 2  |
|                          |                                      | B-2a        | 6  |
| 25                       | Kyoto City, Kyoto Pref.              | A-1b        | 1  |
|                          |                                      | B-2a        | 1  |
| 26                       | Kyoto City, Kyoto Pref.              | A-1b        | 1  |
|                          |                                      | B-2a        | 3  |
| 27                       | Kyoto City, Kyoto Pref.              | A-1b        | 16 |
|                          |                                      | B-2a        | 14 |
| 28                       | Otsu City, Shiga Pref.               | B-2a        | 3  |
| 29                       | Kyoto City, Kyoto Pref.              | B-2a        | 2  |
| 30                       | Kyoto City, Kyoto Pref.              | B-2a        | 1  |
| 31                       | Kyoto City, Kyoto Pref.              | B-2a        | 12 |
| 32                       | Kyoto City, Kyoto Pref.              | B-2a        | 1  |
| 33                       | Otsu City, Shiga Pref.               | B-2a        | 1  |
| 34                       | Konara City, Shiga Pref.             | B-2a        | 1  |
| 35                       | Koka City, Shiga Pref.               | B-2a        | 9  |
| 36                       | Higashiomi City, Shiga Pref.         | B-2a        | 1  |
| 37                       | Komono Town, Mie Pref.               | B-2a        | 1  |
| 38                       | Taga Town, Shiga Pref.               | B-2a        | 5  |
| 39                       | Taga Town, Shiga Pref.               | A-1a        | 1  |
| 40                       | Taga Town, Shiga Pref.               | A-1a        | 5  |
| 41                       | Maibara City, Shiga Pref.            | A-1a        | 2  |
| <i>Rana tsushimensis</i> |                                      |             |    |
|                          | Tsushima City, Nagasaki Pref., Japan |             | 1  |
| <i>Rana sauteri</i>      |                                      |             |    |
|                          | Alishan, Chiayi Country, Taiwan      |             | 1  |

**Table 2.** Primers used to amplify nuclear genes in this study.

| Target | Name           | Sequence                      | Reference             |
|--------|----------------|-------------------------------|-----------------------|
| NCX1   | NCX1F          | ACAACAGTRAGRATATGGAA          | Shimada et al. (2011) |
|        | NCX1R1         | GCCATATCTCTCCTCGCTTCTTC       | This study            |
| POMC   | POMC1          | GAATGTATYAAAGMMTGCAAGATGGWCCT | Wiens et al. (2005)   |
|        | POMC7          | TGGCATTITTTGAAAAGAGTCAT       | Smith et al. (2005)   |
| RAG1   | Rag-1 Meristo1 | CAGTTCCTGAGAAAGCAGTACG        | Shimada et al. (2008) |
|        | Rag-1 Meristo2 | GGCTTTGCTGAAACTCCTTTC         | Shimada et al. (2008) |

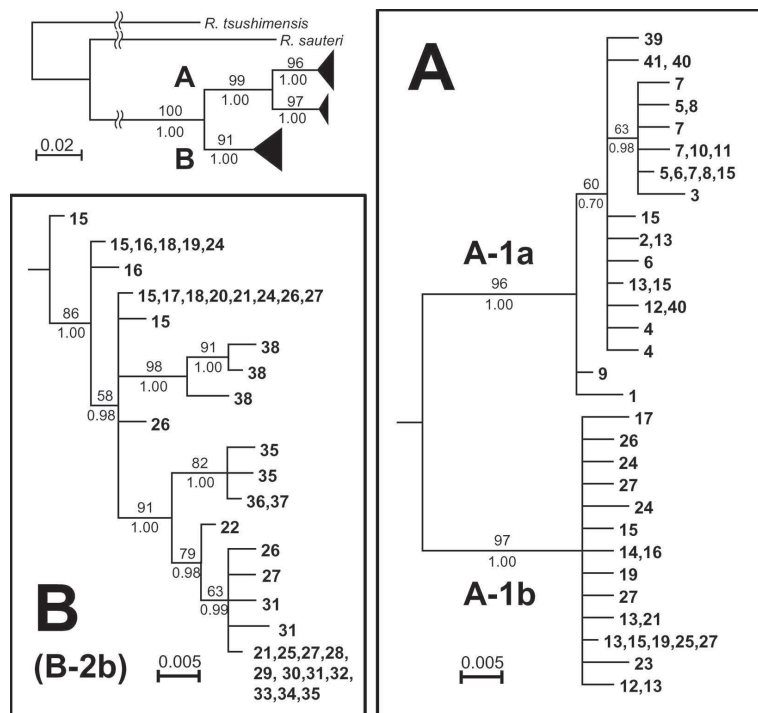
**Fig. 2.** Bayesian tree of mitochondrial ND1 gene for *Rana t. tagoi* and outgroup taxa. Nodal values indicate bootstrap supports for ML (above) and Bayesian posterior probability (below). For locality information, see Table 1 and Fig. 1.

All these analyses were conducted by using GENALEX 6.41 (Peakall and Smouse, 2006). To estimate population genetic structure, we used STRUCTURE ver. 2.3.3 (Pritchard et al., 2000) with admixture model. The most likely number of clusters was estimated according to the delta K value (Evanno et al., 2005).

## RESULTS

### Phylogenetic relationships based on mtDNA sequences

We obtained 564 bp of the mitochondrial ND1 gene for all samples, and after combining identical sequences, total 51 sequences were used in the subsequent analysis. Within ingroup sequences, 83 variable sites (vs) and 55 parsimony-informative sites (pi) were included. Newly obtained sequences were deposited in GenBank (AB779781-AB779812). The best substitution models estimated by Kakusan 4 (Tanabe, 2011) for ML and BI were J1 model (Jobb, 2011) with a gamma shape parameter (G) and Hasegawa-Kishino-Yano-1985 (HKY85) + G, respectively.

Phylogenetic analyses based on ML and BI yielded essentially identical topologies ( $-\ln L = 2029.55$  and  $2290.28$ , respectively), and only BI tree is shown in Fig. 2. Just same as already reported (Eto et al., 2012), the ingroup was

divided into three clades corresponding to Groups A-1a (ML-BS = 97% and BPP = 1.00, respectively), A-1b (96% and 1.00), and B-1a (91% and 1.00) of Eto et al. (2012). Groups A-1a and A-1b formed a clade (99% and 1.00) with closer genetic similarity in between (mean p-distance = 3.7%) than

to B-2a (p-distance between A-1a = 6.7% and between A-1b = 6.5%).

Geographically, Groups A-1a and B-2a of the large type occurred parapatrically, with the former distributed in northeastern part and the latter in southwestern part of the sampling area. In contrast, distribution of the small type Group A-1b samples largely overlapped with them in the western side of Lake Biwa (Fig. 1).

### Genetic variations in nuclear genes

Samples selected for nDNA analyses were 126 from six locality groups, consisting of localities (Locs.) 7, 13–16, 27, 31, 35, and 38–40 (Fig. 1), and nine topotypic ones from Loc. 1. Among them, a single mitochondrial genetic group was recognized in Locs. 1 (A-1a), 7 (A-1a), 31 (B-2a), and 35 (B-2a), and two groups occurred sympatrically in Loc. 27 (A-1b and B-2a). The boundary areas of multiple groups were located in 13–16 (A-1a and B-2a, with sympatric samples of A-1b) and 38–40 (A-1a and B-2a). For subsequent analyses, we differentiated these mitochondrial lineages in a given locality group (Table 3).

After a haplotype reconstruction using PHASE ver. 2.1, we obtained a total of 13 haplotypes (“a” to “m” in Fig. 3A) in *NCX1* (535 bp; vs = 14, pi = 8), 23 haplotypes (“a” to “w” in Fig. 3B) in *POMC* (552 bp; vs = 24, pi = 12), and 13 haplotypes (“a” to “m” in Fig. 3C) in *RAG1* (454 bp; vs = 14, pi = 11). Each haplotype was deposited in GenBank (AB779768-AB779780, AB779813-AB779848). In some samples (two in *NCX1*, one in *POMC*, and 11 in *RAG1*), we could not reconstruct their haplotypes with significant support (< 0.95). Thus we omitted these samples in the haplotype network analyses, although we used them in the structure analysis by applying missing data value.

Haplotype networks and frequencies of each gene are shown in Fig. 3 and Table 3, respectively. Two haplotype groups were recognized in the network of *NCX1* (Fig. 3A): one of them mainly consisted of the haplotypes specific to samples belonging to Group A-1a and B-2a (e.g., haplotypes “a” and “b”), and another one mainly consisted of haplotypes specific to Group A-1b (e.g., “l” and “m”). The haplotype network of *POMC* (Fig. 3B) also included several haplotype groups, which exhibited following tendencies: haplotypes specific to or frequently observed in Group A-1b samples (e.g., haplotypes “v” and “w”) tended to form a group; haplotypes frequently observed in A-1a and B-2a samples from Locs. 7, 13–16, 27, and 31 (e.g., “a” and “c”) tended to form a group; topotypic samples from Loc. 1 pos-

**Table 3.** Haplotype frequencies and genetic variabilities at three nuclear genes (*NCX1*, *POMC*, and *RAG1*) among localities and mitochondrial genetic groups of *Rana t. tagoi*. For locality numbers, see Fig. 1 and Table 1.

| Loc. | 1     |        | 7      |        | 13–16  |        |        | 27     |        | 31     | 35     | 38–40  |  |
|------|-------|--------|--------|--------|--------|--------|--------|--------|--------|--------|--------|--------|--|
|      | MtDNA | A-1a   | A-1a   | A-1a   | A-1b   | B-2a   | A-1b   | B-2a   | B-2a   | B-2a   | A-1a   | B-2a   |  |
|      | n     | 9      | 11     | 20     | 14     | 10     | 16     | 14     | 12     | 9      | 6      | 5      |  |
| NCX1 |       | a0.722 | a0.455 | a0.342 | h0.036 | a0.300 | b0.031 | a0.731 | a1.000 | a1.000 | a0.583 | a0.900 |  |
|      |       | c0.111 | b0.091 | b0.526 | j0.036 | b0.650 | h0.031 | b0.269 |        |        | g0.250 | h0.100 |  |
|      |       | f0.056 | c0.227 | c0.079 | k0.250 | c0.050 | i0.031 |        |        |        | h0.167 |        |  |
|      |       | m0.111 | f0.091 | d0.026 | l0.071 |        | l0.281 |        |        |        |        |        |  |
|      |       |        | h0.136 | e0.026 | m0.607 |        | m0.625 |        |        |        |        |        |  |
|      | Ho    | 0.556  | 0.727  | 0.632  | 0.429  | 0.300  | 0.467  | 0.538  | –      | –      | 0.667  | 0.200  |  |
| POMC |       | a0.056 | a0.250 | a0.700 | a0.071 | a0.591 | c0.063 | a0.821 | a0.375 | a0.300 | a0.083 | a0.100 |  |
|      |       | c0.611 | c0.250 | b0.075 | t0.071 | b0.227 | s0.094 | c0.179 | c0.208 | j0.350 | j0.333 | j0.400 |  |
|      |       | q0.278 | f0.150 | c0.100 | u0.071 | c0.091 | y0.156 |        | o0.083 | m0.200 | l0.333 | k0.200 |  |
|      |       | r0.065 | g0.100 | d0.075 | v0.214 | e0.045 | v0.438 |        | p0.333 | o0.100 | m0.167 | l0.100 |  |
|      |       |        | h0.100 | e0.050 | w0.571 | v0.045 | w0.250 |        |        | v0.050 | n0.083 | m0.200 |  |
|      |       |        | i0.050 |        |        |        |        |        |        |        |        |        |  |
|      |       | j0.050 |        |        |        |        |        |        |        |        |        |        |  |
|      |       | v0.050 |        |        |        |        |        |        |        |        |        |        |  |
| Ho   | 0.667 | 0.900  | 0.500  | 0.571  | 0.700  | 0.867  | 0.214  | 0.750  | 0.667  | 0.833  | 0.600  |        |  |
| He   | 0.543 | 0.825  | 0.486  | 0.612  | 0.570  | 0.700  | 0.293  | 0.698  | 0.716  | 0.736  | 0.740  |        |  |
| RAG1 |       | a0.214 | a0.250 | a0.575 | a0.167 | a0.650 | a0.344 | a0.179 | a0.045 | b0.118 | a0.250 | b0.125 |  |
|      |       | b0.429 | b0.250 | b0.150 | b0.208 | b0.100 | b0.063 | b0.643 | b0.409 | c0.294 | g0.500 | c0.125 |  |
|      |       | f0.286 | d0.063 | c0.050 | j0.042 | c0.050 | j0.063 | m0.179 | c0.182 | d0.176 | h0.167 | g0.375 |  |
|      |       | m0.071 | f0.250 | d0.100 | l0.125 | f0.100 | k0.031 |        | i0.045 | g0.176 | m0.083 | h0.375 |  |
|      |       |        | j0.063 | e0.025 | m0.458 | i0.050 | l0.156 |        | m0.318 | h0.118 |        |        |  |
|      |       |        | m0.125 | j0.050 |        | m0.050 | m0.344 |        |        | m0.118 |        |        |  |
|      |       |        | m0.050 |        |        |        |        |        |        |        |        |        |  |
| Ho   | 0.571 | 0.750  | 0.684  | 0.500  | 0.600  | 0.800  | 0.500  | 0.727  | 0.875  | 0.833  | 0.500  |        |  |
| He   | 0.684 | 0.789  | 0.597  | 0.701  | 0.550  | 0.720  | 0.523  | 0.694  | 0.820  | 0.653  | 0.688  |        |  |

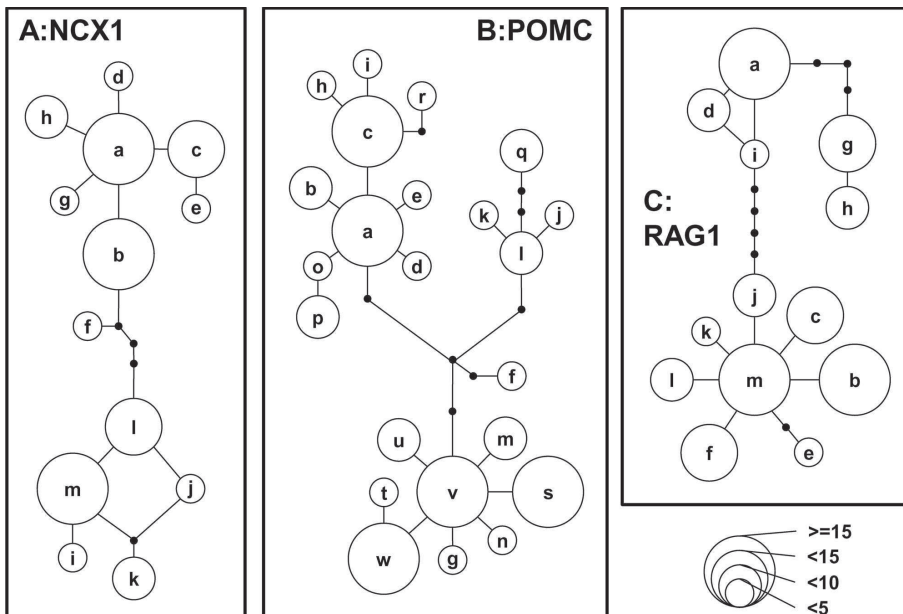

**Fig. 3.** Statistical parsimony networks of (A) *NCX1*, (B) *POMC*, and (C) *RAG1* haplotypes of *Rana t. tagoi* from northeastern Kinki region and type locality. Filled circles indicate missing haplotypes. The size of each open circle is proportional to the haplotype frequency.

essed some unique haplotypes (“q” and “r”), although they largely shared haplotypes (“a” and “c”) with A-1a and B-2a samples from the other localities. The haplotype network of

*RAG1* (Fig. 3C) included three distinct haplotype groups that did not clearly match the groupings by either mitochondrial genealogy or geographic distribution, but weakly showed the following tendencies: haplotypes frequently observed in samples of Group B-2a from Locs. 27 and 31, and A-1b (e.g., haplotypes “b” and “m”) tended to form a group, which also included several haplotypes from other mitochondrial groups or localities; haplotypes specific to samples of A-1a and B-2a from Locs. 35 and 38–40 (“g” and “h”) formed a group.

Statistics on the genetic variability of mitochondrial groups from each locality are shown in Table 3. No significant deviation from HW expectations was observed in each gene/locality. The structure analysis was performed for up to  $k = 10$ , and resultant barplots for  $k = 2$  to 4 are shown in Fig. 4. The likelihood values reached a plateau

after  $k = 2$ , and the estimated delta K value was highest at  $k = 2$  (data not shown). At  $k = 2$ , two clusters, one including mitochondrial Groups A-1a and B-2a and another corre-

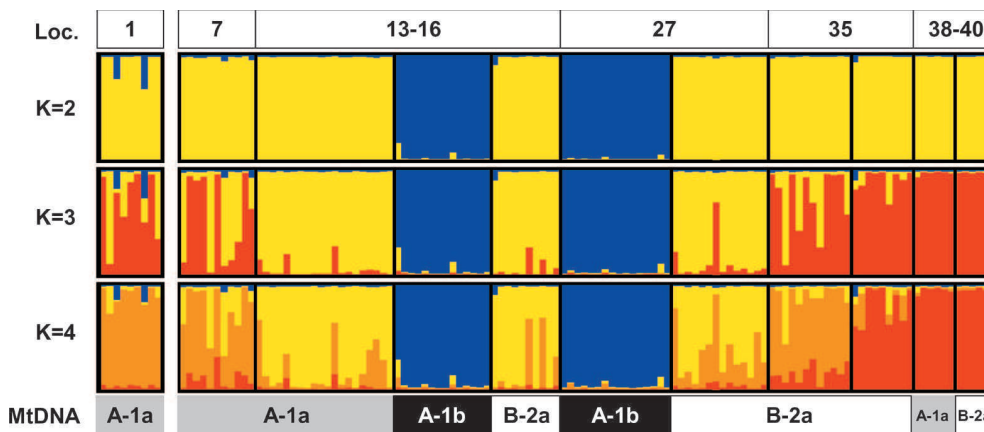

**Fig. 4.** Assigned genetic clusters of 135 individuals of *R. t. tagoi* from six locality groups in the Kinki and the type locality by structure analysis ( $k = 2-4$ ). For locality numbers, see Fig. 1 and Table 1.

sponding to Group A-1b were recognized. At  $k = 3$ , the cluster of A-1a + B-2a at  $k = 2$  was further divided into two clusters, but the division did not support the separation of two mitochondrial groups. Based on the test of delta  $K$  and clustering patterns of each bar plot, the most plausible number of clusters was considered to be two, by which the large type (mitochondrial Groups A-1a and B-2a) and the small type (mitochondrial Group A-1b) were split.

## DISCUSSION

### Discordance of estimated relationships among genetic markers

As in our previous report (Eto et al., 2012), the results of phylogenetic analyses based on mtDNA did not support morphological delimitation of *R. t. tagoi* from the Kinki region. Obtained genealogy showed that the *R. t. tagoi* large type was not monophyletic, and was split into two highly differentiated lineages. In contrast, the results of nDNA analyses did not support such a mitochondrial relationship, but were congruent with morphological delimitation.

Discordance of results between mt- and n-DNA analyses could be explained by mitochondrial incomplete lineage sorting (ILS) or gene introgression derived from past hybridization among ancestral lineages (Avice, 2000; Ballard and Whitlock, 2004). Because lineage sorting normally progresses rapidly in mtDNA, ILS of mtDNA is rare compared to that of nDNA (Ballard and Whitlock, 2004). However, lineages of *R. tagoi* are thought to have diverged recently from their relatively small genetic divergences (Eto et al., 2012), and therefore the possibility of mtDNA ILS, even at the species level, is not completely rejected (e.g., as a product of budding speciation: Funk and Omland, 2003). In this scenario, the ancestor of the *R. t. tagoi* small type (A-1b) originated as an internal lineage of the large type (A-1a and B-2a). The ancestral populations of A-1b subsequently underwent morphological and ecological differentiation toward the smaller body size, while ancestral A-1a and B-2a populations retained their larger body size.

On the other hand, past mitochondrial introgression among ancestors of each lineage can also explain the discordance of mtDNA and nDNA properties. Based on this hypothesis, hybridization between the ancestral populations

of A-1b (or other Clade A lineages) and B-2a had occurred in past, resulting in mtDNA introgression from the former to the latter. After the introgression event, mtDNA in the ancestral populations of B-2a, A-1b, and the introgressed populations of B-2a (ancestral A-1a) independently experienced mutations and resulted in the formation of present relationships.

Mitochondrial ILS and past gene introgression are often difficult to distinguish (Ballard and Whitlock, 2004; Funk and Omland, 2003). In

our case, if ILS caused the discordance, the small type (A-1b) should be genetically close to one of the large type lineages (A-1a) not only in mtDNA, but also in nDNA. However, our results actually did not support close relationship of A-1a and A-1b in nDNA, thus not favoring ILS. Nonetheless, however, the ILS scenario may be supported by male-biased gene flow. In such a case, the original nuclear haplotypes and genetic structure of A-1a would have been similar to those of A-1b, but were completely overwritten via male-biased gene flow with B-2a. However, nDNA is fundamentally less likely to be introgressive than mtDNA, and no behavioral data for male-biased dispersal in this species are available at present. Compared with the ILS hypothesis, the past mtDNA introgression hypothesis is less problematic and is considered more plausible.

In addition to discordance of mt- and n-DNA, each nuclear gene also showed more or less discordant patterns on their haplotype networks. Among three nuclear genes, only *NCX1* showed obvious relationships between the haplotype network and the morphotype. This result suggests that the ILS of the remaining two genes (*POMC* and *RAG1*) may have caused discordance among nuclear genes. These results seem to indicate that phylogenetic analyses using direct sequences of nuclear genes may be not efficient in the study of *R. tagoi*, and that population genetic analyses based on frequency data of nuclear genotypes may be more effective (Avice, 2000).

### Taxonomic status of two morphotypes of *Rana t. tagoi*

Sympatric occurrence of two types of *Rana t. tagoi* was first reported from Kyoto Prefecture in the Kinki region by Sugahara (1990). Later, Sugahara and Matsui (1992, 1993, 1994, 1995, 1996, and 1997) performed morphological, acoustic, and ecological comparisons, and suggested that these two types were not conspecific, being reproductively isolated from each other. Subsequent genetic survey using mtDNA (Tanaka et al., 1994) clarified remarkably large genetic divergences between the large (corresponding to B-2a in this paper) and the small (A-1b) types from Kyoto. Furthermore, Eto et al. (2012) showed that the large type was further divided into two genetic lineages (A-1a and B-2a), although they were morphologically similar. Eto et al. (2012)

also confirmed that one of them (A-1a) was phylogenetically close to the small type (A-1b). Present result of mtDNA analysis supported these previous studies.

In contrast, our nDNA analyses suggested a closer relationship of A-1a to B-2a than to A-1b. Our structure analysis indicated unlimited gene flow between A-1a and B-2a, and the existence of genetic isolation of A-1b from sympatric A-1a or B-2a was also suggested. These results are congruent with previous results of morphological and ecological studies (Sugahara and Matsui, 1992, 1993, 1994, 1995, 1996, 1997), which indicated that the *R. t. tagoi* large type (A-1a and B-2a) and the small type (A-1b) from the Kinki region are specifically distinct.

In our nDNA analyses, the large type was genetically also close to topotypes of *R. t. tagoi* that have body size intermediate between the large and small groups. These facts suggest that the large type is in fact conspecific with the topotypes, and should be treated as true *R. t. tagoi*, while the small type is a distinct but unnamed species. The reason for the presence of size variation within true *R. t. tagoi* (the large and the medium type) is unknown, but may be related to the sympatry of the large type with the small type (Sugahara and Matsui, 1996), unlike singly occurring medium type.

#### ACKNOWLEDGMENTS

We thank S. Ajitani, A. Hamidy, M. Hayashi, T. Hikida, M. Kato, K. Kawachi, N. Kuraishi, Mt. Matsui, T. Matsuki, Y. Misawa, A. Mori, S. Mori, N. Nakahama, T. Nakano, Y. Nakase, K. Nishikawa, T. Ogue, T. Shimada, T. Sugihara, H. Takeuchi, S. Tanabe, T. Tanaka-Ueno, A. Tominaga, and N. Yoshikawa for collecting specimens. N. Kuraishi and N. Yoshikawa also assisted with experiments. We are also grateful to two anonymous reviewers for valuable comments on the manuscript. This work was partly supported by grants from the Ministry of Education, Science and Culture, Japan (Nos. 07454234, 20405013 and 23405014) to MM.

#### REFERENCES

- Avice JC (2000) Phylogeography: The History and Formation of Species. Harvard University Press, Cambridge, Massachusetts
- Ballard JWO, Whitlock MC (2004) The incomplete natural history of mitochondria. *Mol Ecol* 13: 729–744
- Clement M, Posada D, Crandall KA (2000) TCS: a computer program to estimate gene genealogies. *Mol Ecol* 53: 781–792
- Eto K, Matsui M, Sugahara T, Tanaka-Ueno T (2012) Highly complex mitochondrial DNA genealogy in an endemic Japanese subterranean breeding brown frog *Rana tagoi* (Amphibia, Anura, Ranidae). *Zool Sci* 29: 662–671
- Evanno G, Regnaut S, Goudet J (2005) Detecting the number of clusters of individuals using the software STRUCTURE: a simulation study. *Mol Ecol* 14: 2611–2620
- Funk DJ, Omland KE (2003) Species-level paraphyly and polyphyly: frequency, causes, and consequences, with insights from animal mitochondrial DNA. *Annu Rev Ecol Syst* 34: 397–423
- Hamidy A, Matsui M, Shimada T, Nishikawa K, Yambun P, Sudin A, et al. (2011) Morphological and genetic discordance in two species of Bornean *Leptobrachium* (Amphibia, Anura, Megophryidae). *Mol Phylogenet Evol* 61: 904–913
- Jobb G (2011) TREEFINDER version of March 2011. Munich, Germany. Distributed by the author at [www.treefinder.de](http://www.treefinder.de)
- Liu K, Wang F, Chen W, Tu L, Min M, Bi K, et al. (2010) Rampant historical mitochondrial genome introgression between two species of green pond frogs, *Pelophylax nigromaculatus* and *P. plancyi*. *BMC Evol Biol* 10: 201
- Peakall R, Smouse PE (2006) GENALEX 6: genetic analysis in Excel. Population genetic software for teaching and research. *Mol Ecol Notes* 6: 288–295
- Pritchard JK, Stephens M, Donnelly P (2000) Inference of population structure using multilocus genotype data. *Genetics* 155: 945–959
- Rambaut A, Drummond AJ (2009) Tracer version 1.5. Available at <http://tree.bio.ed.ac.uk/software/tracer>
- Ronquist FR, Huelsenbeck JP (2003) MrBayes 3: Bayesian phylogenetic inference under mixed models. *Bioinformatics* 19: 1572–1574
- Shimada T, Matsui M, Yambun P, Lakim M, Maryati M (2008) Detection of two cryptic taxa in *Meristogenys amoropalamus* (Amphibia, Ranidae) through nuclear and mitochondrial DNA analyses. *Zootaxa* 1843: 24–34
- Shimada T, Matsui M, Yambun P, Sudin A (2011) A taxonomic study of Whitehead's torrent frog, *Meristogenys whiteheadi*, with descriptions of two new species (Amphibia: Ranidae). *Zool J Linn Soc* 161: 157–183
- Stephens M, Smith N, Donnelly P (2001) A new statistical method for haplotype reconstruction from population data. *Am J Hum Gen* 68: 978–989
- Sugahara T (1990) Reproductive ecology of *Rana tagoi tagoi* at Kitayama in Kyoto. *Jpn J Herpetol* 13: 145
- Sugahara T, Matsui M (1992) Larval growth and development in two types of the Japanese brown frog, *Rana tagoi tagoi*, at Kumogahata, Kyoto. *Jpn J Herpetol* 14: 209
- Sugahara T, Matsui M (1993) Morphometric comparisons in two types of *Rana t. tagoi* from Kumogahata, Kyoto. *Jpn J Herpetol* 15: 83
- Sugahara T, Matsui M (1994) An investigation of characters that discriminate two morphotypes of *Rana tagoi tagoi*. *Jpn J Herpetol* 15: 151
- Sugahara T, Matsui M (1995) Acoustic comparisons in two types of *Rana t. tagoi* from Kumogahata, Kyoto. *Jpn J Herpetol* 16: 64–65
- Sugahara T, Matsui M (1996) Morphological variation in *Rana tagoi* from regions around Kinki. *Jpn J Herpetol* 16: 151–152
- Sugahara T, Matsui M (1997) Breeding seasons and sites in two types of *Rana tagoi tagoi* from Kumogahata, Kyoto. *Jpn J Herpetol* 17: 68–69
- Tanabe AS (2011) Kakusan4 version 4.0.2011.05.28. Software distributed by the author at <http://www.fifthdimension.jp/products/kakusan>
- Wiens J, Fetzner JW Jr, Parkinson CL, Reeder TW (2005) Hylid frog phylogeny and sampling strategies for speciose clades. *Syst Biol* 54: 719–748

(Received January 18, 2013 / Accepted February 28, 2013)