

Zeta functions
over zeros of **Zeta functions**
and an exponential-asymptotic view
of the Riemann Hypothesis

dedicated to Professor Takashi AOKI for his 60th birthday

By

André VOROS*

Abstract

We review generalized zeta functions built over the Riemann zeros (in short: “superzeta” functions). They are symmetric functions of the zeros that display a wealth of explicit properties, fully matching the much more elementary Hurwitz zeta function. As a concrete application, a superzeta function enters an integral representation for the Keiper–Li coefficients, whose large-order behavior thereby becomes computable by the method of steepest descents; then the dominant saddle-point entirely depends on the Riemann Hypothesis being true or not, and the outcome is a sharp exponential-asymptotic criterion for the Riemann Hypothesis that only refers to the large-order Keiper–Li coefficients. As a new result, that criterion, then Li’s criterion, are transposed to a novel sequence of Riemann-zeta expansion coefficients based at the point $1/2$ (vs 1 for Keiper–Li).

It is a great honor and pleasure to dedicate this work to Professor AOKI, who has had zeta functions among his numerous activities; we are specially grateful to him for setting up a major conference in Osaka in 2003 [1] that much stimulated our work afterwards. And the present work also touches another theme in which we have much longer fruitfully interacted with him (and collaborators, mainly at the RIMS), namely complex exponential asymptotics (here embodied in the method of steepest descents).

Received March 26, 2014. Accepted June 13, 2014.

2010 Mathematics Subject Classification(s): 11-02, 11-06, 11M26, 11M41, 11M35, 30B40, 30E15, 41A60.

Key Words: Riemann zeta function, Riemann zeros, superzeta functions, special values, Mellin transforms, Stieltjes constants, Li criterion.

*Institut de Physique Théorique, CEA-Saclay (CNRS-URA 2306), F-91191 Gif-sur-Yvette Cedex, France. e-mail: andre.voros@cea.fr

§ 1. (Generalized) zeta functions

Discrete numerical sets $\{w_k\}$ that have “natural”, “collective” definitions (e.g., roots of equations, spectra, ...), are often better accessible through their *symmetric functions*, which easily display richer and more explicit properties than the initial data. Specially fruitful symmetric functions turn out to be the *zeta functions*, defined (formally) as

$$(1) \quad Z(x) = \sum_k w_k^{-x} \quad (\text{standard zeta}), \quad Z(x, w) = \sum_k (w_k + w)^{-x} \quad (\text{generalized zeta}),$$

typically for complex arguments. As a rule, the exponent (here, x) is the key variable; the shift parameter (w) adds useful flexibility but retains an auxiliary status.

Based on [31] and references therein, we will specifically review cases where $\{w_k\}$ is the set of nontrivial zeros $\{\rho\}$ of Riemann’s zeta function (or some related set, or a generalization) - we will name the resulting functions (1) “superzeta” functions for brevity.

Our starting set $\{w_k\}$ will however be the natural integers, with the zeta functions

$$(2) \quad \zeta(x) = \sum_{k=1}^{\infty} k^{-x} \quad (\text{Riemann}), \quad \zeta(x, w) = \sum_{k=0}^{\infty} (k + w)^{-x} \quad (\text{Hurwitz}) \quad (\text{Re } x > 1)$$

(the standard notations, in which $\zeta(x) \equiv \zeta(x, w = 1)$), because

- a) $\zeta(x)$ gives rise to the first superzeta functions, those over the *Riemann zeros*;
- b) $\zeta(x, w)$ provides the basic *template* for the full set of explicit properties ultimately displayed by those less elementary superzeta functions.

§ 1.1. Predicted pattern of general results for zeta functions

For our later sets $\{w_k\}$ (all countably *infinite*), typical results can be categorized as:

- **A - Analytic structure in the whole complex x -plane** (at fixed w): our zeta functions will be defined by (1) only over a half-plane in x , as in (2), but will then admit a *meromorphic* continuation to the whole x -plane, with *exactly and fully computable poles and principal parts*. (E.g., Hurwitz’s $\zeta(x, \cdot) = 1/(x - 1) + [\text{entire function}]$.)
- **F - Functional relation** (often): this may link the analytic continuation of $Z(x, w)$ to another function of Mellin-transform type (as in (10) for the Hurwitz case); when it exists, **F** may also readily supply all the explicit features announced here.
- $\frac{\mathbf{R}}{\mathbf{T}}$ - **Special-value formulae** for $Z(x, w)$ at all integers $x = \mp n$: $\frac{\mathbf{Rational}}{\mathbf{Transcendental}}$ respectively (such will be the layout of the Tables), and having quite distinct origins:

R for $x = -n$ (in conjunction with **A**): our zeta functions relate to *Mellin transforms*, e.g., $Z(x, w) = \Gamma(x)^{-1} \int_0^\infty f(z, w) z^{x-1} dz$ (like (7) for Hurwitz) where $f(z, w)$ will have an explicit $z \rightarrow 0$ power expansion: this feature makes the Mellin integral meromorphic for all x by continuation and also yields its explicit poles and principal parts (**A**), plus (upon the division by $\Gamma(x)$) explicit **rational (R)** values for $Z(x, w)$ at all $x = -n$ (*0 and the negative integers*). By “rational” we mean: polynomial in w and in the expansion coefficients of f at $z = 0$.

T for $x = +n$: zeta functions relate to zeta-regularized products $D(w) = \prod_k (w + w_k)$ by

$$(3) \quad \log D(w) \stackrel{\text{def}}{=} -\partial_x Z(x, w)|_{x=0} \quad \text{for } Z(x, w) = \sum_k (w_k + w)^{-x}$$

$$(4) \quad \implies \quad Z(n, w) = \frac{(-1)^{n-1}}{(n-1)!} (\log D)^{(n)}(w) \text{ for } n = 1, 2, \dots \quad \text{outside poles of } Z,$$

$$(5) \text{ vs } \left\{ \begin{array}{l} \text{FP}_{x=1} Z(x, w) = (\log D)'(w) \quad (\text{FP: finite-part extraction}) \\ \text{FP}_{x=n} Z(x, w) = [\text{a bulkier formula}] \text{ for } n \geq 2 \text{ [31, § 2.6.1]} \end{array} \right\} \text{ on poles of } Z$$

(the very last case has no use here); thus, formulae (3)–(5) express zeta values at all $x = +n$ (0 and the positive integers), in terms of a function $D(w)$ which is entire, has $\{-w_k\}$ as zeros, and will be **transcendental (T)** but hopefully known. E.g., in the Hurwitz case: $\{w_k\} = \{0, 1, 2, \dots\}$ leads to

$$(6) \quad D(w) = \sqrt{2\pi}/\Gamma(w).$$

§ 1.2. Results for the Hurwitz zeta function $\zeta(x, w)$

We recall classic results [9], to be needed for the notations and for later reference.

• **F**- Functional relation (will imply **A**): we start from the (obvious) Mellin-transform representation of $\zeta(x, w)$, then convert it to a Hankel integral:

$$(7) \quad \zeta(x, w) = \frac{1}{\Gamma(x)} \int_0^\infty \frac{e^{(1-w)z}}{e^z - 1} z^{x-1} dz \quad (\text{Re } x > 1, \text{ Re } w > 0)$$

$$(8) \quad = \frac{\Gamma(1-x)}{2i\pi} \int_{C'} \frac{e^{(1-w)z}}{e^z - 1} (-z)^{x-1} dz \quad (x \notin \mathbb{N}^*, 1 \geq \text{Re } w > 0)$$

$$(9) \quad = \frac{\Gamma(1-x)}{2i\pi} \lim_{R \rightarrow +\infty} \int_{C_R} \frac{e^{(1-w)z}}{e^z - 1} (-z)^{x-1} dz \quad (x \notin \mathbb{N}^*, 1 \geq \text{Re } w > 0)$$

(see Fig. 1); then this contour integral is readily evaluated by the residue calculus, giving

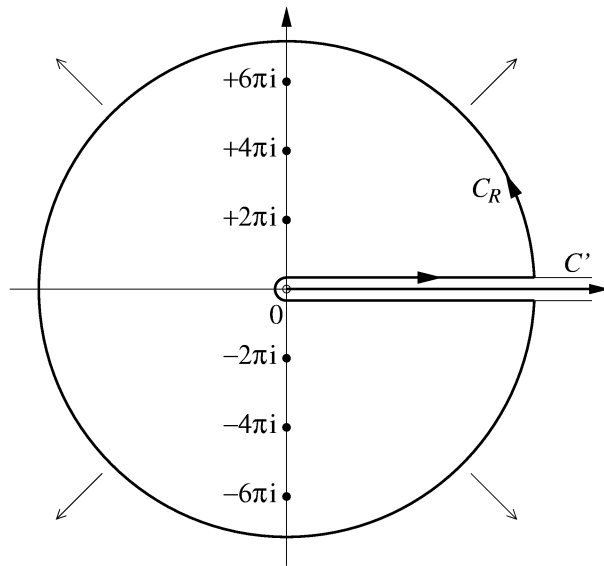

Figure 1. Integration paths in (8)–(9) leading to the functional relation (10) for $\zeta(x, w)$.

$$(10) \quad \zeta(x, w) = \frac{\Gamma(1-x)}{(2\pi)^{1-x} i} [e^{i\pi x/2} F(e^{2i\pi w}, 1-x) - e^{-i\pi x/2} F(e^{-2i\pi w}, 1-x)] \quad (\mathbf{F})$$

$$(11) \quad \text{for } F(u, y) \stackrel{\text{def}}{=} \sum_{n=1}^{\infty} \frac{u^n}{n^y}, \quad \text{and } \text{Re } x < 0, 1 \geq \text{Re } w > 0 \quad (\mathbf{A})$$

(Lerch or polylogarithm function; (10): Jonquière’s formula).

- $\frac{\mathbf{R}}{\mathbf{T}}$ - Special values: \mathbf{R} resulting from (7), followed by \mathbf{T} from (6), are listed in Table 1.

x	$\zeta(x, w) = \sum_{k=0}^{\infty} (k+w)^{-x}$	
$-n \leq 0$	$-\frac{1}{n+1} B_{n+1}(w)$	
0	$\frac{1}{2} - w$	\mathbf{R}
0 (<i>x-derivative</i>)	$\zeta'(0, w) = \log(\Gamma(w)/\sqrt{2\pi})$	\mathbf{T}
$+1$ (<i>finite part</i>)	$\text{FP}_{x=1} \zeta(x, w) = -(\log \Gamma)'(w)$	
$+n > 1$	$\frac{(-1)^n}{(n-1)!} (\log \Gamma)^{(n)}(w)$	

Table 1. Special-value formulae for the Hurwitz zeta function, $\frac{\text{Rational}}{\text{Transcendental}}$ at all integer $x = \mp n$. ($B_n(w)$: Bernoulli polynomials.)

Moreover, (10) reduces at $w = 1$ to *Riemann's Functional Equation*:

$$(12) \quad \zeta(x) \equiv 2(2\pi)^{x-1} \sin \frac{\pi x}{2} \Gamma(1-x) \zeta(1-x) \iff \Xi(\tfrac{1}{2} + t) \equiv \Xi(\tfrac{1}{2} - t),$$

in terms of a *completed* zeta function

$$(13) \quad \Xi(x) = x(x-1)\pi^{-x/2}\Gamma(x/2)\zeta(x) \quad (\text{our normalization: } \Xi(0) = \Xi(1) = 1),$$

and of the convenient variable $t \equiv x - \frac{1}{2}$. Remarkable values of t are then

$$t = 0 \text{ (the center of symmetry for } \Xi(\tfrac{1}{2} + \cdot)) \quad \text{and} \quad t = +\tfrac{1}{2} \text{ (the pole of } \zeta(\tfrac{1}{2} + \cdot)).$$

Due to (12), $\zeta(x)$ has *trivial zeros*: $x = -2k$, $k = 1, 2, \dots$, plus those of $\Xi(x)$: the *Riemann zeros* ρ ; the latter are countably many, 2-by-2 symmetrical about $t = 0$, as

$$(14) \quad \rho = \tfrac{1}{2} \pm i\tau_k \quad (\text{Re } \tau_k > 0) \quad (k = 1, 2, \dots),$$

and lie within the *critical strip* $\{0 < \text{Re } \rho < 1\}$; moreover, the *Riemann Hypothesis* [24] (still an open conjecture) puts them all on the *critical line*:

$$(15) \quad \text{Re } \rho = \tfrac{1}{2} \iff \tau_k \text{ is real} \quad \text{for all Riemann zeros.} \quad \mathbf{[RH]}$$

§ 2. Superzeta functions, in the Riemann zeros' case

Over the set of Riemann zeros $\{\rho\}$ (always counted with multiplicities, if any), several generalized zeta functions are conceivable:

$$(16) \quad \mathcal{Z}(s | t) = \sum_{\rho} (\tfrac{1}{2} + t - \rho)^{-s}, \quad \text{Re } s > 1 \quad (\text{1st kind})$$

$$(17) \quad \mathcal{Z}(\sigma | t) = \sum_{k=1}^{\infty} (\tau_k^2 + t^2)^{-\sigma}, \quad \text{Re } \sigma > \tfrac{1}{2} \quad (\text{2nd kind})$$

$$(18) \quad \mathfrak{Z}(s | \tau) = \sum_{k=1}^{\infty} (\tau_k + \tau)^{-s}, \quad \text{Re } s > 1 \quad (\text{3rd kind})$$

where the parameter t has the same meaning as in (12); those functions are 2-by-2 inequivalent, except at a single parameter location where a *confluence* occurs:

$$(19) \quad (2 \cos \tfrac{1}{2}\pi s)^{-1} \mathcal{Z}(s | 0) \equiv \mathcal{Z}(\tfrac{1}{2}s | 0) \equiv \mathfrak{Z}(s | 0) \equiv \sum_{k=1}^{\infty} \tau_k^{-s};$$

(19) can be taken as a standard (one-variable) zeta function over the Riemann zeros.

Those zeta functions over the Riemann zeros (or “superzeta” functions, for brevity) got considered quite sporadically until the turn of the century: we found but a dozen studies, all partially focused and incomplete even as a whole (Table 2). From 2000

year	$\mathcal{Z}(s t) = \sum_{\rho} (\frac{1}{2} + t - \rho)^{-s}$	$\mathcal{Z}(\sigma t) = \sum_{k=1}^{\infty} (\tau_k^2 + t^2)^{-\sigma}$	$\mathfrak{Z}(s \tau) = \sum_{k=1}^{\infty} (\tau_k + \tau)^{-s}$
1860	Riemann (unpubl.): $\sum_{\rho} \rho^{-1}$ T		
1917	Mellin $t = \pm \frac{1}{2}$ AR		Mellin $\tau = \pm \frac{1}{2}i$ A
1949		Guinand AF	
1966		Delsarte A	
1970	←—————	Chakravarty F	—————→
1971		” AR	
1985	Matsuoka	} $t = 0$ (confluent case)	
1988	Lehmer		
	$\sum_{\rho} \rho^{-n}$ $\left\{ \begin{matrix} t = \frac{1}{2} \\ s = n \end{matrix} \right.$ T		
1988		Kurokawa $t = \frac{1}{2}$ A	
1989		Matiyasevich $\left\{ \begin{matrix} t = \frac{1}{2} \\ \sigma = n \end{matrix} \right.$ T	
1992	Keiper	} $\sum_{\rho} \rho^{-n}$ T	
1994	Zhang–Williams		
1992	Deninger	} $\partial_s \mathcal{Z}(0 t)$ $\left\{ \begin{matrix} \mathbf{A} \\ \mathbf{T} \end{matrix} \right.$	
1994	Schröter–Soulé		

Table 2. The pre-2000 literature on “superzeta” functions of all 3 kinds (to our knowledge), sorted by kind (columns). (**A–T**: classes of results, cf. Sect. 1.1; n means any positive integer; the references are listed in full at the end.)

onwards we have gradually filled gaps in the description [27][29][28], ending up with a more global perspective, also set in new coherent notations, as a book [31]. The present text then basically condenses the main results of [31], where the details skipped here can be found.

§ 2.1. The superzeta function of the 1st kind $\mathcal{Z}(s|t)$

2.1.1. Basic functional relation / continuation formula

$\mathcal{Z}(s|t)$ is only defined by (16) where its series converges, i.e., in the half-plane $\{\text{Re } s > 1\}$.

Now, in terms of the partner zeta function over the *trivial zeros* of $\zeta(x)$,

$$(20) \quad \mathbf{Z}(s|t) \stackrel{\text{def}}{=} \sum_{k=1}^{\infty} (\frac{1}{2} + t + 2k)^{-s} \equiv 2^{-s} \zeta(s, \frac{5}{4} + \frac{1}{2}t),$$

and of another *Mellin transform*,

$$(21) \quad \mathcal{Z}(s|t) = \int_0^{\infty} \frac{\zeta'}{\zeta}(\frac{1}{2} + t + y) y^{-s} dy \quad (\text{Re } s < 1),$$

$\mathcal{Z}(s|t)$ admits an analytic continuation formula which reads as

$$(22) \quad \boxed{\mathcal{Z}(s|t) = -\mathbf{Z}(s|t) + (t - \frac{1}{2})^{-s} + \frac{\sin \pi s}{\pi} \mathcal{J}(s|t)} \quad (\text{Re } s < 1),$$

valid in a cut t -plane: $\frac{1}{2} + t$ must avoid all negatively oriented half-lines drawn from the Riemann zeros and the pole (whose cut $t \in (-\infty, +\frac{1}{2}]$ imposes special treatments for both remarkable values $t = 0$ and $\frac{1}{2}$).

The argument of proof (parallel to (7)–(9), and sketched by Fig. 2) shows (22) to be the counterpart of the functional relation (10) from the Hurwitz case, i.e., (22) gives the property **F** for \mathcal{Z} .

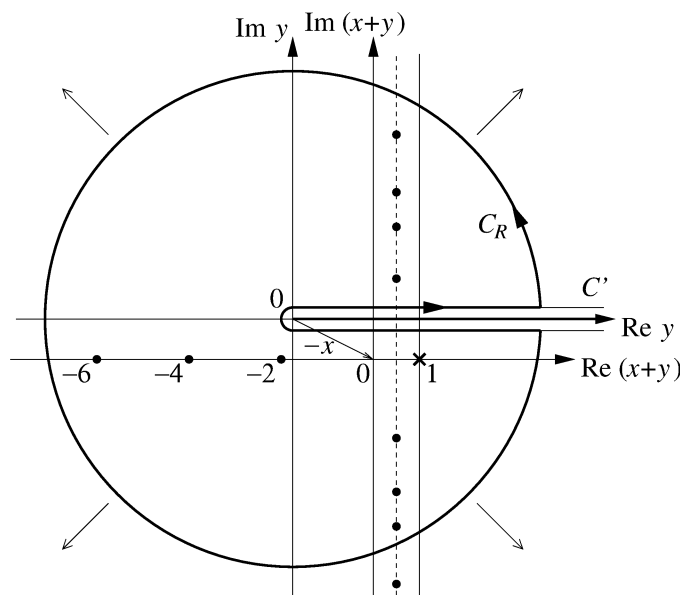

Figure 2. Integration paths applied to the Mellin transform (21) similarly to Fig. 1, leading to the analytic continuation formula (22) for $\mathcal{Z}(s|t)$. ($x \equiv \frac{1}{2} + t$; \bullet : zeros of $\zeta(x+y)$, including mock “Riemann zeros” with imaginary parts contracted to fit into the frame.)

Moreover, by the same logic as in Sect. 1.1.R, the $y \rightarrow 0$ Taylor expansion of the integrand in (21) induces the continuation of $\mathcal{J}(s|t)$ (and of the **F**-identity (22)) to the whole s -plane, and it fully specifies the poles and residues of \mathcal{J} . As a result, the product $[\sin \pi s \mathcal{J}(s|t)]$ in (22) is regular everywhere (and computable at all zeros of $\sin \pi s$ as well, in preparation to Sect. 2.1.2). Its regularity alone implies that $\mathcal{Z}(s|t)$ has the same singular structure as $-\mathbf{Z}(s|t)$: i.e., only the simple pole $s = 1$, of residue $-\frac{1}{2}$ (property **A**).

2.1.2. Special values of $\mathcal{Z}(s|t)$

Once we can compute $[\sin \pi s \mathcal{J}(s|t)]$ at all integers s , the corresponding values of $\mathcal{Z}(s|t)$ plus $\partial_s \mathcal{Z}(0|t)$ readily follow from the **F**-identity (22) (as extended to all s).

Then, in the resulting Table 3 of special values, the superzeta function \mathcal{Z} proves fully on par with the much more elementary Hurwitz zeta function of (1) !

Since $\mathcal{Z}(s|t)$ is regular for $s < 1$, its transcendental values get killed in (22) by the $\sin \pi s$ factor at all $s = 0, -1, -2, \dots$, making those $\mathcal{Z}(-n|t)$ values **rational (R)**.

The remaining, **transcendental (T)**, values $\mathcal{Z}(n|t)$ ($n = 1, 2, \dots$; more detail about $n = 1$ in [31, §7.4]) also directly stem from a generating function that goes back to a symmetric Hadamard product for $\Xi(x)$ [7, §1.10],

$$(23) \quad \Xi(x) = \prod_{\rho} (1 - x/\rho) \implies \frac{d}{dy} \log \Xi(\frac{1}{2} + t + y) \equiv \sum_{n=1}^{\infty} \mathcal{Z}(n|t) (-y)^{n-1}.$$

s	$\mathcal{Z}(s t) = \sum_{\rho} (\frac{1}{2} + t - \rho)^{-s}$		$\zeta(s, w) = \sum_{k=0}^{\infty} (k + w)^{-s}$
$-n < 0$	$\frac{2^n}{n+1} B_{n+1}(\frac{1}{4} + \frac{1}{2}t) + (t + \frac{1}{2})^n + (t - \frac{1}{2})^n$		$-\frac{1}{n+1} B_{n+1}(w)$
0	$\frac{1}{2}(t + \frac{7}{2})$	R	$\frac{1}{2} - w$
0 (<i>s-derivative</i>)	$-\frac{1}{2}(\log 2\pi)t + \frac{1}{4} \log 8\pi - \log \Xi(\frac{1}{2} + t)$	T	$-\frac{1}{2} \log 2\pi + \log \Gamma(w)$
+1 (<i>finite part</i>)	$\frac{1}{2} \log 2\pi + (\log \Xi)'(\frac{1}{2} + t)$		$-(\log \Gamma)'(w)$
+1	$(\log \Xi)'(\frac{1}{2} + t)$		∞
+ $n > 1$	$\frac{(-1)^{n-1}}{(n-1)!} (\log \Xi)^{(n)}(\frac{1}{2} + t)$		$\frac{(-1)^n}{(n-1)!} (\log \Gamma)^{(n)}(w)$

Table 3. Central column: the special values for the superzeta function of the 1st kind $\mathcal{Z}(s|t)$, Rational at all integer $s = \mp n$. Right column, for comparison: the same for the Hurwitz zeta function, rewritten from Table 1. ($B_n(\cdot)$: Bernoulli polynomials; $\Xi(\cdot)$: the completed Riemann zeta function (13).)

The special values $\mathcal{Z}(n|t)$ also display *some imprints* of the fundamental symmetry of the Riemann zeros ($\rho \longleftrightarrow (1 - \rho)$, $t \longleftrightarrow -t$) (whereas we know of *no symmetry relation* between $\mathcal{Z}(s|\pm t)$ for *non-integer s*):

- obvious: $\mathcal{Z}(n|-t) \equiv (-1)^n \mathcal{Z}(n|t)$ for $n = 1, 2, \dots \implies \mathcal{Z}(n|0) \equiv 0$ for $n > 0$ odd (vs $e^{i\pi s/2} \mathcal{Z}(s|t) - e^{-i\pi s/2} \mathcal{Z}(s|-t) \equiv 2i(\sin \pi s) \mathfrak{Z}(s|it) \neq 0$ for non-integer s , cf. (30));

- less obvious: $\mathcal{Z}(-n|-t) \equiv (-1)^n \mathcal{Z}(-n|t) + \frac{1}{n+1} B_{n+1}(\frac{1}{2} - t)$ for $n = 0, 1, 2, \dots$ (as computed from Table 3-R, with $B_{n+1}(\cdot)$: Bernoulli polynomial);

- even less obvious: $0 \equiv \sum_{k=n}^{\infty} \binom{k-1}{n-1} t^{k-n} \mathcal{Z}(k|t)$ for each odd $n = 1, 3, \dots$

(skeleton of proof: expand identity $(\frac{1}{2} - \rho)^{-n} \equiv (\frac{1}{2} + t - \rho)^{-n} [1 - t/(\frac{1}{2} + t - \rho)]^{-n}$ in powers of t , then sum over $\{\rho\}$, and finally use $\mathcal{Z}(n|0) \equiv 0$ for n odd).

The next two Tables exemplify Table 3 for $\mathcal{Z}_0(s) \stackrel{\text{def}}{=} \mathcal{Z}(s|0)$, resp. $\mathcal{Z}_*(s) \stackrel{\text{def}}{=} \mathcal{Z}(s|\frac{1}{2})$.

s	$\mathcal{Z}_0(s) \equiv \sum_{\rho} (\rho - \frac{1}{2})^{-s}$	$[t = 0]$
$-n \leq 0$	$\begin{cases} \text{even} & 2^{-n+1}(1 - \frac{1}{8}E_n) \\ \text{odd} & -\frac{1}{2}(1-2^{-n})\frac{B_{n+1}}{n+1} \end{cases}$	
0	$7/4$	R
0 <i>(s-derivative)</i>	$\mathcal{Z}'_0(0) = \log [2^{11/4}\pi^{1/2}\Gamma(\frac{1}{4})^{-1} \zeta(\frac{1}{2}) ^{-1}]$	T
$+1$ <i>(finite part)</i>	$\text{FP}_{s=1} \mathcal{Z}_0(s) = \frac{1}{2} \log 2\pi$	
$+n \geq 1$	$\begin{cases} \text{odd} & 0 \\ \text{even} & 2^{n+1} - \frac{1}{2} [(2^n - 1)\zeta(n) + 2^n\beta(n)] - \frac{(\log \zeta)^{(n)}(\frac{1}{2})}{(n-1)!} \end{cases}$	$[\zeta(n) \equiv \frac{(2\pi)^n B_n }{2n!}]$

Table 4. (E_n : Euler numbers; B_n : Bernoulli numbers; $\beta(x) \stackrel{\text{def}}{=} \sum_{k=0}^{\infty} (-1)^k (2k+1)^{-x}$: Dirichlet β -function.)

s	$\mathcal{Z}_*(s) \equiv \sum_{\rho} \rho^{-s}$	$[t = \frac{1}{2}]$
$-n < 0$	$1 - (2^n - 1)\frac{B_{n+1}}{n+1}$	
0	2	R
0 <i>(s-derivative)</i>	$\mathcal{Z}'_*(0) = \frac{1}{2} \log 2$	T
$+1$ <i>(finite part)</i>	$\text{FP}_{s=1} \mathcal{Z}_*(s) = 1 - \frac{1}{2} \log 2 + \frac{1}{2}\gamma$	
$+1$	$1 - \frac{1}{2} \log 4\pi + \frac{1}{2}\gamma$	
$+n > 1$	$1 - (1-2^{-n})\zeta(n) + \frac{g_n^c}{(n-1)!} \equiv 1 - (-1)^n 2^{-n}\zeta(n) - \frac{(\log \zeta)^{(n)}(0)}{(n-1)!}$	

Table 5. (γ : Euler's constant; g_n^c : cumulants of the Stieltjes constants [14, § 5][2][27, § 3.3][4], of generating function $\log [y\zeta(1+y)] \equiv -\sum_{n=1}^{\infty} \frac{(-1)^n}{n!} g_n^c y^n$; $\zeta(n) \equiv \frac{(2\pi)^n |B_n|}{2n!}$ for n even.)

§ 2.2. The superzeta function of the 2nd kind $\mathcal{Z}(\sigma|t)$

Defined by (17) for $\text{Re } \sigma > \frac{1}{2}$, $\mathcal{Z}(\sigma|t)$ appears (for $t \neq 0$) functionally independent from the function of the 1st kind $\mathcal{Z}(s|t)$; contrary to the latter, it manifestly embodies the full symmetry of the Riemann zeros, through the identity $\mathcal{Z}(\sigma|t) \equiv \mathcal{Z}(\sigma|-t)$.

On the other hand, $\mathcal{Z}(\sigma|t)$ for $t \neq 0$ displays no tractable functional relation **F**.

Still, by expansion in powers of t around the known confluent case (19) [27, § 6.1][31, § 8.3], $\mathcal{Z}(\sigma | t)$ is proved meromorphic in σ , now with *double* poles $\sigma = \frac{1}{2}, -\frac{1}{2}, -\frac{3}{2}, \dots$, and all principal parts plus rational values $\mathcal{Z}(-m | t)$ ($m \in \mathbb{N}$) explicitly computable (**A+R**). E.g., the leading pole $\sigma = \frac{1}{2}$ has the principal part (t -independent)

$$(24) \quad \mathcal{Z}\left(\frac{1}{2} + \varepsilon | t\right) = \frac{1}{8\pi} \varepsilon^{-2} - \frac{\log 2\pi}{4\pi} \varepsilon^{-1} + [\text{regular term}], \quad \varepsilon \rightarrow 0. \quad (\mathbf{A})$$

2.2.1. Special values of $\mathcal{Z}(\sigma | t)$ (continued)

The remaining, *transcendental* (**T**), values $\mathcal{Z}(m | t)$ ($m = 1, 2, \dots$) stem from a variant of (23) [7, § 1.10],

$$(25) \quad \Xi(x) = \prod_{\text{Im}\rho > 0} \left[1 - \frac{x(1-x)}{\rho(1-\rho)} \right] \Rightarrow \frac{d}{dw} \log \Xi\left(\frac{1}{2} + (t^2+w)^{1/2}\right) \equiv \sum_{m=1}^{\infty} \mathcal{Z}(m | t) (-w)^{m-1};$$

only the derivative $\partial_\sigma \mathcal{Z}(\sigma | t)|_{\sigma=0}$ is harder to obtain (see [27, § 4][31, § 8.4]), and that completes Table 6.

σ	$\mathcal{Z}(\sigma t) = \sum_{k=1}^{\infty} (\tau_k^2 + t^2)^{-\sigma}$	
$-m < 0$	$(t^2 - \frac{1}{4})^m - 2^{-2m-3} \sum_{j=0}^m \binom{m}{j} (-1)^j E_{2j} (2t)^{2(m-j)}$	
0	7/8	R
$\frac{0}{(\sigma\text{-derivative})}$	$\partial_\sigma \mathcal{Z}(0 t) = \frac{1}{4} \log 8\pi - \log \Xi\left(\frac{1}{2} + t\right)$	T
$+m \geq 1$	$\frac{(-1)^{m-1}}{(m-1)!} \frac{d^m}{d(t^2)^m} (\log \Xi)\left(\frac{1}{2} + t\right)$	

Table 6. The special values for the superzeta function of the 2nd kind $\mathcal{Z}(\sigma | t)$, Rational at all integer $\sigma = \mp m$. (E_n : Euler numbers; $\Xi(\cdot)$: the completed Riemann zeta function (13).)

The change of variables $t + y = (t^2 + w)^{1/2}$ in the generating function (23) (at fixed t , say $t \geq 0$) also has to yield (25), hence the $\mathcal{Z}(m | t)$ ($m = 1, 2, \dots$) must relate to the $\mathcal{Z}(n | t)$ ($1 \leq n \leq m$). To get a fully explicit connection, our shortcut (new) is to use the residue calculus twice, inside small positive contours encircling $y = 0$, resp. $w = 0$:

$$(26) \quad \frac{(-1)^{n-1}}{2\pi i} \oint \frac{d \log \Xi\left(\frac{1}{2} + t + y\right)}{y^n} = \begin{cases} \mathcal{Z}(n | t) & \text{for } n = 1, 2, \dots, \\ 0 & \text{for } n \in \mathbb{Z} \text{ otherwise;} \end{cases}$$

$$\mathcal{Z}(m | t) = \frac{(-1)^{m-1}}{2\pi i} \oint \frac{d \log \Xi\left(\frac{1}{2} + (t^2 + w)^{1/2}\right)}{w^m} = \frac{(-1)^{m-1}}{2\pi i} \oint \frac{d \log \Xi\left(\frac{1}{2} + t + y\right)}{(2ty + y^2)^m}$$

$$= \frac{(-1)^{m-1}}{2\pi i} \oint \sum_{\tilde{n}=-m}^{\infty} (-1)^{m+\tilde{n}} \binom{2m+\tilde{n}-1}{m-1} (2t)^{-2m-\tilde{n}} y^{\tilde{n}} d \log \Xi\left(\frac{1}{2} + t + y\right) \quad (t \neq 0)$$

$$(27) \quad \equiv \sum_{n=1}^m \binom{2m-n-1}{m-1} (2t)^{-2m+n} \mathcal{Z}(n|t) \quad \text{for } m = 1, 2, \dots, \text{ and } t \neq 0$$

by (26) (vs (28) below for $t = 0$); e.g., the first of the identities (27) is $\mathcal{Z}(1|t) \equiv \frac{\mathcal{Z}(1|t)}{2t}$.

All in all and notwithstanding its lack of a tractable functional relation **F**, the superzeta function of the 2nd kind matches its partner of the 1st kind (or the Hurwitz zeta function) for its stock of explicit fixed- σ properties.

Next, we exemplify those formulae at the special parameter values $t = 0$ and $\frac{1}{2}$.

For $\mathcal{Z}_0(\sigma) = \mathcal{Z}(\sigma|t = 0)$ (the confluent case), Table 4 can be reused since (19) entails

$$(28) \quad \mathcal{Z}_0(m) \equiv \frac{1}{2}(-1)^m \mathcal{Z}_0(2m) \quad (m \in \mathbb{Z}), \quad \frac{d}{d\sigma} \mathcal{Z}_0(0) = \frac{d}{ds} \mathcal{Z}_0(0).$$

Whereas for $\mathcal{Z}_*(\sigma) = \mathcal{Z}(\sigma|t = \frac{1}{2})$, Table 6 plus (27) specialize to:

σ	$\mathcal{Z}_*(\sigma) = \sum_{k=1}^{\infty} (\tau_k^2 + \frac{1}{4})^{-\sigma} \quad [t = \frac{1}{2}]$	
$-m < 0$	$-2^{-2m-3} \sum_{j=0}^m \binom{m}{j} (-1)^j E_{2j}$	
0	$7/8$	R
0 (σ -derivative)	$\mathcal{Z}'_*(0) = \frac{1}{4} \log 8\pi$	T
$+m \geq 1$	$\sum_{n=1}^m \binom{2m-n-1}{m-1} \mathcal{Z}_*(n)$	

Table 7. As Table 6, but at $t = \frac{1}{2}$. (E_n : Euler numbers; values $\mathcal{Z}_*(n)$: see Table 5.)

§ 2.3. The superzeta function of the 3rd kind $\mathfrak{Z}(s|\tau)$

Defined by (18) for $\text{Re } s > 1$, $\mathfrak{Z}(s|\tau)$ is less regular than the other two kinds [12, § 3][27, § 6.2], nevertheless it reduces to functions of the 1st kind: indeed, the straightforward identity

$$(29) \quad \mathcal{Z}(s|t) \equiv e^{i\pi s/2} \mathfrak{Z}(s|it) + e^{-i\pi s/2} \mathfrak{Z}(s|-it)$$

can be inverted, yielding [23, § 8][31, Chap. 9]

$$(30) \quad \mathfrak{Z}(s|\tau) \equiv \frac{1}{2i \sin \pi s} [e^{i\pi s/2} \mathcal{Z}(s|-i\tau) - e^{-i\pi s/2} \mathcal{Z}(s|+i\tau)].$$

The singular structure of \mathfrak{Z} is thus computable just as before; on the other hand, only one special value remains explicit: the finite part of $\mathfrak{Z}(s|\tau)$ at $s = 0$, which reads $\frac{7}{8} + \frac{\log 2\pi}{2\pi} \tau$.

§ 2.4. Extensions

Those currently include, but should not be limited to, (zeta functions over the zeros of:

- Dedekind zeta functions (for algebraic number fields) [16][12][11][13][28]
- Dirichlet L-functions (for real primitive Dirichlet characters) [28]
- Selberg zeta functions (for cocompact subgroups of $SL(2, \mathbb{R})$) - with more work ([31, App. B] and refs. therein).

In every such extension, $\mathcal{Z}_*(1) = \sum_{\rho} 1/\rho$ is closely related to the associated *generalized Euler constant* (= *Euler-Kronecker invariant*), a major invariant of the zeta function [11][13].

§ 3. Complex-asymptotic view of Riemann Hypothesis

§ 3.1. The Keiper–Li coefficients λ_n

The sequence of real numbers

$$(31) \quad \lambda_n = \sum_{\rho} [1 - (1 - 1/\rho)^n] \quad (n = 1, 2, \dots),$$

(in Li's notation [19], amounting to n times Keiper's λ_n [15]), of generating function

$$(32) \quad \log \Xi \left(x = \frac{1}{1-z} \right) \equiv \sum_{n=1}^{\infty} \frac{\lambda_n}{n} z^n,$$

has served to recast the Riemann Hypothesis (RH) (cf. (15)), as

$$\text{RH} \iff \lambda_n > 0 \text{ for all } n \quad (\text{Li's criterion}) [19][2].$$

Here we review the (large- n) *asymptotics* of the λ_n instead [15][20][30][17], and our resulting *asymptotic criterion for RH* that involves just the *tail* of the sequence $\{\lambda_n\}$ [30][31, Chap. 11].

§ 3.2. Exponential-asymptotic large- n analysis of λ_n

The Hadamard product formula in (25) implies

$$(33) \quad \log \Xi \left(\frac{1}{1-z} \right) = \sum_{k=1}^{\infty} \log \left[1 + \frac{z}{(\tau_k^2 + \frac{1}{4})(1-z)^2} \right] = - \sum_{m=1}^{\infty} \frac{\mathcal{Z}_*(m)}{m} \frac{(-z)^m}{(1-z)^{2m}}$$

(the $\mathcal{Z}_*(m)$ are in Table 7); then, expanding $(1 - z)^{-2m}$ by the generalized binomial formula, reordering in powers of z and substituting into (32), we get [30][31, § 8.6.2]

$$(34) \quad \lambda_n = -n \sum_{m=1}^n \frac{(-1)^m}{m} \binom{m+n-1}{2m-1} \mathcal{Z}_*(m), \quad n = 1, 2, \dots$$

This yields a representation by an integral over the superzeta function $\mathcal{Z}_*(\sigma) \equiv \mathcal{Z}(\sigma | \frac{1}{2})$ (of the 2nd kind),

$$(35) \quad \lambda_n = \frac{(-1)^n n i}{\pi} \oint_C \frac{\Gamma(\sigma+n)\Gamma(\sigma-n)}{\Gamma(2\sigma+1)} \mathcal{Z}_*(\sigma) d\sigma,$$

as proved by reduction to (34) using the residue calculus, see Fig. 3. Our point is now that for $n \rightarrow +\infty$ (and after using the Stirling formula in the numerator), the integral form (35) is asymptotically computable thanks to the *method of steepest descents* [8].

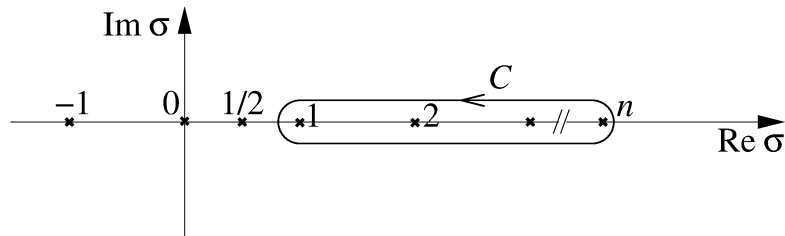

Figure 3. Contour of integration for (35). (x : poles of the integrand.)

With the integrand in (35) behaving like $n^{2\sigma-1}$ for $n \rightarrow +\infty$, that means to push the integration path along decreasing $\text{Re } \sigma$, up to *saddle-points* of the integrand where dominant contributions to the integral will localize. Here, saddle-points σ_* of two species compete in the half-plane $\{\text{Re } \sigma > \frac{1}{2}\}$ for dominance (= largest $\text{Re } \sigma_*$), see Fig. 4 [30]:

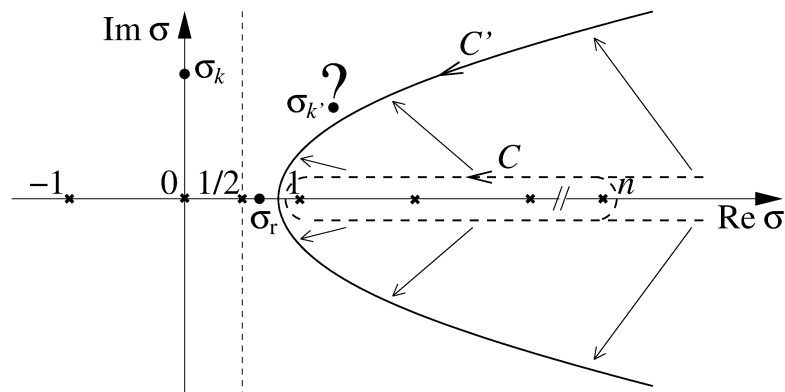

Figure 4. Integration-path deformation for a large- n evaluation of the integral (35). • : typical saddle-points (none on scale); $\sigma_k(n)$ comes from a Riemann zero $\frac{1}{2} + i\tau_k$ on the critical line (and is irrelevant, beyond reach), $\sigma_{k'}(n)$ comes from a *putative* (“?”) zero $\frac{1}{2} + i\tau_{k'}$ off the critical line (and then, gives a dominant contribution), finally $\sigma_r(n)$ is the real saddle-point tending to the pole $\sigma = 1/2$ from above (and gives the dominant contribution if and only if RH holds).

- using $\mathcal{Z}_*(\sigma) = \sum_k (\tau_k^2 + \frac{1}{4})^{-\sigma}$ to integrate (35) term by term: then the k -th integrand has a saddle-point $\sigma_k(n) \sim \frac{1}{2} n i / \tau_k$, which is relevant iff $\arg \tau_k > 0$, as this is the necessary and sufficient condition for that saddle-point to ultimately reside in the half-plane $\{\operatorname{Re} \sigma > \frac{1}{2}\}$ (that is, for $n \gtrsim |\operatorname{Im} 1/\tau_k|^{-1}$);
- the pair of poles $\sigma = +\frac{1}{2}$ of \mathcal{Z}_* as in (24) and $\sigma = 1$ of $\Gamma(\sigma - n)$ together force a *real* local minimum in the modulus of the integrand, unconditionally: $\sigma_r(n) \sim \frac{1}{2} + \frac{1}{\log n}$, this is another saddle-point, and the dominant one iff all $\arg \tau_k \equiv 0$ (i.e., RH true).

Thus, the competition between both types of saddle-point contributions to (35) results in this *asymptotic criterion for RH* [30]: as $n \rightarrow +\infty$,

- **if RH is false**, λ_n has an *exponentially growing* oscillatory behavior:

$$(36) \quad \lambda_n \sim - \sum_{\{\arg \tau_k > 0\}} \left(\frac{\tau_k + i/2}{\tau_k - i/2} \right)^n + \text{c. c.} \quad (\text{mod } o(e^{\varepsilon n}) \forall \varepsilon > 0)$$

- **if RH is true**, λ_n has a *tempered* growth to $+\infty$:

$$(37) \quad \lambda_n \sim \frac{1}{2} n (\log n - 1 + \gamma - \log 2\pi) \quad (\text{mod } o(n)).$$

However, if a numerical crossover from the latter (RH) to the former (non-RH) behavior is sought as a signal of a violation of RH, that has to await a huge value $n \approx 10^{18}$ at least, corresponding to the present height up to which $\operatorname{Re} \rho = \frac{1}{2}$ has been verified [17].

§ 3.3. Extensions

For zeros of a more general zeta function as in Sect. 2.4, and such that

$$(38) \quad \mathcal{Z}_*(\frac{1}{2} + \varepsilon) = R_{-2} \varepsilon^{-2} + R_{-1} \varepsilon^{-1} + O(1)_{\varepsilon \rightarrow 0} \quad (\text{with } R_{-2} > 0),$$

(generalizing (24) from the case of the Riemann zeros), then the *Generalized Riemann Hypothesis* is equivalent to

$$(39) \quad \lambda_n \sim (-1)^n 2n \operatorname{Res}_{\sigma=1/2} \left[\frac{\Gamma(\sigma + n)\Gamma(\sigma - n)}{\Gamma(2\sigma + 1)} \mathcal{Z}_*(\sigma) \right]$$

$$(40) \quad \sim 2\pi n [2R_{-2}(\log n - 1 + \gamma) + R_{-1}] \quad (\text{mod } o(n))$$

for its corresponding Keiper–Li sequence $\{\lambda_n\}$ as $n \rightarrow \infty$ [17]; the constants R_{-2} , R_{-1} are also those governing the asymptotic *counting function* of the zeros' ordinates, as

$$(41) \quad N(T) \sim 2T [2R_{-2}(\log T - 1) + R_{-1}] \quad (T \rightarrow +\infty).$$

§ 3.4. (New) Shifted asymptotic and Li criteria for RH

(returning to the Riemann-zeta case alone, for the sake of definiteness).

The Keiper–Li (KL) generating series (32) combines two features: a high sensitivity to the Riemann Hypothesis through its radius of convergence ($|z| = 1$ if and only if RH holds vs *strictly less* otherwise), obtained by the use of a conformal mapping $z \mapsto x$ that sends the disk $\{|z| < 1\}$ to the half-plane $\{\operatorname{Re} x > \frac{1}{2}\}$; and an expansion basepoint (the image of $z = 0$) set to $x = 1$ (hence the parameter $t \equiv x - \frac{1}{2}$ is $\frac{1}{2}$ in the superzeta function entering § 3.2: $\mathcal{Z}_*(\sigma) \stackrel{\text{def}}{=} \mathcal{Z}(\sigma | \frac{1}{2})$). The two features always appeared coupled, as the conformal mapping was invariably prescribed to be $x = 1/(1 - z)$, as in (32).

Yet, we claim that imposing only $x = 1$ as basepoint is an *unnecessary limitation*. To wit, we present an alternative KL-like framework based at the other remarkable point $x = \frac{1}{2}$ (the center of symmetry), i.e., $t = 0$. In the last minute, we saw that the idea of a general basepoint had been developed elsewhere, only recently and in a different manner that just excludes our preferred symmetrical point $x = \frac{1}{2}$ [26].

For expanding $\Xi(x)$ about $x = \frac{1}{2}$, due to (12) the good variable is $w = t^2$, in which the above half-plane $\{\operatorname{Re} x > \frac{1}{2}\}$ maps to the cut w -plane $\mathbb{C} \setminus \mathbb{R}^-$; this cut can then be truncated to any half-line $(-\infty, -w']$ with $0 < w' < \inf_{\rho} \{|\operatorname{Im} \rho|^2\}$ (that only deletes a zero-free segment), and here we choose $w' = \frac{1}{4}$ just to make the formulae simpler and closest to the KL case. There now remains to map to the cut w -plane $\mathbb{C} \setminus (-\infty, -\frac{1}{4}]$ from a unit disk $\{|y| < 1\}$, which is achieved by $w = y/(1 - y)^2$. Under the resulting $y \mapsto x$ correspondence, we will need the preimages of a Riemann zero $\rho = \frac{1}{2} + i\tau_k$, as

$$(42) \quad y_{k,\pm} = 1 - \frac{1}{2\tau_k^2} \pm \frac{i}{\tau_k} \left(1 - \frac{1}{4\tau_k^2}\right)^{1/2} \equiv e^{\pm i\theta_k} \quad \text{with } \theta_k \stackrel{\text{def}}{=} 2 \arcsin \frac{1}{2\tau_k}.$$

Now we start from the generating function (25) at $t = 0$ and integrate in w , to get $\log \Xi_0(\frac{1}{2} + w^{1/2}) \equiv - \sum_{m=1}^{\infty} \frac{\mathcal{Z}_0(m)}{m} (-w)^m$ where $\Xi_0(x) \stackrel{\text{def}}{=} \Xi(x)/\Xi(\frac{1}{2})$, amounting to

$$(43) \quad \sum_{n=1}^{\infty} \frac{\lambda_n^0}{n} y^n \stackrel{\text{def}}{=} \log \Xi_0\left(\frac{1}{2} + \frac{y^{1/2}}{1 - y}\right) \equiv - \sum_{m=1}^{\infty} \frac{\mathcal{Z}_0(m)}{m} \frac{(-y)^m}{(1 - y)^{2m}};$$

thus, we created a KL-like sequence of “central” coefficients λ_n^0 . Comparing to (32)–(33), we see that the relationships (34) persist with the λ_n substituted by the λ_n^0 and the superzeta function \mathcal{Z}_* by \mathcal{Z}_0 . (Equivalently, by (28) and Table 3 at $t = 0$,

$$(44) \quad \lambda_n^0 = -\frac{n}{2} \sum_{m=1}^n \binom{m+n-1}{2m-1} \frac{1}{m} \mathcal{Z}_0(2m) = n \sum_{m=1}^n \binom{m+n-1}{2m-1} \frac{1}{(2m)!} (\log \Xi)^{(2m)}\left(\frac{1}{2}\right),$$

and the last line in Table 4 displays $\mathcal{Z}_0(2m)$ in most reduced form.) E.g.,

$$(45) \quad \lambda_1^0 = \mathcal{Z}_0(1) = \frac{1}{2} (\log \Xi)''\left(\frac{1}{2}\right) \approx 0.0231050,$$

$$(46) \quad \lambda_2^0 = 4 \mathcal{Z}_0(1) - \mathcal{Z}_0(2) = 2 (\log \Xi)''\left(\frac{1}{2}\right) + \frac{1}{12} (\log \Xi)^{(4)}\left(\frac{1}{2}\right) \approx 0.0923828, \dots$$

Being based upon (34), our asymptotic analysis of $\{\lambda_n\}$ sketched in § 3.2 [30][31, Chap. 11] then carries over likewise to $\{\lambda_n^0\}$, and it now yields this *shifted asymptotic criterion* for RH:

$$(47) \quad \text{- if RH is false, } \lambda_n^0 \sim - \sum_{\{\arg \tau_k > 0\}} y_{k,-}^{-n} + \text{c. c.},$$

an exponentially growing oscillatory behavior (like (36)) since $|y_{k,-}^{-1}| > 1$ if $\arg \tau_k > 0$;

$$(48) \quad \text{- if RH is true, } \lambda_n^0 \sim \frac{1}{2}n (\log n - 1 + \gamma - \log 2\pi),$$

the latter being unchanged from (37), as according to § 3.3 it arises from the principal part (24) of $\mathcal{Z}(\sigma | t)$ at $\sigma = \frac{1}{2}$, and (24) is t -independent.

Finally, *Li's criterion* [19] shifts as well: by the Hadamard product formula in (25),

$$(49) \quad \log \Xi_0 \left(\frac{1}{2} + \frac{y^{1/2}}{1-y} \right) = \sum_k \log \left[1 + \frac{y}{\tau_k^2 (1-y)^2} \right]$$

$$(50) \quad = \sum_k (-\log(1-y)^2 + \log [(1-y/y_{k,-})(1-y/y_{k,+})])$$

$$(51) \quad = \sum_{n=1}^{\infty} \left[\sum_k (2 - y_{k,-}^{-n} - y_{k,+}^{-n}) \right] \frac{y^n}{n}$$

$$(52) \quad \implies \lambda_n^0 \equiv \sum_k (2 - y_{k,-}^{-n} - y_{k,+}^{-n}) \quad \text{by identification with (43).}$$

Now if RH is true, then for all k , τ_k is purely real and so is θ_k in (42), in which case $y_{k,\pm} = e^{\pm i\theta_k}$ makes (52) manifestly positive for all n . Whereas if RH is false, then as $n \rightarrow +\infty$, the growing oscillatory behavior (47) will force some λ_n^0 into the negative range. So, the Li criterion transfers to this “central” sequence:

$$(53) \quad \text{RH} \quad \iff \quad \lambda_n^0 > 0 \quad \text{for all } n.$$

Remark. Other expressions for the λ_n^0 , derivable from (43) by using the residue calculus both ways (similarly to the proof of (27)), are

$$(54) \quad \lambda_n^0 \equiv \frac{n}{2\pi i} \oint \log \Xi_0 \left(\frac{1}{2} + \frac{y^{1/2}}{1-y} \right) \frac{dy}{y^{n+1}} \quad (n = 1, 2, \dots)$$

$$\equiv \frac{n}{4\pi i} \oint \log \Xi_0 \left(\frac{1}{2} + t \right) (t^2 + \frac{1}{4})^{-1/2} \left[\frac{t^2}{y(t)} \right]^n \frac{dt}{t^{2n+1}}$$

$$\text{(upon the change of variable } t \equiv \frac{y^{1/2}}{1-y} \text{ implying } dy(t) = (t^2 + \frac{1}{4})^{-1/2} y \frac{dt}{t} \text{)}$$

$$(55) \quad \equiv \frac{1}{4 [2(n-1)]!} \left(\frac{d}{dt} \right)^{2n} \left[(t^2 + \frac{1}{4})^{-1/2} (1-y(t))^{-2n} \log \Xi_0 \left(\frac{1}{2} + t \right) \right]_{t=0}.$$

Acknowledgements

We are most grateful to the conference organizers and to the Research Institute for Mathematical Sciences of Kyoto University for their kind invitation and generous support.

References

- [1] Aoki, T., Kanemitsu, S., Nakahara, M. and Ohno, Y. (eds.), *Zeta Functions, Topology and Quantum Physics* (Proceedings, Kinki University, Osaka, March 2003), *Developments in Mathematics*, **14**, Springer-Verlag (2005).
- [2] Bombieri, E. and Lagarias, J. C., Complements to Li's criterion for the Riemann Hypothesis, *J. Number Theory*, **77** (1999), 274–287.
- [3] Chakravarty, I. C., The secondary zeta-functions, *J. Math. Anal. Appl.*, **30** (1970), 280–294; Certain properties of a pair of secondary zeta-functions, *ibid.*, **35** (1971), 484–495; On the functional equation of the secondary zeta-functions, *Aequat. Math.*, **14** (1976), 49–57.
- [4] Coffey, M. W., Toward verification of the Riemann Hypothesis: application of the Li criterion, *Math. Phys. Anal. Geom.*, **8** (2005), 211–255, and: New results concerning power series expansions of the Riemann xi function and the Li/Keiper constants, *Proc. R. Soc. Lond.*, **A 464** (2008), 711–731.
- [5] Delsarte, J., Formules de Poisson avec reste, *J. Anal. Math.* (Jerusalem), **17** (1966), 419–431.
- [6] Deninger, C., Local L -factors of motives and regularized determinants, *Invent. Math.*, **107** (1992), 135–150 (Thm 3.3 and Sect. 4).
- [7] Edwards, H. M., *Riemann's Zeta Function*, Academic Press (1974).
- [8] Erdélyi, A., *Asymptotic Expansions*, Dover (1956), § 2.5.
- [9] Erdélyi, A. (ed.), *Higher Transcendental Functions* (Bateman Manuscript Project), Vol. I chap. I and Vol. III chap. XVII, McGraw–Hill, New York (1953 and 1955).
- [10] Guinand, A. P., A summation formula in the theory of prime numbers, *Proc. London Math. Soc. Series 2*, **50** (1949), 107–119 (Sect. 4(A)).
- [11] Hashimoto, Y., Iijima, Y., Kurokawa, N. and Wakayama, M., Euler's constants for the Selberg and the Dedekind zeta functions, *Bull. Belg. Math. Soc. Simon Stevin*, **11** (2004), 493–516.
- [12] Hirano, M., Kurokawa, N. and Wakayama, M., Half zeta functions, *J. Ramanujan Math. Soc.*, **18** (2003), 195–209.
- [13] Ihara, Y., On the Euler–Kronecker constants of global fields and primes with small norms, *Algebraic Geometry and Number Theory. In Honor of Vladimir Drinfeld's 50th Birthday*, Ginzburg, V. ed., *Progress in Mathematics*, **253**, Birkhäuser (2006), 407–451.
- [14] Israilov, M. I., On the Laurent expansion of the Riemann zeta-function, *Proc. Steklov Inst. Math.*, **158** [Russian: (1981), 98–104] [English: (1983), 105–112].
- [15] Keiper, J. B., Power series expansions of Riemann's ξ function, *Math. Comput.*, **58** (1992), 765–773.
- [16] Kurokawa, N., Parabolic components of zeta functions, *Proc. Japan Acad.*, **64**, Ser. A (1988), 21–24, and: Special values of Selberg zeta functions, *Algebraic K-Theory and Algebraic Number Theory* (Proceedings, Honolulu 1987), Stein, M. R. and Keith Dennis, R. eds., *Contemp. Math.*, **83**, Amer. Math. Soc. (1989), 133–149 (§ 3).

- [17] Lagarias, J. C., Li coefficients for automorphic L -functions, *Ann. Inst. Fourier* (Grenoble), **57** (2007), 1689–1740.
- [18] Lehmer, D. H., The sum of like powers of the zeros of the Riemann zeta function, *Math. Comput.*, **50** (1988), 265–273 (and refs. therein).
- [19] Li, X.-J., The positivity of a sequence of numbers and the Riemann Hypothesis, *J. Number Theory*, **65** (1997), 325–333.
- [20] Maślanka, K., Li’s criterion for the Riemann hypothesis — numerical approach, *Opuscula Math.*, **24** (2004), 103–114.
- [21] Matiyasevich, Yu. V., A relationship between certain sums over trivial and nontrivial zeros of the Riemann zeta-function, *Mat. Zametki*, **45** (1989), 65–70 [*Math. Notes* (Acad. Sci. USSR), **45** (1989), 131–135.]
- [22] Matsuoka, Y., A note on the relation between generalized Euler constants and the zeros of the Riemann zeta function, *J. Fac. Educ. Shinshu Univ.*, **53** (1985), 81–82, and: A sequence associated with the zeros of the Riemann zeta function, *Tsukuba J. Math.*, **10** (1986), 249–254.
- [23] Mellin, Hj., Über die Nullstellen der Zetafunktion, *Ann. Acad. Sci. Fenn.*, **A10** (1917), No. 11 [English translation: App. D in [31]].
- [24] Riemann, B., Über die Anzahl der Primzahlen unter einer gegebenen Grösse, *Monatsb. Preuss. Akad. Wiss.*, (Nov. 1859), 671–680 [English translation, by Baker, R., Christenson, C. and Orde, H.: *Bernhard Riemann: Collected Papers*, paper VII, Kendrick Press (2004), 135–143].
- [25] Schröter, M. and Soulé, C., On a result of Deninger concerning Riemann’s zeta function, *Motives*, Part 1, *Proc. Symp. Pure Math.*, **55** (1994), 745–747.
- [26] Sekatskii, S. K., Generalized Bombieri–Lagarias’ theorem and generalized Li’s criterion with its arithmetic interpretation, *Ukr. Mat. Zh.*, **66** (2014), 371–383 [Western edition: *Ukr. Math. J.*, **66** (2014), 415–431], and: Asymptotic of the generalized Li’s sums which non-negativity is equivalent to the Riemann Hypothesis, arXiv:1403.4484 .
- [27] Voros, A., Zeta functions for the Riemann zeros, *Ann. Inst. Fourier* (Grenoble), **53** (2003), 665–699 [erratum: **54** (2004), 1139].
- [28] Voros, A., Zeta functions over zeros of general zeta and L -functions, [1], p. 171–196 [erratum: in Tables 2–7 some brackets turned blank in the final printing, making a few formulae ambiguous].
- [29] Voros, A., More zeta functions for the Riemann zeros, *Frontiers in Number Theory, Physics and Geometry*, vol. 1: *On Random Matrices, Zeta Functions, and Dynamical Systems* (Proceedings, Les Houches, March 2003), Cartier, P., Julia, B., Moussa, P. and Vanhove, P. eds., Springer-Verlag (2006, **corrected 2nd printing**), 349–363.
- [30] Voros, A., Sharpenings of Li’s criterion for the Riemann Hypothesis, *Math. Phys. Anal. Geom.*, **9** (2006), 53–63 [erratum: all asymptotic terms like (18) for λ_n under [RH false] require a sign-flip, with no impact upon the rest].
- [31] Voros, A., *Zeta functions over zeros of zeta functions*, *Lecture Notes of the Unione Matematica Italiana*, **8**, Springer-Verlag (2010) [erratum: in Chap. 11, all asymptotic terms for λ_n under [RH false] require a sign-flip, with no impact upon the rest].
- [32] Zhang, N.-Y. and Williams, K. S., Some results on the generalized Stieltjes constants, *Analysis*, **14** (1994), 147–162.