

Superconductivity Centennial Conference

Current limiting and recovery characteristics under load of transformer type SFCL with rewound structure using BSCCO wire in model power system

Sho Noda^a, Sayaka Oda^a, Masato Mori^b, Keisuke Hattori^b, Jumpei Baba^b,
Yasuyuki Shirai^{a,*}

^aKyoto University, Graduate School of Energy Science, Kyoto, 606-5801, Japan

^bThe University of Tokyo, Bunkyo-ku, Tokyo, Japan

Abstract

We have proposed new design of a transformer type SFCL with primary and secondary superconducting coils which has rewound structure. For not so large fault current, the proposed SFCL limits the current by the inductive component by the normal transition of the flux shielding coil (secondary), and for larger fault current, it can give the resistive component additively by the normal transition of the primary coil. The recovery characteristics under load condition and repetitive limiting operation were experimentally investigated in a laboratory scale power system. The SFCL limited twice repetitive faults current and recovered quickly under load condition.

© 2012 Published by Elsevier B.V. Selection and/or peer-review under responsibility of the Guest Editors.
Open access under [CC BY-NC-ND license](https://creativecommons.org/licenses/by-nc-nd/4.0/).

Keywords: liquid hydrogen, MgB₂, overcurrent, electrical resistivity, heat transfer ;

1. Introduction

The electric power system has become more complicated and a fault current is getting larger due to the increasing electric power demand. Consequently the load to a circuit breaker is increasing. So if the power systems is expanded and complicated in this pace, the reliability and stability of the power system becomes worse. Under this condition, SFCLs are expected to be introduced in order to limit the fault

* Sho Noda.

E-mail address: noda@pe.energy.kyoto-u.ac.jp

current and to improve reliability and stability of the power system. Therefore many studies on SFCL have been carried out [1], [2],[3].

SFCLs can be classified into R-types (Resistive) and L-types (Inductive) by current limiting impedance. The L-type SFCLs limit the fault current by inductance. They have advantages of being able to limit the AC component of the fault current and to suppress the voltage drop at the faults. On the other hand, the R-type SFCLs limit the fault current by resistance. They have advantages of being able to consume the energy at the faults limit the DC component also. These features may contribute to the power system stability and reliability [4].

For the application of high temperature superconducting (HTS) wires to the superconducting/normal transition type SFCL, the larger resistance of the wire at the normal state is preferable. And the inductive current limiting, for example, the transformer type FCL, has more advantage in recovery characteristics than the resistive one. However, in inductive FCL of transformer type, when the required inductance is given, the length of the HTS wire, that is, the resistance of the wire at the normal state [5], [6] is also fixed.

To solve this problem, it has been proposed a special structure of transformer type FCL having rewound coils [3],[7]. This SFCL with rewound structure was designed and made by using BSCCO wire. The current limiting performance of the proposed SFCL was investigated by the basic tests in the single-phase experimental circuit [3],[7], [8].

In this paper, the power system characteristics, in particular Recovery Characteristics under Load condition (RUL), of the proposed SFCL with rewound structure were investigated. Experiments were carried out by use of the model SFCL in a laboratory scale model power system (one-machine and infinite bus system) assuming the relay sequence.

2. Proposed SFCL with rewound coil

2.1. Current limiting impedance

The SFCL has two coaxially wound superconducting coils. The primary coil is connected to a power system and the secondary coil is short-circuited. The secondary coil has less turns than the primary coil. While both coils are in the superconducting state (stand-by mode), the current of the secondary coil is induced by that of the primary coil to cancel the magnetic flux so that the total stored energy of the coil system is minimized. Therefore, the reactance of the SFCL is very small in stand-by mode.

When a fault occurs in the power system, the fault current flows through the primary coil and the induced current of the secondary coil becomes large. While the secondary coil current exceeds the critical current of the superconducting wire, the secondary coil turns into the normal state and the resistance of the secondary coil (R_2) appears. Then, the current of the secondary coil becomes small. So the magnetic field is no longer cancelled and the impedance of the SFCL (Z_{SFCL}) appears [1]. The impedance Z_{SFCL} has mainly reactance component (L-type) and its saturated value is ωL_1 , where L_1 is the inductance of the primary coil. When the fault current is much larger and exceeds the critical current of the primary superconducting coil wire, the primary coil wire also turns into the normal state. So the resistive component is added to the impedance Z_{SFCL} (L+R type).

There are three different requirements in designing the SFCL. First, the SFCL must have appropriate inductance of the primary coil (L_1) for fault current limiting. Second, the smaller inductance of the secondary coil (L_2) is desirable. Because larger the ratio R_2/L_2 is, larger the limiting impedance Z_{SFCL} is. Third, the large resistance of the primary coil (R_1) is desirable large in order to get large R_{SFCL} .

2.2. Rewound Coil

For normal single solenoid coil, large resistance R_2 requires a long HTS wire, and consequently the inductance L_2 becomes large. To make larger the ratio R_2/L_2 is difficult. But the rewound coil may get large ratio R_2/L_2 . The rewound coil structure has two coils having different diameter (inner and outer coils), which are wound by the superconducting wire in the same direction and connected each other (short-circuited).

The inductance of the secondary rewound coil depends on the magnetic flux between the inner and outer coil. As the magnetic fluxes due to the inner and outer coils are cancelled, to a certain extent, each other, the rewound coil can get large resistance and small inductance, in other words, can get large ratio R_2/L_2 .

The primary coil must be designed as the similar rewound coil with larger turn number, because the magnetic field made by both the primary and the secondary rewound coils should be almost the same for canceling their remaining magnetic fluxes between inner and outer bobbins each other. The remaining magnetic flux in the system is quite small in the stand-by mode.

2.3. Model SFCL [7]

Specification of BSCCO wire is indicated in Table 1. The critical current I_c of BSCCO wire is 100 A. The cross-section of the transformer type SFCL having rewound structure was represented in Fig. 1. It consists of two rewound coils, that is, the primary and secondary coil. The primary coils were directly wound on two bobbins made of fiber-reinforced plastics (FRP). The secondary coils were wound on the primary coils isolated by Kapton tape.

The whole image of the transformer type SFCL with rewound structure is shown in Fig. 2. The primary inner and outer coils were connected at their bottoms. The other ends of them connected to the power line. The secondary inner and outer coils were soldered together for almost half turn both at top and bottom ends. The specifications of the transformer type SFCL having rewound structure is shown in Fig. 1.

Fig. 3 shows the impedance of the SFCL having rewound structure calculated from the peak values of the voltage across and the current through the SFCL [7]. The horizontal axis indicates the voltage of the test circuit, which is corresponding to the fault current. The impedance increases with voltage in two stages that is, for small fault current, mainly the reactance component increases, and for large fault current, the resistance component becomes larger.

Table 1. Specification of BSCCO wire used.

Sumitomo CT-OP BSCCO wire (SCA02-2006-020)	
Materials	silver sheathed BSCCO
Width	4.3 mm
Average Thickness	0.22 mm
I_c (77K, Self Field)	100 A
n-value (77K, Self Field)	21
Silver ratio	2.5

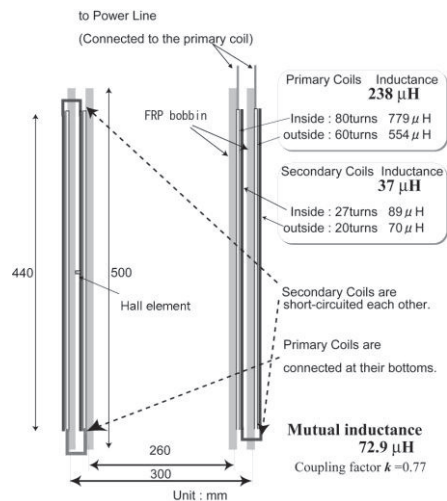

Fig. 1. Cross section of the SFCL having rewound structure



Fig. 2. Photo view of the model SFCL.

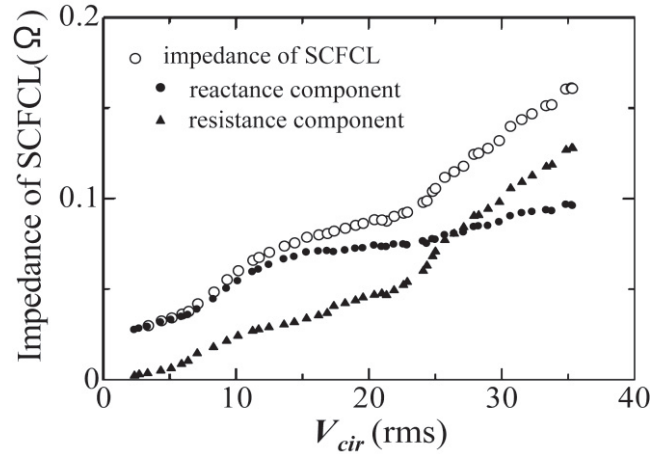

Fig.3. impedance of the model SFCL.

3. Experiment

3.1. Experimental system

The experiments of the transformer type SFCL having rewound structure were carried out in a laboratory scale power system (one-machine and infinite bus system). Fig. 4 shows the experimental circuit. It consists of a three-phase synchronous generator, reactors (L_t : 1.85 mH, transmission lines: 12.8 mH), an infinite bus, switches (SW1, SW2, and SW3), and the SFCL. The synchronous generator was connected to the infinite bus (AC 210 V, 50 Hz) through parallel artificial transmission lines.

The SFCL was immersed in the liquid nitrogen and installed in series to the generator. The inductance of the SFCL in stand-by mode was 65 μ H. The current I_{fcl} through the SFCL and the voltage V_{fcl} across the SFCL were measured. The current I_2 of the secondary short-circuited coil was also measured by use of Rogowski coil. In addition, the excitation voltage V_f and the field current I_f of the generator were measured.

One line grounded fault (1LG) was considered. The SFCL was installed only in the fault phase, and the reactors whose inductance was equivalent to that of the SFCL (65 μ H) in stand-by mode were put in the other phases for three-phase equilibrium. In order to clear the limiting effect of the SFCL, the same experiments without the SFCL were carried out where the equivalent reactors were installed to every phase line in place of the SFCL.

3.2. Switching sequence

The magnetically controlled switches SW1 and SW2 simulated circuit breakers (C.B.s). The single line grounded fault (1LG) was simulated in the lower line (fault line) by closing SW3. The sequence of the switches is shown in Fig. 5. Normally, SW1 and SW2 are closed for a double line transmission.

Single line ground fault occurs by closing SW3 and after 100 ms the fault line is rejected by opening SW1 and SW. During the single line transmission, the fault is eliminated, and they are re-closed to recover the initial state. The second similar fault occurs after 700 ms of the re-closure, and the switches are operated in the same manner as at the first fault.

Throughout the sequence, the generator continues to operate and the current limiting performance of the SFCL was evaluated under load condition.

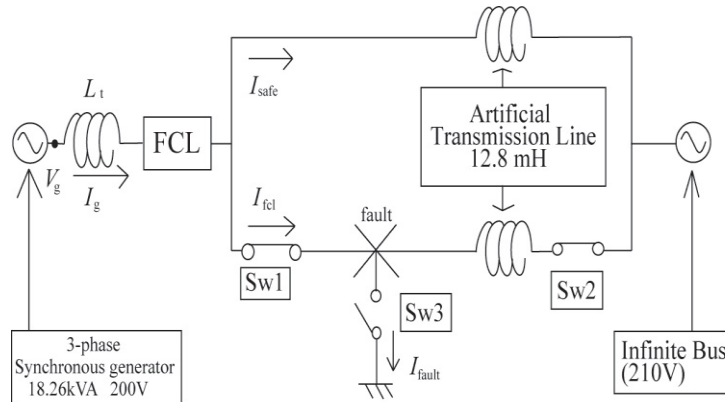

Fig. 4. Experimental circuit

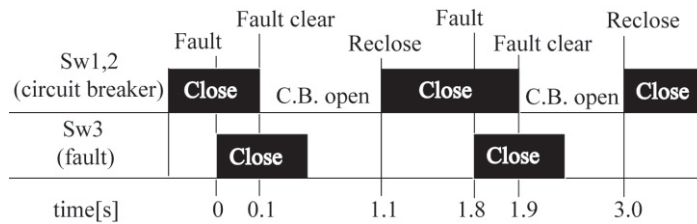

Fig. 5. Switch sequence

4. Experimental results and discussion

Fig. 6 shows the experimental results before and after the two faults, that is, the wave forms of current through the secondary coil I_2 , current through the primary coil I_{fcl} and voltage across the SFCL V_{fcl} , from top to bottom. The first fault and the second one occurred at about 0 s and 1.7 s, respectively.

To compare the wave forms of the first fault and that of the second fault, the zoomed-up wave forms during the fault were shown in Fig. 7.

As seen from Fig.6, the primary and the secondary coil current, I_{fcl} and I_2 , exceed their critical current. The FCL limited the fault current with 230 Apeak (prospective 560Apeak without FCL) successfully and the FCL voltage V_{fcl} appeared. After the first fault clear, the FCL voltage recovered about 0V, even while the current I_{fcl} continued to flow.

So it is confirmed that the model SFCL recovered quickly under load condition. Additionally, at the following second fault, almost same current limiting performance was confirmed as shown in Fig.7.

Consequently, the model SFCL can recover quickly under load condition and can operate repetitively.

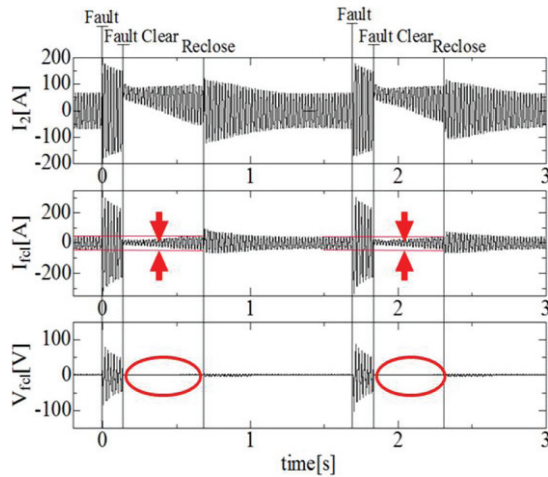

Fig. 6. Experimental results before and after two faults

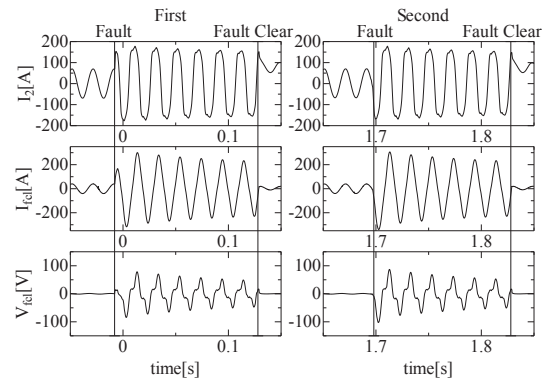

Fig. 7. Waveforms of the SFCL in the first and second fault

5. Conclusion

The current limiting performance and recovery characteristics of the transformer type SFCL with rewind structure were investigated experimentally. The experiments were carried out in a laboratory scale power system which is one-machine (18kVA, 220V) and infinite bus through double line transmission lines. The model proposed SFCL was installed in series to the generator.

Both primary and secondary coils of superconductor transformed normal state and the model SFCL limited fault current and suppressed the over current and the voltage drop of the generator. During the switch sequence, the generator continued to produce the electric power and the SFCL limited the fault current under load (without any rejection).

After limiting operation, the model SFCL recovered quickly under load condition. Even in the repetitive fault condition (interval is 700 ms), it is confirmed that the model SFCL can operate repetitively without any degradation in current limiting performance.

References

- [1] K. Fushiki, et al., *IEEE Trans. on Applied Superconductivity*, Vol. 17, No. 2, pp. 1815–1818, June 2007.
- [2] K. Suzuki, et al., *Journal of Physics. Conference series*, Volume 97, No. 1, p.012293, 2008.
- [3] S. Oda, et al., *IEEE Trans on Applied Superconductivity*, Vol. 21, No. 3, pp 1307-1310.
- [4] Y. Shirai, et al., *IEEE Trans on Applied Superconductivity*, Vol. 18, No. 2, pp 680-683.
- [5] M. Shiotsu, et al., *Advances in Cryogenic Engineering (Materials)*, Vol.44, pp. 623-629.
- [6] H. Okamoto and F. Irie, et al., *IEEE Trans. on Applied Superconductivity*, Vol. 9, No. 2, pp. 2351-2354, June 1999.
- [7] T. Nii, et al., *IEEE Trans. on Applied Superconductivity*, Vol. 19, No. 2, pp. 1892-1895, June 2009.
- [8] Y. Shirai, et al., *Journal of Physics, Conference Series* 234 (2010) 032053.