

CO3-1 Basic Research for Sophistication of High-power Reactor Noise Analysis (II)

S. Hohara¹, T. Sano¹, A. Sakon¹, K. Nakajima², K. Takahashi², K. Hashimoto¹

¹Atomic Energy Research Institute, Kindai University

²Interdisciplinary Graduate School of Science and Engineering, Kindai University

INTRODUCTION: Reactor noise for high-power reactors were actively measured in the 1960's and 1970's. The major focuses of those researches were for the abnormality diagnosis or the output stabilization diagnosis, and almost researchers were in the field of system control engineering or instrumentation engineering. High-power reactor noise measurements for dynamics' analysis of reactivity change, reactivity feedback or reactor characteristics itself were few in the time (1960's and 1970's), because of the powerless measurement system. In this research, we plan to measure KUR's output with present-day measurement system and plan to analyze with several analysis methods. The results of this work will supply some knowledges and technics in the aspect of sophistication of reactor noise analysis or simulation methods.

In this year, we tried to measure the reactor nuclide noise of the critical state KUR core via a 1-inch ³He counter at CN-1 port. The experimental work was done in 7th November 2019. As the result of the experiment, a result looks like the nuclear reactor noise was observed.

EXPERIMENTS: In this experiment, the output signal of the ³He counter was put into a Spectro Scopy AMP (2022: Canberra), and the output of the SSA was measured with a time-series measurement system (HSM-CA4106_LC: ANSeeN Inc.). A schematic view of the measurement is shown in Fig.1, and the counter installation overview is shown in Pic.1.

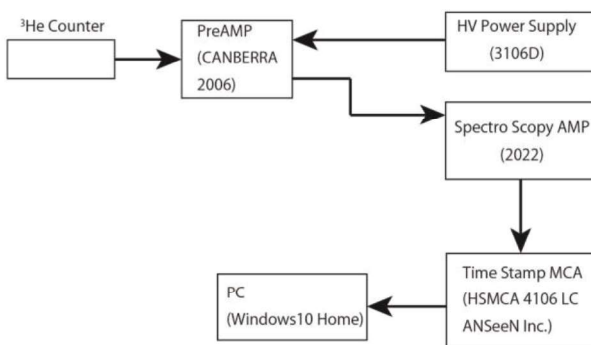

Fig. 1. Schematic view of the measurement.

The experimental condition is shown in Table.1. The reactor Power was set from 20W to 1kW. The measurement time was 800 – 3,600 sec.



Fig. 2. An overview of the counter installation.

Table 1. Experimental condition.

| No. | Reactor Power [W] | Measurement Time [sec] | Count Rate [cps] |
|-----|-------------------|------------------------|------------------|
| 1 | 20 | 800 | 0.54 |
| 2 | 100 | 600 | 2.73 |
| 3 | 300 | 1,000 | 7.92 |
| 4 | 1k | 3,600 | 26.33 |

RESULTS:

The measurement results were analyzed by Feynman- α / bunching method. As a result of the analysis, good results were not obtained for 20W, 100W and 300W. However, a plot shape similar to Feynman's theoretical formula was obtained for 1kW. The analysis result is shown in Fig.3. From the result, the prompt neutron decay constant was 97.7 [sec⁻¹], and γ value was very small (~0.09). From the smallness of the γ value, it is considered necessary to verify whether it is a nuclear noise by other techniques (e.g., covariance to mean ratio method, etc.).

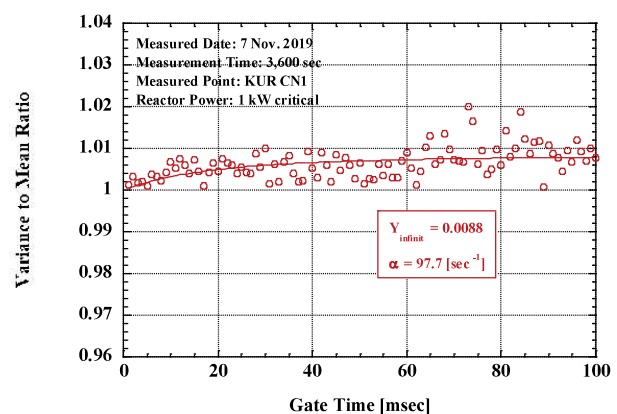

Fig. 3. A Feynman- α /Bunching analysis result for the 1kW KUR operation.

T. Endo¹, K. Watanabe¹, A. Nonaka¹, S. Imai¹, F. Nishioka¹, H. Oike¹, M. Yamanaka², C.H. Pyeon²

¹Graduate School of Engineering, Nagoya University

²Institute for Integrated Radiation and Nuclear Science, Kyoto University

INTRODUCTION: In a general transient in a subcritical system, reactivity, neutron source intensity S , and point kinetic parameters (Λ and β_{eff}) can change simultaneously. For such a simultaneous transient, the subcriticality measurement by the conventional neutron source multiplication method or inverse kinetics method is difficult because S and point kinetics parameters are generally assumed to be constant. To address this issue, we developed the time-domain decomposition-based integral (TDDI) method [1] to measure the subcriticality in dollar units after the transient. Furthermore, for an unknown target system with a steady-state, it is not easy to estimate an absolute value of subcriticality, $-\rho$, without additional information such as detector efficiency, source strength, and preliminary numerical analysis. To roughly estimate $-\rho$ in the stationary unknown system, we have been investigating the third-order neutron correlation technique [2], which is a zero-power reactor noise analysis method using the second- and third-order factorial moments of neutron counts. In this study, advanced subcritical measurements using the TDDI method and third-order neutron correlation technique were conducted to confirm these applicability in subcritical cores at the Kyoto University Critical Assembly (KUCA). This report mainly presents experimental results using the TDDI method.

METHODOLOGY: The TDDI method was proposed using the point kinetics theory based on the fundamental mode approximation. This method assumes that a target subcritical system changes from a steady-state into another steady-state via an arbitrary transient of state change (*e.g.* subcriticality, source strength, and point kinetics parameters) during $t_0 < t < t_1$. Using the measured time variation in neutron count rate $n(t)$ under such a situation, an absolute value of subcriticality in dollar units after the transient ($-\rho_1/\beta_{\text{eff},1}$) can be evaluated by the following formula:

$$\frac{-\rho_1}{\beta_{\text{eff},1}} = \frac{\sum_{i=1}^b \frac{a_i}{\lambda_i} (n_0 e^{-\lambda_i(t_1-t_0)} - n_\infty + \lambda_i \int_{t_0}^{t_1} n(t) e^{-\lambda_i(t_1-t)} dt)}{\int_{t_1}^{\infty} (n(t) - n_\infty) dt}, \quad (1)$$

where n_0 and n_∞ means the stationary neutron count rates before and after the transient; a_i and λ_i represent relative delayed neutron yields and decay constant for i th precursor group. The TDDI method has advantages to approximately estimate the subcriticality without the following information: (1) the reference subcriticality $-\rho_0$ before the transient, (2) the absolute values of neutron source intensity and the point kinetics parameters before and after the transient, and (3) the time variation in them. The statistical error of $-\rho_1/\beta_{\text{eff},1}$ using the TDDI method can be approximately estimated using the random sampling

method [1] with the assumption where the probability distribution of neutron counts approximately follows the Poisson distribution.

EXPERIMENTS: The subcritical transient experiments were carried out in a deep subcritical core (A(1/8”p60EUEU(3)+1/8”p10EUEU<EUEU-AIAI-NU-AIAI-EUEU>)) driven by a spallation neutron source, which was generated by colliding a 100MeV proton beam from the FFAG accelerator with a Pb-Bi target. All control and safety rods were fully inserted. Time series data of neutron count rate, $n(t)$, was continuously measured using neutron detectors (LiFCaF and LiF/Eu:CaF₂ fiber-type detectors (#1,4) in the core region and BF₃ counters (#1,3,4) in the polyethylene reflector region) with list-mode data acquisition systems. First, the subcritical core was kept under the steady-state driven by the spallation source to obtain the stationary count rate n_0 before the transient. Second, a ramp-wise transient was given by withdrawing 3×3 fuel and reflector assemblies in approximately 15 seconds. Thereby, not only the subcriticality but also point kinetics parameters simultaneously changed over the withdrawing time. After the transient, the core was kept as-is for a sufficiently long time until the subcritical core reached another steady-state to measure stationary count rate n_∞ after the transient. Based on Eq. (1), $-\rho_1/\beta_{\text{eff},1}$ was estimated from the measured $n(t)$. For comparison, the subcriticality using the conventional integral method was also estimated.

RESULTS: Figure 1 shows experimental results of $-\rho_1/\beta_{\text{eff},1}$ by the conventional integral and TDDI methods for five neutron detectors, and the numerical result by MCNP6.2 with ENDF/B-VII.1 (10.20±0.08 [\$]). In the case of the conventional integral method, $-\rho_1/\beta_{\text{eff},1}$ values were significantly underestimated compared with the MCNP6.2 result, and these differences were larger than the statistical errors. On the other hand, $-\rho_1/\beta_{\text{eff},1}$ of the TDDI method well agreed with the MCNP6.2 result. Consequently, the applicability of the TDDI method was demonstrated through this KUCA subcritical transient.

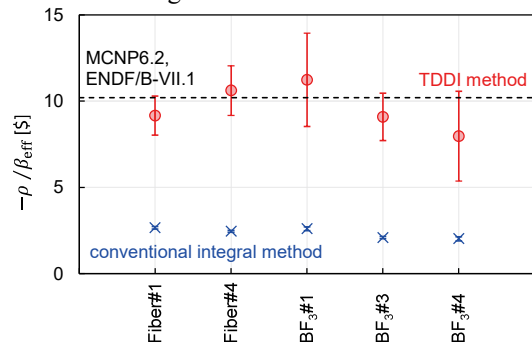

Figure 1. Experimental results of TDDI method.

REFERENCES:

- [1] T. Endo, *et al.*, J. Nucl. Sci. Technol., (2019). DOI:10.1080/00223131.2019.1706658
- [2] T. Endo, *et al.*, J. Nucl. Sci. Technol., **56** (2019) 322–336.

CO3-3 Measurement of Gamma Ray from Short Lived Fission Product under Background of Fission Prompt Gamma Ray

Y. Nauchi, Y. Takahashi¹, T. Sano², H. Unesaki¹, J. Hori¹, and K. Kusumi

Nuclear Technology Research Laboratory, Central Research Institute of Electric Power Industry.

¹*Kyoto University Institute for Integrated Radiation and Nuclear Science*

²*Atomic Energy Research Institute, Kindai University*

INTRODUCTION: Accurate estimation of isotopic compositions of nuclear fuel material is desired for the criticality safety and the safeguards. For a small amount of sample, the delayed γ ray analysis (DGA) has been studied in which γ rays from fission products (FPs) are measured [1]. Since the yield ratio of FPs varies with fission nuclides, the ratio of ^{235}U , ^{238}U , ^{239}Pu , and ^{241}Pu might be obtained by measurements of γ ray spectra from the FPs generated by neutron irradiation. The ratio is rather invariant with the neutron multiplication factor. To explore the applicability of DGA for nuclear materials where the fission reaction chain is significant, DGA for a critical core was conducted using the KUCA C-core.

EXPERIMENTS: For DGA, a HP-Ge detector must be used to distinguish γ rays from FPs. The detector should be shielded from neutron irradiation since γ rays from neutron capture reactions and activated nuclides inside the detector become a serious background. To shield the detector, we decided to put the detector outside the reflector of the critical core. To take a massive shield, we choose to use the C-core where fuel assemblies are surrounded by light water reflector. On position 20.5 cm outside the port of the core tank, a HP-Ge detector of 35 % relative efficiency was set as shown in Fig. 1. In the tank, 12 assemblies of C35 were loaded. The thickness of the water layer between the fuel and the port window was 60.4 cm. The control rods and reactor instrumentation systems (FC#1~3 and UIC#4~6) were placed outside the region between the fuel assemblies and the detector. The neutron irradiation was conducted at low power where the pulse counting type fission chambers (FC#1~3) are available. To attain criticality at low power level easily, the FC#1 was placed 7 cm near to the fuel compared to a conventional case. The γ rays were measured in the critical condition and posterior to the control rod drop.

RESULTS:

The γ ray spectrum in the critical condition is shown in Fig. 2. The count rate was 9 ~ 11 kcps and the dead time was 10 ~ 13 %. In the spectrum, structures corresponding to interactions of neutron inside the HP-Ge detector were not found so that the neutron shield by the water layer of the 60cm thickness and low core power setting were proven to be successful. In the pulse height region from 2.5 to 5.0 MeV, the count rate is dominated by the continuum component of fission prompt γ rays. Above that, γ rays from capture reactions and short-lived FPs are found.

Referring to the JENDL/FPY & FPD-2011[2], intense γ ray emissions from FP were listed up. By a comparison, ^{88}Br , $^{90, 90\text{m}}$, ^{91}Rb , $^{95, 97}\text{Y}$, ^{95}Sr and ^{136}Te were identified.

Posterior to the control rod drop, γ rays from short-lived FP of which half-life less than 1 min were not identified due to the background prompt γ rays from fission reaction chain initiated by the delayed neutron emission. Even in the rod dropped condition, a delayed neutron might induce more than 10 fission so that the prompt γ ray emission was significant. Besides, activity of the precursor attenuates with half-life of 56 s (^{87}Br). For the reason, γ rays from FP of shorter half-life becomes difficult to be measured.

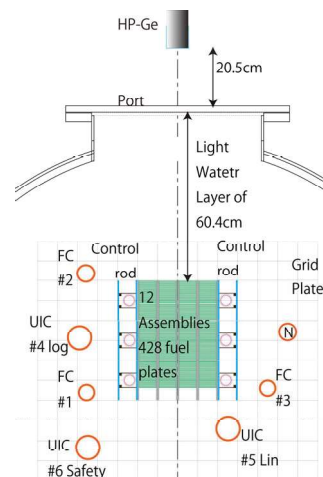

Fig. 1 Experimental setup

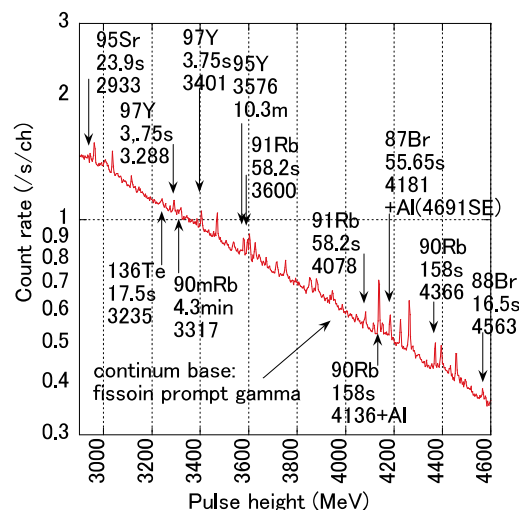

Fig. 2 γ rays from short lived FP measured for critical core (C35 U-assembly)

REFERENCES:

- [1] M. Koizumi, F. Rossi, D. C. Rodriguez *et al.*, *EPJ Web Conf.*, **146** (2017) 09018.
- [2] J. Katakura JAEA-Data/Code 2011-025, 2012.

CO3-4 Reactor Noise Power-Spectral Analysis for a Graphite-Moderated and -Reflected Core (II)

A. Sakon, K. Hashimoto, S. Hohara, K. Nakajima¹, K. Takahashi¹, T. Sano¹, Y. Fukaya², N. Fujimoto³, and Y. Takahashi⁴

Kindai University Atomic Energy Research Institute
¹Graduate School of Science and Engineering, Kindai University
²Sector of Fast Reactor and Advanced Reactor Research and Development, Japan Atomic Energy Agency
³Faculty of Engineering, Kyushu University
⁴Institute for Integrated Radiation and Nuclear Science, Kyoto University

INTRODUCTION: In the last study, the prompt neutron decay constants measured by the detectors about 30cm and 35cm away from core region agreed with the calculated results by the continuous-energy Monte Carlo code MVP version 3[1]. The location of these detectors is farther than the location in the light water moderation reactor. The objective of this study is experimentally to confirm a high flexibility of neutron detector placement in graphite reflector for reactor noise analysis.

EXPERIMENTS: The core configuration is shown in Fig. 1. “F” denoted a low-enriched fuel assembly, whose average enrichment is 5.41wt%. “D” is a driver highly-enriched fuel assembly. “G” is graphite reflector. Orange cell is polyethylene reflector. “1”, “2”, “3”, and black dots are BF₃ proportional neutron counters. Withe dot is ³H proportional neutron counter. These counters are 1.0 in. diameter and 15.47 in. length. In a critical state, reactor noise analysis was carried out using BF₃ detector “1”, “2”, and “3”. The distance from core region to detector “1” is about 20cm, that to detector “2” is about 35cm, that to detector “3” is about 55cm.

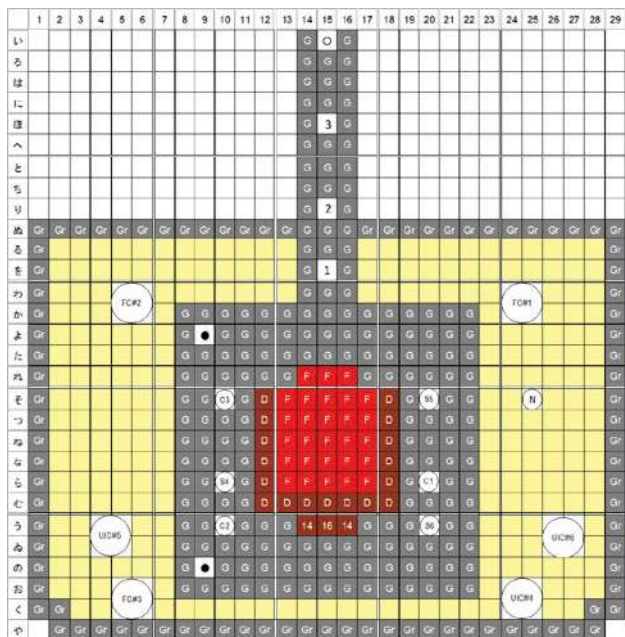

Fig. 1 Core configuration (B7/4”G2/8”p8EUNU+3/8”p38EU)

Reactor noise analysis by power spectrum method was performed in the critical state of suitable reactor power for each detector. The reactor power during measurement was adjusted so that the count rate of each detector was about 3,000[cps].

RESULTS: The auto power spectral densities by detector “2” and detector “3” are shown in Fig. 2 and Fig. 3, respectively. These figures also include least-squares fits of a conventional formula [2] to the spectral densities to determine the prompt-neutron decay constant α_0 (β_{eff}/Λ), where the fitting was confined to a frequency range from 1.25 to 100 Hz. The derived decay constant of detector “2” was 65.8 ± 3.4 [1/s], which was about the same as that the graphite core of last year. However, the derived decay constant of detector “3” was 96.3 ± 14.3 [1/s]. In order to obtain the prompt-neutron decay constant using a detector more than 35cm away from core regions, it is necessary to efficiently measure neutrons that information on fission reaction.

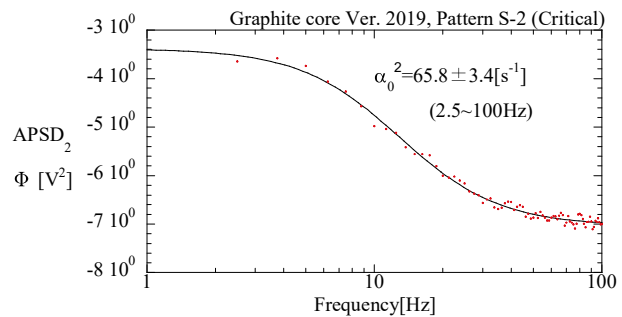

Fig. 2 Auto-Power Spectral Density (Detector “2”)

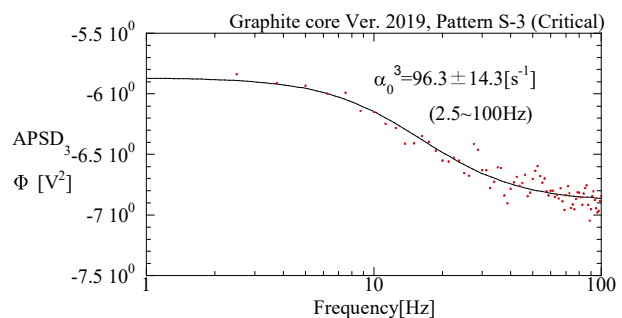

Fig. 3 Auto-Power Spectral Density (Detector “3”)

REFERENCES:

[1] Y. Nagaya, K. Okumura, T. Sakurai and T. Mori, MVP/GMVP Version 3 : General Purpose Monte Carlo Codes for Neutron and Photon Transport Calculations Based on Continuous Energy and Multigroup Methods, Tokai-mura: Japan Atomic Energy Agency; 2017, (JAEA-Data/Code 2016-018).
 [2] M. M. R. Williams, Random Processes in Nuclear Reactors, (Pergamon Press, Oxford,1974), section 3.6.

CO3-5 Measurement of fundamental characteristics of nuclear reactor at KUCA (IV)

Y. Kitamura¹, T. Misawa¹, M. Szieberth² and G. Klujber²

¹*Institute for Integrated Radiation and Nuclear Science, Kyoto University*

²*Institute of Nuclear Techniques, Budapest University of Technology and Economics*

INTRODUCTION: The reactor noise methods can measure the subcriticality through determination of the prompt neutron decay constant. Owing to a great amount of efforts devoted by many researchers, they are now regarded to be one of the most established methods. However, these methods still have one serious problem; the dead time effect that deteriorates the information from the neutron detector and disables the conventional theoretical formula. In 2014, Kitamura and Fukushima hence derived theoretical formulae of two major methods, i.e., Feynman- and Rossi-alpha ones by rigorously considering the dead time effect[1]. However, unfortunately, it was found that their formulae are too complicated to practically apply. Hence, in the present study, another technique for overcoming the dead time effect and its experimental investigation performed at the KUCA are reported.

METHOD: In the Feynman-alpha method, neutron detection signals from the neutron detector arising within a certain length of the time interval, i.e., the gate width, are counted. By using thus obtained neutron counts, a correlation index Y is calculated to quantify the temporal fluctuations in neutron population in the subcritical multiplying system. The neutron counts with respect to various gate widths are further obtained to calculate the Y values as a function of the gate width, i.e., the Feynman- Y curve. This curve is fitted by the theoretical formula of the Feynman-alpha method to infer the prompt neutron decay constant. However, under high counting-rate conditions, the Y values with respect to shorter gate widths take negative values as shown in Fig. 1. Owing to this fact, the prompt neutron decay constant inferred under such conditions is biased.

In Fig. 2, a couple of neutron detection signals (red and blue dashed lines) overlapping with each other are shown. In the conventional technique, these signals are regarded to be one signal. On the other hand, in the present technique, before counting the neutron detection signals, the overlapped signals (yellow dots) are resolved. To realize such an analysis, in the present technique, a row signal wave-form recording system is introduced.

RESULTS: In Fig. 3, the Feynman- Y curve after resolving overlapping signals is shown. One sees that even the Y values with respect to short gate widths take positive values.

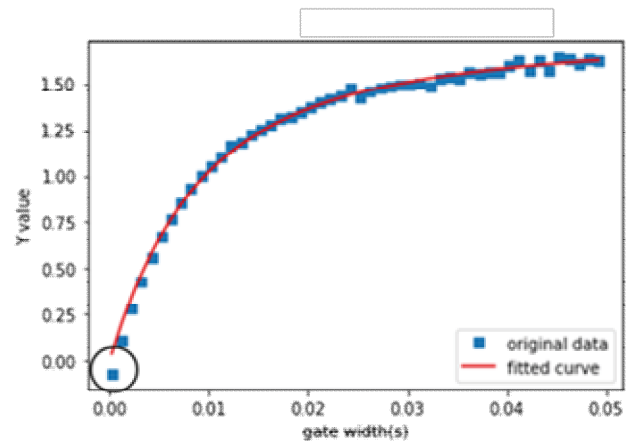

Fig. 1: Example of conventional Feynman- Y curve.

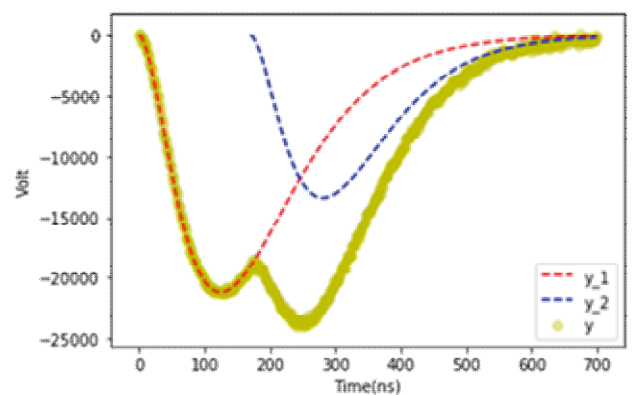

Fig. 2: Signal resolving by wave-form analysis.

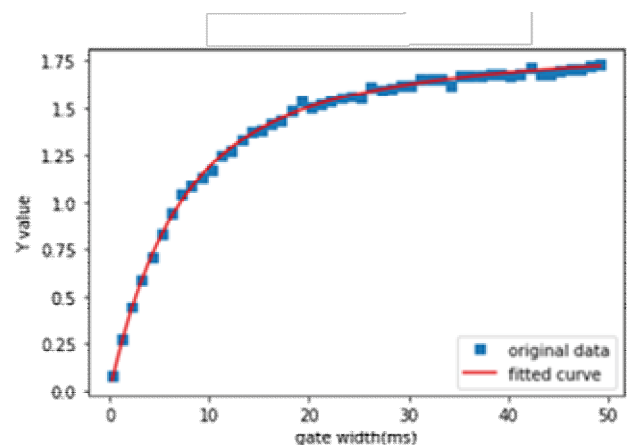

Fig 3: Example of present Feynman- Y curve.

REFERENCES:

[1] Kitamura, Y., Fukushima, M, J. Nucl. Sci. Technol., 51, 766 (2014).

CO3-6 Reactor Physis Experiment in Graphite Moderation System for HTGR (II)

Y. Fukaya, S. Okita, K. Takahashi¹, K. Nakajima¹, A. Sakon¹, T. Sano¹ and Y. Takahashi²

Sector of Fast Reactor and Advanced Reactor Research and Development, Japan Atomic Energy Agency

¹Kindai University Atomic Energy Research Institute

²Institute for Integrated Radiation and Nuclear Science, Kyoto University

INTRODUCTION: To introduce noise analysis technique to High Temperature engineering Test Reactor (HTTR), noise measurement is performed based on B7/4”G2/8”p8EUNU+3/8”p38EU(3) core composed in the B-rack of Kyoto University Critical Assembly (KU-CA). In the previous experiment performed last year, the neutron source was set to out of core. In the present experiment, the neutron source of Cf was loaded into a fuel assembly.

EXPERIMENTS: The core configuration is shown in Fig.1. First, the fuel assembly with neutron source was loaded into the center of the core at T15 to mimic the power distribution in criticality. Second, that was loaded into the edge of the core at G15 to mimic the power distribution of the HTTR in subcriticality and neutron leak-age directly to the neutron detectors. In this case, the BF3 detector was moved from I15 to O21. In this report, the first case is called “criticality mimicked case”, and the second case is called “HTTR mimicked case”. The reactor noise driven by inherent neutron source was also measured and is called “inherent neutron source case.”

For these data, we apply Feynman- α method to observe sub-criticality. The control rods pattern and subcriticality is listed in Table 1.

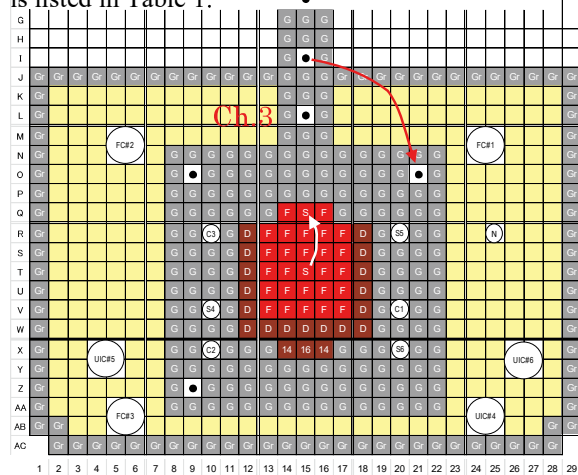

Fig. 1. Core configuration.

Table 1 Control rods pattern and subcriticality

| Pattern | Control Rod Position | | | | | | Center Core | Subcriticality [-% $\Delta k/k$] |
|---------|----------------------|------|------|------|------|------|-------------|-----------------------------------|
| | C1 | C2 | C3 | S4 | S5 | S6 | | |
| A | U.L. | U.L. | L.L. | S.L. | U.L. | U.L. | U.L. | 0.438 |
| B | L.L. | U.L. | U.L. | U.L. | U.L. | U.L. | U.L. | 0.857 |
| C | L.L. | U.L. | L.L. | U.L. | U.L. | U.L. | U.L. | 1.364 |
| D | L.L. | L.L. | L.L. | U.L. | U.L. | U.L. | U.L. | 1.848 |
| E | L.L. | L.L. | L.L. | L.L. | L.L. | L.L. | U.L. | 3.229 |
| F | L.L. | L.L. | L.L. | L.L. | L.L. | L.L. | L.L. | 4.882 |

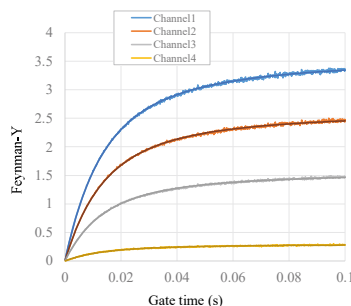

Fig. 2 Feynman-Y for inherent neutron source case with the control rod pattern of B.

RESULTS: To determine the prompt neutron decay constant, Feynman-Y is evaluated and the curve is fitted to an analytical formula by non-linear least square method as shown in Fig. 2. In general, the plotted Feynman-Y shows a good agreement with the analytical formula. The results are summarized in Tables 2, 3 and 4, respectively for the inherent neutron source case, criticality mimicked case, and HTTR mimicked case. Here, we focus on Ch.3 to observe directly detected neutron effect.

Comparing those result, the characteristics is found as follows:

- Generally, the inherent neutron source cases show a good agreement with the subcriticality measured by rod drop method listed in Table 1 without depending on the subcriticality. It is supposed that the neutron source distributes similar to the power distribution in criticality.
- With the external neutron source cases, *that is* criticality mimicked case and HTTR mimicked case, the subcriticality shows slight different with the shallow subcriticality control rod pattern.
- In the HTTR mimicked case, the difference is slightly larger than that in the criticality mimicked case. It is guessed that the error is caused by the directly detected neutron from the neutron source.

Table 2 Decay constant and subcriticality of inherent neutron source case

| CR pattern | Channel | Decay constant (s^{-1}) | Subcriticality (-% $\Delta k/k$) |
|------------|---------|-----------------------------|-----------------------------------|
| C | Ch.3 | 167.8 \pm 0.9 | 1.250 \pm 0.011 |
| D | Ch.3 | 239.4 \pm 1.8 | 2.105 \pm 0.021 |
| E | Ch.3 | 343.6 \pm 4.9 | 3.349 \pm 0.059 |

Table 3 Decay constant and subcriticality of criticality mimicked case

| CR pattern | Channel | Decay constant (s^{-1}) | Subcriticality (-% $\Delta k/k$) |
|------------|---------|-----------------------------|-----------------------------------|
| C | Ch.3 | 183.2 \pm 1.1 | 1.434 \pm 0.013 |
| D | Ch.3 | 215.2 \pm 2.3 | 1.816 \pm 0.027 |
| E | Ch.3 | 381.5 \pm 7.7 | 3.801 \pm 0.424 |

Table 4 Decay constant and subcriticality of HTTR mimicked case

| CR pattern | Channel | Decay constant (s^{-1}) | Subcriticality (-% $\Delta k/k$) |
|------------|---------|-----------------------------|-----------------------------------|
| C | Ch.3 | 191.8 \pm 2.0 | 1.537 \pm 0.023 |
| D | Ch.3 | 254.7 \pm 2.9 | 2.288 \pm 0.034 |
| E | Ch.3 | 374.2 \pm 9.7 | 3.715 \pm 0.116 |

CO3-7 Sample worth measurements of Lead and Bismuth in low-enriched uranium region at A-core of KUCA for ADS

M. Fukushima¹, A. Oizumi¹, M. Yamanaka² and C. H. Pyeon²

¹Nuclear Science and Engineering Center, Japan Atomic Energy Agency

²Institute for integrated Radiation and Nuclear Science, Kyoto University

INTRODUCTION: The Japan Atomic Energy Agency (JAEA) has investigated neutronics of the accelerator-driven system (ADS) of a lead bismuth eutectic (LBE) cooled-tank-type core to transmute minor actinides discharged from nuclear power plants. For the design study of ADS, integral experimental data of nuclear characteristics of LBE is necessary to validate cross sections of lead (Pb) and bismuth (Bi). Previously, Pb and Bi samples experiments were performed in a high-enriched uranium (HEU) core [1]. In present study, a similar experiment was conducted in a variation of uranium core with a low-enriched uranium region.

EXPERIMENTS: The reference configuration had five test rods as shown in Figure 1. Figure 2 shows each test unit composed of two EU plates (1/16 inch×2), two Al plates (1/16 inch×2), a natural uranium plate (1.05 mm), two Al plates and two EU plates. The unit-averaged ²³⁵U enrichment was about 17%. The test units were axially and radially surrounded by normal fuel units composed of two EU plates and a polyethylene plate.

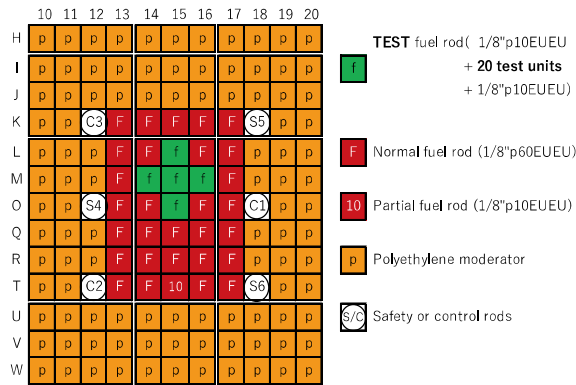

Figure 1. Reference configuration.

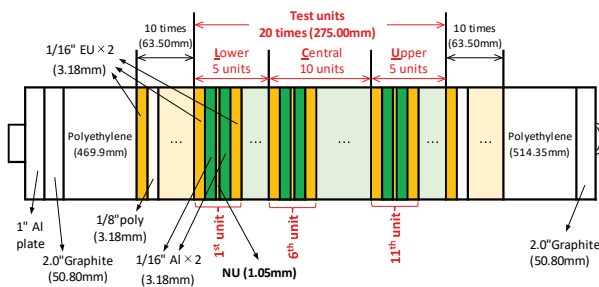

Figure 2. Schematic drawing of test fuel rod.

In the previous experiments for sample worth, solid Al plates were replaced with Pb (or Bi) plates, so aluminum cross sections should be considered as well as lead one (or bismuth) when verifying them. Instead, we used Al voided spacers with a low density that was about 1/10 that of solid Al plates to reduce the aluminum component. For the Pb sample worth, Pb plates instead of Al ones (See Figure 2) were installed in five test rods beforehand, and after then the Pb plates in the central 10 units were replaced with Al voided spacers. The Pb sample worth was estimated as difference excess reactivities before and after the replacement. The other patterns were summarized together with experimental results in Table 1.

Table 1 Experimental results.

| Case | Pattern (U/C/B) ^{*1} | Excess reactivity (pcm) | Sample worth (pcm) |
|------|-------------------------------|-------------------------|--------------------|
| A | Pb/ Pb/Pb | 280.3 ± 6.5 | Pb sample (A-B) |
| B | Pb/ V ^{*2} /Pb | 116.1 ± 2.1 | 164.2 ± 6.9 |
| C | Bi/ Bi/Bi | 228.8 ± 6.6 | Bi sample (C-D) |
| D | Bi/ V ^{*2} /Bi | 75.6 ± 0.9 | 153.2 ± 6.7 |
| E | Al/ Al ^{*3} /Al | 152.4 ± 5.6 | Al sample (E-F) |
| F | Al/ V ^{*2} /Al | 33.0 ± 5.6 | 119.4 ± 8.0 |

^{*1}(Upper 5 units / Central 10 units / Lower 5 units) of test regions.

^{*2}V indicates Al voided spacer. ^{*3}Al indicates solid Al plate.

RESULTS: Numerical analyses were preliminary conducted with MCNP6.1 together with JENDL-4.0 (J40) and ENDF/B-VII.1 (B71). The sample worth was estimated as the difference of the effective multiplication factors between the sample-loaded and reference configurations, without considering the criticality bias. Figure 3 shows that the calculations agree with experiment for the Bi and Al sample worth. On the other hand, the calculations overestimate for the Pb sample worth. In FY 2020, the re-measurement is planned also in HEU core by the same method using Al voided spacers.

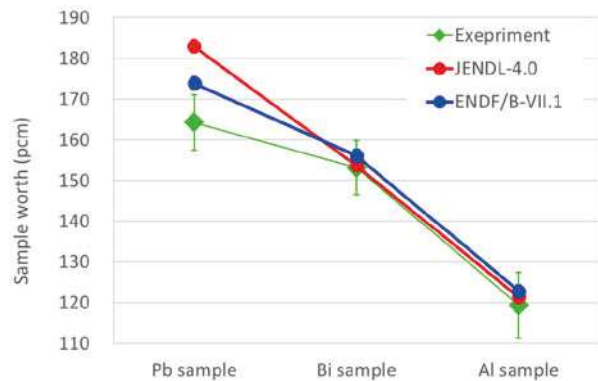

Figure 3. Results of sample worth.

REFERENCES:

[1] C. H. Pyeon, et al., J. Nucl. Sci. Technol., **53**, 602-612 (2016) and **55**, 1324-1335 (2018).

T. Misawa¹, Y. Kitamura¹, T. Takahashi¹ and A. Yasui²

¹Inst. Integrated Radiation and Nucl. Sci., Kyoto Univ.
²Graduate school of Energy Science, Kyoto Univ.

INTRODUCTION: Subcriticality monitoring system has to be used to detect criticality approach for each step of debris removal in Fukushima Daiichi nuclear power plant. For this purpose, International Research Institute for nuclear Decommissioning (IRID) is developing criticality control techniques for fuel debris removal based on neutron noise analysis using Feynman-alpha method. A prototype of the sub-criticality monitoring system was tested to verify applicability on various sub-criticality measurement conditions.

For this measurement, a small neutron detector based on a SiC with boron coated film is one of the candidates at Fukushima because of its toughness against radiation exposure and low detection efficiency for gamma-ray. We are also developing a data transfer system from this SiC neutron detector to data acquisition system which is placed at outside of a reactor vessel by a specially designed optical fiber with high resistance against radiation. In this research, we used this new data transfer system which will be connected to a small neutron detector to measure subcriticality.

EXPERIMENTS: Experiment was carried out at KUCA solid moderated core, B-core, as shown in Fig.1 whose main fuel assembly was 2/8”p23EUEU with relatively hard neutron spectrum. This core was aimed to simulate widely spread fuel debris. The fuel coupon plates were sandwiched with polyethylene plates and assemblies were surrounded by polyethylene reflector to simulate water and some part of the core was assembled with graphite region to simulate less water region which might be appeared during fuel debris digging process. This core was in subcritical state whose k-eff was approximately 0.89 and in steady state with Cf-252 neutron source inserted in a fuel assembly. Data transfer system is illustrated in Fig.2. Boron-lined neutron detector was inserted in a periphery fuel region whose neutron detection analog signal was transfer pre-amplifier and then a data sender system by a co-axial cable. In the data sender system, analog signal was changed to optical digital signal and it was transferred to the data receiver system located at outside of the reactor room by a thin and long quartz optical fiber cable. Then digital data was changed to analog data in the data receiver system and finally neutron detection time whose time bin was 1 micro-second was transferred to PC by USB cable and stored in PC.

DATA ANALYSIS: Neutron detection time stamp data stored in PC were analyzed by the neutron noise analysis methods, Feynman-alpha method (shown in Fig.3) and

Rossi-alpha method.

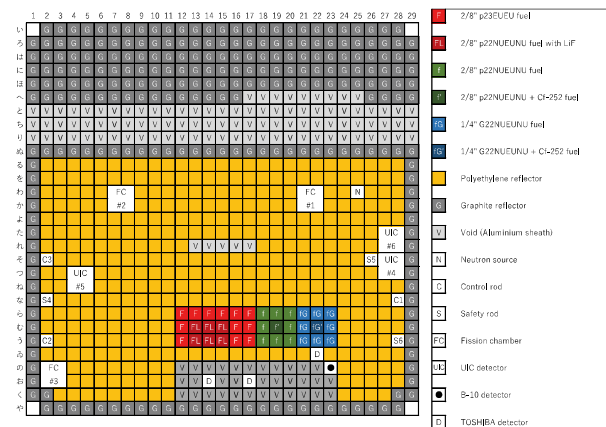

Fig.1 Core configuration of B-core.

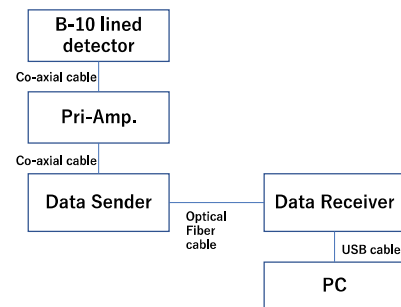

Fig.2 Data transfer system

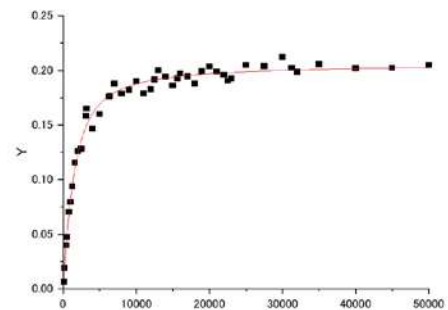

Fig.3 Example of Feynman-alpha result

RESULTS: As shown in Fig. 3, Y-values can be fitted by the theoretical formula (red line) and prompt neutron decay constant (alpha value) can be obtained by the least square fitting method. By Feynman-alpha and Rossi-alpha methods, alpha value was 1110+/- 44 (1/s) and 1250+/-24 (1/s), respectively, and we are now comparing those results with calculated ones by a computer code. We are planning to use this data transfer system combined with a SiC neutron detector next year.

Y. Yamane, S. Araki, Y. Kitamura¹, T. Misawa¹

Japan Atomic Energy Agency

¹Institute for Integrated Radiation and Nuclear Science,
Kyoto University

INTRODUCTION: The estimation of reactivity of an amount of unknown fissile material is one of important issues in the field of criticality safety.

JAEA has been theoretically developing a method to estimate the reactivity and composition of fissile isotope from neutron count rate alone[1-2]. The method is based on a newly developed equation of power in quasi-steady state after prompt jump/drop of power due to reactivity and/or neutron source change[3].

The purpose of the experiment is to obtain the experimental data for the verification and validation of the developed method. This time, a fixed intensity neutron source was used under shallow subcritical conditions, and an improved method which utilize the equation of power as it is, not its integral, was applied to the measured neutron count rate data.

EXPERIMENTS: A subcritical core was made by removing fuel elements from the basic critical core configuration known as 3/8" p36EU of A-core. The Am-Be was used as the external neutron source.

³He detectors were used. Figure 1 shows the core configuration and the position of Am-Be.

For the first several hundred seconds, as shown in Fig.2, the system was kept under steady state. Then the removing of Am-Be started. It takes several minutes but an air duct was used to rapidly terminate the effect of neutron injection to the core from Am-Be. After that, neutron count rate decreased and the measurement terminated after one or several thousand seconds. Another measurement was done under steady state for several thousand seconds in order to take data for Feynman- α method.

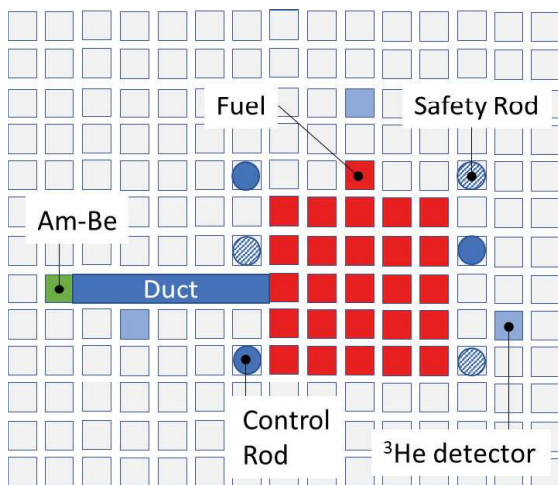

Fig. 1. Configuration of fuels and devices in A-core.

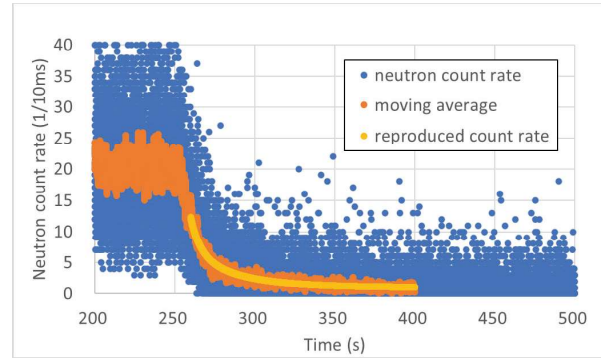

Fig. 2. Neutron count rate data. Blue circle shows neutron counts per 0.01s and orange line shows a profile of averaged neutron counts. Yellow line shows a reproduced count rate.

RESULTS: A preliminarily estimated value obtained by applying the new method to the neutron count rate data was plotted against data by Feynman- α method in Fig. 3, and the range of C/E was between 0.8 and 1.8. The reason for large difference may be that the neutron from slowly moving Am-Be kept the power of the core high for a while after the start of removing and changed the profile of neutron count rate from one without such effect. It is expected that more detailed analysis will make the reason clear.

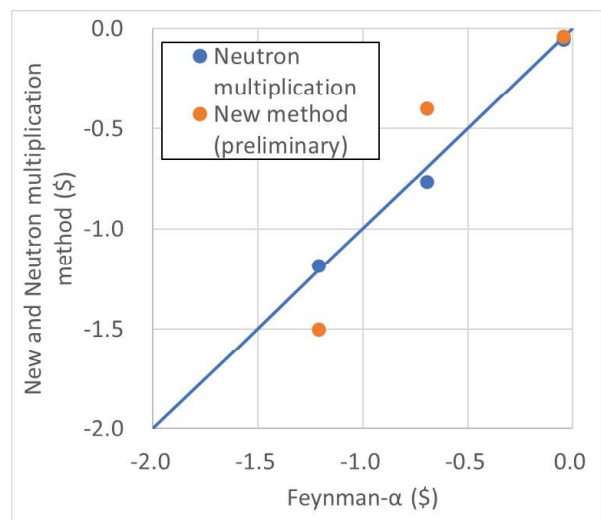

Fig 3. The reactivity estimated by applying new and neutron multiplication methods are plotted against that by Feynman- α method.

REFERENCES:

- [1] Y. Yamane, Proc. 2017 AESJ Spring meeting, 1F04, (2017) [in Japanese].
- [2] Y. Yamane, S. Araki, Y. Kitamura, T. Misawa, Proc. 2019 AESJ Spring meeting, 2J02, (2019) [in Japanese].
- [3] Y. Yamane, J. Nucl. Sci. Technol. <https://doi.org/10.1080/00223131.2020.1736682> (2020).

CO3-10 Measurement of fundamental characteristics of nuclear reactor at KUCA (V)

Y. Kitamura¹, T. Misawa¹, X. Xiao² and Y. Hayashi³

¹*Institute for Integrated Radiation and Nuclear Science, Kyoto University*

²*Department of Fundamental Energy Science, Graduate School of Energy Science, Kyoto University*

³*Toshiba Energy Systems & Solutions Corporation*

INTRODUCTION: We are developing a new signal transmitting/receiving devices. The reactor noise methods can measure the subcriticality through determination of the prompt neutron decay constant. Owing to a great amount of efforts devoted by many researchers, they are now regarded to be one of the most established methods. However, these methods still have one serious problem; the dead time effect that deteriorates the information from the neutron detector and disables the conventional theoretical formula. In 2014, Kitamura and Fukushima hence derived theoretical formulae of two major methods, i.e., Feynman- and Rossi-alpha ones by rigorously considering the dead time effect[1]. However, unfortunately, it was found that their formulae are too complicated to practically apply. Hence, in the present study, another technique for overcoming the dead time effect and its experimental investigation performed at the KUCA are reported.

DEVICES: In the Feynman-alpha method, neutron detection signals from the neutron detector arising within a certain length of the time interval, i.e., the gate width, are counted. By using thus obtained neutron counts, a correlation index Y is calculated to quantify the temporal fluctuations in neutron population in the subcritical multiplying system. The neutron counts with respect to various gate widths are further obtained to calculate the Y values as a function of the gate width, i.e., the Feynman-Y curve. This curve is fitted by the theoretical formula of the Feynman-alpha method to infer the prompt neutron decay constant. However, under high counting-rate conditions, the Y values with respect to shorter gate widths take negative values as shown in Fig. 1. Owing to this fact, the prompt neutron decay constant inferred under such conditions is biased.

In Fig. 2, a couple of neutron detection signals (red and blue dashed lines) overlapping with each other are shown. In the conventional technique, these signals are regarded to be one signal. On the other hand, in the present technique, before counting the neutron detection signals, the overlapped signals (yellow dots) are resolved. To realize such an analysis, in the present technique, a row signal wave-form recording system is introduced.

EXPERIMENTALS: The devices we are developing were examined at the B core of KUCA. The core configuration is given in Fig. 2. The signals from B-10 detector

were read by a pre-amplifier and then fed into the transmitting device. These signals were transmitted to the receiving device through the optical fiber. The time-stamp data were recorded by a PC.

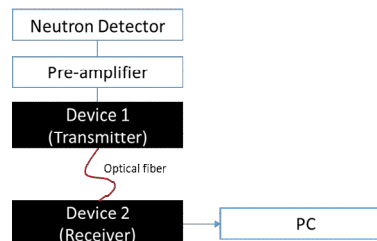
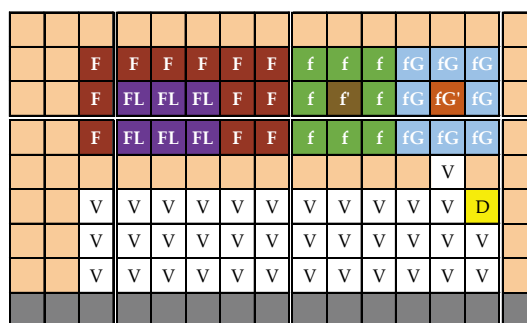

Fig. 1: Example of conventional Feynman-Y curve.



[F]: 2/8"p23EUEU fuel
 [FL]: [F] including LiF
 [f]: 2/8"p22NUEUNU fuel
 [f']: [f] with Cf-252
 [fG]: 1/4"G22NUENNU fuel
 [fG']: [fG] with Cf-252
 [D]: B-10 neutron detector
 [V]: Void sheath

Fig. 2: Core configuration of B-core.

CO3-11 Measurement of Neutronics Characteristics for Th loaded core at KUCA (II)

T. Sano, K. Nakajima¹, J. Hori², Y. Takahashi², H. Yashima², and H. Unesaki²

Atomic Energy Research Institute, Kindai University

¹Graduate School of Science and Engineering, Kindai University

²Institute for Integrated Radiation and Nuclear Science, Kyoto University

INTRODUCTION: In order to perform integral evaluation of the ²³²Th capture cross section, critical experiments with Th loaded various cores at KUCA has been carried out [1]. In those critical cores, the H/²³⁵U nuclide ratio were about 70 to 315 and the ²³²Th/²³⁵U nuclide ratio were about 12.7 to 19.0. In this study, from the viewpoint of expanding critical experimental data, a new experiment was conducted by a Th fuel loaded core with 51 of H/²³⁵U and 19.0 of ²³²Th/²³⁵U ratio at KUCA.

EXPERIMENTS: The new critical core consisted of two type fuel elements. One was Th loaded fuel element, and the other was driver fuel element shown in figure 1. A unit cell of Th loaded fuel element had 2 enriched uranium (EU) plates with 1/16" thickness, 1 Th plate with 1/8" thickness and 1 polyethylene plates with 1/8" thickness. The Th loaded fuel element consisted of 27 unit cells. A unit cell of driver fuel elements consisted of the 1 EU plate and the 2 polyethylene plates. The driver fuel element had of 49 unit cells.

Figure 2 shows the core configuration of the critical experiment. There were the 37 Th loaded fuel elements (F) and the 32 driver fuel elements (D). Table 1 shows the critical data of the core.

RESULTS: First of experiments, the neutronics characteristics of the Th loaded core was measured to check on the parameters are fallen within the KUCA regulations. Table 2 shows the measured neutronics characteristics. The all characteristics are satisfied with the KUCA regulations.

In order to observe an effective multiplication factor (k_{eff}) of the core, the excess reactivity worth was measured by the positive reactor period method. As the seven-times-measured results, the evaluated excess reactivity worth was 0.0826 ± 0.0034 (%dk/k) and the k_{eff} was 1.00083 ± 0.00003 [2]. The calculated k_{eff} by MVP3.0[3] with JELDL-4.0[4] was 1.00488 ± 0.00002 and C/E value was 1.0040 shown in Table 3.

ACKNOWLEDGEMENT:

A part of the present study was supported by CHUBU Electric Power Co., Inc.

REFERENCES:

- [1] T. Sano *et al.*, Proc on PHYSOR2020, Cambridge, UK, Mar.29th – April 2nd, (2020).
- [2] T. Sano *et al.*, Abstract of AESJ Spring meeting, 1I08, (2020).
- [3] Y. Nagaya *et al.*, JAERI1348, JAEA, (2005).
- [4] K. Shibata *et al.*, J. Nucl. Sci. Technol., 39(11), (2002).

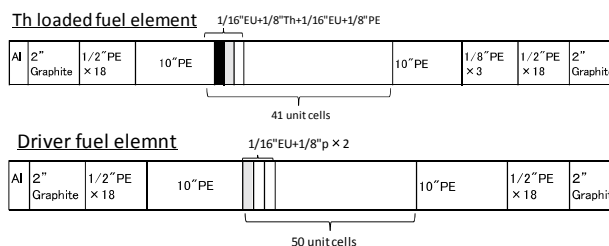
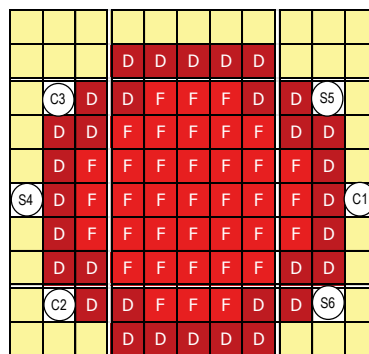

Fig. 1 Configuration of fuel element.



F: Th loaded fuel element, D: Driver Fuel element, C: Control Rod, S: Safety Rod

Fig. 2 Core configuration.

Table 1. Critical data of the Th loaded core.

| Run No. | | 9855-1 |
|---------------------------|------------|---------|
| No. of loaded EU plates | | 4634 |
| No. of loaded Th plates | | 1517 |
| Control Rod position (mm) | C1 | 723.14 |
| | C2 | 1201.14 |
| | C3 | 1201.37 |
| | S4, S5, S6 | 1200 |
| Core temperature (°C) | | 14.9 |

Table 2. Measured neutronics characteristics of the Th loaded core.

| Neutronics Characteristics | Measured (%dk/k) | KUCA Regulation |
|----------------------------|------------------|-----------------------------------|
| Excess reactivity (%dk/k) | 0.082 | < 0.35 (%dk/k) |
| Rod worth (%dk/k) | C1 rod | Max. worth : < 1/3 of total worth |
| | C2 rod | |
| | C3 rod | |
| | Total* | > Excess reactivity + 1 (%dk/k) |
| Center core worth (%k/k) | 2.329 | > 1 (%dk/k) |

*S4, S5 and S6 rod worth are assumed same value as C1, C2 and C3 rods by symmetric geometry.

Table 3. Measured and calculated k_{eff} .

| | |
|------------|------------------------|
| Measured | 1.00083 ± 0.00003 |
| Calculated | 1.00488 ± 0.00002 |
| C/E | 1.0040 ± 0.003 (%) |