

Investigation of the transport properties for saline water in porous materials - Modeling of the permeability coefficient for saline water-

K Sakai¹, N Takatori¹, D Ogura¹, S Wakiya² and M Abuku³

¹ Department of Architecture and Architectural Engineering, Graduate School of Engineering, Kyoto University, Kyoto Daigaku-katsura, Nishikyo-ku, Kyoto, Japan

² National Institutes for Cultural Heritage Nara National Research Institute for Cultural Properties, 2-9-1, Nijo-cho, Nara-shi, Japan

³ Faculty of Architecture, Kindai University, 3-4-1, Kowakae, Higashi-Osaka-shi, Osaka, Japan

Corresponding email: takatori.nobumitsu@archi.kyoto-u.ac.jp

Abstract. Salt weathering is a major concern for cultural heritages such as ruins and tombs, and desalination by poulticing is an interesting potential method to efficiently remove contaminating salt. Predicting the degree of achievable desalination is very important. However, many existing models used to consider saline water transport in porous materials have been developed based on the theory of pure water. To understand saline water flow in porous materials, we determined the saline water permeability of a tuff stone by the falling-head method. We found that the permeability of the tuff stone was affected by factors other than the density and dynamic viscosity of the saline water.

1. Introduction

Salt weathering is a major concern for cultural heritages such as ruins and tombs [1]. Since they cannot be preserved separately from the ground, desalination by poulticing [2] is an interesting potential method to efficiently remove contaminating salt. Predicting the degree of achievable desalination is very important. However, many existing models used to consider saline water transport in porous materials have been developed based on the theory of pure water [3]. They have not taken into account the salt sieving effect, osmosis, and other key effects. The presence of salt also changes both transport coefficients and driving forces of saline water. Therefore, it is unlikely that the existing models can be suitably applied to all desalination conditions.

We aim to develop a new numerical analysis model to quantitatively calculate the amount of desalination. As the first step, we measure the permeation of saline water through porous materials to understand the dependence of permeation on salt concentration.

2. Experimental Method

In this study, we measured the permeation of saline water by the falling-head method [4], in which the driving force of permeation is only gravity.



2.1. Falling-head method

Flow of saline water in the porous material under the effect of gravity was measured in accordance with the Japanese Industrial Standard (JIS A 1218) [5].

2.1.1. Equipment. The equipment used for the falling-head test is shown in Figure 1. A porous tuff stone extracted in Japan was used as the test specimen. A side of the specimen was sealed using paraffin and a waterproof tape.

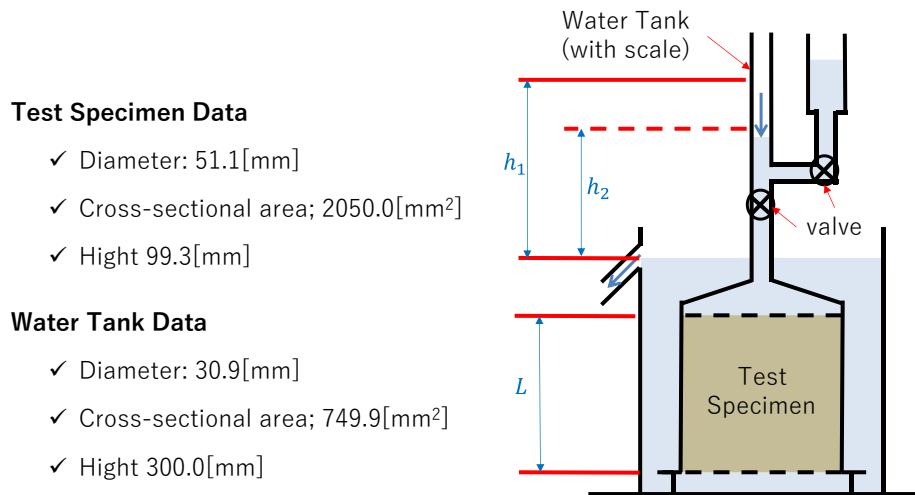

Figure 1. Schematic of the falling-head test.

2.1.2. Procedure. Amount of solution flowing through the specimen was measured using the difference in the water surface position of the tank. The position of the water surface was recorded at regular intervals, and time taken for the solution volume to reach about 75cm³ was measured. To ensure the accuracy of the measurements, the experiment was carried out at least eight times for each salt concentration.

2.1.3. Permeability. Permeability of the sample k_T [m/s] at water temperature T [°C] in the falling-head method is expressed as [5]

$$k_T = 2.303 \times \frac{a \times L}{A \times \Delta t} \times \log_{10} \left(\frac{h_1}{h_2} \right) \times \frac{1}{1000} \quad (1)$$

where a is the cross-sectional area of the standpipe [mm²], L is the length of the test sample [mm], A is the cross-sectional area of the test sample [mm²], Δt is measurement time [s], and h_1 and h_2 are water levels [mm] at the start and end of time interval Δt , respectively.

2.2. Measurement conditions

The experiments were conducted at 23°C. The same porous specimen was used throughout all experiments. Sodium chloride was used as the solute, and the solute were prepared to be 75%, 50%, 25%, 10%, and 0% of the solubility. The experiments were conducted in descending order.

3. Prediction Model Based on the Hagen–Poiseuille Equation

Using the Hagen–Poiseuille equation [3], the permeability of the sample is given as

$$D_{sw} = D_w \frac{\rho_{sw} \eta_w}{\rho_w \eta_{sw}} \quad (2)$$

D_w and D_{sw} are pure and saline water permeabilities [m/s], respectively, ρ_w and ρ_{sw} are pure water and saline water densities [kg/m³], respectively, and η_w and η_{sw} are dynamic viscosities [Pa s] of pure and saline water, respectively.

4. Results and Discussion

Figure 2 shows the measurement results of the falling-head test and predicted results of saline water based on the permeation of saline water (at 75%) [6]. Although permeability gradually varied with time, we showed average values when it stabilized. The error bars represent the range of measurements taken as an average.

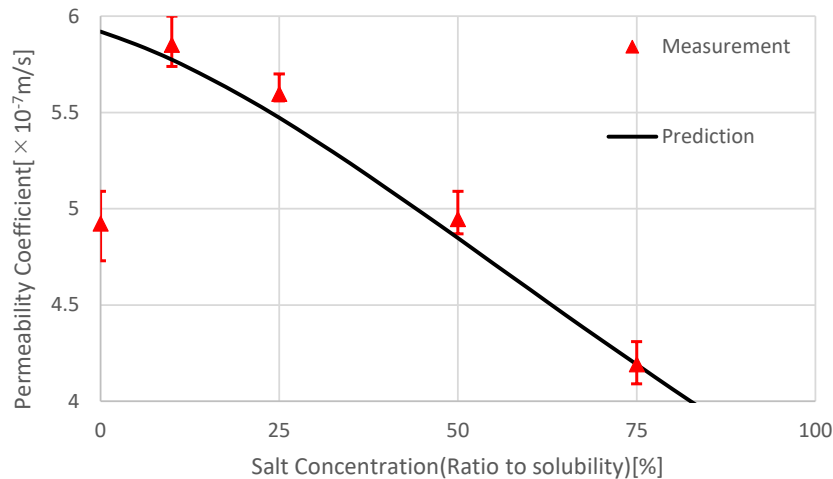

Figure 2. Prediction and experimental results.

Unlike the predicted results, the experimental results are affected by factors other than the density and dynamic viscosity of saline water. It is known that clay materials have a surface charge, and solutions adsorbed on its surface forms an electric double layer. And also, an electric double layer affects the permeability of solution and varies with the salt concentration of the solution [7]. The tuff stone used in experiments related to this study could also be affected by surface charge.

5. Conclusion

We measured the permeation of saline water by the falling-head test using a tuff stone. The results showed that the permeability of the test sample was not determined only by the density and dynamic viscosity of saline water. In our future research, we would like to verify this result by focusing on the effect of the electric charge inside the porous material.

Acknowledgement

This work was supported by JSPS KAKENHI Grant Number JP20K22445 and JP18H01596.

References

- [1] Goudie A S and Viles H A 1997 *Salt weathering hazards* Wiley
- [2] Pel L, Sawdy A and Voronina V 2010 Physical principles and efficiency of salt extraction by poulticing *Journal of Cultural Heritage* **11** 59–67
- [3] Niocali A 2008 Modelling and numerical simulation of salt transport and phase transitions in unsaturated porous building materials *Ph.D. thesis*
- [4] William A and Horton R 2004 *Soil physics -6th edition-* John Wiley & Sons
- [5] Japanese Industrial Standard 2020 Test methods for permeability of saturated soils *JIS A 1218*
- [6] Kestin J, Khalifa H E and Correia R J 1981 Tables of the dynamic and kinematic viscosity of aqueous NaCl solutions in the temperature range 20-150 C and the pressure range 0.1-35MPa *Journal of Physical and Chemical Reference Data* **10** 71
- [7] Jo H Y, Katsumi T, Benson C H and Edil T B 2001 Hydraulic conductivity and swelling of nonprehydrated GCLs permeated with single-species salt solutions *Journal of Geotechnical and Geoenvironmental Engineering* **127** Issue 7