

Effect of Free Surface on the Yielding Resistance of Materials.

By

Toshio NISHIHARA and Shūji TAIRA

(Received September, 1949)

Introduction

As for the stress measurement of specimens applied a load within the yield point, many experimental results are found. In the case of plastically deformed metals, however, experimental data with regard to measured stress is scarcely found. The present paper relates mainly to the stress distribution in test pieces of various sorts of metals subjected to tensile or compressive axial load and deformed beyond the yield point.

In part I, the experimental results obtained are exhibited from which we find the fact that when specimens are deformed plastically even under an axial load the stress existing in the cross section loses its uniformity in such a manner that the stress near the surface is lower as compared with the one existing in the inner portion. The experiments for measuring stress are performed mainly by means of X-ray. It is considered rationally to be caused by the difference of plastic strain in the inner portion to that near the surface, as was confirmed by a series of experimental results. The phenomenon we named "the surface effect".

In Part II, considering the metals as an aggregation of minute crystal grains and taking into account the mutual restricting influence of grains as the factor affecting the yielding resistance, analytical treatment will be exhibited concerning the yielding resistance. It will be seen that the theoretical view is in good agreement with the experimental results.

Part I. Experimental survey of the stress in the specimens deformed plastically.

1) X-ray stress measurement.

The local stress acting on the surface of metallic substance is measured most

conveniently by means of X-ray. As to the X-ray stress measurement, a brief review will be made. The principle of the X-ray stress measurement is to utilize the diffraction of X-ray. The strain measured by this method is that of atomic lattice and so is perfectly elastic. Applying the X-ray stress measurement for the case beyond the yield point, the strain obtained is elastic one itself, separated from plastic strain, while nominal strain is the sum of both kinds of strain.

As to the theoretical view of the X-ray stress measurement, it has been reported in another paper by authors¹⁾. Therefore, it will be here described as briefly as may be necessary for the explanation of the experimental results exhibited later on.

We utilized the four methods of the X-ray stress measurement in all in expectation of higher precision of measured stress. The first is the method by F. Weber and H. Möller, where the stress is obtained by measuring the change of spacing nearly parallel to the surface of specimens. The others are R. Glocker's methods, where both patterns obtained from perpendicular as well as oblique incident X-ray beam are utilized. Therefore, the stress is determined by the change of both spacing, the one parallel and the another oblique to the surface of specimens. The stress obtained by the former method is denoted as σ_{\perp} and the one by the latter as $\sigma_{\perp+}, \sigma_{\perp-}$ and σ_{+-} . From the stand point of measuring stress, the latter is more suited in the present study, because utilizing the former we should fail to distinguish the existence of stress from the expansion or contraction of metals.

2) Stress acting on the surface of yielding specimens.

Round and rectangular bars of some sort of metals was subjected to an axial tensile or compressive load beyond the yield point and at each step of the sequence of deformation the surface stress was measured by means of X-ray. A few of the obtained results will be exhibited.

2-1) Tension test

a) Mild steel²⁾

Annealed round bars of 11 mm diameter and 70 mm in length (0.07% C steel) were stretched beyond the yield point and to each of them was given a permanent set of 6.4, 10 and 16.3% respectively. Then, the stresses acting on the surface were measured by means of X-ray by way of decreasing the applied load. Fig. 1 illustrates the stress-strain diagram of the specimen and shows the condition under which the stresses were measured. The result is shown in Fig. 2, in which the

1) T. Nishihara, S. Taira, Mem. Coll. Engr. Kyoto Imp. Univ. XI 6, (1947), p. 315.

2) T. Nishihara, S. Taira, Trans. Soc. Mech. Engr. Japan, Vol. 13, No. 45 (1947), p. 135.

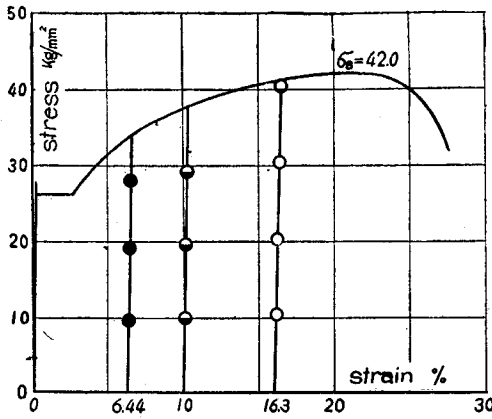

Fig. 1

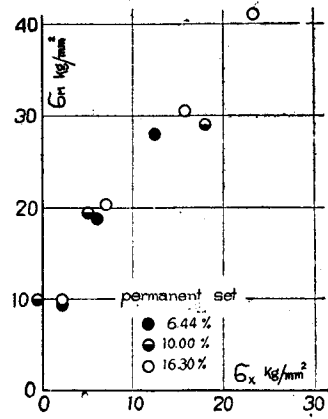

Fig. 2

measured stress σ_X is found to be lower by 10~15 kg/mm² than the corresponding mechanical stress σ_M calculated from the applied load. Hence, a number of experiments were carried out for the purpose of making sure the tendency of the relation of σ_X to σ_M . In case of the any performed experiments, σ_X is always obtained lower than σ_M , while, as far as σ_M lies within the yield point, σ_X is obtained equally to the corresponding mechanical stress σ_M . Moreover, when the load is removed, compressive stress is found to remain on the surface, whose absolute value is approximately equal to the difference ($\sigma_M - \sigma_X$). Figs. 3 a

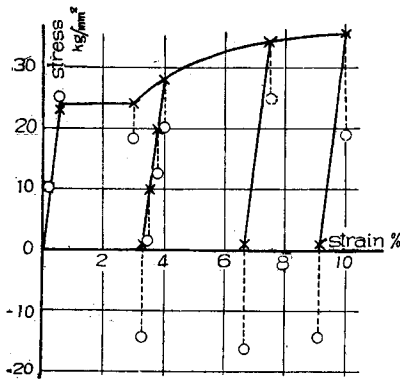

Fig. 3a

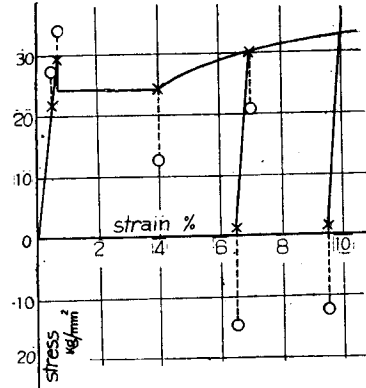

Fig. 3b

and b show some of obtained results. Surveying the results, they seem to comply with those of F. Bollenrath and others.³⁾

3) F. Bollenrath, V. Hauk u. E. Osswald, V. D. I. Bd. 83, Nr. 5 (1939) S. 129.
 F. Bollenrath u. E. Osswald, V. D. I, Bd. 84, Nr. 30, (1940) S. 539.

b) Aluminium ⁴⁾

As an example of light metals, annealed aluminium specimens of 11 mm in diameter and 50 mm in length were experimented upon in the same manner as above. Fig. 4 shows the stress-strain diagram and Figs. 5a and b some of results obtained. The tendency of the relation between σ_X and σ_M is the same as in the case of mild steel.

In this place, we tested an aluminium specimen of $2 \times 10 \text{ mm}^2$ in section and 160 mm in length, cut from a rolled plate in market and being given no subsequent heat treatment. It gave the X-ray pattern of continuous ring. The surface stress measured is exhibited in Fig. 6. We see σ_X coincide with σ_M in the range of measuring error and residual stress is not found.

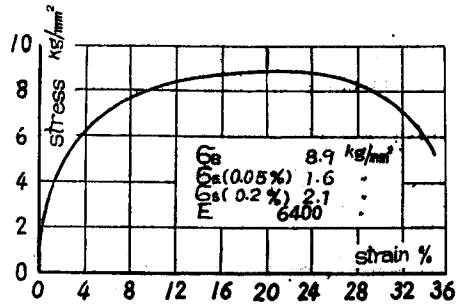

Fig. 4

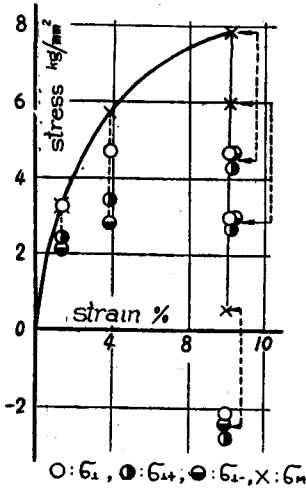

Fig. 5a

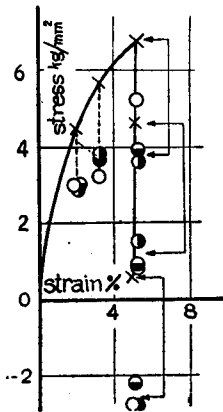

Fig. 5b

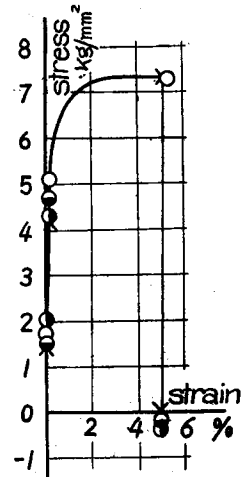

Fig. 6

2-2) Compression test

It may be considered a matter of course that there must be no inherent difference between the plastic deformation by tension and by compression. The same relation of σ_X and σ_M as in the case of tension ought to be expected. With such a view, a number of compression tests were carried out.

4) T. Nishihara, S. Taira, Trans. Soc. Mech. Engr. Japan, Vol. 14, No. 47 (1948). p. 1.

a) Mild Steel

Round bars of annealed mild steel, the same material as used in tension test, of 12 mm diameter and 24 mm in length were used as specimens. Fig. 7 is an example of obtained results, where only the residual stress was measured. Tensile residual stress is obviously found on the surface of specimen compressed plastically. Hence, it may be sure that in the case of plastic compression a tensile stress remains on the surface of specimen and, quite the contrary, in the case of plastic tension compressive stress exists and that the absolute value of residual stress is equal in both cases under equal load.

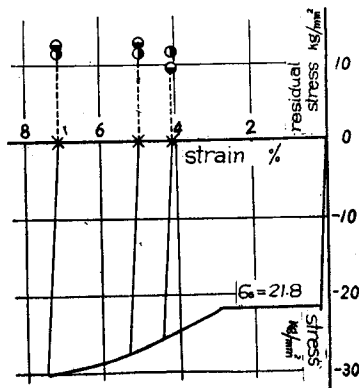

Fig. 7

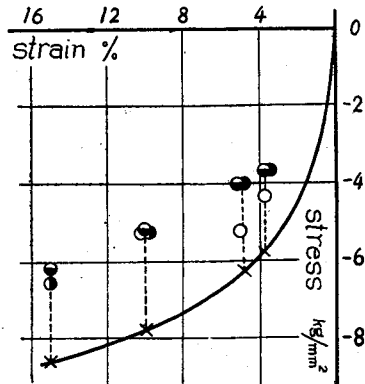

Fig. 8

b) Aluminium

Fig. 8 shows, as an example, the experimental result obtained from the compression test of pure aluminium round bar, 11 mm diameter and 22 mm in length and the same material as used in tension test. The relation between the measured stress and the mechanical stress is the same as in the case of mild steel.

c) Hard steel

Annealed 0.55% C steel round bar was compressed plastically and the surface stress was measured. The result obtained is as shown in Fig. 9, in which we see that the residual tensile stress exists in this case also, even though the value is rather smaller compared to that of mild steel.

Considering the above results, we can conclude that, original structure of crystal being

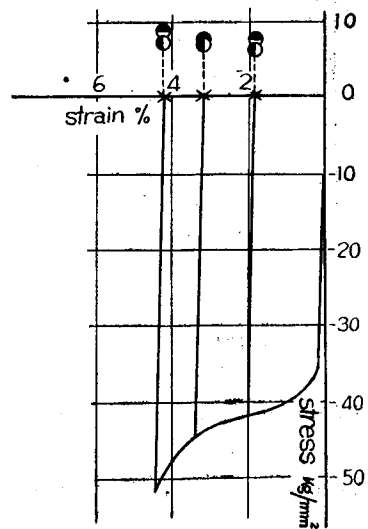

Fig. 9

normal, σ_x is always obtained smaller than σ_M when the latter is beyond the yield point and, when the load is removed, a residual stress is found to remain on the surface, whose absolute value is equal to the difference of the magnitude of σ_M to that of σ_x under the load and its sign is contrary to that of applied load. To analyse the phenomenon, the following assumption was adopted concerning the plastic deformation of metals. When the specimens are once deformed beyond the yield point, the plastic strain tends to be distributed not uniformly, i. e. rather larger near the free surface than in the core portion. In other words, under loaded condition higher elastic stress is roused in the core than near the surface and, when the load is removed, residual stresses remain due to the difference of the amount of plastic strain between inner and outer portion.

3) Residual stress distribution.

To confirm the propriety of the above assumption, we investigated the distribution of the residual stress existing in the cross section of plastically deformed specimens.

3-1) Experiment by means of X-ray stress measurement.

Test pieces elongated or compressed plastically are corroded by chemical agents, solution of nitric acid for steel and that of sodium hydroxide for aluminium, from the surface in sequence and at several steps of corrosion the stress on the corroded surface was measured.

a) Mild steel ²⁾

Fig. 10 shows the obtained distribution of residual stress existing in the same tensile specimen of mild steel as those used in tension test where the specimen has been given a permanent set of 6%. Fig. 11 is the result of compressed specimen same as those used in compression

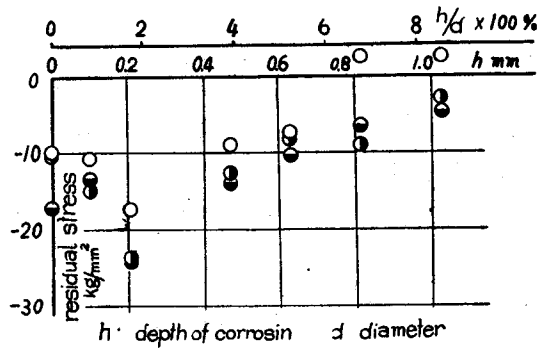

Fig. 10

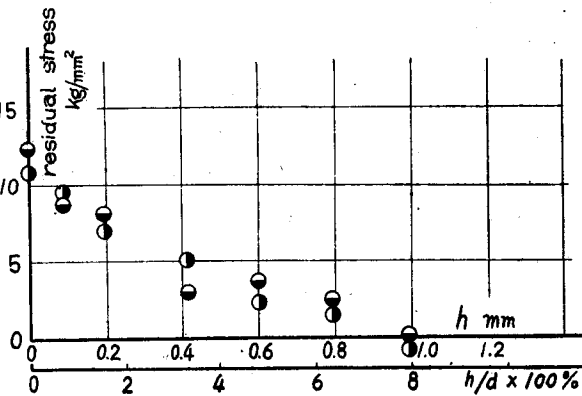

Fig. 11

test, under a permanent set of 5%. In both cases, near the surface, there exists residual stress of opposite sign to the applied load, reducing its magnitude with the increase of the depth of corrosion. In the inner portion, therefore, a stress of the same sign as the applied load is necessarily considered to exist. Fig. 12

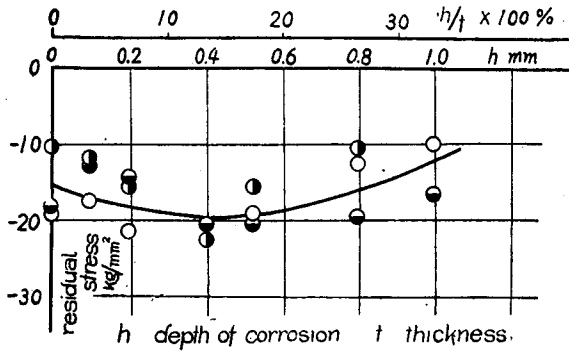

Fig. 12

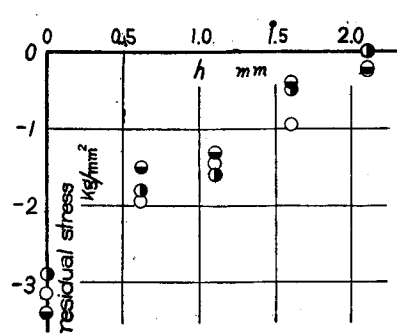

Fig. 13

illustrates the result obtained from the experiment on a mild steel plate, $3 \times 10 \text{ mm}^2$ in section and 220 mm in length, under 5% elongation. In this case, however, it is remarked that the tendency of the reduction of measured stress in the inner portion is not the same as was seen in the case of round bar. It is because of the fact that, as the plate used was thin, the portion where compressive stress exists is rather larger as compared with the full section of the specimen and, as the result of corrosion, the plate bends itself to the corroded side and a bending stress is, therefore, added to the inherent distribution of residual stress. Assuming the distribution of the residual stress in the section to be cosine curve and taking into account of additional bending stress caused by corrosion, the resultant value of stress acting on the corroded surface was calculated and shown by the full line in figure.

b) Aluminium⁴⁾

Fig. 13 and Fig. 14 show the residual stress distribution in the cross section of plastically deformed tensile and compressive specimens of aluminium, same as those used in tension or compression test. The former has been given a permanent set of 20% and the latter of 15%. The residual stress distribution is the same in both cases except the opposition of the sign, as was seen in the case of mild steel.

c) Hard steel

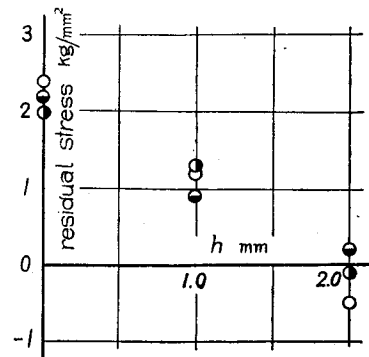

Fig. 14

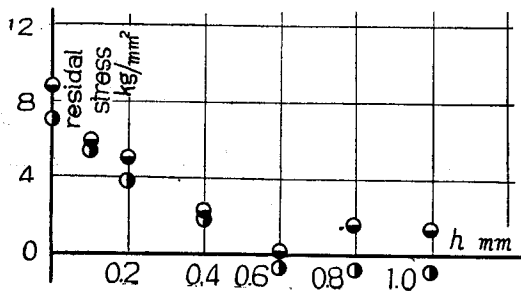

Fig. 15

Fig. 15 shows the residual stress distribution in a compressed specimen of hard steel under a permanent set of 4.12 %. The portion, where the residual stress changes its sign, lies rather nearer the surface and the magnitude of the stress is smaller as compared with the case of mild steel.

3-2) Determination of residual stress by corrosive method.⁵⁾

Hitherto, the residual stress was observed only by means of X-ray. For the purpose of giving corroborative evidence of existence and tendency of residual stress, experimental results by any other methods are necessarily multiplied. Suggested from the fact that an elongated thin plate bends itself by removing laminar portion from the surface on one side we intended contrariwise to observe the distribution of residual stress by corrosion method. The setting for the experiment is shown in Fig. 16. In the figure, (1) is specimen, (3) reservoir of corrosive agent (20 % solution of nitric acid) made of flexible material and (2) measuring bars.

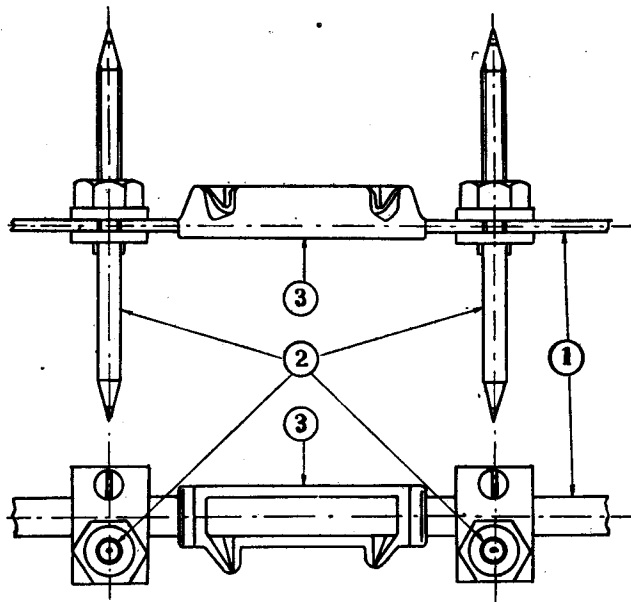

Fig. 16

The gauge lengths, the distances between both side of the ends of measuring bars, change as corrosion proceed. The radius of curvature of the plate with regard to the depth of corrosion was measured and hence the residual stress existed in the corroded layer was calculated. As an example, Fig. 17 illustrates the obtained distribution of stress remaining in the section of 2.56 % elongated

5) T. Nishihara, S. Taira, Trans. Soc. Mech. Engr. Japan, Vol. 14, No. 49 (1948), p. 1.

mild steel plate of 3×10 mm² in section. Fig. 18 is the bent specimen by corrosion. The distribution of residual stress thus obtained is seen to agree very well with that determined by X-ray method.

4) Survey of the experimental results.

In 1940, W. A. Wood and S. L. Smith⁶⁾ reported the results of their experiments

concerning the change of spacing of atomic planes with the increase of axial extension of pure iron, they found the spacing of atomic planes, nearly parallel to the surface of specimens, to expand as the result of extension and concluded that the metals expand by cold work. According to the author's view, the results are of measurement of σ_{\perp} and it seems

not to be rational to explain the results by expansion only. In this place, the opinion of F. Bollenrath and E. Osswald³⁾ with regard to the relation of σ_M and σ_X based on their experimental results seems of importance to us.

From the results of a number of experiments of yielding specimens under axial load, we ascertained that the stress of surface layer does not coincide with the mechanical stress and that a stress remains in the section when the applied load is removed.

The metals are generally treated as isotropic and homogeneous in the calculation of the strength of machine parts. In fact, however, they are an aggregation of crystal grains, each of which is really anisotropic. When metals are deformed plastically, each crystal, which composes metals, deforms by slipping on the slip planes and along slip directions, which are both inherent crystallographically with respect to the sort of metals. When a single crystal specimen is elongated, the deformation is not constrained from other grains and the force necessary for a

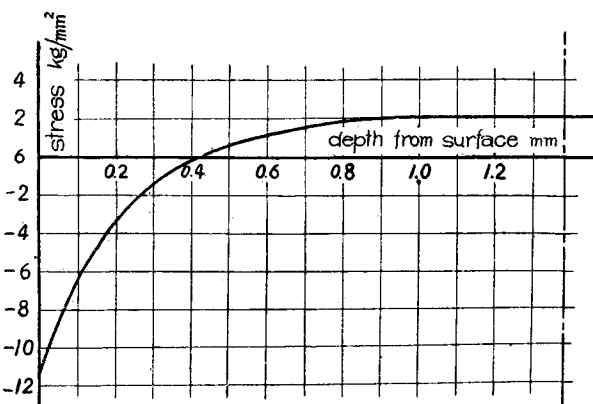

Fig. 17

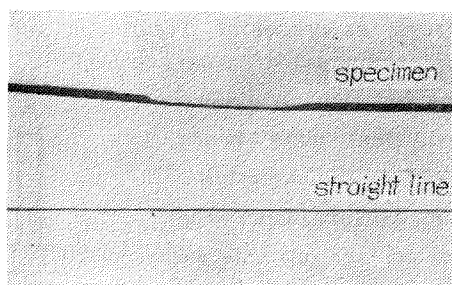

Fig. 18

6) W. A. Wood & S. L. Smith, Nature, 146 (1940) p. 400.

Proc. Roy. Soc. (London) A. 178, (1941) p. 93.

deformation may be rather small. Considering the plastic deformation of polycrystalline metals, however, we must take into account the following fact. As the orientation is different from grain to grain in general, each grain tends to slip in different directions and the neighbouring grains exert a restricting influence on the amount and kind of slip that may occur within each grain. The force needed to produce a given deformation should be rather larger compared with the case of single crystals. The crystals on the surface are comparatively free to deform, that is to say, one side of them is free from the restriction of the neighbouring grains. On the contrary the grains in the core are surrounded by many crystals and are more difficult to deform plastically than those near the surface on account of restricting influence of neighbouring grains. These facts are here considered to be the cause of the phenomenon above mentioned. It seems to support the authors' view that in a material of which the crystal structure is broken down by cold work as rolling the phenomenon is not found. The phenomenon we name "the surface effect" of yielding metals. Introducing this idea the experimental results seem to be explained without discrepancy so far as we have experienced.

Part II. Analytical representation of yielding resistance.

1) Fundamental conception of the yielding resistance.

Based upon the consideration given at the end of Part I, we shall proceed to try to deal with the yielding resistance theoretically. In this place, the practical figure of mutual restriction must necessarily be known. In practice, however, it does not lend itself to an exact analysis by means of principle of mechanism, even though its view is supported by many and varied observations.⁷⁾ The present analysis of yielding resistance will be carried out using some assumption with regard to the manner of mutual restriction.

Assuming the yielding resistance of any crystal, building polycrystalline specimens, to be affected by mutual restriction with other grains, it may be easily considered to depend on the position where the crystal grain lies. Considering many cross section in a uniform bar, the grains existing in the corresponding position must have the same magnitude of yielding resistance. Binding these grains, a file of crystals may be given. That is to say, all the grains involved in any crystal file are of equal magnitude of resistance. Taking any cross-section, we can suppose a number of sections of crystal files, of which total number is

7) H. Unkel, *Z. f. Metall-kde.* (1937) S. 413.

R. F. Miller, *Proc. Amer. Inst. Met. Engr.* Vol. 11 (1934) p. 135/45.

equal to that of grains contained in the section and the yielding resistance is different from each other. We may proceed to formulize the yielding resistance staning on the basis of the such conception of crystal files.

As to the law governing the increase of resistance caused by the restriction of neighbouring grains, two sorts of assumptions were used. The one we name the series representation and the other the representation by exponential function with respect to the mathematical view.

2) The series representation.

2-1) Law of mutual restriction.

From such view of crystal files as above, we may consider for any file to have inherent resistance r_0 added its increment r' caused by the mutual restriction with other crystal files. We assume at first, directly neighboring files exert the increase of resistance by the amount $r_0 \frac{c}{k}$, the files containing one between them by $r_0 \frac{c}{k^2}$, and so forth $r_0 \frac{c}{k^3}$, $r_0 \frac{c}{k^4}$, , where c is mutual restriction constant and $\frac{1}{k^n}$ is diminution constant of restriction on account of the remotion of both files.

2-2) Distribution of yielding resistance.

a) Rectangular bar.

Microphotographs of metals show the crystal grains are irregular in shape and size and not easy to be treated in simple ways. We assume at just the grains lie regularly as seen in Fig. 19. Ranking crystal files along a line, a

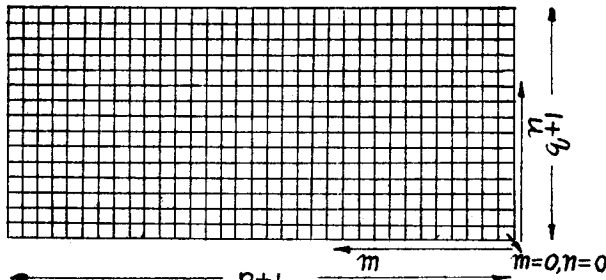

Fig. 19

crystal lamina is obtained and any rectangular bar is built by heaping laminas in sequence. In a cross section of uniform bar we consider sections of crystal files of δ in dimension to marshal by $(p+1)$ in breadth and $(q+1)$ in thickness. Any section of file is enumerated by m

breadthwise and by n thicknesswise, taking the origin at the point of one occupying the corner ($m=0, n=0$) of the cross section.

a-i) Crystal files in crystal lamina.

As an extreme case, the yielding resistance r_m of any crystal file existing in a crystal lamina built of $(p+1)$ files is calculated as follows. As the yielding resis-

tance of file is sum of inherent resistance r_0 and increment of resistance caused by mutual restriction from all the other files in lamina;

$$\begin{aligned} r_m &= r_0 + r_0 c \left(\sum_{i=1}^m \frac{1}{k^i} + \sum_{i=1}^{p-m} \frac{1}{k^i} \right) \\ &= r_0 \left\{ 1 + ch \left(2 - \frac{h^{p-m} + k^p}{k^m} \right) \right\}, \end{aligned} \quad (2-1)$$

where

$$\begin{aligned} h &= \frac{1}{k-1} \\ r_{m=0} &= r_0 \left\{ 1 + ch \left(1 - \frac{1}{k^p} \right) \right\} \\ r_{m=\frac{p}{2}} &= r_0 \left\{ 1 + 2ch \left(1 - \frac{1}{k^{p/2}} \right) \right\} \end{aligned}$$

When p is large, $r_{m=0} < r_{m=\frac{p}{2}}$ as $1/k^p = 1/k^{p/2} \cong 0$, that is, in a crystal lamina, the resistance of the end file is smaller than that of the file remote from the end. Denoting the resistance of lamina by R_m , which is total sum of resistance of each crystal file involved in the lamina, it follows;

$$\begin{aligned} R_m &= \sum_{m=0}^p r_m \\ &= r_0 \left[(p+1) + 2ch \left\{ (p+1) - h \left(k - \frac{1}{k^p} \right) \right\} \right] \end{aligned} \quad (2-2)$$

The mean value r_{mean} of resistance of file in lamina is obtained ;

$$\begin{aligned} r_{mean} &= \frac{R_m}{p+1} \\ &= r_0 \left[1 - 2ch \left\{ 1 - \frac{h}{p+1} \left(k - \frac{1}{k^p} \right) \right\} \right] \end{aligned} \quad (2-3)$$

a-ii) Crystal file in a uniform bar.

As the resistance r_{mn} of crystal file composing a rectangular bar is affected by all the other files, it is represented as follows ;

$$r_{mn} = r_m + r_0 c I J ,$$

where

$$\begin{aligned} I &= \sum_{i=1}^{p-m+1} \frac{1}{k^i} + \sum_{i=2}^{m+1} \frac{1}{k^i} = h \left(1 - \frac{1}{k^{p-m+1}} \right) + h \frac{1}{k} \left(1 - \frac{1}{k^m} \right) \\ J &= \sum_{j=0}^{n-1} \frac{1}{k^j} + \sum_{j=0}^{q-n-1} \frac{1}{k^j} = hk \left(1 - \frac{1}{k^n} \right) + hk \left(1 - \frac{1}{k^{q-n}} \right) \end{aligned}$$

Substituting (2-1),

$$r_{mn} = r_0 [1 + ch^2 \{4k - (p+1)(M+N) + MN\}], \quad (2-4)$$

where $M = \frac{k^{p-m} + k^m}{k^p}$ and $N = \frac{k^{q-n} + k^n}{k^q}$,

The resistance R_{mn} of the bar is, summing up that of each file,

$$\begin{aligned} R_{mn} &= \sum_{m=0}^p \sum_{n=0}^q r_{mn} \\ &= r_0 \left[(p+1)(q+1) + 4ch^2 \left\{ k(p+1)(q+1) \right. \right. \\ &\quad \left. \left. - \frac{k+1}{2} h \left((q+1) \left(k - \frac{1}{k^p} \right) + (p+1) \left(k - \frac{1}{k^q} \right) \right) \right. \right. \\ &\quad \left. \left. + h \left(k - \frac{1}{k^p} \right) \cdot h \left(k - \frac{1}{k^q} \right) \right\} \right] \quad (2-5) \end{aligned}$$

Hence, mean resistance r_{mean} of crystal files in the bar is obtained by

$$\begin{aligned} r_{mean} &= \frac{R_{mn}}{(p+1)(q+1)} \\ &= r_0 \left[1 + 4ch^2 \left\{ k - \frac{k+1}{2} (P+Q) + PQ \right\} \right], \quad (2-5) \end{aligned}$$

where $P = \frac{k}{p+1} \left(k - \frac{1}{k^p} \right)$, $Q = \frac{k}{q+1} \left(k - \frac{1}{k^q} \right)$,

Using (2-5), the yielding resistance of peculiar points in the cross section, such as the corner ($m=0, n=0$), the center ($m=\frac{p}{2}, n=0$) and ($m=0, n=\frac{q}{2}$) of both sides and center ($m=\frac{p}{2}, n=\frac{q}{2}$) of the cross section are represented as follows;

$$r_{m=0, n=0} = r_0 \left[1 + ch^2 \left\{ (2k-1) - k \left(\frac{1}{k^p} + \frac{1}{k^q} \right) + \frac{1}{k^{p+q}} \right\} \right] \quad (2-7)$$

$$r_{m=\frac{p}{2}, n=0} = r_0 \left[1 + ch^2 \left\{ 4k - (k+1) \left(1 + \frac{2}{k^{p/2}} + \frac{1}{k^q} \right) + \frac{2}{k^{p/2}} \left(1 + \frac{1}{k^q} \right) \right\} \right] \quad (2-8)$$

$$r_{m=0, n=\frac{q}{2}} = r_0 \left[1 + ch^2 \left\{ 4k - (k+1) \left(1 + \frac{1}{k^p} + \frac{2}{k^{q/2}} \right) + \frac{2}{k^{q/2}} \left(1 + \frac{1}{k^p} \right) \right\} \right] \quad (2-9)$$

$$r_{m=\frac{p}{2}, n=\frac{q}{2}} = r_0 \left[1 + 4ch^2 \left\{ k - \frac{k+1}{2} \left(\frac{1}{k^{p/2}} + \frac{1}{k^{q/2}} \right) + \frac{1}{k^{\frac{p+q}{2}}} \right\} \right] \quad (2-10)$$

From (2-4)~(2-10), the distribution of resistance in a cross section of rectangular bar of any dimension can be calculated.

b) Circular bar.

In general, the radius of round bar may be considered very large as compared with the dimension of crystal grains as far as the radius is not extremely small. In such case, the resistance of crystal file within a round bar can be calculated utilizing the formula for rectangular bar. That is, the file on any diameter of circular section can be reasonably identified with the one lying on the corresponding position of a line, binding both middle points of opposite side of rectangular bar, whose sectional area is equal to that of round bar and the breadth is the same length with the diameter of the round bar, as is shown in Fig. 20.

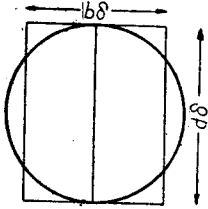

Fig. 20

Denoting the diameter of round bar as $d\delta$, the section of rectangular bar as $b\delta \times d\delta$, we obtain :

$$\frac{\pi d^2}{4} \delta^2 = b\delta \times d\delta \quad \therefore b \approx 0.8d$$

Numerating the position of the crystal file on any diameter by n , taking $n=0$ on the surface, the resistance r_n can be obtained from (2-4) as follows:

$$r_n = r_0 \left[1 + ch^2 \left\{ 4k - (k+1) \left(\frac{2}{k^{b/2}} + N \right) + \frac{2}{k^{b/2}} N \right\} \right], \quad (2-11)$$

where
$$N = \frac{k^{d-n} + k^n}{k^d}$$

Hence, the resistance R_n of round bar is given by

$$\begin{aligned} R_n &= \pi(d-1)r_{n=0} + \pi(d-3)r_{n=1} + \pi(d-5)r_{n=2} + \dots + \pi \cdot r_{n=\frac{d}{2}-1} \\ &= \pi r_0 \left[1 + ch^2 \left\{ 4k - (k+1) \frac{2}{k^{b/2}} \right\} \right] \frac{d^2}{4} \\ &\quad + \pi r_0 ch^2 \left\{ \frac{2}{k^{b/2}} - (k+1) \right\} \left\{ (d-1)h \left(k - \frac{1}{k^d} \right) + \frac{1}{k^{d/2}} - 2h^2 k \left(1 - \frac{1}{k^d} \right) \right\} \end{aligned} \quad (2-12)$$

Hence, the mean resistance r_{mean} is given as follows :

$$\begin{aligned} r_{mean} &= R_n / \frac{\pi d^2}{4} \\ &= r_0 \left[1 + 4ch^2 \left\{ k - \frac{k+1}{2} \left(\frac{1}{k^{b/2}} + D \right) + \frac{1}{k^{b/2}} D \right\} \right], \end{aligned} \quad (2-13)$$

where
$$D = \frac{2h}{d} \left[\frac{d-1}{d} \left(k - \frac{1}{k^d} \right) + \frac{1}{dh} \frac{1}{k^{d/2}} - \frac{2(h+1)}{d} \left(1 - \frac{1}{k^d} \right) \right]$$

2-3) The meaning and determination of the constants.

r_0 means the inherent resistance of each crystal file. So far as a single crystal is concerned, r_0 must be determined according to the relative direction of crystal axis to that of applied load. In this place, from the fundamental idea of crystal file, the crystals involved in it can take random orientation and so they exert restrictions upon each other. Therefore, the yielding resistance r_0 of crystal file is not the same as that of single crystal but implies the mean value of resistance of single crystals of all probable orientations, added increment of resistance caused by the mutual restricting influence, in which the influence of grain boundary should be involved. Because the crystals are hardened as the result of slip, as a matter of course, r_0 is considered to be a function of degree of slip. From the fundamental conception concerning the cause of the surface effect, that is, the cause of the phenomenon consisting in the existence of the slight difference of plastic deformation between inner and outer portion, it seems to be inconsistent to put r_0 as constant value in all files composing the bar. Taking account of the fact that the difference itself is very small and that, as is obviously known from the stress-strain relation, the increment of resistance in accordance with the increase of deformation is comparatively small, so far as the deformation is rather large, such assumption may be admitted.

r_{mean} implies the actual mechanical stress itself, under a definite value of permanent set. From the formula (2-6), it is found to be a matter of interest that, comparing the value of r_{mean} of same material, the larger p and q are, the higher the value of r_{mean} is. Observations in support of this fact are seen in many treatises on deformation of metals and will be shown by examples later on.

The stress measured by means of X-ray is elastic one on the surface and so is the yielding resistance itself. The residual stress existing in a plastically deformed bar after removal of applied load is here represented by the difference of r_{mean} to the resistance value r_{mn} of any portion in the cross section.

c is restriction constant and $\frac{1}{k^n}$ diminution constant, as was mentioned above. The distribution of resistance in the cross section can be determined by both c and k , which are to differ according to kinds of materials. As will be remarked later, the values of both c and k do not change with the increase of the degree of plastic deformation but depend mainly on the kind of materials.

In order to determine the value of r_0 , c and k , it is necessary to have at least three equations involving them simultaneously. There may be considered several ways to determine them. A few examples will be exhibited.

2-4) Examples.

The formula (2-6) or (2-13) shows the value of r_{mean} differs according to the size and shape of cross section, i.e. the higher its value is, the larger is the cross-sectional area of bars of similar shape and the shorter is the boundary of bars of equal sectional area. It is applicable for the determination of constants.

a) Pure aluminium.

From pure aluminium plates of thickness of 2.8, 3.4, 4.5, 5.5 and 9.5 mm, rolled under a certain condition, specimens of 10 mm breadth and 100 mm length were made and annealed at 350°C for an hour.

From microphotograph the grain size δ was determined to be 0.05 mm. Fig. 21 shows the relation of actual mechanical stress (applied load divided by actual sectional area under load) with regard to the thickness of plates under permanent set of 20 %. For the sake of simplicity, we put ;

section	p	q	r_{mean}
mm ²			kg/mm ²
10×10	200	200	5.70
10×6	200	120	5.40
10×3	200	60	4.75

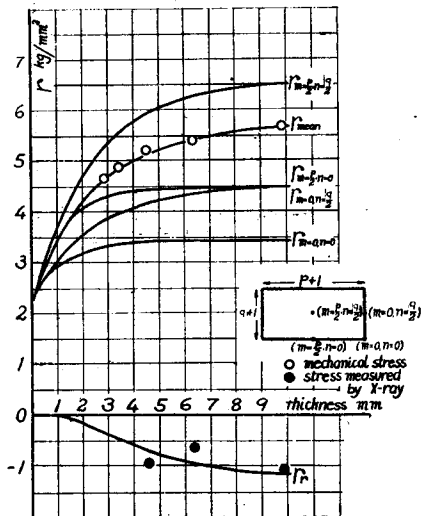

Fig. 21

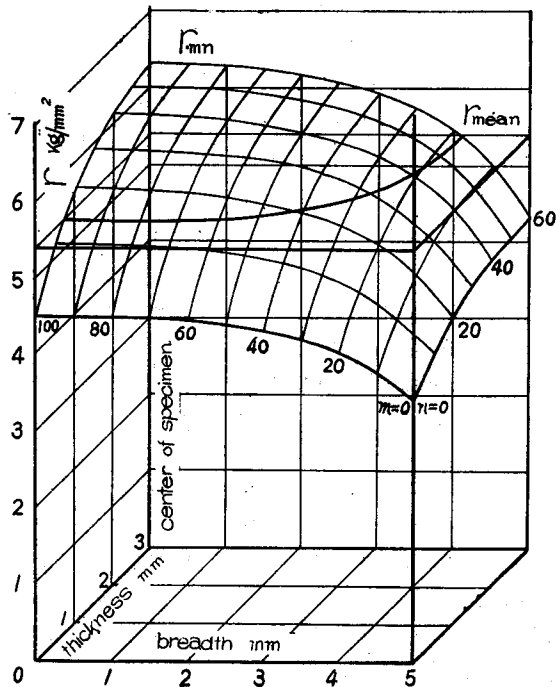

Fig. 22a

Substituting these values in (2-8),

$$r_0 = 2.3 \text{ kg/mm}^2, \quad k = 1.043,$$

$$c = 8.43 \times 10^{-4}$$

are obtained. The calculated values

of $r_{m=0, n=0}$, $r_{m=\frac{p}{2}, n=0}$, $r_{m=0, n=\frac{q}{2}}$, $r_{m=\frac{p}{2}, n=\frac{q}{2}}$ and r_{mean} in each plate are shown in the figure by full lines.

The distribution of yielding resistance in the cross section of 20% elongated specimen of $10 \times 6 \text{ mm}^2$, $10 \times 3 \text{ mm}^2$ and round section of 10 mm diameter are illustrated of a quadrant in Figs. 22 a, b and c respectively. It is remarkable to recognize that the resistance of round bar is 4% larger than that of rectangular bar of the same cross-sectional area. Hence, it is justified that, comparing the yielding

resistance of bars of same sectional area, the shorter the length of boundary, the larger the resistance r_{mean} , that is, that of round bar is the largest.

b) Mild steel.⁸⁾

As the second example of determination of the constants, experiments performed on mild steel will be shown, where, putting aside the mechanism of yielding phenomenon, the yielding resistance in the range between the

8) T. Nishihara, S. Taira, Trans. Soc. Mech. Engr. Japan, in the press.

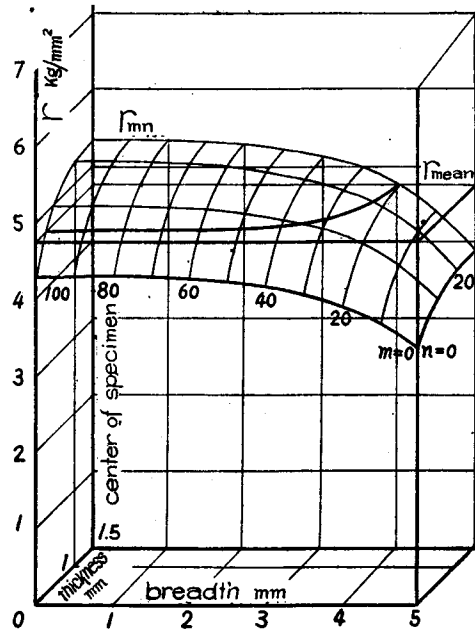

Fig. 22b

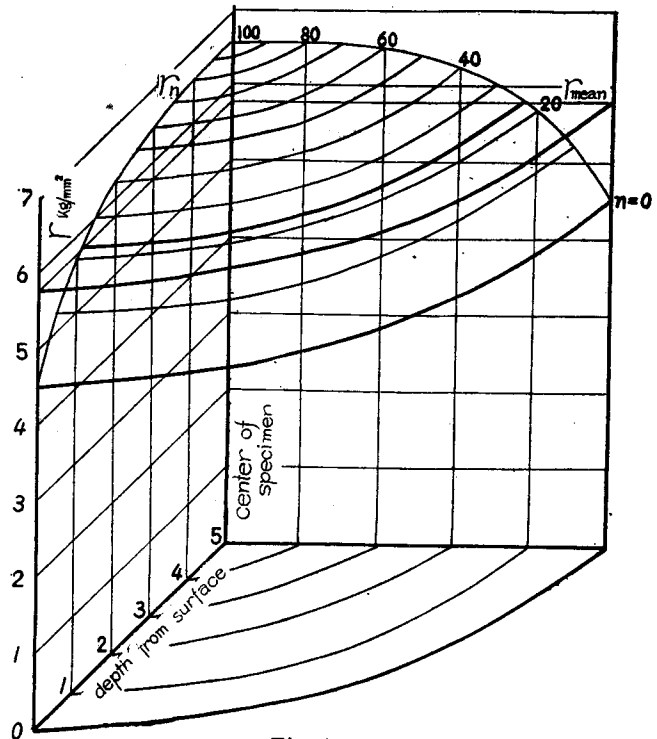

Fig. 22c

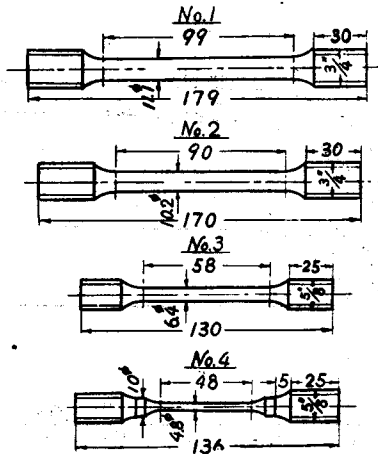
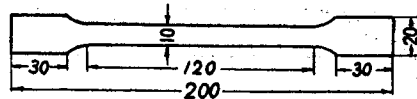

Fig. 23a



No	1	2	3	4	5
ϵ	9.1	7.8	6.7	3.1	2.3

Fig. 23b

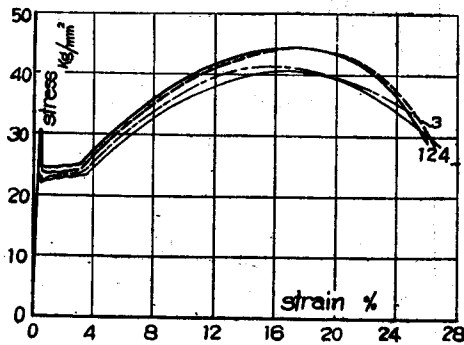

Fig. 24a

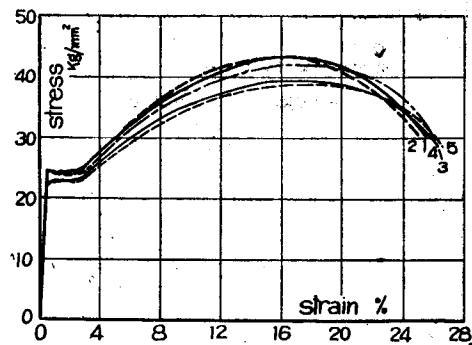

Fig. 24b

for an hour in a vacuum furnace after being machined. The stress-strain relation obtained is shown in Figs. 24 a and b. Having been given a permanent set of 3.9, 7.5, 10 and 15 %, the load was removed. The residual stress, measured by X-ray at these steps of elongation, is shown in Figs. 25 a and b, accompanied with the actual stress under the loaded condition. Utilizing the actual stresses of No. 1 and No. 3 of 10 % stretched round bars and surface residual stress, the three constants are determined as follows:

$$r_0 = 5.2 \text{ kg/mm}^2, \quad c = 9.35 \times 10^{-3}, \quad k = 1.073.$$

As in the case of aluminium, using these values of constants, the resistance values at several special points in the section and mean resistance are calculated. They are shown in the figures by full lines. In any step of elongation, the calculated resistance values are in good agreement with the experimental results. Hence, it is found that the value of c and k is not affected by the degree of

end point of horizontal part in stress-strain relation and the point of maximum load was treated. The form of specimen used is shown in Figs. 23 a and b, where a is of round bars and b of rectangular bars. The specimens are annealed at 900°C

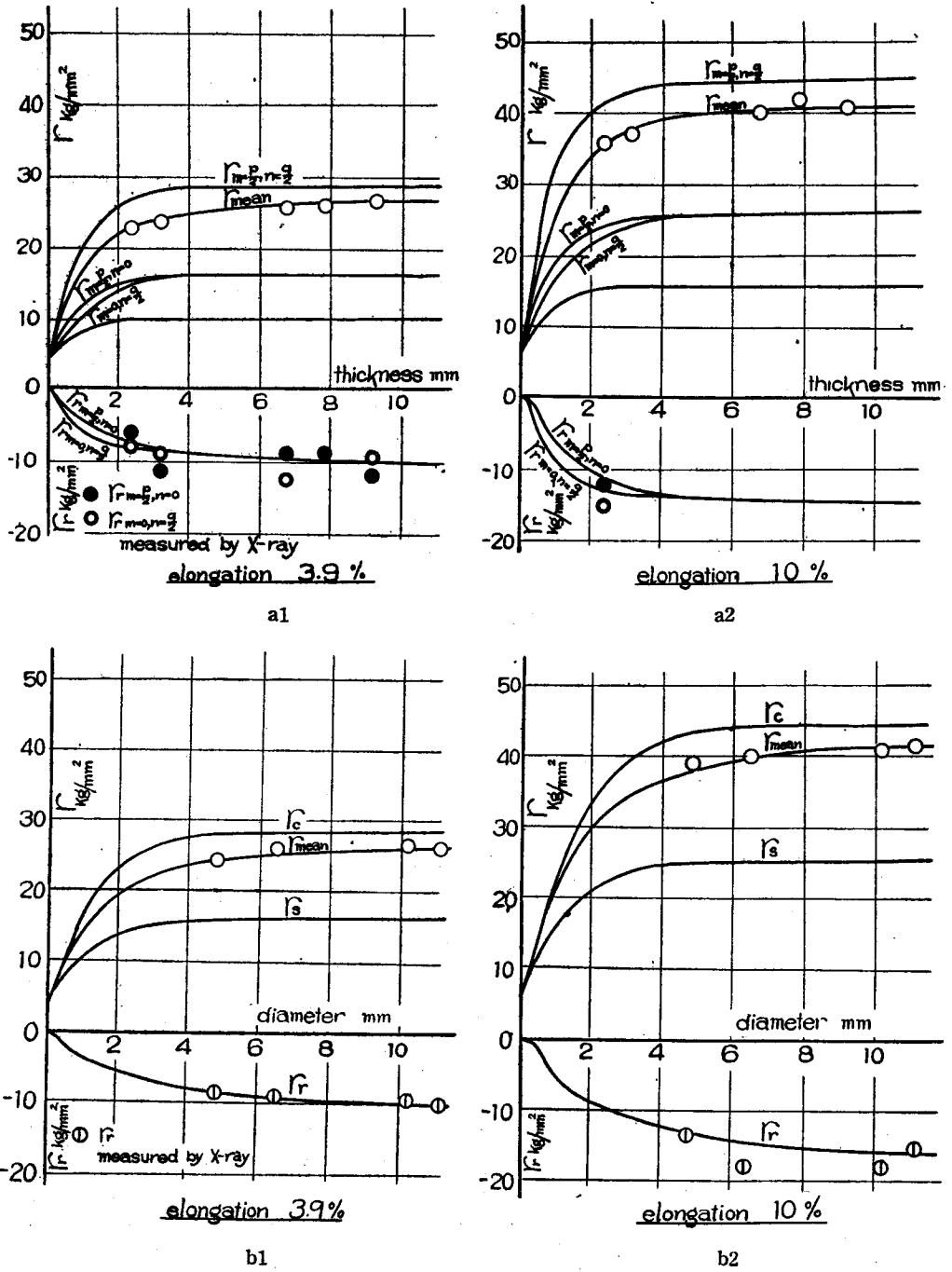

Fig. 25

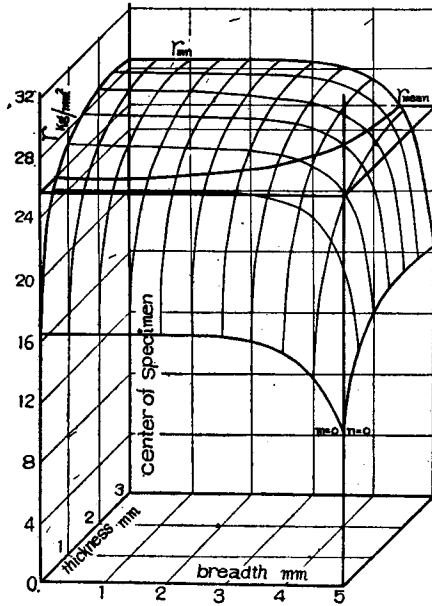

Fig. 26a

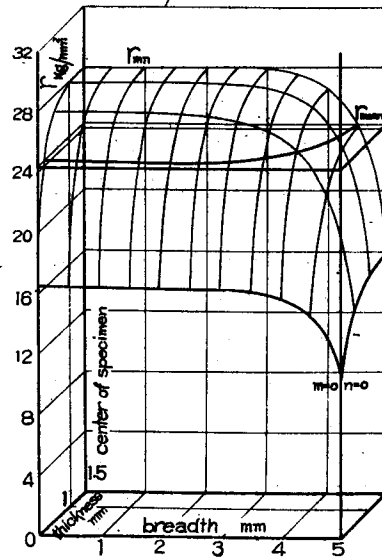

Fig. 26b

elongation but is constant with regard to the sort of materials. Then in general, the resistance of certain material is represented as follows:

$$r = r_0 + r' = r_0(1 + f) = r_0g$$

In analogous fashion,

$$r_{mean} = r_0(1 + f_{mean}) = r_0g_{mean}$$

f is restriction coefficient and g is resistance coefficient. The distribution of resistance in 3.9 % stretched mild steel of rectangular bar of 10×6 mm², 10×3 mm² in section and round bar of 10 mm diameter are illustrated in Figs. 26 a, b and c. Moreover, we can see the relation of r_{mean} to the size of cross section and permanent set. As an example,

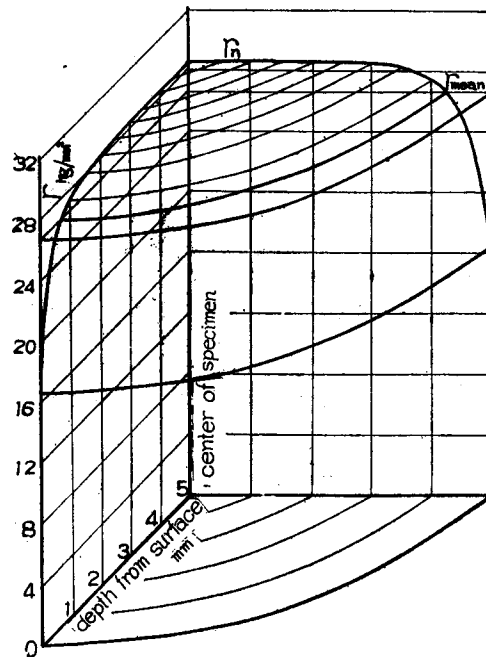

Fig. 26c

the three dimensional view of r_{mean} is calculated with regard to mild steel round bar as is shown in Fig. 27.

It is interesting to discuss the well known result of C. Bach⁹⁾ concerning the strength of mild steel bars. He compared the mechanical property of three series of different shape and of the same cross-sectional area and found that the strength of materials is affected by the shape of section. His result is exhibited in Table 1, in which σ_{SO} , σ_{SU} and σ_B means the upper and lower yield point and tensile strength respectively.

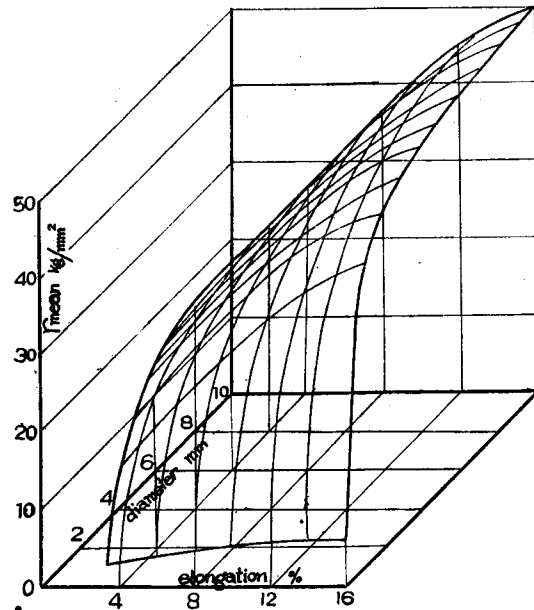

Fig. 27

According to the author's view, the above result can be explained by the change of resistance coefficient with respect to the shape of cross section. σ_{SU}' and σ_B' in the table are the calculated values of σ_{SU} and σ_B .

Table 1.

Cross section	σ_{SO} kg/mm ²	σ_{SU} kg/mm ²	σ_{SU}' kg/mm ²	σ_B kg/mm ²	σ_B' kg/mm ²
Circular (26 mm dia.)	23.35	19.81	19.95	35.90	35.40
Rectangular (40×13 mm ²)	21.85	19.77	19.77	34.88	34.88
I-form (4.8 mm thickness)	19.19	18.79	18.85	33.35	33.50

W. E. Dalby¹⁰⁾ compared the tensile strength of annealed 0.156 % C steel round bar of geometrically similar shape and of different sectional area. Table 2

Table 2.

Specimen	Diameter in.	σ_{SO} kg/mm ²	σ_B kg/mm ²	σ_B' kg/mm ²
F	3/4	35.0	46.0	46.2
A	5/8	33.0	46.0	45.9
E	1/2	33.2	44.9	45.2
K	3/8	31.5	44.7	44.9

9) C. Bach, Elastizität u. Festigkeit (1920) S. 164.

10) W. E. Dalby, Strength of Steel and Other Metals (1923) p. 73.

shows his experimental result. The calculated values of σ_B are shown by σ_B' in the table.

In each case the agreement of both values by experiment and by calculation is seen to be tolerably good.

3) The representation by exponential function.

The formulas (2-1)~(2-13) are convenient for practical operation on account of simplicity. However, difficulty has been encountered in calculating the resistance of bars of various sectional form except rectangular and circular bars. In order to generalize the analytical treatment of yielding resistance another consideration is necessary to be taken.

3-1) Law of mutual restriction.

As the law governing the mutual restriction of crystal files lying at a distance of l , we assume at present that they exert an increment dr' of resistance to one another as follows:

$$\begin{aligned} dr' &= r_0 df \\ df &= Ae^{-Bl} dl \end{aligned} \quad (3-1)$$

Putting $A = \frac{C}{\delta}$ and $B = \frac{\alpha}{\delta}$, we obtain

$$df = Ce^{-\frac{\alpha}{\delta} l} \frac{dl}{\delta}, \quad (3-2)$$

where l/δ and dl/δ means the number of grains lying on the laminae of the length l and dl respectively, denoting the dimension of a crystal file to be δ in the average. C is restriction constant and α diminution constant of restriction.

3-2) Restriction coefficient.

As in the case of the preceding chapter, the distribution of yielding resistance will be shown in terms of restriction coefficient later on.

a) Crystal files in a crystal lamina.

The restriction coefficient of a crystal file lying at a distance a from the end of a crystal lamina of length l may be given referring (3-2), as follows:

$$\begin{aligned} f &= \frac{C}{\delta} \int_0^a e^{-\frac{\alpha}{\delta} l} dl + \frac{C}{\delta} \int_0^{l-a} e^{-\frac{\alpha}{\delta} l} dl \\ &= \frac{C}{\alpha} \left[2 - \left(e^{-\frac{\alpha}{\delta} a} + e^{-\frac{\alpha}{\delta} (l-a)} \right) \right] \end{aligned} \quad (3-3)$$

$$a = 0 : f = \frac{C}{a} \left(1 - e^{-\frac{a}{\delta}t}\right)$$

$$\left. \begin{array}{l} a = 0 \\ l \rightarrow \infty \end{array} \right\} : f = \frac{C}{a}$$

The mean restriction coefficient f_{mean} is represented as follows:

$$f_{\text{mean}} = \frac{\int_0^l f da}{\int_0^l da}$$

$$= \frac{2C}{a} \left\{ 1 - \frac{\delta}{la} \left(1 - e^{-\frac{a}{\delta}t} \right) \right\} \quad (3-4)$$

b) a crystal file in an infinite section.

Crystal files lying at the same distance from any file should rouse equal magnitude of increment of resistance on the latter. We will now consider the restriction coefficient of a file in an infinite section. Consider a small element of aggregation of files as is shown in Fig. 28, it must bear its share of the increment of resistance of any file. Using polar co-ordinate l and φ and developing the formula (3-2) concerning the restriction coefficient due to the small element:

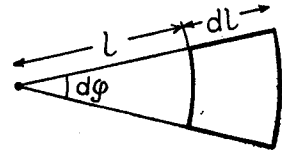

Fig. 28

$$df = \frac{C}{\delta^2} e^{-\frac{a}{\delta}t} l dl d\varphi \quad (3-5)$$

The restriction coefficient of a file in an infinite section is given, integrating (3-5) all over the expansion of the section, by

$$f = \frac{C}{\delta^2} \int_{l=0}^{\infty} \int_{\varphi=0}^{2\pi} e^{-\frac{a}{\delta}t} l dl d\varphi$$

$$= \frac{2\pi C}{a^2} \quad (3-6)$$

In analogous notion, that of a file lying on the surface of semi-infinite section is given by

$$f = \frac{\pi C}{a^2} \quad (3-7)$$

In connection with the manner of inducement of (3-6), the restriction coefficient of a file at the center of circular bar of radius a is easily obtained as

follows:

$$\begin{aligned}
 f &= \frac{C}{\delta^2} \int_{l=0}^a \int_{\varphi=0}^{2\pi} e^{-\frac{\alpha}{\delta} l} l dl d\varphi \\
 &= \frac{2\pi C}{a^2} \left\{ 1 - (1 + K) e^{-K} \right\}, \quad K = a \frac{\alpha}{\delta}
 \end{aligned} \quad (3-8)$$

c) A file in a polygonal uniform bar.

Let us now consider a crystal file existing in a polygonal bar as is shown in Fig. 29. The resistance coefficient would be given by integrating (3-5) over the section. For the sake of simplicity,

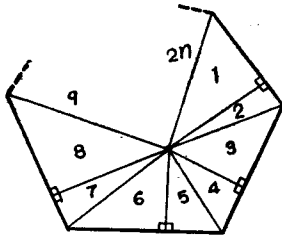

Fig. 29

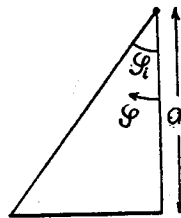

Fig. 30

we divide the domain into several segments of a triangle as is illustrated in the figure. The integration is carried out in the domain of each segment. The resistance coefficient of a file at the corner of a triangular segment as is shown in Fig. 30 is obtained by

$$\begin{aligned}
 f_t &= \frac{C}{\delta^2} \int_{l=0}^{a \sec \varphi} \int_{\varphi=0}^{\varphi} e^{-\frac{\alpha}{\delta} l} l dl d\varphi \\
 &= \frac{C}{\delta^2} \int_0^{\varphi} \left[1 - \left(1 + \frac{\alpha a}{\delta} \sec \varphi \right) e^{-\frac{\alpha a}{\delta} \sec \varphi} \right] d\varphi \\
 &= \frac{\varphi C}{a^2} - \frac{C}{\delta^2} \int_0^{\frac{\pi}{2}} \left(1 + K \sec \varphi \right) e^{-K \sec \varphi} d\varphi, \quad \text{where } K = \frac{\alpha a}{\delta}.
 \end{aligned}$$

The integration of second term can not be carried out in simple ways. Applying the approximate integration by Maclaurin expansion, it is represented as follows:

$$f_t = \frac{\varphi C}{a^2} \left[1 - \left\{ (1 + K) - \frac{K^2}{6} \varphi^2 - \frac{K^2}{40} (2 - K) \varphi^4 \right\} e^{-K} \right] \quad (3-9)$$

The term of higher order of φ can be neglected on account of good convergency. In this manner the resistance coefficient of a file in a polygonal bar is obtained by

$$f = \sum_i f_i \quad (3-10)$$

The restriction coefficient of rectangular, triangular or trapezoidal bar can easily be calculated by (3-10).

d) Circular bar

In the case of circular bar, the restriction coefficient of any file can also be obtained in the same manner as above. Consider a crystal file lying at a distance b from the center of circular bar of radius a . In this case also, the restriction coefficient is given by integrating (3-5) over the section. Performing approximate integration, it is necessary for the upper limit of φ to be $\pi/2$. Therefore, we divide the section into two regions by a line passing through the section of the file now in consideration and perpendicular to the diameter through it as is shown in Fig. 31. Using polar co-ordinate and taking the origin at the section of the file, the boundary of the circular section is represented:

$$l_i = \mp b \cos \varphi + a \sqrt{1 - \frac{b^2}{a^2} \sin^2 \varphi}, \quad (i=1, 2)$$

where with regard to the domain (a) we take minus for the double sign and plus for the domain (b). For both domains of the integration the restriction coefficient is

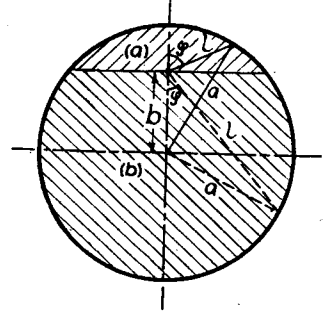

Fig. 31

$$f_i = \frac{2C}{\delta^2} \int_{\varphi=0}^{\frac{\pi}{2}} \int_{l=0}^{l_i} e^{-\frac{\alpha}{\delta} l} l dl d\varphi \quad (i=1, 2)$$

$$\therefore f = f_1 + f_2$$

$$\begin{aligned} &= \frac{2C}{\delta^2} \left\{ \int_{\varphi=0}^{\frac{\pi}{2}} \left[1 - \left\{ 1 + \frac{\delta}{a} (-b \cos \varphi \right. \right. \right. \\ &\quad \left. \left. \left. + a \sqrt{1 - \frac{b^2}{a^2} \sin^2 \varphi} \right\} e^{-\frac{\alpha}{\delta} \left[-b + \sqrt{1 - \frac{b^2}{a^2} \sin^2 \varphi} \right]} \right] d\varphi \right. \\ &\quad \left. + \int_{\varphi=0}^{\frac{\pi}{2}} \left[1 - \left\{ 1 + \frac{a}{\delta} (b \cos \varphi + a \sqrt{1 - \frac{b^2}{a^2} \sin^2 \varphi}) \right\} e^{-\frac{\alpha}{\delta} \left[b + \sqrt{1 - \frac{b^2}{a^2} \sin^2 \varphi} \right]} \right] d\varphi \right\} \end{aligned}$$

The integration is carried out applying the same approximative method as above.

$$\begin{aligned} f &= \frac{2\pi C}{a^2} \left\{ 1 - \sum_{i=1, 2} \left[(1 + K_i) \mp \frac{K_i^2 L^2}{6} \left(\frac{\pi}{2} \right)^2 - \frac{K_i^3 L^2}{120} \{ \pm 3(1 - K_i) \right. \right. \\ &\quad \left. \left. + \frac{L}{1 \mp L} (\pm 1 + 4L - 3L^3) \left(\frac{\pi}{2} \right)^4 \right] e^{-\kappa_i} \right\}, \quad (3-11) \end{aligned}$$

$$\text{where } K_1 = a \frac{a-b}{\delta}, \quad K_2 = a \frac{a+b}{\delta} \quad \text{and } L = \frac{b}{a} \quad (i=1, 2).$$

On account of good convergency, the terms of higher order of expansion were neglected in this case also.

$b=0$: $K_1=K_2=\alpha\frac{a}{\delta}=K$ and $L=0$, therefore,

$$f = \frac{2\pi C}{a^2} \{1 - (1 + K) e^{-K}\} \quad (3-12)$$

(3-12) shows the resistance coefficient of a file at the center of circular bar and agrees with the formula (3-8).

When $a \rightarrow \infty$ and $L \rightarrow 0$,

$$f = \frac{2\pi C}{a^2}$$

It is the same as (3-6).

As to the file on the surface,

$b=a$: $K_1=0$, $K_2=\frac{2a\alpha}{\delta}=K'$ and $L=1$, therefore,

$$f = \frac{\pi C}{a^2} \left[1 - \left\{ (1 + K') + \frac{K'^2}{6} \left(\frac{\pi}{2} \right)^2 + \frac{K'^2}{120} (3K' - 2) \left(\frac{\pi}{2} \right)^4 \right\} e^{-K'} \right] \quad (3-13)$$

3-3) Constants α and C .

In this paragraph, the intention is to discuss the relation of the constants α and C to those, k and c , in the series representation. Comparing the basic assumption on the manner of mutual restriction in both cases of analytical representation, strictly speaking, we find they are not the same. In the former case the crystal files exerting equal magnitude of restriction on any file lie on the boundary of a square as the center at the file, while in the latter they are those on a boundary of a circle as is shown in Fig. 31. From the standpoint of practical figure of grains, the latter assumption should be seen to be more rational. Determining the constants α and C , to utilize the mean resistance is thought to be convenient. The mean resistance is, however, not easily obtained in this case and evaluated only by means of graphical method. Therefore, it may be necessary to relate the value of α and C to those of k and c , so far as the restriction coefficients induced from the both combination of constants to be the same. Comparing the restriction coefficients induced from both assumptions, we have:

for a file in a lamina of infinite length,

$$f_a = 2ch$$

$$f_b = \frac{2C}{a}$$

and for the one occupying the center of round bar of finite section.

$$f_a = 4ch^2 \left\{ k - \frac{(k+1)}{2} \left(\frac{1}{k^{b/a}} + \frac{1}{k^{a/b}} \right) + \frac{1}{k^2} \right\}$$

$$f_b = \frac{2\pi C}{a^2} \left\{ 1 - \left(1 + \frac{\alpha a}{\delta} \right) e^{-\frac{\alpha a}{\delta}} \right\}, \quad \pi a^2 = bd,$$

where f_a is of the former assumption and f_b of the latter. Equalizing f_a to f_b in both cases respectively, α and C is given in terms of k and c . In practice, good compliance of f_a and f_b is achieved concerning any crystal file in a bar of any dimension and of any sectional form, provided as the radius of round bar

Table 3.

	δ mm	k	c	α	C	n
mild steel	0.03	1.074	9.35×10^{-3}	0.1088	1.379×10^{-2}	130
aluminium	0.05	1.043	8.43×10^{-4}	0.0665	1.306×10^{-3}	200

$a = n\delta$

appropriate value is chosen. Thus obtained values of constants are exhibited in Table 3 concerning the cases of mild steel and aluminium. The distribution of resistance coefficient in the section of mild steel bar of 6×10 mm² in section, evaluated from the latter representation using the value of constants shown in Table 3, is illustrated in Fig. 32, where that obtained from the former representation is shown by dotted lines as well. We see they agree with the difference no more than 2% in any case.

3-4) Example.

The analytical treatment of yielding resistance is thus enlarged in the field of application. As an example, we may investigate the distribution of yielding resistance in a bar of mild steel,

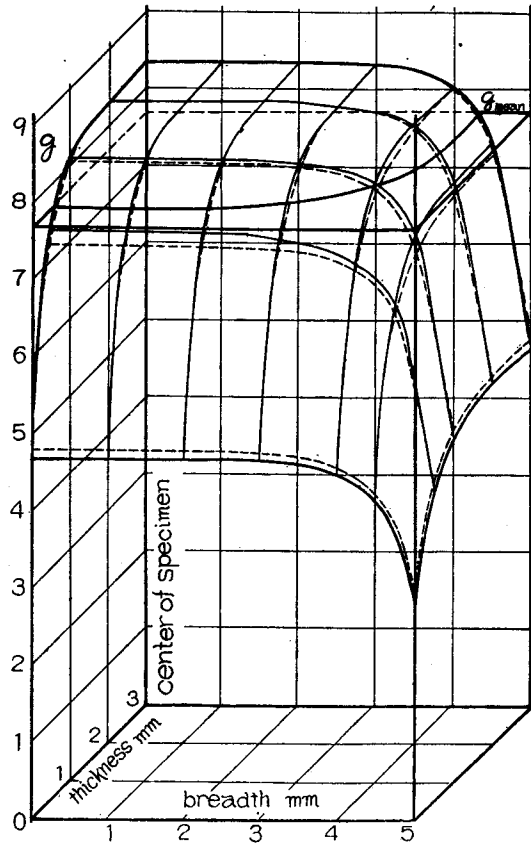

Fig. 32

of which the section is shown in Fig. 33. An annealed specimen is stretched plastically and at the elongation of 3.2, 8.7 and 13.5 % the applied load is removed.

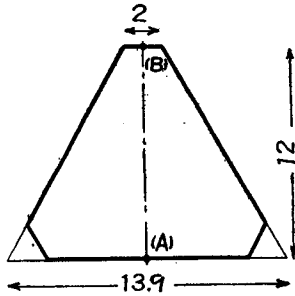

Fig. 33

At each step of elongation, the surface residual stress is measured by means of X-ray at two spots (A) and (B) as is shown in Fig. 33. The mechanical stress under load and the measured residual stress are shown in Table 4. On the other hand, from the formula (3-10) the distribution of resistance coefficient is given and one half of the section is illustrated in Fig. 34, where the mean value is

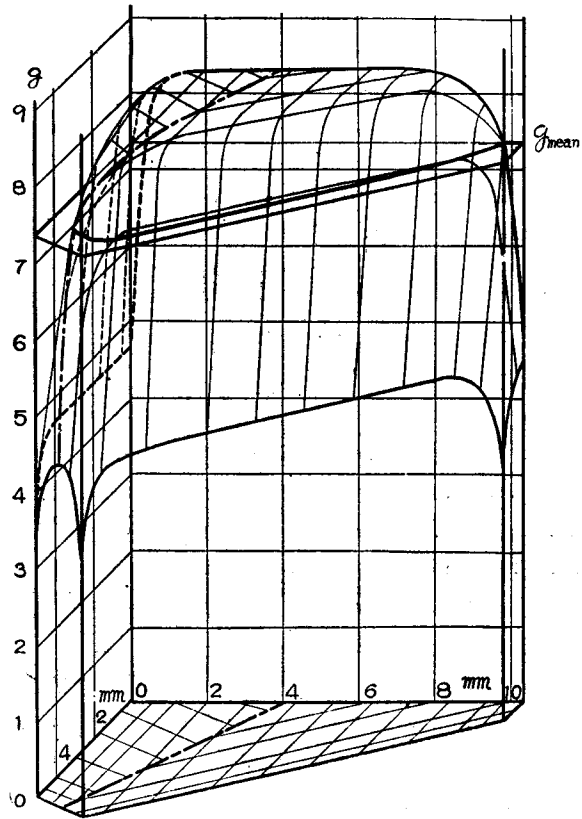

Fig. 34

Table 4.

elongation	experimental values			calculated values				
	σ_{mean}	(B) σ_r	(A) σ_r	(B) σ	(A) σ	(B) σ_r	(A) σ_r	
%	kg/mm ²	kg/mm ²	kg/mm ²	kg/mm ²	kg/mm ²	kg/mm ²	kg/mm ²	
3.2	24.0	- 9.0	-11.5	13.8	15.1	- 8.9	-10.2	
8.7	35.4	-12.9	-14.0	20.3	22.3	-13.1	-15.1	
13.5	39.6	-15.5	-17.3	22.6	24.8	-14.7	-16.9	

evaluated by graphical method. As is seen in the figure, in the vicinity of (B) the resistance falls remarkably, while near the point (A) it changes scarcely on the surface. Because the incident X-ray is of circular form of 2 mm dia. on the surface of specimen, the measured stress value at (B) must be the mean of the portion. The resistance coefficients concerned are exhibited, where g_B is the mean of the full width of the portion, as follows:

$$g_{mean} = 7.36, \quad g_A = 4.63, \quad g_B = 4.22.$$

The surface stress under load at (A) or (B) is evaluated by

$$\sigma = \sigma_{mean} \times \frac{g}{g_{mean}}$$

The residual stresses are obtained by

$$|\sigma_r| = |\sigma_{mean} - \sigma|$$

The calculated values of stresses σ under load and the residual stresses σ_r at each step of elongation is shown in the Table as well. The good agreement of residual stress to the calculated ones is seen.

4) Concluding remarks.

The theoretical view of yielding resistance above discussed is hypothetical for the present and only an attempt to treat metals as an aggregation of crystal grains. The mutual restricting influence, on which the theory stands on, is, however, confirmed to exist by experimental proofs given by many researcher of metals. As to the essential character of yielding resistance, the authors believe it is reasonably treated, notwithstanding the fact that the theory is primitive from the mathematical point of view.

There rises a fundamental question whether dependency of yielding resistance on the size and shape of specimens is inconsistent with the principle of similarity, the Barba's Law. Looking back upon the formula (2-6) for instance, it will easily be recognized that r_{mean} may be said to be independent of the dimension of specimens, provided the value of p and q is so large that $\frac{1}{k^p}$ and $\frac{1}{k^q}$ is nearly equal to zero, that is, the specimen is comparatively large. The tendency is seen in Figs. 21 and 25 with half an eye. Surveying the experimental results supporting the law, on the other hand, it is found that all of them are on specimens of such dimension as not to be affected by the size and shape. In practice, it is certain that the tenacity of metals is affected by the size and shape of specimens, when the dimension is rather small, as has been proved above.

Summary

In the present paper the authors pointed out the necessity of seeing the metals as the inherent figure, an aggregation of crystal grains, when they are deformed plastically. Although other factors affecting the yielding resistance of polycrystalline metals, it may be considered the mutual restriction is here thought to play an important role. As, at present, no theory is found connecting yielding resistance of single crystals to that of polycrystalline metals, the authors' view discussed would be recommended, until a far better theory is developed.