

# Studies on the Oxidation of Pyrite

(Part 1) Thermal Decomposition of Pyrite

By

Kiyokado NISHIHARA and Yoshio KONDO

Department of Metallurgy

(Received August 25, 1958)

## Abstract

The kinetics of the thermal decomposition of pyrite and the properties of the thermal decomposition products were studied and the following results were obtained.

1. Thermal decomposition of pyrite is not followed by the first order reaction. In the  $(-\log x)-t$  diagram (where  $x$  is mol fraction of pyrite), a knick point was observed at  $x \approx 0.3$ . From the linear parts before and after this knick point, an activation energy of 50.9 kcal is obtained for the initial period of the reaction and that of 40.3 kcal. for the final period of the reaction.

2. The composition of the thermal decomposition products can be represented by  $\text{FeS}_{1+x}$ , and this coefficient of the formula becomes smaller with an increase in the temperature of decomposition. Of these decomposition products,  $\text{FeS}_{1.13}$  and  $\text{FeS}_{1.11}$  are ferromagnetics whose Curie point is 295°C, and  $\text{FeS}_{1.09}$  and  $\text{FeS}_{1.08}$  are anti-ferromagnetics whose Curie point is about 220°C. And,  $\text{FeS}_{1.06}$ ,  $\text{FeS}_{1.05}$  and  $\text{FeS}_{1.00}$  are paramagnetics.

3. The thermomagnetic properties of antiferromagnetic or paramagnetic  $\text{FeS}_{1+x}$  remain unchanged when they are heated to 300°C in vacuum sealed capsules or in high vacuum; on the other hand, they change into the ferromagnetic ones when they are heated in low vacuum or in the air. By this change, their lattice parameter and axial ratio also change to those of the ferromagnetic ones. From these results, it may be said that this change is due to the initial stage of oxidation of  $\text{FeS}_{1+x}$  and that, by this change, ferromagnetic  $\text{FeS}_{1+x}$ , whose composition is near the upper limit of solubility of sulphur in  $\text{FeS}_{1+x}$ , is formed.

## 1. Introduction

Pyrite is a main raw material for manufacturing sulphuric acid in Japan. Accompanying the development of chemical industries in Japan, the demand for sulphuric acid has increased remarkably and to meet this demand, therefore, it is felt

necessary to elevate the utilization efficiency of sulphur in the sulphuric acid plants by, above all, improving the roasting techniques to depress the residual sulphur content in the cinder to the lowest possible point.

Cupriferrous pyrite, zinc blende, etc. always contain pyrite as a component. Therefore, studies on the oxidation mechanism of pyrite is important for researches on the smelting of these sulphide minerals.

Many studies have been made on the oxidation of pyrite from the above-mentioned points of view.<sup>1)~4)</sup> From these studies formerly made, we consider that the following features of the study can be summarized:

a) Pyrite decomposes at above 600°C or thereabout and accompanying this thermal decomposition, conditions of the reaction interface of the particles vary. Therefore, in the oxidation of pyrite, it is difficult to apply theoretical equations of reaction kinetics which can be applied to the oxidation of zinc blende<sup>5),6)</sup> or pyrrhotite.<sup>7)</sup>

b) Many of these studies on the oxidation were made in the atmosphere of excess flow of air or oxygen, but the investigations made on the oxidation of pyrite in the atmosphere of poor oxygen and rich sulphur dioxide are few. However, such studies on the oxidation in low partial pressure of oxygen are considered very important to explain the reactions of oxidation in the roasters, such as the reactions in the interior of the particle of lump ore or in the layer of fine particles in multiple hearths furnace, etc..

For example, as generally known, when pyrite is charged in the Herreshoff furnace, it becomes ferromagnetic in the middle hearths of the furnace, and finally it is discharged from the furnace as non-magnetic ferric oxide.

According to the studies carried out in the excess flow of air,  $\text{Fe}_3\text{O}_4$  is hardly detected in the intermediate stage of oxidation,<sup>3)</sup> and thermal decomposition products of pyrite at above 700°C or thereabout are non-magnetic.<sup>8)</sup> From these facts, it may be said that the reactions of oxidation of pyrite in the roasters are not yet completely explained by the studies formerly made. Therefore, the purpose of our study here is directed to the investigations of mechanism of oxidation of pyrite in the roasters.

As the thermal decomposition of pyrite begins at about 600°C, the mechanism of oxidation of pyrite below and above this temperature range is different; namely, below this temperature, the thermal decomposition is hardly observed and the reaction of oxidation consists mainly of the direct oxidation of pyrite; and on the other hand, above this temperature, the thermal decomposition of pyrite begins first of all and the oxidation of thermal decomposition product follows it. Therefore, researches on the thermal decomposition of pyrite is considered important for the study on the mechanism of oxidation of pyrite. In this report (Part 1), researches on the kinetics of thermal decomposition of pyrite and on the properties of thermal decomposition products,  $\text{FeS}_{1+x}$ , are described.

## 2. Experimental

### 2.1. Material

The specimen used in the present study was pyrite mined at Yanahara Mine, Okayama Prefecture. Lump ore of pyrite was sent to the laboratory and, prior to the measurements, it was ground with agate mortar and its fraction between 200 and 250 mesh was collected by sieving. The ground specimen was always kept in a desiccator. The chemical analysis of this specimen is shown in Table 1. From this table, the mol ratio of Fe/S in the specimen was calculated to be  $1:1.995 \approx 1:2$ .

Table 1.

Fe (%)	S (%)	Cu (%)	Insol. Residue (%)
44.56	51.04	0.03	4.04

### 2.2. Thermobalance

The rate of the thermal decomposition and of the oxidation of pyrite were measured by the thermobalance shown in Fig. 1.

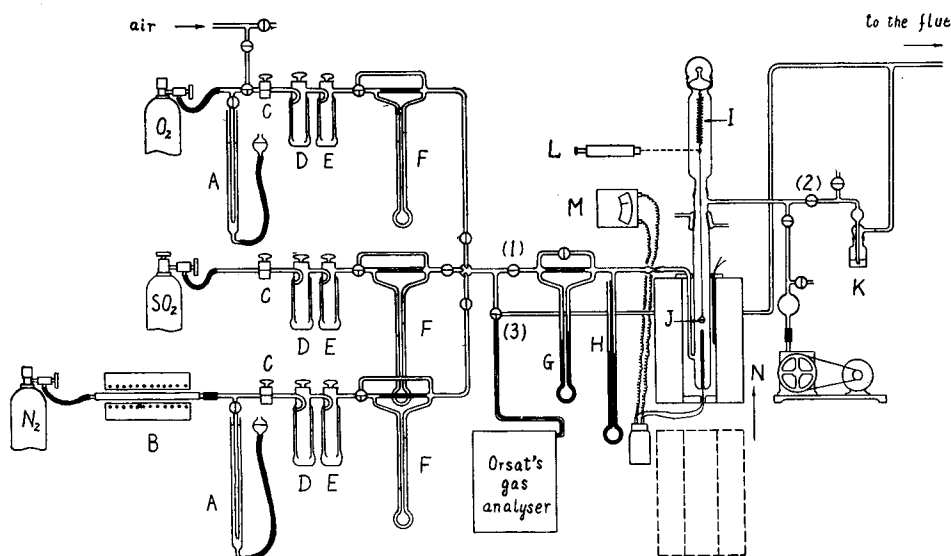

Fig. 1. Thermobalance

- |                                 |                          |
|---------------------------------|--------------------------|
| A : regulator of gas flow       | B, N : electric furnace  |
| C : two-way valve               | D : $\text{CaCl}_2$ tube |
| E : $\text{P}_2\text{O}_5$ tube | F, G : flowmeter         |
| H : manometer                   | I : silica spring        |
| J : sample dish                 | K : gas bubbler          |
| L : cathetometer                | M : pyrometer            |

Oxygen, sulphur dioxide and nitrogen gases are allowed to flow into the apparatus from each gas bottle placed at the left side of the figure. After drying them with calcium chloride and with phosphorus pentoxide and measuring their rate of flow with

the flowmeter F and mixing the component gases, the mixed gas is introduced into the reaction tube through its lower part. In the measurement of the rate of thermal decomposition of pyrite, nitrogen carrier gas was purified with heated copper foil charged in the furnace B, and in the measurement of the rate of oxidation in the air, air was led into the apparatus with a blower, instead of these gas bottles.

Control of flow of the component gases was done by regulating the reducing valves attached to the gas bottles and the valve C, expelling excess gas from A into the atmosphere. In the cases of a mixed gas whose concentration of oxygen is below 3%, the above-mentioned method of control becomes very difficult and, therefore, instead of using the oxygen gas bottle, oxygen was generated by electrolysis of potassium hydroxide solution. By this method, the flow of oxygen is proportional to the electrolytic current. The content of oxygen and sulphur dioxide in the mixed gas was analysed with Orsat's apparatus before and after the run.

Prior to the run, it is necessary to displace the air in the apparatus with the mixed gas of desired composition. The operation begins, therefore, with evacuation of the air present in the apparatus between the valve (1) and (2) with a rotary pump. Meanwhile, the component gases are allowed to flow from the gas bottles, through F and the three-way valve (3), into the open air. After regulating the rate of the flow and analysing the mixed gas, the valve (3) is closed and the valve (1) is opened. The gas begins to fill the reaction tube and, after the pressure in the reaction tube reaches atmospheric pressure, the valve (2) is opened and the gas is discharged into the open air. After about 20 minutes during which the gas flow is kept stationary, the electric furnace N is pulled up to cover the reaction tube and the thermocouple is inserted into the tube, and then the measurement with the cathetometer L of the change of weight of the sample is commenced. After the run, the furnace N is pulled down immediately, the flow of gas is stopped and the reaction tube is cooled rapidly by the blow of cold air.

The sample dish used for the measurements is shown in Fig. 2. The amount of the sample used in every run was 400 mg and the thickness of layer of the sample was about 1 mm.

Sensitivity of the silica spiral spring used was about 0.027 mm/mg. The rate of flow of the gas was fixed at 200 cc/min. of the  $O_2$ - $SO_2$ - $N_2$  mixed gas in the measurements of the rate of oxidation, and at 100 cc/min. of the  $N_2$  gas in the measurements of the rate of thermal decomposition.

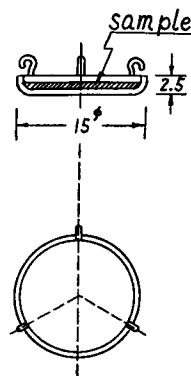

Fig. 2. Sample dish  
(unit : mm)

### 2.3. Thermomagnetic Analysis and Measurement of Relative Intensity of Magnetization

The apparatus used for the thermomagnetic analysis of the thermal decomposition

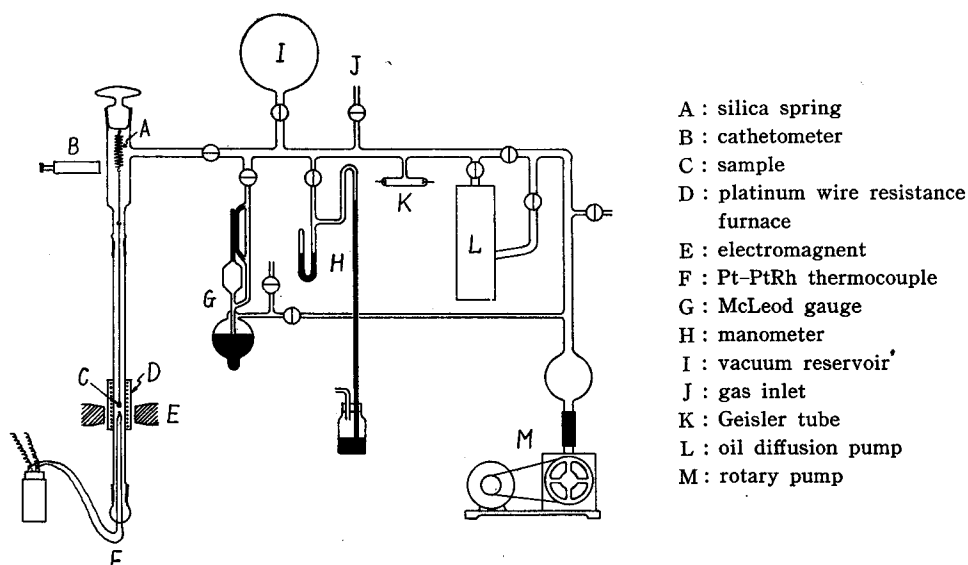

Fig. 3. Apparatus for thermomagnetic analysis

products or the oxidation products of pyrite is shown in Fig. 3. This apparatus is a modified Faraday balance<sup>9)</sup> using vertical suspension from a silica spiral spring. Magnetizing current of the electromagnet is D. C. rectified by the selenium rectifier. The voltage of A. C. supplied to the rectifier is stabilized by the voltage stabilizer of electronic type. Maximum intensity of the magnetic field at the point 4 cm above the center of the pole piece is about 1,700 Oersted. The measurements were carried out in the air, in vacuo and in the atmosphere of purified argon gas depending upon circumstances. In some measurements, the samples were put in the sealed and evacuated silica capsules.

Measurements of relative intensity of magnetization were carried out with the magnet of the above described apparatus. In these measurements, a silica spiral spring is hung by the hook of a fine adjustable screw which is separated from the apparatus. This fine adjustable screw is shown in Fig. 4. The cross line of the cathetometer shown in Fig. 3 is fixed at a certain position, and the image of lower end of the silica spring is brought to the cross line by adjusting the screw. By this adjustment, the distance between the sample and the center of the

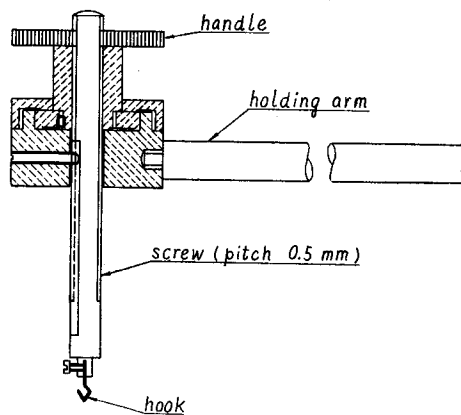

Fig. 4. Fine adjustable screw

pole piece becomes constant. Thereafter, the circuit of magnetizing current is closed and the elongation of the spring is measured. The sample is weighed by microbalance of sensitivity of 0.001 mg. Now, if the elongation of the spring is denoted by  $l$  and the weight of the sample by  $w$ , the relative intensity of magnetization is given by  $l/w$ . The value thus obtained of the relative intensity of magnetization is supposed to be somewhat deviated from the value measured in the saturated magnetic field, because the intensity of magnetic field in this measurement is about 1,700 Oersted as described above.

#### 2.4. X-Ray Diffraction Method

X-ray diffraction patterns were obtained by means of an ordinary powder camera with diameter of 90 mm and  $\text{FeK}\alpha$  radiation. An X-ray tube of rotation-anode-type was used and the exposure was about thirty minutes.

### 3. Results and Discussion

#### 3.1. Rate of Thermal Decomposition

With the thermobalance described in 2.2, the weight decrease due to the thermal decomposition was measured. The conditions of the measurements were as follows; flow of the carrier gas; 100 cc/min. of nitrogen which was purified with heated copper foil,

temperature; 625, 650, 675, 700, 750, 800 and 900°C.

The results obtained are shown in Fig. 5, in which the weight change of the

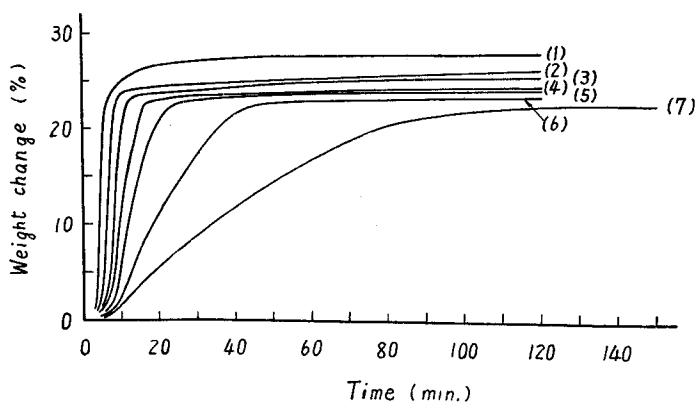
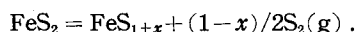

Fig. 5

Temperature of thermal decomposition;  
 (1): 900°C, (2): 800°C, (3): 750°C, (4): 700°C,  
 (5): 675°C, (6): 650°C, (7): 625°C

sample is plotted against the reaction time. From Fig. 5, it was found that the thermal decomposition proceeds slowly at about 600°C and it proceeds very quickly above 700°C, and that the composition of the thermal decomposition products is not

stoichiometric but it varies with the temperature of decomposition, and possesses generally a formula of  $\text{FeS}_{1+x}$ . Consequently, the chemical equation for thermal decomposition is,



We assumed, according to G.-M. Schwab<sup>4)</sup>, K. Niwa<sup>3)</sup> and other investigators, that this reaction of the thermal decomposition is followed by the equation of the first order reaction as follows,

$$-dx/dt = k_1x \quad (1)$$

where  $x$  is the mol fraction of  $\text{FeS}_2$  at time  $t$ , and  $k_1$  is the rate constant of the thermal decomposition. Thence, we obtain

$$-\ln x = k_1t.$$

On the other hand, from results of the measurement, we calculated the mol fraction of  $\text{FeS}_2$ ,  $x$ , and plotted  $-\log x$  against the reaction time  $t$ , in Fig. 6. It is shown in

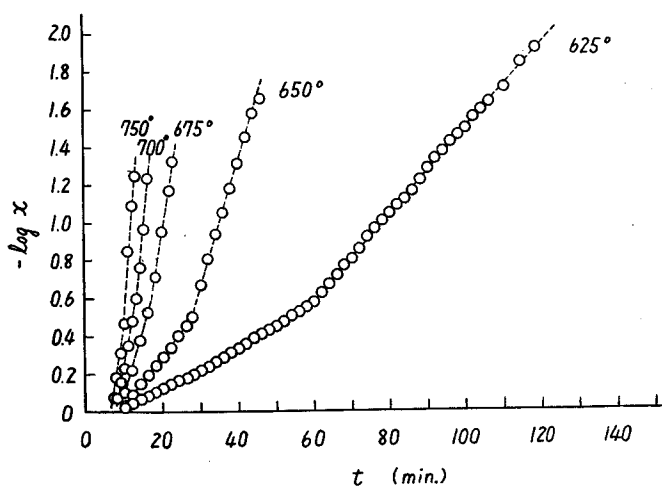

Fig. 6

Fig. 6, that in the thermal decomposition of pyrite, the first order reaction of Eq. (1) is not strictly applied, but each line in the figure is composed of two parts of straight line whose intersection lies at  $x \approx 0.3$ . This phenomenon of break in the rate of the thermal decomposition is noticed by G.-M. Schwab and other investigators. The cause of it is assumed by some investigators to be attributable to the secondary particles localized within pyrite,<sup>10)</sup> or to the formation of intermediate sulphide like  $\text{Fe}_3\text{S}_6$ <sup>11)</sup>; however, it may be safely said that the cause of the phenomenon is not yet made clear.

From the linear parts before and after the knick point of  $x \approx 0.3$  in Fig. 6, the

rate constants of thermal decomposition of the initial period ( $k_{i,i}$ ) and of the final period ( $k_{i,f}$ ) were calculated. The logarithms of the rate constants determined in this way are shown in Fig. 7, plotted against the reciprocals of the absolute temperature. From this figure, an activation energy of 50.9 kcal is obtained for the initial period of the reaction and that of 40.3 kcal for the final period of the reaction. These values of the activation energy coincide well with those obtained by G.-M. Schwab,<sup>4)</sup> and it can be attributed to the chemical process but not to a transport phenomenon.

As mentioned above, the composition of the thermal decomposition products is not stoichiometric and their general formula can be represented by  $\text{FeS}_{1+x}$ . In Fig. 8, the coefficient  $(1+x)$  of the formula was plotted against the thermal decomposition temperature. This coefficient decreases with an increase in the temperature of decomposition as shown in the figure.

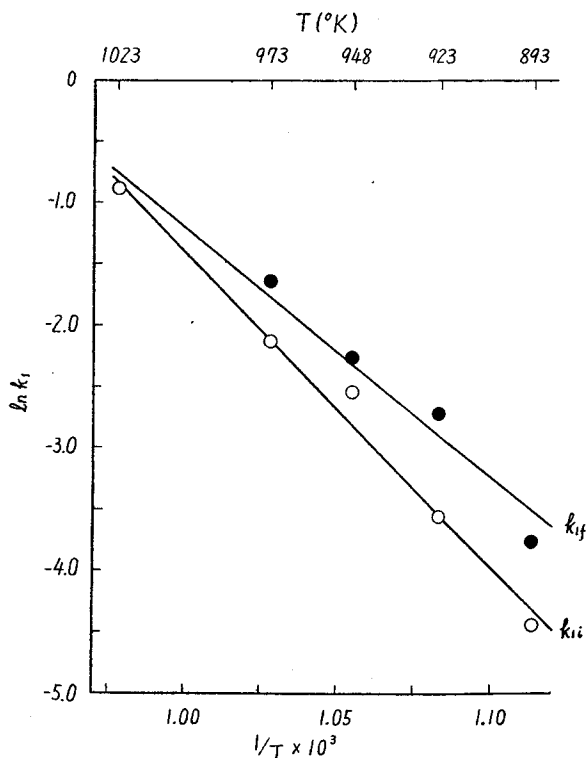

Fig. 7

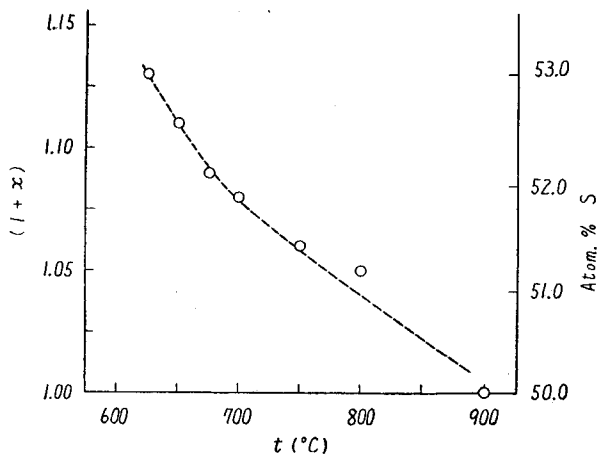

Fig. 8

### 3.2. Thermomagnetic Analysis of the Thermal Decomposition Products

As mentioned in 3.1, the composition of the thermal decomposition products of



pyrite is not stoichiometric. R. Juza and W. Biltz<sup>8)</sup> studied on the composition and some other properties of the thermal decomposition products of pyrite and concluded that the composition varies with the decomposition temperature and the vapor pressure of sulphur. Their results are summarized in Fig. 9. In this figure, the left side of

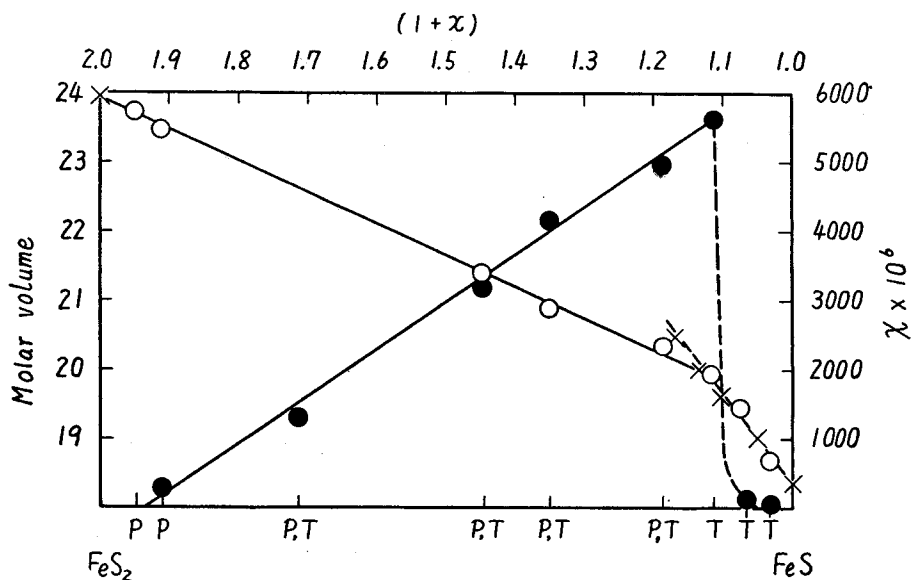

Fig. 9

- : Magnetic measurements by Juza and Biltz
  - : Measurements of density by Juza and Biltz
  - × : Measurements of density by Allen et al.
  - P : Pyrite lattice, T : Troilite lattice
- (R. Juza and W. Biltz; Z anorg. u. allg. Chem., 205, 273, (1932))

$\text{FeS}_{1.1}$  is heterogeneous field composed of  $\text{FeS}_2$  phase and  $\text{FeS}_{1+x}$  phase, and the field between  $\text{FeS}_{1.0}$  and  $\text{FeS}_{1.1}$  is homogeneous solid solution whose formula is  $\text{FeS}_{1+x}$ . They measured the density, magnetic susceptibility and X-ray diffraction pattern of the products and found that there are distinct differences in the properties between the products of heterogeneous field and that of the solid solution.

On this homogeneous solid solution of  $\text{FeS}_{1+x}$ , H. Haraldsen<sup>12)</sup> pursued the studies in detail. In Fig. 10, his results of studies are summarized. According to this figure, the samples, whose composition is between  $\text{FeS}_{1.00}$  and  $\text{FeS}_{1.06}$ , are paramagnetic, and those between  $\text{FeS}_{1.10}$  and  $\text{FeS}_{1.14}$  are ferromagnetic. The upper limit of solubility of sulphur in  $\text{FeS}_{1+x}$  lies at about 53.4 atomic percent of sulphur. The samples, whose composition is between  $\text{FeS}_{1.06}$  and  $\text{FeS}_{1.10}$ , are antiferromagnetic and their antiferromagnetic Curie point was found to be at about 200°C ( $\gamma$ -maximum in Fig. 10). The ferromagnetic Curie point of  $\text{FeS}_{1+x}$  was found by him to be at 325°C. Recently, R. Benoit<sup>13)</sup> found the Curie point of  $\text{FeS}_{1+x}$  to be at 292°C.

The coefficient  $(1+x)$  of the thermal decomposition products obtained in 3.1 was less than 1.13, and they were considered as a homogeneous solid solution. In this

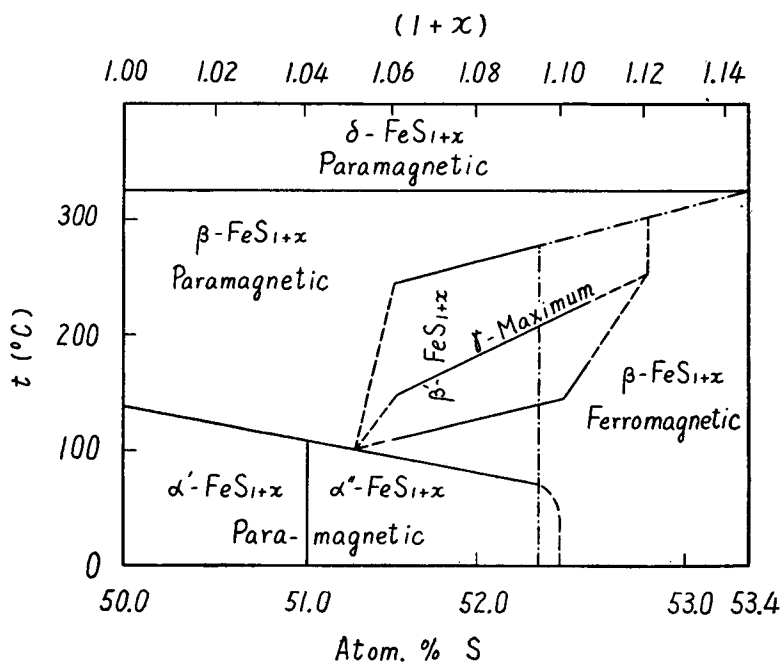

Fig. 10

(H. Haralden; Z. anorg. u. allg. Chem., 246, 195, (1941))

section, we investigated the relations between the composition of the thermal decomposition products and their thermomagnetic properties.

a)  $\text{FeSi}_{1.13}$  (temperature of the thermal decomposition;  $625^{\circ}\text{C}$ ) and  $\text{FeSi}_{1.11}$  (temperature of thermal decomposition;  $650^{\circ}\text{C}$ )

The results obtained of thermomagnetic analysis in vacuo of about  $10^{-3}$  mmHg are shown in Fig. 11, in which the reading scale of the cathetometer is plotted against the heating temperature. When these samples are heated, their intensity of magnetization decreases gradually from room temperature until about  $200^{\circ}\text{C}$ , and then it increases rapidly above this temperature reaching the maximum at

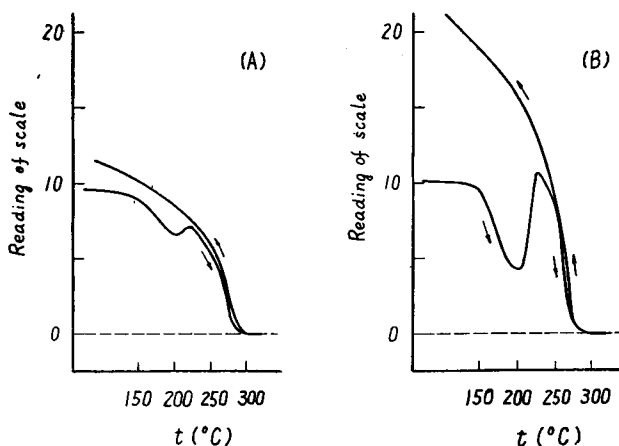

Fig. 11

(A)  $\text{FeSi}_{1.13}$  (decomp. product at  $625^{\circ}\text{C}$ )  
 (B)  $\text{FeSi}_{1.11}$  (decomp. product at  $650^{\circ}\text{C}$ )

about 220°C, and thereafter it decreases again and the Curie point of 295°C is attained. This temperature of Curie point coincides well with that obtained by R. Benoit.<sup>13)</sup> The cooling curve of the sample thus heated to about 300°C does not coincide with the heating curve and it shows monotonous increment. The intensity of magnetization at room temperature shows a higher value than that before the heating. Thus, a hysteresis was observed in the curve of the thermomagnetic analysis. This hysteresis was more obvious in FeS<sub>1.11</sub> than in FeS<sub>1.13</sub>.

Thereafter, repeated heating and cooling in vacuo of the same sample once thus analysed does not take effect any more in its thermomagnetic properties. That is, the shape of the curve of the analysis obtained after the second repetition coincides with that of the cooling curve of the first time and the hysteresis is not recognized.

**b) FeS<sub>1.09</sub> (temperature of thermal decomposition; 675°C) and FeS<sub>1.08</sub> (temperature of thermal decomposition; 700°)**

The results obtained of the thermomagnetic analysis of FeS<sub>1.09</sub> in vacuo of about 10<sup>-3</sup> mmHg are shown in Fig. 12. The analysis was repeated seven times on the same sample. The numbers written in the circle of the figure shows the run of the repetition. As shown in ① of the figure, this sample originally is antiferromagnetic whose Curie point lies at about 220°C. When it is cooled from about 320°C,

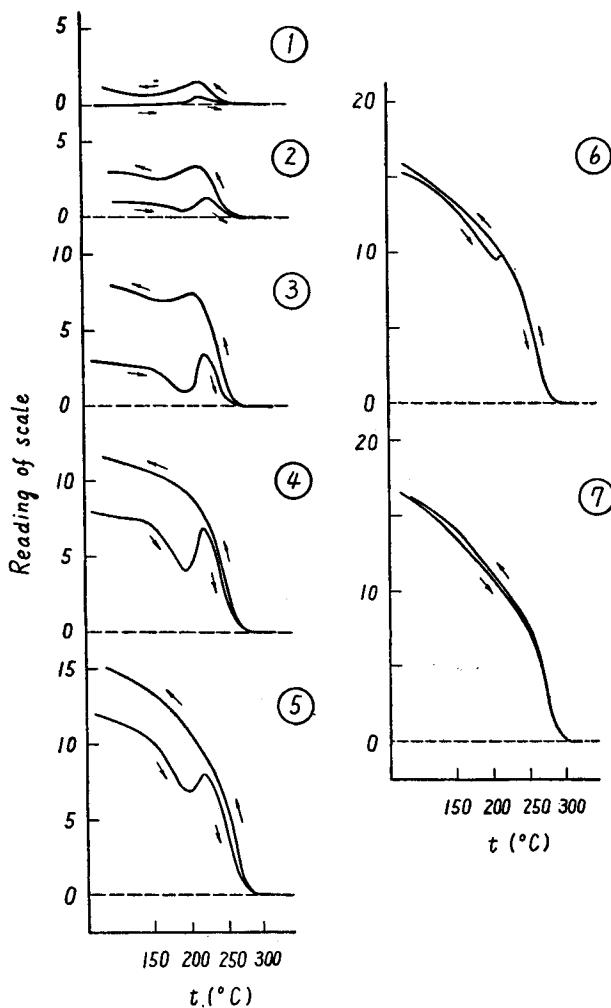

Fig. 12  
FeS<sub>1.09</sub> (decomp. product at 675°C)

its intensity of magnetization increases a little. On repeating the thermomagnetic analysis in vacuo of  $10^{-3}$  mmHg with the same sample, the intensity of magnetization increases gradually and it changes finally into ferromagnetic one whose Curie point is at  $295^{\circ}\text{C}$ . With this change into ferromagnetics, the hysteresis in the curve of thermomagnetic analysis disappears. In place of the repetition thus made, by maintaining the heat at  $320^{\circ}\text{C}$  for sixty minutes in vacuo, the sample changes immediately from antiferromagnetics to ferromagnetics. After this change is completed, repetition of heating and cooling does not causes the increment of the intensity of magnetization any more.

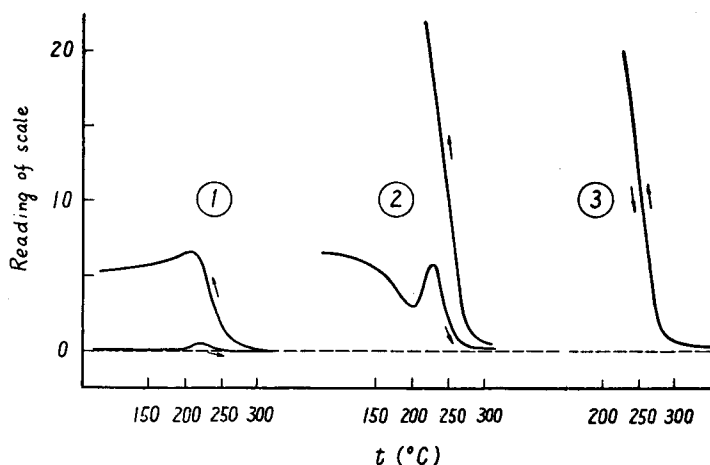

Fig. 13

$\text{FeS}_{1.08}$  (decomp. product at  $700^{\circ}\text{C}$ )  
(In each run, the sample was kept at  $320^{\circ}\text{C}$  for 60min.)

The same phenomenon as above was also observed with  $\text{FeS}_{1.08}$ . In Fig. 13, the result obtained of thermomagnetic analysis of  $\text{FeS}_{1.08}$  in vacuo of about  $10^{-3}$  mmHg is shown. In this run, the sample was kept at about  $320^{\circ}\text{C}$  for sixty minutes in every repetition.

- c)  $\text{FeS}_{1.06}$  (temperature of thermal decomposition;  $750^{\circ}\text{C}$ ),  $\text{FeS}_{1.05}$  (temperature of thermal decomposition;  $800^{\circ}\text{C}$ ) and  $\text{FeS}_{1.00}$  (temperature of thermal decomposition;  $900^{\circ}\text{C}$ )

Same as a) and b), the thermomagnetic analyses in vacuo of  $10^{-3}$  mmHg were made. The results obtained are summarized in Fig. 14. These samples ( $(1+x) \leq 1.06$ ) were found to be paramagnetic and the remarkable change in the

Table 2.

H. Haraldsen	Authors
$\text{FeS}_{1.14}$	$\text{FeS}_{1.13}$
} ferromagnetic	$\text{FeS}_{1.11}$
	} ferromagnetic
$\text{FeS}_{1.09}$	$\text{FeS}_{1.09}$
} antiferromagnetic	$\text{FeS}_{1.08}$
	} antiferromagnetic
$\text{FeS}_{1.06}$	$\text{FeS}_{1.06}$
} paramagnetic	$\text{FeS}_{1.05}$
	} paramagnetic
$\text{FeS}_{1.00}$	$\text{FeS}_{1.00}$

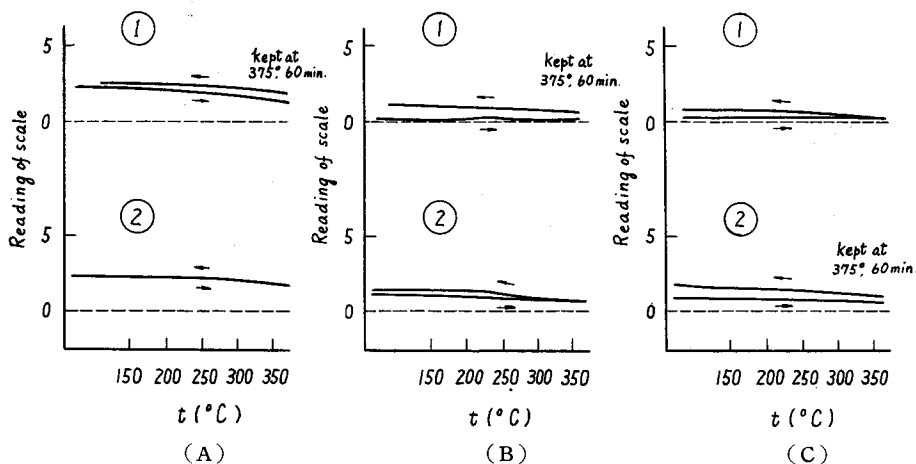

Fig. 14

- (A)  $\text{FeS}_{1.06}$  (decomp. product at  $750^{\circ}\text{C}$ )
- (B)  $\text{FeS}_{1.05}$  (decomp. product at  $800^{\circ}\text{C}$ )
- (C)  $\text{FeS}_{1.00}$  (decomp. product at  $900^{\circ}\text{C}$ )

intensity of magnetization as seen above was not observed.

As mentioned previously, the hysteresis was observed in the thermomagnetic analysis of various products of thermal decomposition. This hysteresis will be discussed in 3.4. Here, we compare the results of the thermomagnetic analysis made by us with the results obtained by H. Haraldsen.<sup>12)</sup> A fairly good coincidence was obtained in both measurements as shown in Table 2.

### 3.3. X-Ray Measurement of the Thermal Decomposition Products

Crystal structure of  $\text{FeS}_{1+x}$  belongs to the hexagonal system whose axial ratio is 1.66~1.68. Its lattice parameter and axial ratio have been measured by G. Hägg and I. Sucksdorff,<sup>14)</sup> H. Haraldsen<sup>12)</sup>

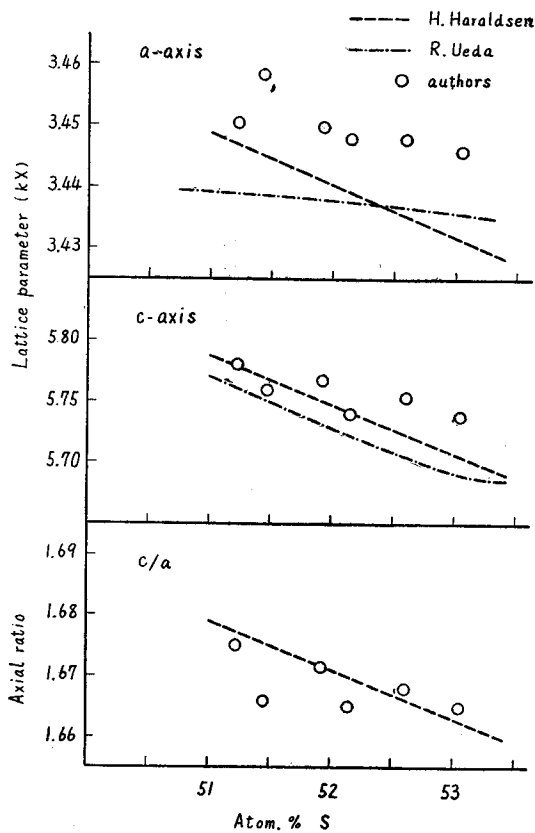

Fig. 15

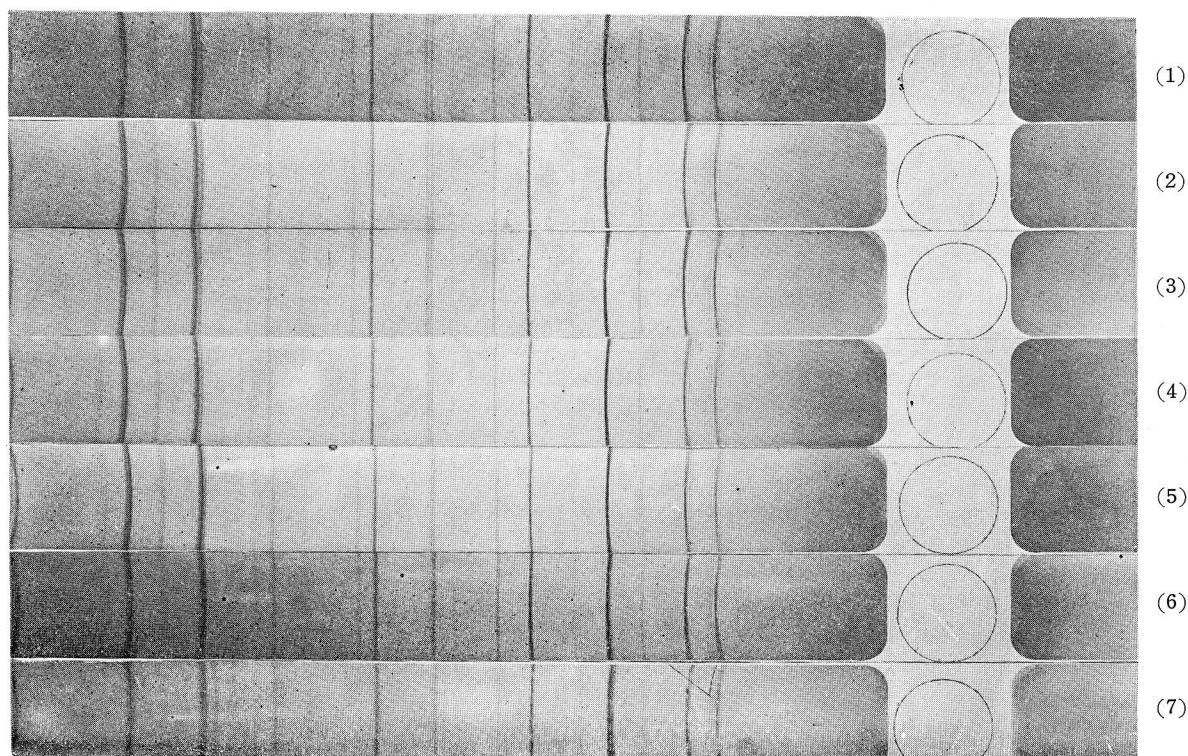

Photo. 1

(1)	FeS <sub>1.13</sub> ,	temperature of thermal decomposition	625°C
(2)	FeS <sub>1.11</sub> ,	"	650°C
(3)	FeS <sub>1.09</sub> ,	"	675°C
(4)	FeS <sub>1.08</sub> ,	"	700°C
(5)	FeS <sub>1.06</sub> ,	"	750°C
(6)	FeS <sub>1.05</sub> ,	"	800°C
(7)	FeS <sub>1.00</sub> ,	"	900°C

and R. Ueda.<sup>15)</sup> We obtained the X-ray diffraction patterns by the powder camera and calculated the lattice parameter  $a$ ,  $c$  and the axial ratio  $c/a$  by the ordinary method. These lattice parameter, axial ratio and X-ray photograms are shown in Fig. 15, and Photo. 1, respectively. From these figures, it is seen that the lattice parameter  $a$  and  $c$  decrease with an increase in the atomic percentage of sulphur, i.e., with an increase of the coefficient  $(1+x)$  in the formula of the products, and that the axial ratio decreases also by increasing the coefficient  $(1+x)$ .

#### 3.4. Some Investigations on the Change of Antiferromagnetic or Paramagnetic Samples to Ferromagnetic Ones

On the samples whose composition is between FeS<sub>1.00</sub> and FeS<sub>1.09</sub>, H. Haraldsen<sup>12)</sup> found, in the course of his study, that the reproducible results of measurement could

not be obtained if the preliminary heat treatment was not made. As described in 3.2, we found that the antiferromagnetic  $\text{FeS}_{1.09}$  or  $\text{FeS}_{1.08}$  changes into the ferromagnetic ones when the thermomagnetic analysis is repeated or the sample is kept at  $320^\circ\text{C}$  in vacuo.

The phenomenon that the paramagnetic or antiferromagnetic natural pyrrhotite changes into the ferromagnetic one by heating it to about  $300^\circ\text{C}$  was observed by many investigators. D. A. Kiskyras<sup>16)</sup> reported that the intensity of magnetization of natural pyrrhotite increased with the progress of weathering and that the paramagnetic pyrrhotite formed at high temperature changed into the ferromagnetic one when the thermomagnetic analysis was performed. T. N. Roze<sup>17)</sup> also found that the magnetic properties of pyrrhotite varied remarkably by heating. S. V. Lipin<sup>18)</sup> measured the thermomagnetic properties of six kinds of pyrrhotite mined in Russia and reported that the correlation between the intensity of magnetization and the sulphur content was not observed originally, but after heating them to  $280^\circ\text{C}$ , the intensity of magnetization was found to be proportional to the ratio S/Fe in the sample. He presumed the cause of this fact to be the homogenization of the crystal. T. Saito,<sup>19)</sup> also, observed the hysteresis in the curve of the thermomagnetic analysis of pyrrhotite.

On the artificial ferrous sulphide whose composition was about  $\text{FeS}_{1.08}$ , A. Michel et al<sup>20)</sup> reported, as shown in Fig. 16, that by quenching it from  $600^\circ\text{C}$ , the paramagnetic state, which was stable at high temperature, could be maintained at room temperature and by annealing, paramagnetic  $\text{FeS}_{1.08}$  changed easily into the stable ferromagnetic one, and that no difference in the

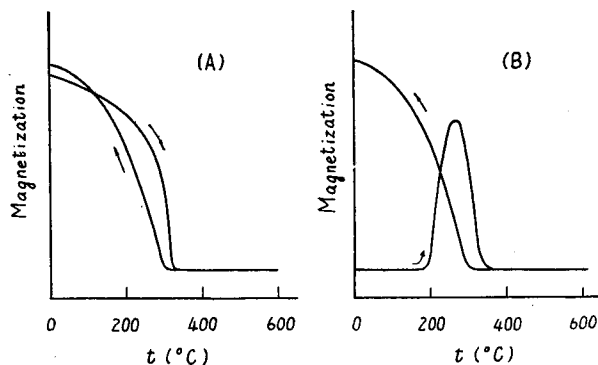

Fig. 16  
(A)  $\text{FeS}_{1.08}$  (annealed), (B)  $\text{FeS}_{1.08}$  (quenched from  $600^\circ\text{C}$ )  
(A. Michel et al; J. Phys. et Radium, 12, 189, (1951))

crystal structure in both states were observed. According to the view of A. Michel, the hysteresis which occurred in the thermomagnetic analysis of  $\text{FeS}_{1+x}$  may be explained by the change of the quenched state into the stable annealed ferromagnetic state by the heating in the thermomagnetic analysis.

The authors have paid special attention to the fact that the above-mentioned phenomenon of the change of magnetism by heating is remarkably affected by the conditions of the thermomagnetic analysis, above all, by the atmosphere surrounding the sample, and pursued further into the investigation on this point.

a) Investigations on  $\text{FeS}_{1.09}$

$\text{FeS}_{1.09}$  prepared by the thermal decomposition of pyrite as described above was put into a silica capsule which was evacuated by a rotary pump and then sealed off and was analysed. The results obtained of the thermomagnetic analysis are shown in Fig. 17. The sample thus sealed in the evacuated silica capsule does not change into ferromagnetics as shown in the figure. That is, by the first run, the intensity of magnetization increases a little, but thereafter the repetition of heating and cooling or the maintenance of the heat at  $300^\circ\text{C}$  does not affect any more on its thermomagnetic properties.

The sample, whose increment of the intensity of magnetization had finished after the thermomagnetic analysis of Fig. 17, was taken out of the silica capsule and was analysed again in vacuo of  $10^{-3}$  mm

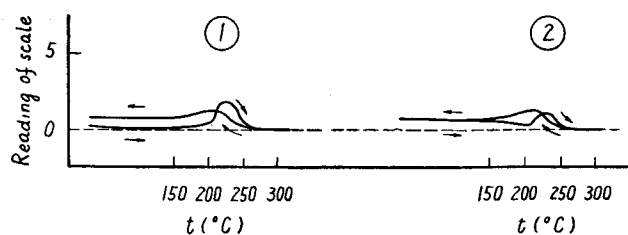

Fig. 17

(In each run, the sample was kept at  $330^\circ\text{C}$  for 60 min.)

Hg. In this measurement, the intensity of magnetization increases, as shown in Fig. 18, to that of the ferromagnetic one which shows no hysteresis.

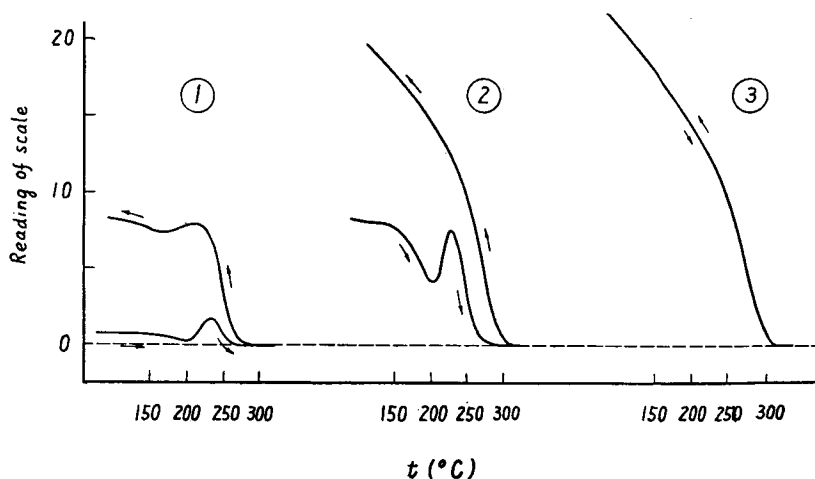

Fig. 18

(In each run, the sample was kept at  $320^\circ\text{C}$ , for 60 min.)

Thermomagnetic analysis of  $\text{FeS}_{1.09}$  was made in vacuo of  $5 \times 10^{-5}$  mmHg and the results shown in Fig. 19 were obtained. It was found that no increment in the intensity of magnetization was observed by the repetition of heating and cooling or by maintaining it at  $320^\circ\text{C}$ . The antiferromagnetic state of the sample was retained.



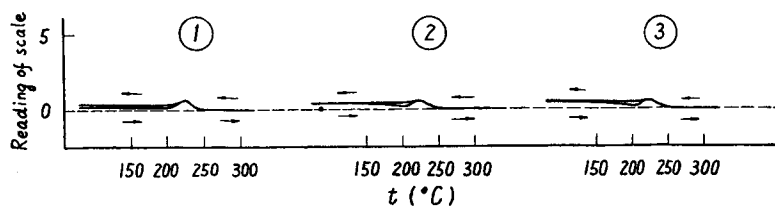

Fig. 19

(In each run, the sample was kept at 320°C for 60 min.)

The result of thermomagnetic analysis made in the air is shown in Fig. 20. In this run, the temperature of the maximum intensity of magnetization in heating ( $\gamma$ -maximum) was the same as that observed in vacuo, and by the analysis the sample changed into ferromagnetics.

From the above-mentioned results of investigations, it may be said that the change of antiferromagnetic  $\text{FeS}_{1.09}$  into the ferromagnetic one depends on the degree of vacuum in the apparatus, and it remains unchanged stably in the analysis in high vacuum and it changes into the ferromagnetic one whose Curie point is 295°C in the analysis in low vacuum or in the air. Furthermore, from the fact

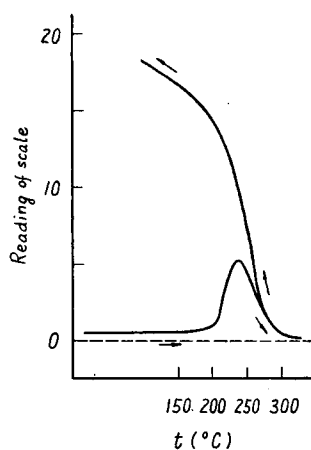

Fig. 20

that this change proceeds more rapidly in the air than in the vacuum and it scarcely occurs with the sample put in the evacuated silica capsule, it is considered that this change is dependent on the partial pressure of oxygen which contacts with the sample.

**b) Investigations on  $\text{FeS}_{1.08}$**

The results obtained of the thermomagnetic analyses made with the sample in the evacuated silica capsule are shown in Fig. 21. After the analysis, the sample was taken out of the silica capsule, and with it, thermomagnetic analysis was made

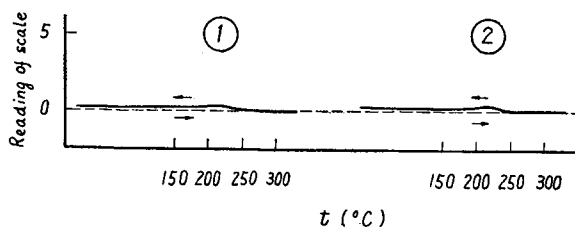

Fig. 21

(In each run, the sample was kept at 330°C for 60 min.)

in vacuo of  $10^{-3}$  mmHg, the results of which are shown in Fig. 22. From these figures, we found that the similar behavior, as in a), was also observed with  $\text{FeS}_{1.08}$  and that, in this case, the change to ferromagnetics was not so easy as in the case of  $\text{FeS}_{1.09}$ .

c) Investigations on

$\text{FeS}_{1.06}$ ,  $\text{FeS}_{1.05}$  and  $\text{FeS}_{1.00}$

These thermal decomposition products are paramagnetic as described in 3.2

c), and their intensity of magnetization was found to remain unchanged by heating them to  $500^\circ\text{C}$  in vacuo or to  $300^\circ\text{C}$  in the air. Thermomagnetic analyses of these samples were made in the air, raising the maximum temperature of the analyses up to  $430^\circ\text{C}$  where ferrous sulphide commences barely to be oxidized. In certain runs the sample was held for thirty to sixty minutes at this temperature. The measurements were repeated with the same sample for several times.

Fig. 23 shows the results obtained with  $\text{FeS}_{1.06}$ . In this run, the measurement was repeated twice. It was found by this analysis, that paramagnetic  $\text{FeS}_{1.06}$  changed to the ferromagnetic one whose Curie point is  $295^\circ\text{C}$ . Similar behavior in the analysis

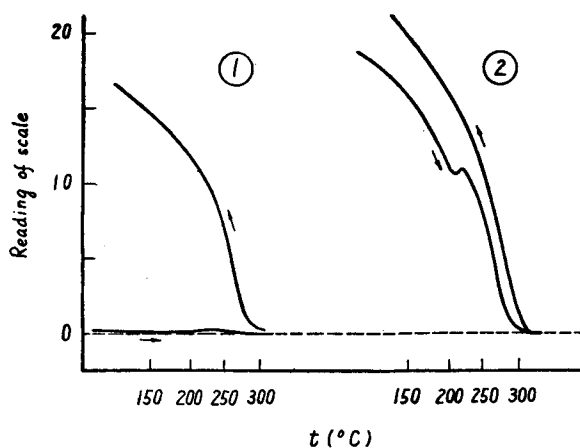

Fig. 22

(In each run, the sample was kept at  $320^\circ\text{C}$  for 60 min.)

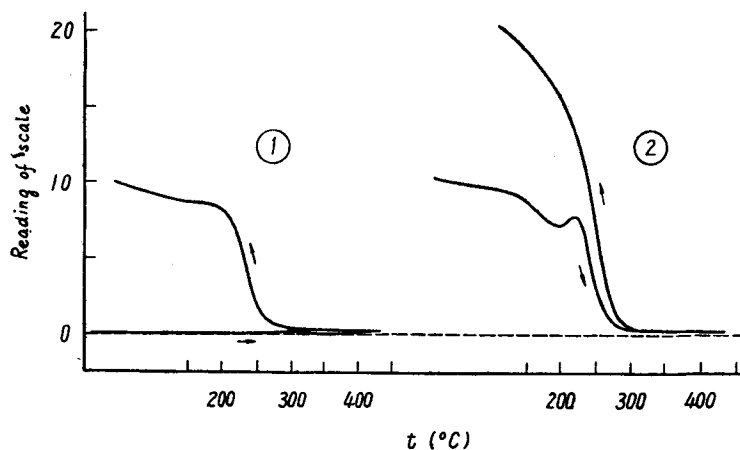

Fig. 23

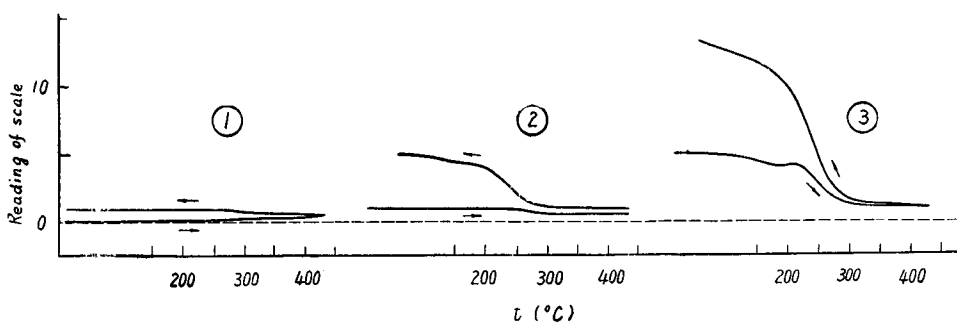

Fig. 24  
(In 2nd and 3rd run, the sample was kept at 430°C for 30 min.)

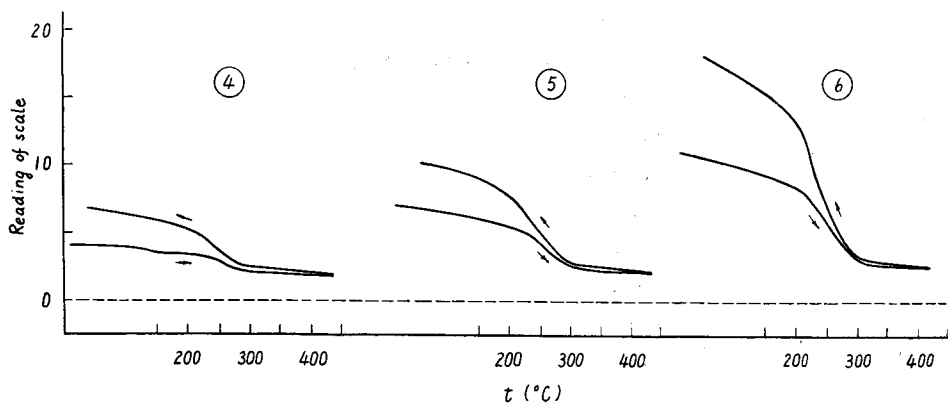
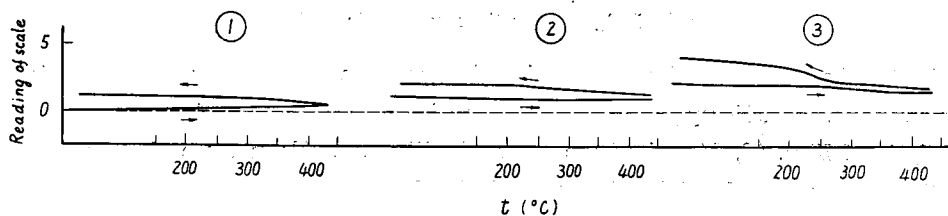

Fig. 25  
(In every run except first one, the sample was kept at 450°C for 30 min.)

was observed with  $\text{FeS}_{1.05}$ , and it changed to the ferromagnetic one by three repetitions of heating and cooling as shown in Fig. 24. However, the rate of increment of the intensity of magnetization of this sample seems to be duller than that of  $\text{FeS}_{1.06}$ .

In the case of  $\text{FeS}_{1.00}$ , also, a similar change into the ferromagnetic one was observed (Fig. 25).

In Figs. 23, 24 and 25, it was observed that the intensity of magnetization at above Curie point does not decrease to zero, but it retains a certain value. This

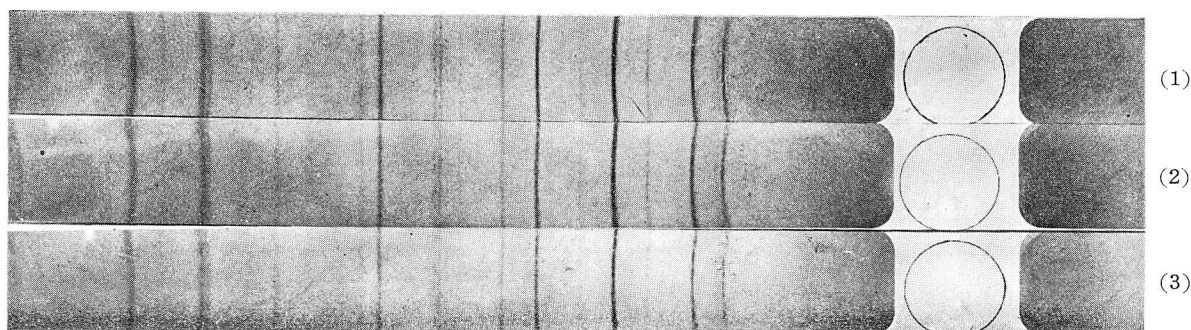

Photo. 2

- (1)  $\text{FeS}_{1.06}$ , after thermomagnetic analysis
- (2)  $\text{FeS}_{1.05}$ , after thermomagnetic analysis
- (3)  $\text{FeS}_{1.00}$ , after thermomagnetic analysis

indicates the formation of a compound which possesses its Curie point at a higher temperature. The X-ray powder photograms of the samples after the thermomagnetic analysis of Figs. 23, 24 and 25 are shown in Photo. 2. From these photograms, the lattice parameter and axial ratio were calculated as follows;

$$a = 3.448 \text{ kX}, \quad c = 5.734 \text{ kX} \text{ and } c/a = 1.66.$$

Comparing these values with to those obtained in 3.3, we may conclude that paramagnetic  $\text{FeS}_{1+x}$  changes into ferromagnetic  $\text{FeS}_{1+x}$  whose sulphur content is higher. Very weak diffraction lines of  $\text{Fe}_3\text{O}_4$  were detected by the naked eyes in the photograph of  $\text{FeS}_{1.00}$  after the thermomagnetic analysis (Photo. 2). From these facts, the following discussion may be given.

Antiferromagnetic or paramagnetic  $\text{FeS}_{1+x}$ , whose coefficient of formula,  $(1+x)$ , is less than 1.09, is stable in vacuo of  $5 \times 10^{-5}$  mmHg, but its intensity of magnetization increases by the repetition of heating and cooling in vacuo of  $10^{-3}$  mmHg or in the air, and it changes finally into ferromagnetic  $\text{FeS}_{1+x}$  whose Curie point is at  $295^\circ\text{C}$ . By this change, a new ferromagnetic compound, whose Curie point lies at a higher temperature, is formed. This compound is identified as  $\text{Fe}_3\text{O}_4$  by X-ray measurement. The rate of this change of antiferromagnetic or paramagnetic  $\text{FeS}_{1+x}$  into ferromagnetic  $\text{FeS}_{1+x}$  has a bearing upon the partial pressure of oxygen of the atmosphere, the maximum temperature of heating and the time of maintenance at this temperature.

Therefore, this phenomenon may be considered to depend, not on the effect of quenching and annealing as described by A. Michel,<sup>20)</sup> but on the initial stage of oxidation of  $\text{FeS}_{1+x}$ .

The fact that ferrous sulphide,  $\text{FeS}$ , changes into  $\text{FeS}_{1+x}$  in the initial stage of its oxidation was found by K. Niwa et al.<sup>21)</sup> and P. G. Thornhill and L. M. Pidgeon<sup>22)</sup>. From our results of study, it was found that  $\text{FeS}_{1+x}$  ( $(1+x) \leq 1.09$ ) also changes, in

the initial stage of oxidation, into ferromagnetic  $\text{FeS}_{1+x}$  ( $(1+x) \geq 1.11$ ) whose composition is near the upper limit of solubility of sulphur. Because  $\text{Fe}_3\text{O}_4$  is formed by this change, the equation of reaction, which occurs in this initial stage of oxidation, can be written as follows;

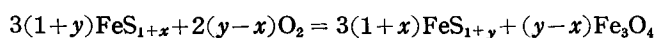

where  $0 \leq x \leq 0.09$  and  $0.11 \leq y \leq 0.13$ .

#### 4. Summary

Studies were performed on the kinetics of thermal decomposition of pyrite and on the properties of thermal decomposition products by the method of thermobalance, thermomagnetic analysis and X-ray. The results obtained are summarized as follows:

1. On the assumption that the rate of thermal decomposition of pyrite in the atmosphere of nitrogen between 625° and 900°C is followed by the first order reaction, the negative logarithms of the mol fraction of pyrite,  $-\log x$ , were plotted against the reaction time  $t$ . Straight lines were not obtained but the lines were composed of two parts of straight lines whose intersections lie at  $x \approx 0.3$ . From the linear parts before and after this knick point, the rate constants of thermal decomposition in the initial period ( $k_{1i}$ ) and in the final period ( $k_{1f}$ ) were calculated. From these rate constants, an activation energy of 50.9 kcal is obtained for the initial period of the reaction and 40.3 kcal for the final period of the reaction.

2. The composition of the thermal decomposition products is not stoichiometric, but it varies with the temperature of decomposition. In general, it can be represented as  $\text{FeS}_{1+x}$ . The coefficient of the formula decreases with an increase of the temperature of decomposition. They are considered to be the homogeneous solid solution of iron and sulphur.

3. Of these thermal decomposition products,  $\text{FeS}_{1.13}$  (decomp. temp.; 625°C) and  $\text{FeS}_{1.11}$  (decomp. temp.; 650°C) are ferromagnetic and its ferromagnetic Curie point was found at 295°C;  $\text{FeS}_{1.09}$  (decomp. temp.; 675°C) and  $\text{FeS}_{1.08}$  (decomp. temp.; 700°C) are antiferromagnetic and its antiferromagnetic Curie point was found at about 220°C;  $\text{FeS}_{1.06}$  (decomp. temp.; 750°C),  $\text{FeS}_{1.05}$  (decomp. temp.; 800°C) and  $\text{FeS}_{1.00}$  (decomp. temp.; 900°C) are paramagnetic. The crystal structure of these  $\text{FeS}_{1+x}$  belongs to the hexagonal system whose axial ratio  $c/a$  is 1.66~1.68. Lattice parameter  $a$ ,  $c$  and axial ratio  $c/a$  decrease by increasing the content of sulphur in  $\text{FeS}_{1+x}$ . These results coincide with those of H. Haraldsen.

4. When antiferromagnetic or paramagnetic decomposition products are heated, their thermomagnetic properties change depending upon the heating conditions, such as oxygen partial pressure of the atmosphere, heating temperature, etc.; that is, the

thermomagnetic properties of antiferromagnetic samples remain unchanged when they are heated to about 300°C in vacuum sealed silica capsule or in vacuo of  $5 \times 10^{-5}$  mmHg, however, when they are heated to the same temperature in vacuo of about  $10^{-3}$  mm Hg or in the air, it changes to the ferromagnetic one whose Curie point is 295°C. The paramagnetic samples change also to the ferromagnetic ones, and the formation of small amount of  $\text{Fe}_3\text{O}_4$  was detected by X-ray when they are heated in the air to about 430°C. By this change, the lattice parameter and axial ratio of  $\text{FeS}_{1+x}$  change to those of ferromagnetic one. From these results, it may be concluded that such changes from antiferromagnetics or paramagnetics to ferromagnetics is due to the initial stage of oxidation of  $\text{FeS}_{1+x}$ , and that at this initial stage of oxidation, paramagnetic or antiferromagnetic  $\text{FeS}_{1+x}$  changes into ferromagnetic  $\text{FeS}_{1+x}$  whose composition is near the upper limit of solubility of sulphur in  $\text{FeS}_{1+x}$ .

This study was conducted with the financial support by the Ministry of Education for which the authors wish to express their hearty gratitude.

#### References

- 1) H. Tohata, J. Sulphuric Acid Assoc. of Japan, **3**, 378, (1950).
- 2) M. Kameda et al, J. Min. Inst. of Japan, **68**, 71, (1952).
- 3) K. Niwa et al, J. Japan Inst. of Metals, **18**, 1, (1954).
- 4) G.-M. Schwab and J. Philinis, Z. anorg. Chem., **253**, 71, (1945), J. Am. Chem. Soc., **69**, 2588, (1947).
- 5) Y. Ogawa, "Fundamentals of Non-Ferrous Metallurgy", (Hitetsu Seiren no Kiso), **15**, (1952).
- 6) J. N. Ong et al, J. of Metals, **8**, Tr. AIME 257, (1956).
- 7) S. Yagi et al, J. Sulphuric Acid Assoc. of Japan, **4**, 83, (1951), J. of Soc. of Chem. Ind., Japan, **56**, 131, (1953).
- 8) R. Juza and W. Biltz, Z. anorg. u. allg. Chem., **205**, 273, (1932).
- 9) R. W. Selwood, "Magnetochemistry", Interscience Pub., **11**, (1956).
- 10) e. g., G.-M. Schwab and A. Karatzas, Kolloid Z., **106**, 128, (1944).
- 11) G. Gallo, Ann. chim. applicata, **17**, 39, (1927).
- 12) H. Haraldsen, Z. anorg. u. allg. Chem., **231**, 78, (1937), *ibid.*, **246**, 169, 195, (1941).
- 13) R. Benoit, Compt. rend., **234**, 2174, (1952).
- 14) G. Hägg and I. Sucksdorff, Z. phys. Chem., **B22**, 444, (1933).
- 15) R. Ueda, Busseiron Kenkyu, **33**, 55, (1950, Dec.)
- 16) D. A. Kiskyras, Beitr. angew. Geophys., **10**, 308, (1943).  
Neues Jahrb. Mineral. Abhandl., **80A**, 297, (1950).
- 17) T. N. Roze, Uchenye Zapiski Leningrad Cosdarst. Univ., No. 120, Ser. Fiz. Nauk., No. 7, **174**, (1949), C. A., **46**, 6559, (1952).
- 18) S. V. Lipin, Zapiski Vsesoyuz. Mineral. Obschetva, **80**, 258, (1951), C. A., **46**, 3342, (1952).
- 19) T. Saito, Bull. of the Geol. Survey of Japan, **7**, 39 (1956).
- 20) A. Michel, G. Chaudron and J. Benard, J. Phys. et Radium, **12**, 189, (1951).
- 21) K. Niwa et al, Bull. Chem. Soc. of Japan, **29**, 100, (1956), J. of Metals, **9**, Tr. AIME 269, (1957).
- 22) P. G. Thornhill and L. M. Pidgeon, J. of Metals, **9**, Tr. AIME 989, (1957).