

Weathering of the Granite Soils and Its Influence on the Stability of Slope

By

Shin-ichiro MATSUO*, Kazuhiko NISHIDA** and Shinpei YAMASHITA***

(Received December 26, 1967)

The cutting slopes in granite soil regions are exposed in air and subjected to temperature change and water infiltration immediately after cutting. Then the strength of the soil mass is lowered successively up to failure point. In order to clarify the cause of the phenomena, the authors tried to examine a slope selected in a granite soil region by means of physical, chemical and mineralogical analysis.

According to the results obtained from the above experiments, it is concluded that the original ground before cutting can be classified into three zones with characteristic clay minerals and the more the ground is weathered initially, the more rapidly their strength decreases excepting for the severely weathered part.

These results are considered to depend largely on the fact that the soil grains weathered originally in the long period of time are relatively sensitive or unstable to chemical and mechanical actions.

1. Introduction

The cutting slopes in granite soil regions are exposed in air and subjected to alternative temperature change, leaching out of elements by means of rain water infiltration immediate after cutting. Consequently the strength of the soil mass is lowered successively up to the point of failure.

Concerning these phenomena occurring on the surface of the slope, it is important to know how the slope had been weathered and altered during the long period of time. The process of mechanical and chemical alteration occurred in the course of weathering during a long period of time differs depending on the characteristics of the parent rock, topography and geohistry¹⁾. In any case, when the weathered granite soil region is cut out, stability of the slope depends on the previous condition of weathering.

S.S. Goldich²⁾ (1938) studies on the weathering products of gneiss by means of

* Department of Civil Engineering

** Department of Civil Engineering, Training Institute for Engineering Teachers

*** Department of Civil Engineering Faculty of Engineering Ehime University.

chemical and mineralogical analysis reported that main part of weathering products consists of kaolin group minerals which are secondary products from feldspar and the elements such as Na, Ca, Mg are leached in process of weathering. Kanno and others³⁾ (1957) who studied weathering of granite soils reported that clay minerals such as kaolinite, halloysite, illite, vermiculite, gibbsite are identified in the finer particles of the soil.

On the other hand, Saito⁴⁾ (1956) stated that the cause of weathering of granite is not chemical but physical and mechanical alteration.

According to the results described above, it is evident that chemical, mineralogical and physical alteration must be considered in regard to the weathering of the granite rocks. These alterations enough to produce secondary minerals must require a long time. Then, the problems in engineering projects seem to be of a relatively short time alteration.

D.F. Griggs⁵⁾ (1925) from experimental study on specimen of fresh granite under an alternative temperature condition had concluded that the water condition more affects the alteration of rock texture than the temperature condition. In order to make clear how the phenomena are done during a relatively short time and how it affects the soil properties, the authors have carried out experimental studies in the field and in the laboratory on the samples brought from a slope at Mt. Hiei, Kyoto prefecture.

2. Samples

2-1 On the slope surveyed

The locality of the slope having been cut down about three years before was selected for study in biotite granite region which had intruded into the paleozoic formation. On the slope, the degree of weathering was observed to be changed successively and homogeneously from the lower fresh rock part to the upper severely weathered part. Even in the upper most part, the soil mass can be distinguished clearly from the top soils in that the weathered granite soil part remains an original rock structure. The lowest part, even if the porosity increased, shows the original black colour of biotite. In the part between the middle to the upper most part, biotite and soil mass are coloured brownish and feldspar can be crushed away with the finger.

According to these characters based on observation, the slope can be classified into several stages of weathering.

2-2 Sampling site

On the slope shown in Fig.-1, the sampling points No. 1 through No. 6 were

selected from the upper to the lower part at intervals about one meter and samples were taken from the depths of 0, 5, 10, 15, and 20 cm in the vertical direction from the surface points selected.

The samples, if possible, were collected in an undisturbed state and sealed by paraffin for the measurement of density, water content and leaching test. The other part of the samples collected in disturbed state were used for chemical, grain size classification and X-ray analysis.

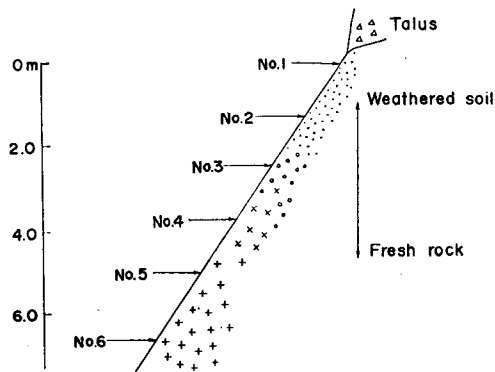

Fig. 1. Section of the Cutting Slope and Sampling Site

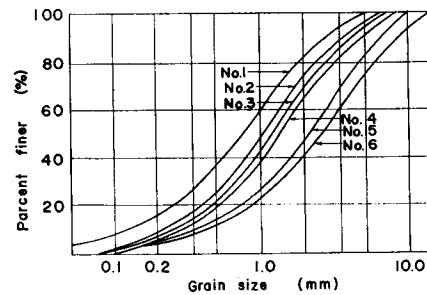

Fig. 2. Grain Size Distribution on the Surface of the Slope.

3. Physical and Chemical Properties

3-1. Grain size Classifications

Grain size analysis was done as careful as possible not to crush the original grain structure. The results are shown in Fig.-2. Though these results are of only on the surface of the slope, the same properties were obtained in vertical direction. But its variation is found to be the largest at point No. 2.

3-2. Water Content, Dry density and Specific Gravity of Soil Grains

The results measured are given in Fig.-3. Dry density decreases gradually from the lower part to the upper part, water content increases slightly toward the upper part and becomes largest at point No. 1. The Specific gravity of the soil grains remains almost constant throughout the slope.

Consequently the weathering degree is expressed distinctly in density.

3-3. Distribution of Clay Minerals

All the samples collected were separated by a sedimentation method in water, so that the samples became $0.3-1 \mu$ in size, then the samples were condensed with a centrifuge. After that, the samples were dried for three hours in 110°C deccater.

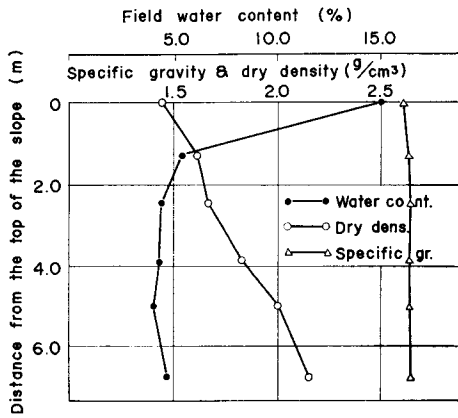

Fig. 3. Physical Properties of the Soils on the Surface of the Slope.

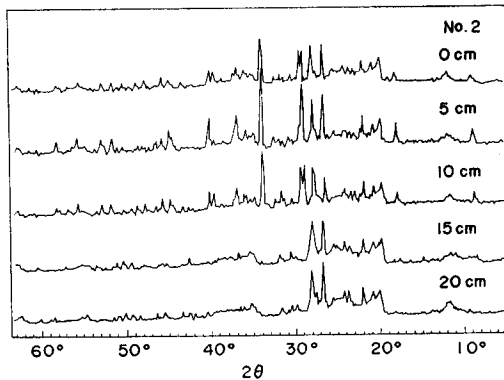

Fig. 4. X-ray Spectrograph.

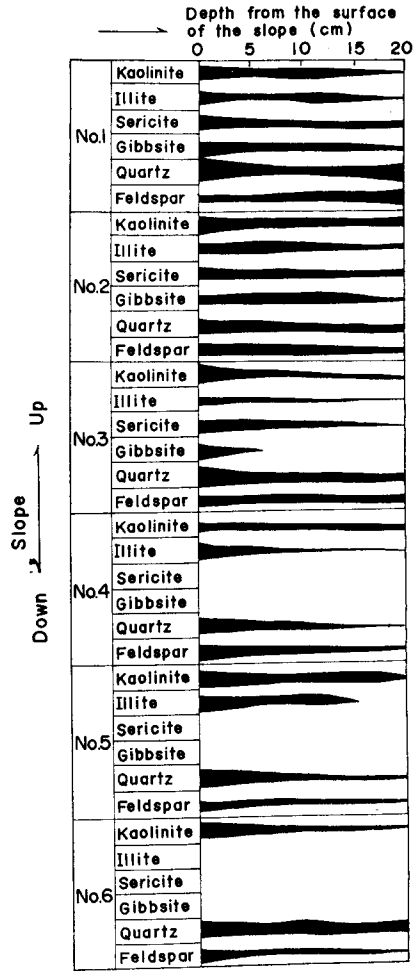

Fig. 5. Clay Minerals on the Each Point.

The samples thus prepared were examined by means of an X-ray diffraction apparatus (DZ-24 Type, $\text{Cu } \lambda = 1.5405 \text{ \AA}$) which was produced from Shimazu Co, Ltd. Fig. 4 shows an example of the results. Detailed method of identification is abbreviated for simplicity.

The quantitative analysis of clay minerals only by means of X-ray analysis is considered to be difficult today. Then, expressing the relative quantity of given minerals by the height of the peak which appeared on the X-ray spectrograph, the kinds and quantity of clay minerals are shown in Fig.-5.

Following the figure, the primary products of weathering are only quartz and feldspar and the secondarily altered minerals are kaolin minerals (kaolinite,

halloysite), illite, sericite and gibbsite. The above results tell that more kinds of clay minerals are found in the upper part than the lower part of the slope, Illite occurs at point No. 5 to No. 1, whereas sericite and gibbsite are recognized at point No. 1 to No. 3. At the lowest point No. 6 only kaolin minerals are found.

Therefore, weathered soil slope before cutting can be classified with characteristic clay minerals as follows;

1. Gibbsite Zone (No. 1 to No. 3)
2. Illite Zone (No. 3 to No. 5)
3. Kaolin Zone (No. 5 to No. 6)

The abundant quantity of primary minerals in the upper most part indicates that quartz and feldspar are crushed into more finer particles than the other part. The height of the peak in X-ray spectrograph is said to be affected not only by quantity but also the degree of crystallinity of clay minerals.

Therefore the height of the peak does not show absolute quantity. The kaolin minerals in the upper most part are found to be almost the same quantity as that of the lower most part. This fact means that fine quartz grains included in constant volume of examined samples are more abundant than kaolin minerals, so the quantity of the kaolin minerals is not always small in the upper part of the slope. If alteration undergone after cutting can be regarded as vertical change from slope surface, in general, an increase of quartz toward the surface of the slope is significant especially at point No. 1, even if feldspar decreases. Kaolin at No. 1, No. 2 and No. 3 shows an increase toward the surface, however, at point No. 4 and No. 5 it remains constant or slightly increases. Gibbsite increases toward the surface, illite also, not remarkably, shows an increase.

According to the facts, the weathering process of the soils before cutting is represented clearly in the species of clay minerals but alteration after cutting is not so remarkable as the former case and the kaolin group minerals, gibbsite, and illite increase slightly toward the surface of the slope. The alteration after cutting is considered to be the largest in the portion of the most severely weathered before cutting.

3-4. Variation of Chemical Compositions

Chemical analysis of the principal constituents of the samples was carried out. The results are shown in Fig.-6. The method adopted was fusing with sodium carbonate for silica and flamespectrophotometer for the other elements. Fig. 6 indicates that Na, Ca, Fe decrease generally from the lower part to the upper part of the slope, while SiO₂ alone remains constant or shows a somewhat increase.

In the vertical direction to the surface, Na, Ca, Fe decrease but SiO₂ increases

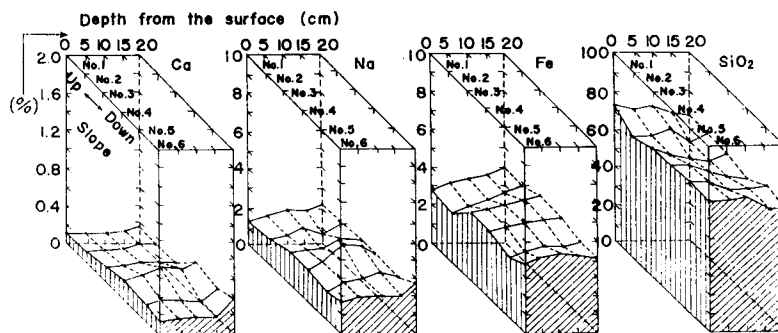

Fig. 6. Chemical compositions.

slightly toward the surface of the slope. These facts suggest that weathering of the slope before cutting can be ascribed to the chemical action of CO_2 and H_2O on the solution of the other acid or alkaline substance, by which the formation of clay minerals is accelerated. In other words, mechanical decomposition and chemical alteration of feldspar and biotite cause dissociation of Fe, Ca, Na ions.

The alteration toward vertical direction which is regarded as change after cutting is also thought to be the same process as the case above described, but differs considerably in that these ions are liberated more rapidly than the former case. Because unstable ions remaining between or around the soil fragments due to weathering of the long period of time can be easily and rapidly leached out by infiltration of rain water.

SiO_2 increases apparently toward the surface because of the decrease of the other elements.

In comparison with the chemical composition of the rock forming minerals and clay minerals, orthoclase ($\text{K}_2\text{O} \cdot \text{Al}_2\text{O}_3 \cdot 6\text{SiO}_2$), plagioclase ($\text{Na}_2\text{O} \cdot \text{Al}_2\text{O}_3 \cdot 6\text{SiO}_2 - \text{CaO} \cdot \text{Al}_2\text{O}_3 \cdot 2\text{SiO}_2$) are altered into kaolinite ($\text{Al}_2\text{O}_3 \cdot 2\text{SiO}_2 \cdot 2\text{H}_2\text{O}$) gibbsite ($\text{Al}_2(\text{OH})_3$). In this process, Ca, K, Na elements are dissociated and on the contrary, Al_2O_3 , SiO_2 rich minerals increase.

3-5. Field Shear Test

In order to find out the effects of these alterations on the strength of the soil slope, the field shear test was carried out by means of following apparatus. Generally, the weathered granite soils are easily broken even with a slight shock, therefore, collection of undisturbed samples is almost impossible with the usual method. To compare with the data obtained before, the field test was supposed to be better than the laboratory test on the disturbed samples. The method and apparatus used are as follows; a steel plate of about 80 cm^2 area was placed upon the slope surface, then steel nails were penetrated through the opening on the edge of the

plate into soils up to 2 cm depth. The inside part of the plate was confined by the nails and vertical stress on the plate was applied taking advantage of the reaction of anchor fixed apart. The apparent internal angle of friction (ϕ) and cohesion (C) were measured by the same procedure and analysis as direct shear test prevailed.

The results are shown in Fig.-7. According to the results, ϕ increases uniformly from the upper part to the lower part of the slope. These facts, as described in Fig.-2, -3 must be caused due to disintegration of soil grains and reduction of the density of the soil mass. C decreases gradually from the lower part toward the upper part of the slope No. 2 where it is found to be minimum and increases again at the upper most part No. 1.

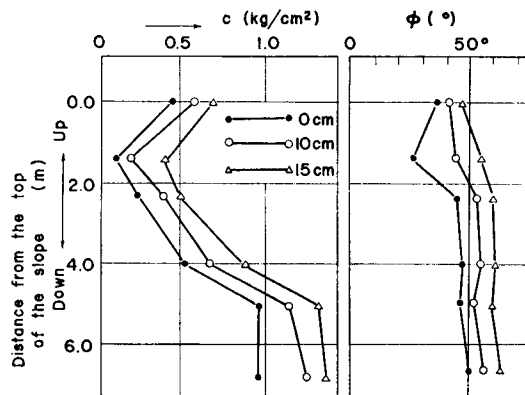

Fig. 7. Results from the Field Shear Test.

Concerning the reason of the facts, the cohesive strength of the lower part from point No. 2 to No. 6 is regarded to be furnished by the original bonding energy between atoms spaced in crystal lattice and variation of strength is due to the difference in adhesive power of ions of various kinds which are reduced by the action of water containing CO_2 and other substances. In another words, the affinity of crystal atoms would weaken when the crystal lattice becomes loose in the process of weathering and the atoms would break away from the crystal lattice. However a part of the ions such as Fe, Si, Mg, Na and OH remain adhered to the surface or void between the soil fractions.

For the reason of the increase of C at No. 1, the cohesion of the part is considered to be varied due to the water content as fine grained soils but detailed mechanism of the phenomenon is the problem to be examined further.

According to the variation for vertical direction, both ϕ and C decrease generally toward the surface of the slope, and the greatest variation is found at point

No. 2 which means that this part is the most unstable portion for weathering after cutting. A somewhat smaller degree of variation at the most upper point No. 1 indicates that the part was too much weathered to be altered further after cutting. The tendency of decrease of cohesion toward the surface of the slope is regarded to be affected much more by an increment of porosity and leaching of ions than the alteration or argillization of soil fragments.

3-6. Leaching Test

To prove the facts mentioned above experimentally, the samples being hardly treated (No. 5) were placed into the permeability test cell of diameter 6 cm and length 5 cm. The space between the cell and sample was filled with paraffin, then water containing CO_2 was infiltrated into the sample. The direct shear test was made on the sample infiltrated with CO_2 containing water of 100, 200, -600 cc respectively. When the vertical stress of 0.4 Kg/cm^2 was applied, shear strength at failure was measured.

The results are given in Fig.-8, -9. Fig.-9 shows the volume of elements leached out of the samples into the infiltrated water.

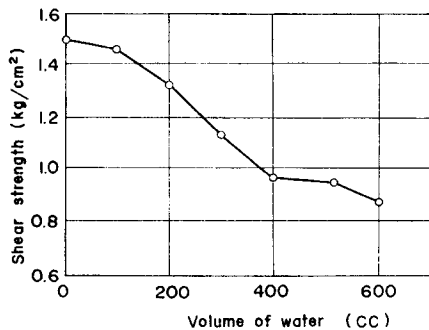

Fig. 8. Volume of Infiltrated Water and Shear Strength.

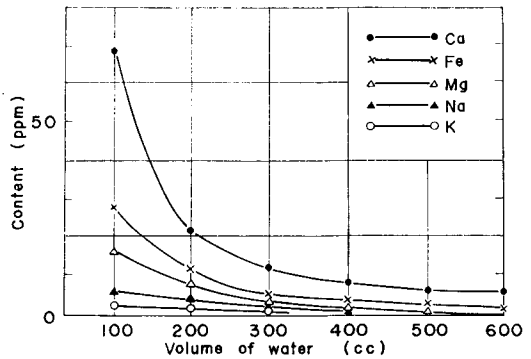

Fig. 9. Volume of Infiltrated Water and Leached Elements.

Following the results, the leaching of Ca ion is the most remarkable, and the amount becomes smaller in the order of Fe, Mg, Na. The reduction curve of strength agrees relatively well with the volume of the leaching elements.

4. Summary and Conclusion

The results obtained are summarized as follows;

- 1) The weathered residual soils from granite rocks are found to be originated in the process that the density of the soil mass decreases and soil fractions become

finer and finer with the increment of field water content but specific gravity of grains remains almost unchanged.

Therefore, the dry density can be a useful criterion for measuring the degree of weathering.

2) When the granite soil region is cut out, the degree of alteration after cutting is affected considerably by the weathering degree of the ground before cutting. The weathering degree before cutting is expressed as an increase of clay minerals, whereas alteration after cutting is regarded as a variation of the quantity of the clay minerals and crushing of primary minerals.

The slope can be classified depending on the characteristic clay minerals into three zones such as gibbsite zone, illite zone and kaolin zone from the upper part to lower part. Generally speaking, remarkable alteration after cutting is found at the point where the weathering before cutting has very far progressed except for the extremely weathered portion.

3) In the process of weathering before cutting, such elements as Fe, Ca, Na are dissociated. The same process is supposed in alteration after cutting but it is somewhat more remarkable than the former. This fact indicates that the residual ions remaining around the soil particles are leached rapidly out suffering from severe rain water infiltration immediately after cutting.

4) The strength properties on the soil slope correspond well to the degree of weathering, and the properties of before cutting affect that of after cutting. The severely weathered zone, where a smaller degree of alteration after cutting is observed, is considered to correspond to the point where the soil has been too much weathered to be altered further.

5) The leaching phenomena of residual ions around the soil particles become one of the causes of relatively rapid reduction of the soil strength.

References

- 1) Matsuo, S., K. Nishida and S. Yamashita; Relation between Granitic Rock Weathering and Topography and Rock Texture, Abstract of the Conference of Kansai Branch of Japan Society of Civil Engineers, (1965) in Japanese
- 2) Goldich S.S.; A Study in Rock Weathering, Jour. Geol. Vol. 46, pp. 17-58 (1938)
- 3) Kano, I. and Others; On the Clay Minerals Found in Reddish Yellow Soils Originated from Granitic Rocks, II., Soil and Fertilizer, Vol. 28, No. 2, pp. 13-15 (1957) in Japanese
- 4) Saito, M.; Weathering from Granite to Masa, Soil and Foundation, Vol. 4, No. 3, pp. 22-23 (1956) in Japanese
- 5) Griggs, D.F.; The Factor of Fatigue in Rock Exfoliation, Jour. Geol. Vol. 44, pp. 783-796 (1936)
- 6) Matsuo, S., K. Nishida and S. Yamashita; Weathering of the Granitic Soils and Its Influence on Stability of the Slope; Abstract of 21th Conference of Japan Society of Civil Engineers (1966) in Japanese
- 7) Matsuo, S., K. Nishida and S. Yamashita; Engineering Properties of the Weathered Granitic Soils, Soil and Foundation, Vol. 109, No. 3, pp. 19-23 (1967) in Japanese