

Ion Current from Radio Frequency Ion Source

By

Haruyuki FUJITA*

(Received March 30, 1968)

The ion current from a Thonemann radio frequency type ion source for the Cockcroft-Walton accelerator was measured as a function of the probe voltage and the gas flow.

A maximum ion current of 4 mA was obtained at a probe voltage of 4 kV.

1. Introduction

Thonemann type ion source¹⁾ have been widely used with a low voltage accelerator for generation of high intensity neutron source because of the simplicity of construction and operation. The Cockcroft-Walton type accelerator of the Department of Nuclear Engineering is equipped with a Thonemann type ion source.

Ion sources of this type have two technical problems; the first is to maintain an intense ionization in the plasma chamber, and the second is to design the electrode system for extraction of ions and for focusing of the ion beam²⁻⁶⁾.

As a fundamental approach to these problems, its several characteristics have been studied.

2. Experimental Equipment

The Thonemann type ion source used for this purpose consists of a plasma chamber (ionization chamber) made of pyrex glass and a radio frequency coil as shown in Fig. 1. The chamber has a probe electrode to force ions out and an aluminum canal enveloped by a quartz sleeve. Hydrogen gas is supplied through a palladium leak by which the rate of gas flow into the chamber is controlled. The gas pressure becomes constant of itself because the rate of gas flow out through the canal balances automatically with the rate of gas flow into the chamber through the palladium leak.

The probe voltage E is supplied between the probe electrode (positive) and the canal (grounded). The radio frequency coil is a part of the tank circuit of the radio frequency oscillator as shown in Fig. 2. The frequency of the oscillator is 22.9 Mc/s.

* Department of Nuclear Engineering

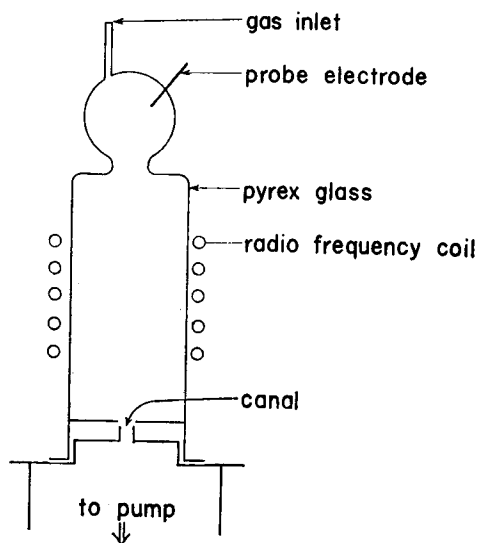

Fig. 1. Construction of the ion source

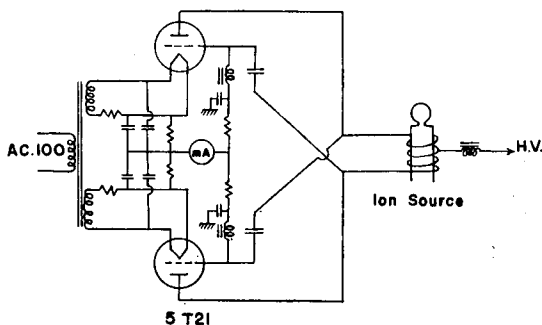

Fig. 2. Radio frequency oscillator circuit

Fig. 3 shows the lower part of the plasma chamber. The canal is an aluminum cylinder with a brim. The canal has an outer diameter 7 mm, an inner diameter 3 mm and a length 12 mm. The quartz sleeve is 12.5 mm long. A partition of pyrex glass is fixed near the bottom of the chamber. The ion current was measured for two different values, 2 mm and 3 mm, of the distance from the lower face of the partition down to the top of the canal. The ion beam extracted through the canal was collected by a flat copper plate at 50 mm down from the exit of the canal.

3. Results and Discussion

The ion current was measured as a function of the probe voltage, rate of gas flow, and the distance between the partition and the canal. The results are shown

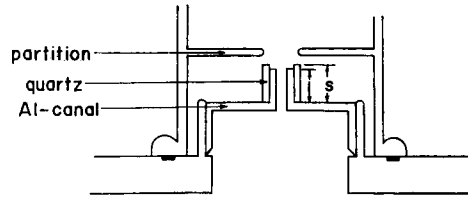

Fig. 3. Lower part of the chamber
 l: aluminum canal length is 12 mm.
 s: enveloped quartz length is 12.5 mm.

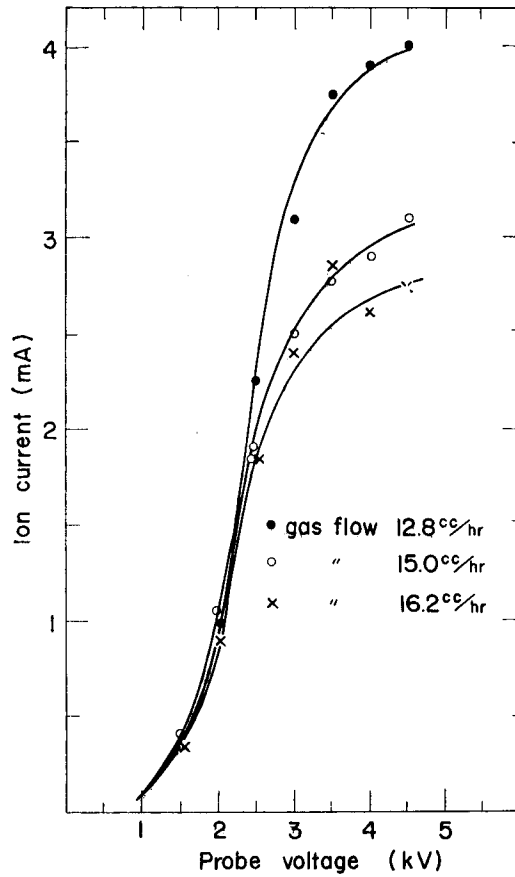

Fig. 4. In case of the distance from the lower face of the partition down to the top of the canal is 2 mm,

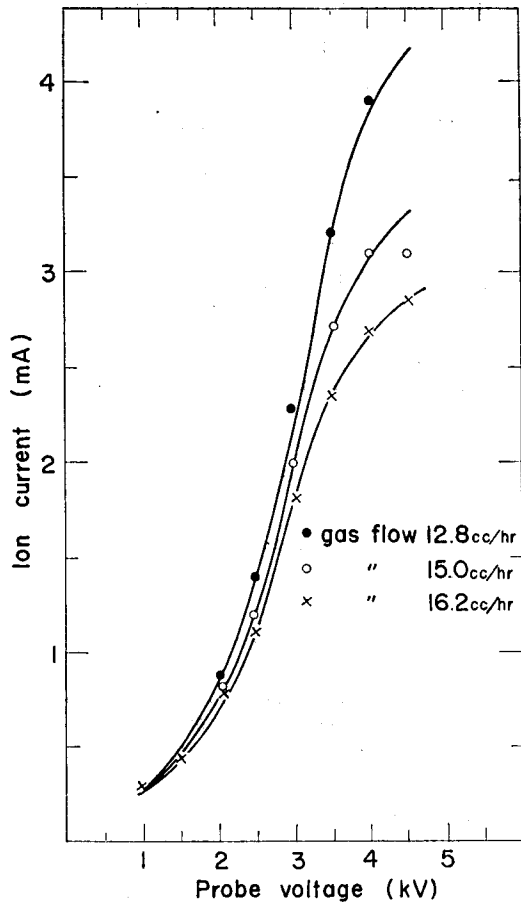

Fig. 5. In case of the distance from the lower face of the partition down to the top of the canal is 3 mm.

in Figs. 4 and 5.

In the case of the ion current extracted by a intense electric field from a plasma produced by a low voltage arc source, the current is limited by the space charge. The mechanism of ion extraction from a plasma is usually interpreted by the Langmuir theory⁷.

The beam current is increased approximately in proportion to $E^{3/2}$ up to 2 mA as an increasing function of the probe voltage E . In the range above 2 mA, the ion current shows deviation from the Langmuir theory, probably by the effect of gas flow. In this range a larger ion current was obtained with a lower rate of gas flow. In practical cases, the maximum value of the ion current should depend on the shape of the canal and is limited by initiation of arc discharge.

It was observed that the flow of ions outside the canal was in the form of a circular cone with a diameter of approximately 30 mm on the collector electrode. This information will be useful for design of the extracting electrodes.

The beam current measured with the collector electrode may contain a current due to secondary electrons emitted from the copper plate, and the current probably accounts for less than 15% of the total current.

Ganguly and Bakhru⁵⁾ obtained a maximum current of 1.5 mA at a probe voltage of 4 kV. In the present experiment, the maximum beam current observed is 4 mA for 4 kV probe potential.

Acknowledgments

The author wishes to express his thanks to Prof. T. Hyodo and Prof. H. Nishihara for the advices and encouragement on the experiment.

References

- 1) P.C. Thonemann, *Nature* **158** (1946) 61
- 2) C.D. Moak et al, *Nucleonics* **9** (3) (1951) 18
- 3) P.C. Tonemann and Harrison, Unclassified Report AERE GP/R 1190 (1955)
- 4) H.P. Eubank et al, *Rev. Sci. Instr.* **25** (1954) 989
- 5) A.K. Ganguly and H. Bakhru, *Nucl. Instr. and Methods* **21** (1963) 56
- 6) The CERN Proton Synchrotron Chapter V. CERN **60** 26
- 7) I. Langmuir and K.B. Blodgett, *Phys. Rev.* **24** (1924) 49