

Aperture-Coupled Beam-Scanning Patch Array with Parasitic Elements Using a Reconfigurable Series-Fed Phase-Shifting Structure

Wenyi Shao, Bo Yang, Hiroyuki Kamada, and Naoki Shinohara, Senior *Member, IEEE*

Abstract— In this letter, we propose a reconfigurable series-fed phase-shifting structure with movable metal plate for active millimeter wave beam-scanning application. The proposed phase-shifting structure can be equivalent to a certain number of phase shifters in the series-fed network. It can be easily controlled with only one metal plate, which further simplify the design of control system for phase shifters and reduce the cost. A prototype of 1-D aperture-coupled patch array with parasitic elements at 28GHz is designed, fabricated and measured for verifying the performance of the proposed phase-shifting structure. The measurement results at 28 GHz show 1-D beam-steering capability with maximum steering angle of ~ 22 deg at H-plane can be achieved, revealing great potentials for developing the simple control and cost-effective active phased array for millimeter wave wireless power transmission application.

Index Terms— Active antenna, Beam scanning, Reconfigurable phase shifter, Series-fed phase-shifting.

I. INTRODUCTION

Reconfigurable active beam-scanning antenna [1]-[2] has attracted great interest in the application of millimeter wave (mmWave) wireless power transmission (WPT) in recent years, due to the potential for enabling wireless powering of massive Internet of Everything (IoE) networks within a certain scanning range [3]. At mm Wave bands, it allows deploying large scale antenna arrays with high gain in small physical size, which provides higher end-to-end WPT efficiency compared with sub 6 GHz bands. Moreover, the wide radio spectrum of mmWave bands enables the co-existence of wireless power transfer (WPT) and information transfer in communication networks [4] by using the active beam-scanning antenna system.

Conventionally, active electronically scanned phased array

Manuscript received XXXX XX, XXXX; revised XXXX XX, XXXX; accepted XXXX XX, XXXX. Date of publication XXXX XX, XXXX; date of current version XXXX XX, XXXX. This work was supported by the Microwave Energy Transmission Laboratory (METLAB), Research Institute for Sustainable Humanosphere, Kyoto University and National Institute of Information and Communications Technology (NICT), JAPAN (Grant Number 02401). (Corresponding author: Bo Yang.)

The authors are with the with the Research Institute for Sustainable Humanosphere, Kyoto University, Uji 611-0011, Japan (e-mail: wenyi_shao@rish.kyoto-u.ac.jp, yang_bo@rish.kyoto-u.ac.jp, hiroyuki_kamada@rish.kyoto-u.ac.jp, shino@rish.kyoto-u.ac.jp).

Color versions of one or more of the figures in this communication are available online at <http://ieeexplore.ieee.org>.

Digital Object Identifier XXXXXXXXXXXXXXXXXXXX

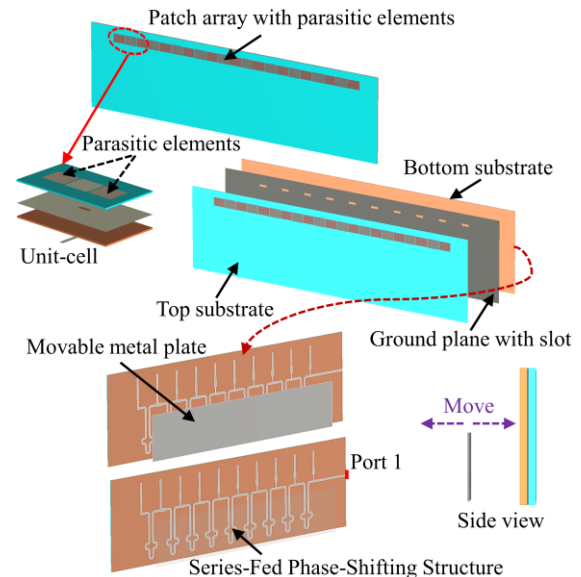

Fig. 1. Schematic of proposed aperture-coupled patch array with parasitic elements using a reconfigurable series-fed phase-shifting structure at 28GHz.

(AESPA) [5]-[6] and mechanically scanning antenna (MSA) are two common techniques to achieve flexible beam scanning. In MSA system, it requires a dedicated and extra tracking and pointing system for high-precision beam scanning, which limits its scanning speed. But for the large-scale AESPA, a very large number of active elements such as high-speed RF switch and phase shifter with higher bias voltage and power-handling capability are required to achieve the high-power beam scanning, which makes the whole system expensive and high power consuming, particularly at mmWave bands.

So far, many attempts such as design of new low-cost phase shifter [7]-[8] and improvement of antenna feeding structure [9] have been made to reduce the system complexity and cost. But the main challenge or issue of reducing the number of active elements and simplifying control system is not well addressed yet in these studies. A large number of phase shifters still need to be utilized and controlled independently. Besides, the design of phase shifter as a key component in active phased array often involves some special materials or elements such as non-linear PIN diode [8], ferroelectric material [10], and MEMS [11] which put forward higher requirements for multichannel bias voltage control system, manufacturing, and component packaging process. This further leads to high research and development costs in the early experimental stage.

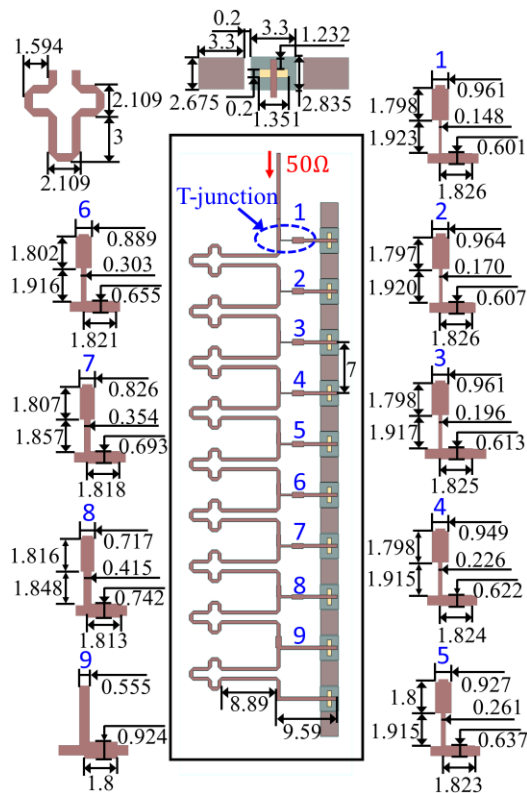

Fig. 2. Specific design dimensions of one-by-ten series-fed phase-shifting structure and unit-cell of aperture-coupled patch array (unit: mm). Noted that the yellow part represents the slot.

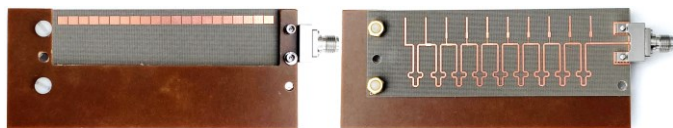

Fig. 3. Prototype of the proposed aperture-coupled patch array with parasitic elements using a reconfigurable series-fed phase-shifting structure at 28 GHz. Noted that the supporting structure around antenna is made of Teflon material.

In this letter, we introduce a reconfigurable series-fed phase-shifting structure with movable metal plate for active beam-scanning. The proposed phase-shifting structure can be equivalent as a certain number of phase shifters in the series-fed network, which can be easily controlled with only one metal plate. It can further simplify control system for phase shifters and reduce the cost. In order to verify the beam-steering capability of the proposed reconfigurable phase-shifting structure, a prototype of 1-D aperture-coupled patch array with parasitic elements at 28 GHz is fabricated and measured.

II. DESIGN OF APERTURE-COUPLED BEAM-SCANNING ARRAY

A. 1-D Patch Array with Parasitic Elements

The proposed aperture-coupled patch array with parasitic elements using a reconfigurable series-fed phase-shifting structure operating at 28 GHz is illustrated in Fig. 1, which has a size of 89 mm × 29 mm. It can be divided into six layers: 1-D microstrip patch array with parasitic elements, top substrate, ground plane with slot, bottom substrate, series-fed phase-shifting structure and movable metal plate. The top and bottom substrate are all the same, which has a thickness of 0.2 mm, a

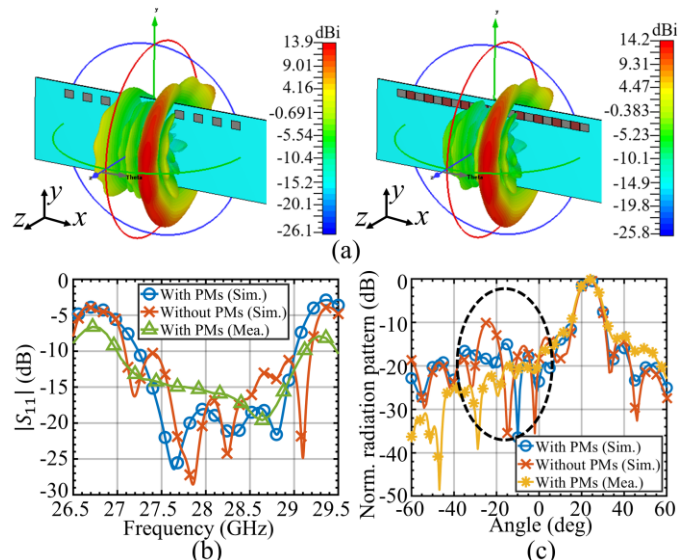

Fig. 4. (a) Simulated 3-D radiation patterns of proposed aperture-coupled patch array with PMs (right) and without PMs (left) at 28GHz. (b) $|S_{11}|$ response. (c) Comparison of normalized radiation patterns at xoz plane.

TABLE I
SPECIFIC RADIATION PATTERNS CHARACTERISTIC OF PROPOSED PATCH ARRAY WITH PMs AND WITHOUT PMs

	With PMs (Sim.)	Without PMs (Sim.)	With PMs (Mea.)
-3dB Beamwidth (°)	10	10	9.6
Realized gain (dBi)	14.2	13.9	13.2
Side lobe level (dB)	-13.6	-9.8	-12.3
Beam steering angle (°)	23	23	22

relative permittivity of 2.59 and loss tangent of 0.0017. The slot transition structure is utilized to indirectly connect patch array with parasitic elements and series-fed phase-shifting structure.

The specific design dimensions for proposed one-by-ten series-fed phase-shifting structure and the unit-cell of proposed patch array is shown in Fig.2. The phase-shifting structure has one input port with the impedance of 50Ω and line width of 0.555 mm and ten output ports. The T-junction structure with different branches [12] is utilized to achieve approximate equal power division at each port. The prototype of the fabricated 1-D aperture-coupled patch array is shown in Fig.3. Because the substrate is soft and thin, the fabricated antenna is fixed on a supporting plate. It should be noted that the supporting plate around antenna is made of low-loss Teflon material. Fig.4 (a) shows the 3-D radiation pattern of the proposed aperture-coupled patch array with parasitic elements (PMs) and without parasitic elements, respectively. It can be clearly seen from Fig. 4(b)-(c) that the radiation pattern can be further improved by using parasitic elements, while maintaining good performance of $|S_{11}|$ that is about -15 dB at 28 GHz. In constate to microstrip patch, the parasitic elements have different resonant lengths that introduce extra resonances [13]-[15]. This interlace of resonant frequencies further broadens impedance bandwidth of proposed patch array. Besides, the side lobe level can be effectively suppressed and reduced by more than 3 dB from -9.8 dB down to -13.6 dB. Table 1 shows the specific radiation patterns characteristic of proposed aperture-coupled patch array with and without parasitic elements.

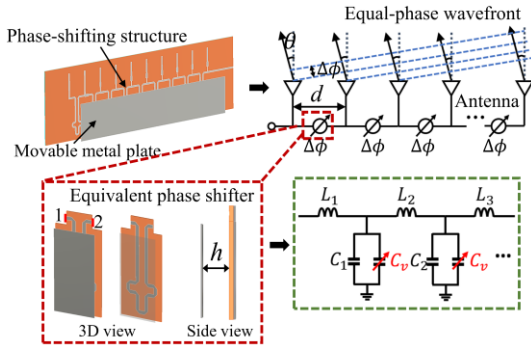

Fig. 5. Principle of proposed reconfigurable series-fed phase-shifting structure.

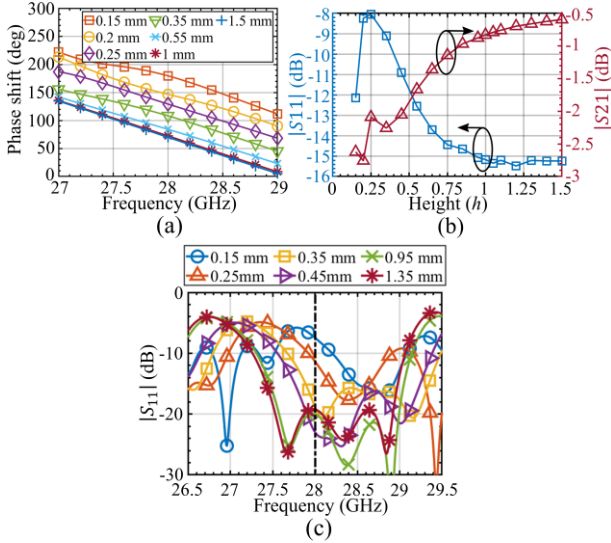

Fig. 6 (a) Performance of phase shift for single equivalent phase shifter with different h . (b) Simulated $|S_{11}|$ and $|S_{21}|$ response for single equivalent phase shifter with different h at 28GHz. (c) Simulated $|S_{11}|$ response for the proposed aperture-coupled patch array with different h .

B. Reconfigurable Series-fed Phase-shifting Structure

Besides, an ultrathin metal plate having size of 69 mm \times 14 mm is placed behind the series-fed phase-shifting structure, and can be moved back and forth like a piston to obtain the different phase responses at each unit of the patch array for achieving different beam-scanning angles, as shown in Fig.5(a). The equivalent phase shifters provide the same phase shift ($\Delta\phi$) between antenna elements in series-fed network, which further steer the beam towards a desired direction (θ). The relationship between phase shift and steering angle at designed wavelength (λ) and antenna spacing (d) is determined as

$$\Delta\phi = 2\pi d \sin \theta / \lambda \quad (1)$$

The proposed phase-shifting structure can be seen as a meander microstrip line with moveable metal plate. According to [16]-[17], the corresponding equivalent L - C is illustrated in Fig.5. The variable capacitance C_v can be continuously tuned by changing the distance (h) between metal plate and meander microstrip line based on high precision linear motor, which changes phase velocity of the meander microstrip line. Thus, different phase shifts could be produced with different h . Besides, all equivalent phase shifters can be controlled with only one metal plate, which further simplify the design of control system for phase shifters and reduce the cost. Based on full-wave simulation in CST Microwave Studio, the phase shift

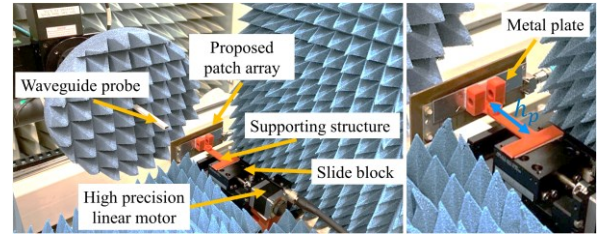

Fig. 7. Photograph of near-field measurement setup for proposed reconfigurable aperture-coupled patch array at 28GHz.

for single equivalent phase shifter with different h is calculated, and shown in Fig.6(a). When h changes from 0.15 to 1.5 mm, the phase shift correspondingly changes from 179.7 degrees to 69.9 degrees. The range of phase shift for single equivalent phase shifter can reach ~ 110 degrees, which provides a maximum theoretical beam scanning angle of ~ 25.8 degrees with antenna spacing of 0.7λ according to Eq. (1). Besides, Fig.6(b) shows the simulated $|S_{11}|$ and $|S_{21}|$ response of the equivalent phase shifter with different h at 28GHz. As the metal plate gradually approaches phase-shifting microstrip line structure, the $|S_{11}|$ and $|S_{21}|$ would deteriorate owing to the impedance mismatch caused by the metal plate. Nevertheless, the $|S_{11}|$ can be kept less than ~ 8 dB at $h = \sim 0.25$ mm, and eventually maintained at a low level of ~ -15 dB. The insertion loss within the height variation range from 0.15 to 1.5 mm can be also maintained at an acceptable level of $< \sim 2.5$ dB. Since the performance of phase shift for single equivalent phase shifter is particularly sensitive to h when h is small, it may introduce additional effects on impedance performance for the proposed patch array. Fig.6(c) shows the corresponding $|S_{11}|$ response with different h for the proposed patch array. Similarly, due to impedance mismatch caused by the metal plate, the $|S_{11}|$ would also deteriorate with the approaching of the metal plate to microstrip line structure. When $h < 0.25$ mm, the $|S_{11}|$ reaches a level of < -10 dB that is not acceptable. However, starting from 0.25 mm, the $|S_{11}|$ can be stably maintained below -10 dB.

III. EXPERIMENTAL MEASUREMENTS AND DISCUSSION

Fig.7 illustrates near-field measurement setup for proposed reconfigurable aperture-coupled patch array at 28GHz. It consists of six main parts: Ka-band waveguide probe, proposed patch array, a metal plate, 3-D printed supporting structure, slide block, high precision linear motor with the motion resolution of 0.001 mm (ALZ-4011-GOM, CHUO Precision Industrial). A metal plate is placed behind proposed patch array, and can be moved back and forth through slider block driven by linear motor. The motion direction of it is represented by the blue double arrow line. Due to the limitation of the ultra-thin substrate, it is very difficult to ensure the perfect flatness of fabricated patch array although the Teflon supporting plate is utilized. In other words, even if the metal plate and the phase-shifting structure are stuck together, there is still a gap between them. The initial distance between the metal plate and the phase-shifting structure is hardly measured. In our experiment, we tried to find the radiation beam with scanning angle of 0 degree, and defined the current position of the metal plate in this case as the initial position of measurement. Then, the metal plate is moved in increments of 0.1 mm with

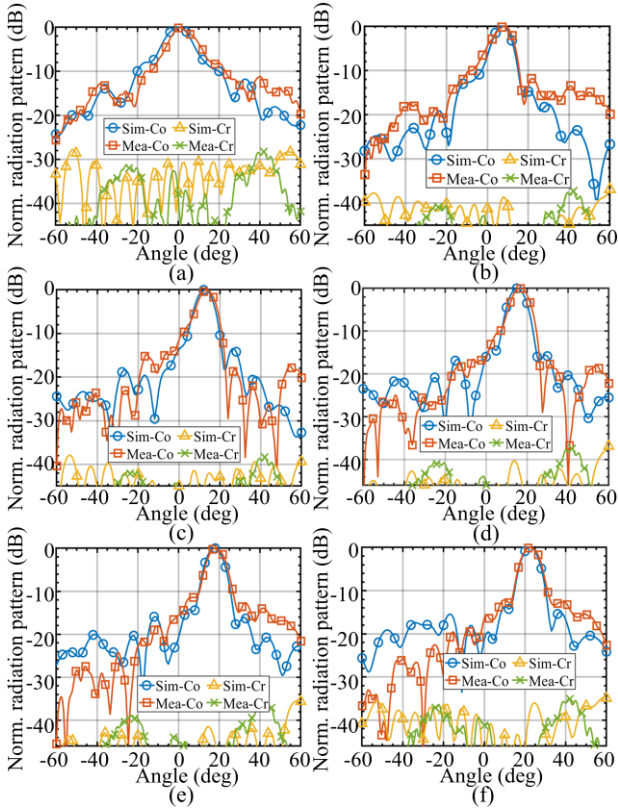

Fig. 8. Simulated and measured normalized H-plane radiation patterns of proposed reconfigurable patch array for six positions of metal plate at 28GHz. (a) $h_p = 0$ mm. (b) $h_p = 0.1$ mm. (c) $h_p = 0.2$ mm. (d) $h_p = 0.3$ mm. (e) $h_p = 0.4$ mm. (f) $h_p = 1.2$ mm.

reference to the defined initial position. h_p represents the distance from the initial defined position.

Due to page length limit, the simulated and measured normalized Co-/Cr-Pol radiation patterns of proposed reconfigurable patch array for six positions ($h_p = 0, 0.1, 0.2, 0.3, 0.4, 1.2$ mm) of metal plate at 28GHz are respectively illustrated in Fig. 8. As the metal plate is moved away from phase-shifting structure of proposed patch array, the radiation beam is steered accordingly. The side lobe levels can be maintained well as the steering angle increases, which is less than -10dB in all cases. Besides, there is a good consistency between the simulation and measurement results in terms of realized gain, steering angle and -3dB beamwidth as shown in Fig.9, which validates the performance of proposed reconfigurable patch. Fig. 9 (a) shows the simulated and measured peak gain with different h_p at 28GHz. The maximum measured peak realized gain is about 13.2 dBi with maximum steering angle of ~ 22 deg. When the metal plate is very close to the phase-shifting structure, the phenomenon of impedance mismatch occurs, which leads to reduce gain, and widen -3dB beamwidth of the radiation beam as shown in Fig.9(b). As mentioned earlier, the performance of phase shift for the equivalent phase shifter is particularly sensitive to the distance between metal plate and phase-shifting structure. The perfect flatness of fabricated patch array cannot be guaranteed, owing to the limitation of manufacturing techniques, which may introduce additional loss. Compared with the simulated results, the measured gain is lower, especially when h_p is small. Although the beam-steering capability of proposed reconfigurable phase-shifting structure

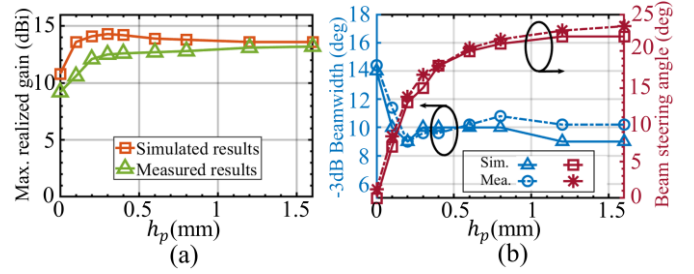

Fig. 9. (a) Simulated and measured peak realized gain with different h_p at 28GHz. (b) Simulated and measured -3 dB beamwidth and beam steering angle with different h_p at 28GHz.

TABLE II
PERFORMANCE COMPARISON BETWEEN THE PROPOSED DESIGN AND REPORTED WORKS

Ref.	Scanning technology	f (GHz)	Max. scan angle (Deg)	Bias voltage (V)	Fabrication	Independent control of phase shifter
[11]	MEMS	15	14	16	Complex	Yes
[7]	BST Film	12	25	180	Complex	Yes
[8]	PIN Diode	1.5	28	No report	Complex	Yes
[9]	Varactor	5.8	~ 21	100	Complex	Yes
[13]	Piezoelectric transducer	8~26.5	27	60	Simple	Yes
This work	metal plate	28	~ 22	\times	Simple	No

is verified, an obvious disadvantage in our case is that the whole system is not compact because of using a large size linear motor. In fact, the metal plate can be easily controlled by piezoelectric bending actuator or voice coil motor with smaller physical size at a very low cost. But this letter mainly focuses on the verification of reconfigurable mechanism of proposed series-fed phase-shifting structure. Besides, by using a thinner substrate, the proposed phase shift structure can be further optimized to keep good performance of return loss while maintaining low insertion loss and wide range of phase shift without increasing the size of it. Table II gives a brief comparison of the proposed patch array with other designs. Compared with other type of mmWave phase shifter based on varactor or PIN diode with low input power, the proposed reconfigurable phase-shifting structure only includes the copper layer and dielectric substrate, which could withstand higher input power. It reveals a great potential for high-power applications such as WPT at mmWave bands.

IV. CONCLUSION

A reconfigurable series-fed phase-shifting structure with movable metal plate for active beam-scanning at 28GHz is proposed in this letter. Only one metal plate is utilized, and moved back and forth like a piston to obtain the different phase shift, which steer the beam towards a desired direction. Besides, a prototype of 1-D aperture-coupled patch array with parasitic elements at 28 GHz is fabricated and measured. It has been demonstrated that we can achieve 1-D beam-steering capabilities with maximum steering angle of ~ 22 deg in H-plane with ~ 13.2 dBi of maximum realized gain and low side-lobe. This proposed phase-shifting structure could further simplify control system for phase shifters and reduce the cost.

REFERENCES

- [1] C. H. Wu and T. G. Ma, "Pattern-Reconfigurable Self-Oscillating Active Integrated Antenna with Frequency Agility," *IEEE Trans. Antennas Propag.*, vol. 62, no. 12, pp. 5992-5999, Dec. 2014.
- [2] H. Pablo Zapata Cano, Z. D. Zaharis, T. V. Yioultsis, N. V. Kantartzis and P. I. Lazaridis, "Pattern Reconfigurable Antennas at Millimeter-Wave Frequencies: A Comprehensive Survey," *IEEE Access*, vol. 10, pp. 83029-83042, Aug. 2022.
- [3] M. Wagih, G. S. Hilton, A. S. Weddell and S. Beeby, "Broadband Millimeter-Wave Textile Based Flexible Rectenna for Wearable Energy Harvesting," *IEEE Trans. Microw. Theory Techn.*, vol. 68, no. 11, pp. 4960-4972, Nov. 2020.
- [4] T. A. Khan and R. W. Heath, "Wireless Power Transfer in Millimeter Wave Tactical Networks," *IEEE Signal Process. Lett.*, vol. 24, no. 9, pp. 1284-1287, Sept. 2017.
- [5] R. J. Mailloux, *Phased Array Antenna Handbook*, 2nd ed. Norwood, MA: Artech House, 2005.
- [6] D. Parker and D. C. Zimmermann, "Phased arrays - part 1: theory and architectures," *IEEE Trans. Microw. Theory Techn.*, vol. 50, no. 3, pp. 678-687, Mar. 2002.
- [7] M. Nikfalazar et al., "Two-Dimensional Beam-Steering Phased-Array Antenna with Compact Tunable Phase Shifter Based on BST Thick Films," *IEEE Antennas Wireless Propag. Lett.*, vol. 16, pp. 585-588, July 2017.
- [8] J. Hu, Y. Li and Z. Zhang, "A Novel Reconfigurable Miniaturized Phase Shifter for 2-D Beam Steering 2-Bit Array Applications," *IEEE Microw. Wireless Compon. Lett.*, vol. 31, no. 4, pp. 381-384, Apr. 2021.
- [9] N. Hasegawa and Y. Ohta, "2-Dimensional Simple Beam Steering for Large-Scale Antenna on Microwave Power Transfer," *IEEE Trans. Microw. Theory Techn.*, vol. 70, no. 4, pp. 2432-2441, Apr. 2022.
- [10] S. I. M. Sheikh et al., "Analog/Digital Ferrite Phase Shifter for Phased Array Antennas," *IEEE Antennas Wireless Propag. Lett.*, vol. 9, pp. 319-321, Apr. 2010.
- [11] K. Topalli, Ö. A. Civi, S. Demir, S. Koc and T. Akin, "A Monolithic Phased Array Using 3-bit Distributed RF MEMS Phase Shifters," *IEEE Trans. Microw. Theory Techn.*, vol. 56, no. 2, pp. 270-277, Feb. 2008.
- [12] E. A. Soliman, A. Vasylychenko, V. Volski, W. D. Raedt and G. A. E. Vandenbosch, "Sixteen-by-sixteen array of series-fed aperture-coupled microstrip patch antenna array," *Microw. Opt. Technol. Lett.*, vol. 53, no. 11, pp. 2705-2711, Nov. 2011.
- [13] S. H. Wi, Y. S. Lee and J. G. Yook, "Wideband Microstrip Patch Antenna with U-Shaped Parasitic Elements," *IEEE Trans. Antennas Propag.*, vol. 55, no. 4, pp. 1196-1199, Apr. 2007.
- [14] G. Kumar and K. Gupta, "Broadband Microstrip Antennas Using Additional Resonators Gap-coupled to the Radiating Edges," *IEEE Trans. Antennas Propag.*, vol. 32, no. 12, pp. 1375-1379, Dec. 1984.
- [15] J. F. Lin and L. Zhu, "Bandwidth and Gain Enhancement of Patch Antenna Based on Coupling Analysis of Characteristic Modes," *IEEE Trans. Antennas Propag.*, vol. 68, no. 11, pp. 7275-7286, Nov. 2020.
- [16] T. Y. Yun and K. Chang, "A Low-cost 8 to 26.5 GHz Phased Array Antenna Using a Piezoelectric Transducer Controlled Phase Shifter," *IEEE Trans. Antennas Propag.*, vol. 49, no. 9, pp. 1290-1298, Sept. 2001.
- [17] J. Wu et al., "Compact, Low-Loss, Wideband, and High-Power Handling Phase Shifters with Piezoelectric Transducer-Controlled Metallic Perturber," *IEEE Trans. Microw. Theory Techn.*, vol. 60, no. 6, pp. 1587-1594, June 2012, doi: 10.1109/TMTT.2012.2189240.