

A NEW HIGH TEMPERATURE CALORIMETER OF GLASS.

By REICHI KONDO and EIJI SUITO.

Introduction.

The thermal analysis of reaction velocity which is a method of measuring reaction velocity from the temperature change of a reaction system caused by the reaction heat, has already been used in this laboratory as a new method of studying the kinetics of chemical reactions, both in the gaseous phase and in the liquid phase. In the latter case, a simple glass calorimeter reported by S. Horiba and K. Sato¹⁾ has hitherto been used in many experiments²⁾, but it is limited only to chemical reactions taking place at room temperature. If the reactions in the liquid phase at high temperatures (80°—150°C.), especially organic reactions, could be examined by the thermal analysis, very interesting results would be expected. For this purpose a high temperature calorimeter must be devised.

Recently, micro-calorimeters have been much improved for the purpose of measuring smaller changes at room temperature, and some high temperature calorimeters have already been made as well as the low temperature ones. Various micro-calorimeters have been constructed by F. A. Askew³⁾ (England), E. Lange and his co-workers⁴⁾ (Germany), and F. T. Gucker and his co-operators⁵⁾ (U. S. A.), etc. for extremely precise measurement of the heat of dissolution or dilution for the purpose of examining the theory of solution. The sensibility of these calorimeters achieves as much as 10^{-8} or 2×10^{-7} degree, but they are extremely complicated adiabatic or differential calorimeters, having 1000 or more thermojunctions. As to the high temperature calorimeters used for 80°—150°C., besides those for several hundred degrees used in the metallography, there are some for the measurement of the heat of dissolution of inorganic substances at high temperatures applied

-
- 1) S. Horiba and K. Sato, *This Journal*, **6**, 16 (1932).
 - 2) E. Suito, *ibid.*, **10**, 251 (1936), **13**, 74 (1939), **15**, 1 (1941).
T. Kosaki, *ibid.*, **12**, 21 (1938).
H. Matsuyama, *ibid.*, **12**, 168 (1938).
 - 3) F. S. Askew, N. S. Jackson, O. Gatty and J. H. Wolfenden, *J. Chem. Soc.*, 1362 (1934).
 - 4) E. Lange and E. O. Rounsefell, *Z. physik. Chem.*, **A 142**, 351 (1929).
E. Lange and K. P. Miscenko, *ibid.*, **A 148**, 161 (1930).
E. Lange and J. Monheim, *ibid.*, **A 149**, 51 (1930).
 - 5) F. T. Gucker, F. D. Ayres and T. R. Rubin, *J. Am. Chem. Soc.*, **58**, 2118 (1936).
F. T. Gucker, H. B. Pichard and R. W. Planck, *ibid.*, **61**, 459 (1939).

from the thermochemical stand-point by W. A. Roth⁶⁾, H. v. Wartenberg⁷⁾, W. Biltz⁸⁾, etc. and also those for the measurement of the heat of hydrogenation and halogenation of organic compounds used by G. B. Kistiakowsky and his co-workers⁹⁾. Each of them is an adiabatic metal calorimeter possessing a thermostat containing paraffin oil, or diethylene glycol, and fairly complicated.

The calorimeter used in this laboratory for the thermal analysis at room temperature is chiefly composed of a glass Dewar vessel and a Beckmann's thermometer and is characterized by simple construction and easy handling. As it is an isotherm calorimeter, cooling is exceptionally important. It is, therefore, important that cooling is easily carried out at high temperatures as at room temperature. Although, as mentioned above, a liquid having a high boiling point can be used as thermostat liquid, another new method was adopted in the present study. It is well known that any pure liquid has a definite boiling point under a given pressure. When this nature is applied to the thermostat, it is expected that the thermostat can be comparatively easily kept at a desired temperature by selecting the liquid or by regulating the pressure.

Using such a high temperature thermostat, a new high temperature calorimeter was constructed with a Dewar vessel as its component. Its efficiency was examined by a simple measurement of the heat of reaction.

Construction of the High Temperature Calorimeter.

(1) The Thermostat.

The thermostat used is a *vapour bath thermostat*, the vapour being obtained by boiling any liquid under a given pressure. As shown in Fig. 1, it consists of thermostat vessel, TV, and an air bath surrounding it. The air bath is enclosed by isolite brick and asbestos plates, and the suitable temperature is kept by means of the sand bath, SB, and the electric heaters, H_0 and H_0' , made of nichrome wire, 0.5 mm diameter and about 120 cm length. The thermostat vessel, TV, 9 cm inner diameter and 38 cm inner depth, is made of glass and coated about 3 mm thick with asbestos. The mouth is closed tightly by the rubber stopper, G_1 , and sealed with Piccin.

6) W. A. Roth and P. Chall, *Z. Electrochem.*, **34**, 185 (1928).

7) H. v. Wartenberg and H. Schütza, *Z. anorg. u. allg. Chem.*, **206**, 65 (1932).

8) W. Biltz, G. Rohlfis and H. V. v. Vogel, *ibid.*, **220**, 113 (1934).

9) G. B. Kistiakowsky, H. Romeyn, J. R. Ruhoff, H. A. Smith and W. E. Vaughan, *J. Am. Chem. Soc.*, **57**, 65 (1935); and *ibid.*, **57**, 876 (1935), **58**, 137, 145 (1936), **59**, 831 (1937), **60**, 440, 2764 (1938), **61**, 1868 (1939).

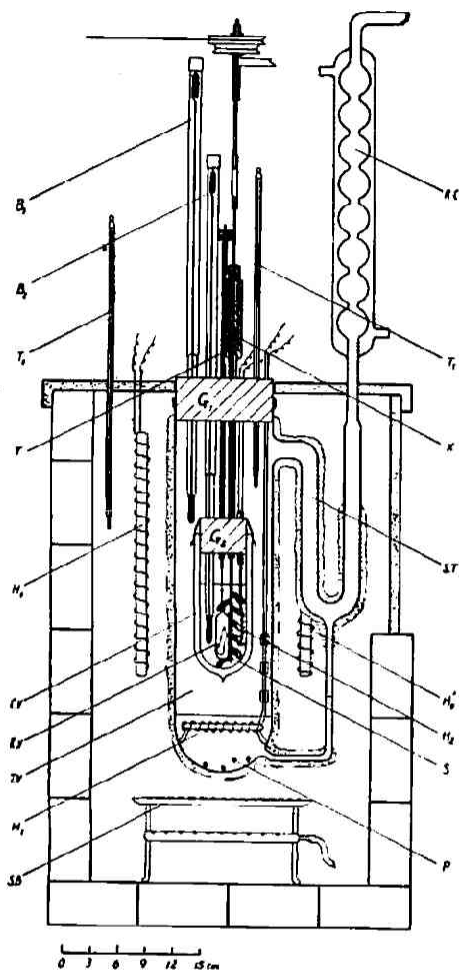

Fig. 1. Apparatus.

The thermostat liquid, 200 ml of water, is boiled by the electric heater, H_1 , made of nichrome wire of 0.5 mm diameter and about 100 cm length, and P is a tetrahedral platinum block used as 'Siedestein'. The thermostat vessel is connected with a pressure reservoir (shown in Fig. 2) through the side tube, ST , 1.5 cm diameter, and the reflux condenser, RC , in order that the pressure may be kept constant. The pressure reservoir, A , is of 5 litre capacity and its temperature is kept at $20 \pm 0.005^\circ\text{C}$. by the thermostat, W . M_1 and M_2 are manometers, and A'

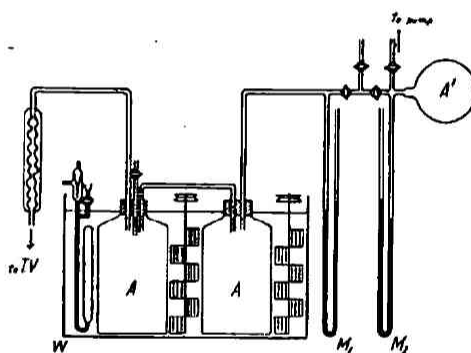

Fig. 2.

is an auxiliary air reservoir to regulate the pressure in A and is of 4 litre capacity.

(2) The Calorimeter Vessel.

In the middle of the thermostat vessel is hung the calorimeter vessel, CV , consisting of a glass Dewar vessel, silvered or unsilvered, of 60—150 ml capacity. Liquid paraffin, nitrobenzene, or glycerine is used as the calorimeter liquid, in which the Beckmann's thermometer, B_2 , the stirrer, S , the electric heater, H_2 , and the reaction vessel, RV , are submerged. The rubber stopper, G_2 , is completely covered with sealing wax. The stirrer has the insulating branch, X , containing liquid paraffin and is driven at about 200 r. p. m. by a motor. The electric heater, H_2 , is of constantan wire and its resistance is 1.095 ohm according to the

accurate measurements made by means of a Wheatstone bridge at the experimental temperature (100.6°C.).

(3) The Reaction Vessel.

If the reaction takes place directly in the calorimeter vessel at a high temperature, the measurement becomes not only difficult but also inaccurate. In the present experiment, therefore, the reaction is allowed to take place in the reaction vessel, and the heat radiated or absorbed is transferred to the calorimeter liquid and its temperature change was measured.

The reaction vessel, RV, is a thin-walled glass bottle, 0.1 mm thick and of 10 ml capacity, sustained with a glass rod, Y, in the calorimeter liquid. Reacting substances, one of which is contained in an ampulla, are sealed in the reaction vessel.

Nature of the High Temperature Calorimeter.

(1) Sensibility of the vapour bath thermostat.

The sensibility of this thermostat was examined at about 100°C. using water as the thermostat liquid.

After ensuring the thermostat vessel for absence of any leakage of pressure at room temperature, the temperature was raised to about a desired degree by means of the sand bath and the electric heater H_0 . As the relation between the boiling point of water and its vapour pressure is known, the thermostat vessel could be kept at a given temperature, boiling constantly the thermostat liquid by regulating the pressure of the gas reservoir A and the electric current to the heater H_1 .

The temperature gradient in the thermostat vessel was examined by placing the two contacts of a copper-constantan thermojunction at the top and the bottom of the thermostat. In that case the burner of the sand bath and the electric current through H_0 and H_1 were regulated so that the temperature difference might be kept at a minimum. The value obtained was less than 0.01°C. under the experimental conditions. The optimum temperature of the air bath was $85 \pm 2^\circ\text{C}$.

The electric heater H_1 was placed as near the water surface as possible to decrease the error of the boiling point caused by hydraulic-pressure.¹⁰⁾ The influence of room temperature was hardly recognized, as the gas reservoir was dipped

10) The pressure increase of 5 cm of water corresponds to that of about 3.8 mm.Hg, and the boiling point varies by 0.19°C. near 100°C.

in the thermostat.¹¹⁾ With such cares, the temperature of the calorimeter was kept constant for many hours with the accuracy of $\pm 0.005^\circ\text{C}$. at any degree between 96°C . (657 mm Hg) and 101°C . (788 mm Hg). One of the instances is shown in Fig. 3. This order of constancy is quite sufficient for the thermal analysis. If

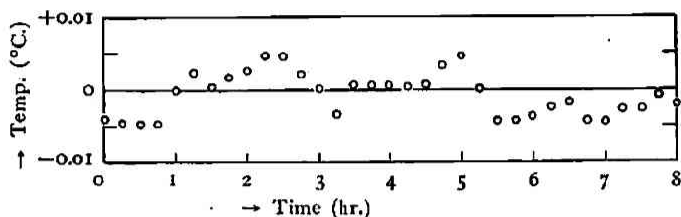

Fig. 3. Constancy of temperature of vapour bath thermostat.

some device is adopted to prevent the pressure leakage from the rubber stoppers G_1 and G_2 , it will be possible to cover a much wider range of temperatures and, besides, if a suitable thermostat liquid is used, the thermostat of any desired temperature will be obtainable.

(2) Cooling constant and water equivalent of the calorimeter vessel at high temperatures.

The method of measuring the cooling constant, K , and water equivalent, W , of the calorimeter vessel is the same as in the case of the calorimeter used for the thermal analysis at room temperature. Namely, it is to measure how the temperature rises when a given electric current flows through the heater H_2 and how it naturally falls down after the switch-off. The result of an instance, in which 80 ml of liquid paraffin was used as the calorimeter liquid, is tabulated in Table I. Similar to the case of room temperature, the Newton cooling constant showed a good constant value, its mean value $K_m = 0.0353$, which is almost twice as large as that in the case of room temperature. The water equivalent was found to be 53.0 cal.

In order to increase the water equivalent and make the cooling constant smaller, a silvered Dewar vessel of large capacity (140 ml) was used, and the result is shown in Table II. From the table it is found that K is very small (about 1/6 of the unsilvered), but that it becomes smaller in lapse of time, and this is always perceived in the case of the silvered vessel. The value of the cooling constant obtained by extrapolation when $t=0$, was $K_0 = 0.0056$. The water equivalent was 81.7 cal.

11) If the temperature of the gas reservoir varies by 1°C ., the variation in the pressure becomes as large as 2.8 mm.Hg in the present apparatus and that of the boiling point becomes 0.14°C .

Table I.

Dewar vessel No. 1. (unsilvered)
liquid paraffin 80 ml., 100.6°C.

<i>t</i> (min.)	ΔT (°C.)	<i>K</i> (min. ⁻¹)
0	0.932	
5	0.781	0.0354
10	0.659	0.0346
15	0.550	0.0346
20	0.457	0.0356
25	0.382	0.0356
30	0.320	0.0356
35	0.268	0.0356
40	0.227	0.0355
45	0.191	0.0352

$$K_m = 0.0353$$

$$W = 53.0 \text{ cal.}$$

$$K = \frac{\log (\Delta T)_{t=0} - \log \Delta T}{0.4343 t}$$

Table II.

Dewar vessel No. 2. (silvered)
liquid paraffin 140 ml., 100.6°C.

<i>t</i> (min.)	ΔT (°C.)	<i>K</i> (min. ⁻¹)
0	0.870	
5	0.846	0.0053
10	0.826	0.0052
15	0.804	0.0052
20	0.785	0.0051
25	0.767	0.0050
30	0.751	0.0049
35	0.735	0.0048

$$K_0 = 0.0056$$

$$W = 81.7 \text{ cal.}$$

The facts that *K* at 100°C. is about a half of that at room temperature and that it is reduced to 1/6 when a silvered vessel is used, support the theoretical view that the cooling of the calorimeter is due mainly to radiation. The change of *K* with time in the case of the silvered vessel may be attributed to the fact that the conduction of heat along the glass wall (not according to Newton's law) is the predominant factor in the cooling in consequence of slightness of cooling by radiation.

The cooling constant was also measured by using nitrobenzene or glycerine as calorimeter liquid, and the results are tabulated in Table III. In this case the copper-constantan junction was used in place of a Beckmann's thermometer as the thermometer.¹²⁾

It has been found that, when a liquid of high viscosity such as liquid paraffin or glycerine is used as calorimeter liquid at room temperature, the equilibrium temperature *T*_e becomes a little higher than the temperature of the

Table III.

Dewar vessel No. 3. (unsilvered)
nitrobenzene 75 ml., 97.6°C.

<i>t</i> (min.)	$\Delta \theta$ (cm.)	<i>K</i> (min. ⁻¹)
0	12.06	
5	8.58	0.068
10	6.56	0.061
15	4.60	0.064
20	3.50	0.061
25	2.67	0.060
30	1.99	0.060
35	1.52	0.059

$$K_m = 0.062$$

glycerine 50 ml.

$$K_m = 0.060$$

12) θ is the deflection of the galvanometer-mirror (3.17×10^{-7} V, 1.51×10^{-8} A in sensibility) on the scale situated 1 m apart. $\Delta \theta$ is also considered to be proportional to ΔT ; $\Delta \theta = a \cdot \Delta T$. In the present experiment $a = 9.44$ cm/degree, and so with only one junction it is not so sensitive as a Beckmann's thermometer and more junctions will be needed.

thermostat T_0 , on account of the frictional heat due to stirring.¹¹ But it must be noted that, as the viscosity of the liquid is rapidly reduced with rising temperature, such an influence is scarcely perceived actually at 100°C. On the contrary, when any volatile liquid is used, T_c becomes lower than T_0 on account of the heat of evaporation even at room temperature, and at high temperatures the disparity is larger. Therefore, the liquid to be used for the high temperature calorimeter must be the one with a high boiling point or low vapour pressure, though of high viscosity at room temperature, and it must be stable at high temperatures.

Application of the High Temperature Calorimeter.

The Heat of Formation of Zinc Oxide.

As an application of the high temperature calorimeter, the heat of dissolution of metallic zinc and zinc oxide in 30% hydrochloric acid was measured and then the heat of formation of zinc oxide at 100°C. calculated.

Experimental Method and Results.

Zinc used was Merk's chemically pure sample, which was cleaned and broken into pieces. Zinc oxide was heated to redness in a crucible for 6 hours and made to tablets.

A weighed quantity of zinc or zinc oxide and an ampulla containing 30% hydrochloric acid (2.5 times as much as the equivalent quantity) were put in the reaction vessel. The thermostat was kept at 100.6°C, and the calorimeter liquid was heated by the heater H_2 to much the same degree as the thermostat and allowed to stand for about one hour. After the temperature of the calorimeter reached an equilibrium state, the reaction was started by breaking the ampulla by moving violently the glass rod Y up and down. At the same time the temperature rise was measured in the lapse of time with the Beckmann's thermometer B_2 . One of the results is shown in Fig. 4.

From the $\Delta T-t$ curve obtained and the following equa-

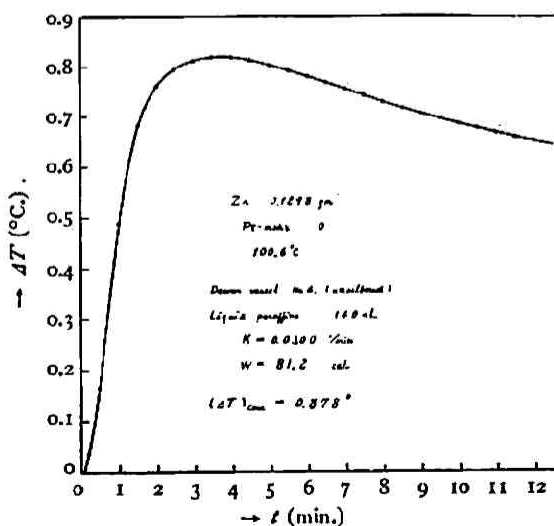

Fig. 4. An example of reaction.

tion¹³⁾ for correction of cooling, the temperature rise of the reaction system $(\Delta T)_{corr.}$ in the case of no cooling was calculated.

$$(\Delta T)_{corr.} = (\Delta T)_{t=t_1} + K \int_0^{t_1} \Delta T \cdot dt$$

(t_1 is a desired time after the end of the reaction.)

The cooling constant, K , and the water equivalent, W , were measured after each reaction by the method above mentioned.

It is reported that the reaction between metallic zinc and an acid is suddenly repressed to proceed smoothly under an extremely high pressure (300 kg/cm²).¹⁴⁾ In the present experiment, however, the reaction was completed in about 8 minutes, for the pressure generated was only 5 atmospheres. To get assured of this, another experiment was carried out using Pt-black¹⁵⁾ as catalyst, but the reaction proceeded almost at the same velocity. The reaction with zinc oxide was completed in about 12 minutes.

All the results obtained are tabulated in Table IV.

Table IV.

Heat of dissolution of Zn and ZnO in 30% HCl (2½ theoretical weight) at 100.6°C.

A. Zinc

No. of Dewar vessel	Wt. of sample (gm.)	$(\Delta T)_{corr.}$ (°C.)	Water equivalent, W (cal.)	Wt. of Pt-catalyst (mg.)	Heat of dissolution (Kcal/mol)
1	0.1077	1.077	51.7	8	33.80
2	0.1264	0.829	81.7	1.4	35.03
4	0.1298	0.878	81.2	0	35.91
mean					34.91

B. Zinc oxide

2	0.2288	0.635	82.4		18.61
2	0.1930	0.584	82.2		20.20
mean					19.40

13) The fundamental formula of the thermal analysis is as follows: $\frac{dT}{dt} + K \cdot \Delta T = \frac{Q}{W} \cdot \frac{dx}{dt}$, where Q is the heat of reaction.

Integrating from $t=0$ to t_1 (a time after the reaction), we get

$$\int_0^{t_1} dT + K \cdot \int_0^{t_1} \Delta T \cdot dt = \frac{Q}{W} \int_0^{t_1} dx$$

As $\int_0^{t_1} dx = a$ is the mol number of the reacting substance, $Q \times a$ becomes the whole quantity of the heat produced. Accordingly,

$$(\Delta T)_{t=t_1} + K \int_0^{t_1} \Delta T \cdot dt = \frac{Q}{W} \cdot a = (\Delta T)_{corr.}$$

14) G. Tamman and K. Bochow, *Z. anorg. u. alleg. Chem.*, 169, 33 (1938).

15) Pt-black was prepared in the following way: platinum colloid made by the Bredig method was precipitated, filtered, and dried. When it was dipped in hydrochloric acid, a part of it was dissolved and the solution turned yellow.

The Heat of Formation of ZnO.

As the present experiment is performed in a constant volume, 0.75 Kcal ($T = 373^\circ\text{K.}$) per mol must be subtracted for the reaction generating a gas. Therefore, the isobar heat of dissolution of Zn is 34.16 Kcal/mol. The heat of formation of ZnO at 100.6°C. can be calculated from the following equations.

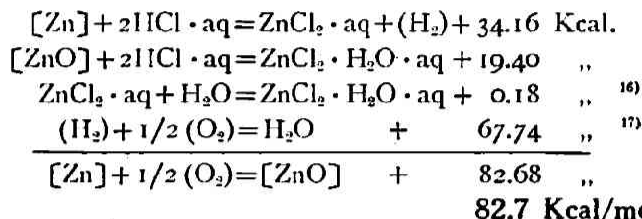

[] denote the solid phase and () the gaseous phase.

The result obtained may not be very accurate, but it agrees fairly well with the results obtained before, as shown in Table V.

Table V.
The heat of formation of ZnO.

Heat of formation obtained (Kcal/mol)	Temperature ($^\circ\text{C}$)	Heat of formation at 100°C (Kcal/mol)	Method*	Observer
84.82	—	—	direct	J. E. Moose ¹⁾ S. W. Parr
82.82	18	82.74	indirect	C. G. Maier ²⁾ O. C. Ralston
83.07 \pm 0.21	20	82.99	direct	G. Becker ³⁾ W. A. Roth
83.54	20	83.46	indirect	"
83.00 \pm 0.35	25	82.93	direct	C. G. Maier ⁴⁾ G. S. Parks C. T. Anderson
83.27 \pm 0.05	25	83.20	indirect	C. G. Maier ⁵⁾
82.91	50	82.86	indirect	W. A. Roth ⁶⁾ P. Chall
83.0	90	82.99	indirect	W. Biltz ⁷⁾ G. Rohlffs H. V. v. Vogel
82.7	100	82.7	indirect	Author.

(N. B.) * direct: direct measurement of the heat of combustion of Zn; indirect: indirect measurement calculated from the heat of dissolution of Zn and ZnO in an acid.

1) *J. Am. Chem. Soc.*, **46**, 2656 (1924). 2) *ibid.*, **48**, 372 (1926). 3) *Z. physik. Chem. A* **167**, 1 (1933). 4) *J. Am. Chem. Soc.* **49**, 2570 (1927). 5) *ibid.*, **52**, 2159 (1930). 6) *Z. Electrochem.* **34**, 185 (1928). 7) *Z. anorg. chem.* **220**, 113 (1934).

16) As the concentration of HCl was 30%, the heat of dilution of ZnCl_2 in this experiment was obtained from the following equation:

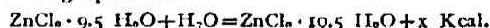

Calculating from the data of R. Fricke and J. Lücke (*Z. Electrochem.*, **35**, 637 (1929)), $x=0.15$ at 20°C. , and using its temp. coeff. in the case of common salt, the value (0.18 Kcal) at 100°C. is obtained.

17) From $68.31_3 \pm 0.010$ (temp. coeff. -0.00765) at 25°C. obtained by F. D. Rossini (*Bur. Stand. J. Res.*, **7**, 239 (1931)), the value at 100°C is sought.

In short, the present high temperature calorimeter is to be considered practically applicable for a chemical reaction. It is, moreover, inferred that, as the temperature of such a vapour bath thermostat is readily adjustable by regulating the pressure, any adiabatic high temperature calorimeter can be devised by utilizing such a procedure.

Summary.

(1) A high temperature glass calorimeter suitable for the thermal analysis of the reaction velocity at high temperatures has been made, and its construction mentioned.

(2) With a new idea regarding the high temperature thermostat, a vapour bath thermostat utilizing the vapour generated by boiling a liquid (water) at constant pressure, has been devised. A desired temperature is capable of being kept within the limit of 0.005°C . for many hours.

(3) The cooling constant and the water equivalent of the isothermal calorimeter (Dewar vessel) placed in such a thermostat has been examined.

(4) As an application of this calorimeter, the heats of dissolution of metallic zinc and zinc oxide in 30% hydrochloric acid have been measured, and from the values obtained the heat of formation of zinc oxide at 100°C . was calculated.

In conclusion, the authors have great pleasure in expressing their sincere thanks to Professor S. Horiba for his valuable guidance during the course of this research and to Mr. Hagihara for his kind suggestions.

*The Laboratory of Physical Chemistry,
Kyoto Imperial University.*

(Received August 5, 1941)