

Title	Ultra pressure : VIII. Material flow of attachments of high pressure apparatus (Commemoration volume dedicated to Prof. Shinkichi Horiba in celebration of his sixtieth birthday)
Author(s)	Kiyama, Ryo
Citation	The Review of Physical Chemistry of Japan (1947), 20: 73-75
Issue Date	1947-09-15
URL	http://hdl.handle.net/2433/46629
Right	
Type	Departmental Bulletin Paper
Textversion	publisher

ULTRA PRESSURE.

VIII. Material Flow of Attachments of High Pressure Apparatus.

By RYO KIYAMA.

In the report¹⁾ on packing for the closing of a hole or a piston according to the so-called Bridgman's type for the packing materials rubber, lead, copper, aluminium and its alloys are examined, and satisfactory results obtained by merely changing the dimensions of those materials. In the case of higher pressures than 2,000 kg/cm², an intensifier is used²⁾. In this case the resistance of the piston of the intensifier must be evaluated experimentally. In measurement of the resistance of the piston an unreliable part is the packing of the piston plug with rubber according to Bridgman's type (shown in Fig. 1) for long run. From the above mentioned reason author used steel instead of rubber or soft metals.

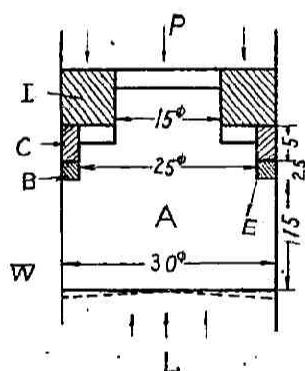

Fig. 1.

The structure of the piston plug is shown in Fig. 1. *A* is the plug body of the piston made of steel, *C* and *D* are steel rings; *B* is the packing ring made of the above cited materials *B* is fitted its space with pressures from two sides, the piston pressure *P* and the chamber pressure *L*; and the plug is free from leakage on the automatic compression principle.

When the materials of *B* are in the limits of their elasticity, the original dimension of *B* is restored after the release of pressure, but long duration of pressures or extra high pressure caused packing *B* to flow. Rubber (30m/m external, 15m/m internal diameter, 4~6m/m thickness) and such metals as lead, tin, copper, aluminium and its alloys (same external diameters, 25m/m internal diameters, thickness 1-2m/m) are used for *B*.

The results are satisfactory for metal packings, but the initial leakage of setting is dependent upon the kinds of the metal used and the order of completeness of turning. In the author's experiments under 5-6,000kg/cm² of gas pressure (*L*), the metal ring of *B* is slightly deformed and leakage is resisted by the attachment of *B* to the cylinder wall *W*. As the result of the flow of packing materials, *E*, the back of the plug is deformed by severe stresses. Fig. 2 is a

1) *This journal*, 19, 21 (1945).2) *This journal*, 19, 33 (1945).



Fig. 2.

microscopical photograph of the vertical section of A showing plastic flow of δ -part at the surface E which is of a different structure from the body of A . The sheet of plastic layer acts as a steel packing as B materials. Accordingly the author uses steel or special steel as hard as the cylinder wall, if it is desired.

For the pressure proof optical window¹⁾, polished surfaces of glass or quartz and steel were set without any cementing or packing materials, the author succeeded in setting two pieces only by pressing them hard. If there are any adhesive materials, it will be a cause of leakage, because polished surfaces will be destroyed in consequence of the flow of intermitted materials. As the same reason, the polished surface of steel is necessarily as hard as optical transparent materials.

Higher pressure or duration of pressing will cause the deformation of surface A facing L as is shown by dotted lines in Fig. 1, and the materials of A and its dimension must be carefully decided, though any protecting construction may be adopted.

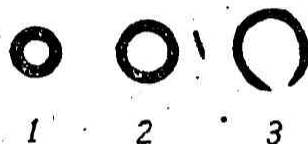

Fig. 3. The course of rupture by internal pressure.

It is different condition between flow of E and plastic rupture of steel pipe by the internal pressure without protection shown in Fig. 3. The former is sealed by protecting all sides, but the latter is a case of resistance of thickness of pipe for rupture without any protection. For the latter case the flow of material caused the internal pressure as is shown in Fig. 4 (b) and (c), which are microscopic photographs of sections of Fig. 3 (2) and (3). Fig. 4 (a) corresponds to Fig. 3 (1), not ruptured, where white portion is ferrite, black ground is pearlite, and the

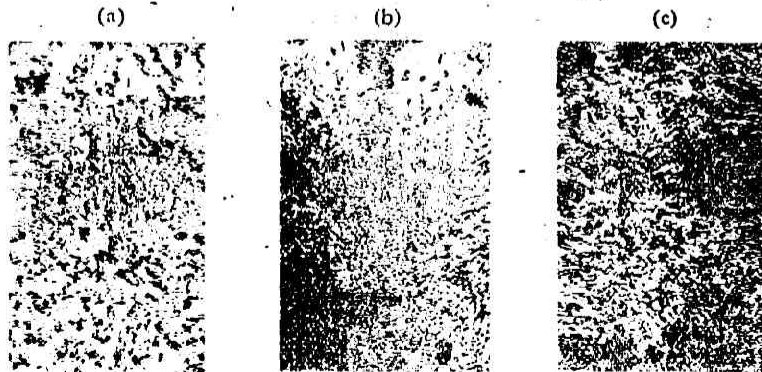

Fig. 4.

1) *This journal*, 19, 17 (1945).

structure of whole section is sound, contrary to (b) and (c) showing turbulent flow of structure.

Several theories have been proposed concerning the rupture criteria of a thick wall cylinder. These theories are used rather deciding cylindrical dimensions for engineering character than knowledge of rupture. There are not shown any traces of directions of stresses from ruptured sample in Fig. 4. If rupture comes after material flow, the same rule must hold good for glass hard steel as well as carbon steel. Glass hard steel cylinders are ruptured by internal pressure violently into pieces as a glass tube does, and material flow is not observed microscopically.

For brittle material, there is not seen any flow or plasticity practically, even in the case of all sides of forces, namely under hydrostatic pressure.

Two cases of solid states of amorphous and crystalline are classified from the point of molecular or atomic arrangement. It is enough entirely different for amorphous and crystalline substances in any cases of rupture. But the author considers that this opinion is not quite the genuine criterion of rupture. It will be more appropriate to consider that, even from the engineering stand point, at the time of rupture solid material go through the amorphous state or the crystalline state.

*The Laboratory of Physical Chemistry, College of Science,
Kyoto Imperial University.*