

An Econometric Analysis of the Philippine Economy

—An Attempt at Policy Simulation—

Edgardo P. ZIALCITA,* Pedro B. LUCAS,* Felix R. ALFILER,*
Wilhelmina C. MAÑALAC* and Shinichi ICHIMURA**

I Introduction

This study adopts fundamentally the same framework as the one for several econometric models built by the Department of Economic Research, Central Bank of the Philippines (CBP).¹⁾ Thus, it presents a small scale

model which attempts to reflect the main characteristics of the Philippine economy and permits also its policy analysis. A number of modifications have been made to improve the previously obtained results and to come up with more extensive analyses of the model and its implications.²⁾ The model focuses its attention on: 1. the channels of transmis-

* The Department of Economic Research, Central Bank of the Philippines, Manila, the Philippines

** 市村真一, The Center for Southeast Asian Studies, Kyoto University

1) More specifically, the present study benefits a great deal from the research work entitled "An Experiment with a Simple Model of the Philippine Economy" presented at the Third Central Banks Workshop on Econometric Modelling held in Manila on November 2-3, 1979. A good survey of other Philippine econometric models is made by Virgilio T. Velasco and presented at the International Conference held at the Center for Southeast Asian Studies, Kyoto University in 1979. It is available as V. T. Velasco, "A Review and Synthesis of Macro-Econometric Models of the Philippines," Philippine Development Studies Working Paper — 7902, Philippine Institute for Development Studies, July, 1979.

Prior to Central Bank's model, the best pioneering work of econometric models of the financial sector is: Jose Encarnacion, "A Monetary Submodel of the Philippine Economy, 1950-1969." This was constructed as a part of large models of the Philippine Economy reported in: Jose Encarnacion, Jr. *et al.*, *Econ-*

ometric Models of the Philippines, National Economic Council, the Republic of the Philippines, March, 1972. This model is simpler than the present model in concentrating the analysis on the behavior of Central Bank and its impact on the supply of money. The Philippine financial statistics are significantly modified in its classifications early 60's, so that the present model starts only after the period which this earlier work covered.

The present study was partly undertaken during W. C. Mañalac's stay at the Center for Southeast Asian Studies, Kyoto University in 1981-82. Hearty gratitude is expressed to Professor Mitsuo Ezaki for his valuable instructions and Mr. Satoshi Yasuda for his help in programming and use of computer facilities at Kyoto University.

2) Some important changes may be listed: 1. respecifications of the equations for taxes, real private fixed investments, changes in real stocks, the demand for total liquidity and Monetary Authority's claims on deposit money banks; 2. use of deposit money banks' domestic credits as the variable for credit availability in the private sector; and 3. specification of an equation for deposit money banks' net foreign assets.

sion of the effects of monetary policies to target variables like prices, real income and the balance of payments; and 2. the feedback process from non-monetary to domestic monetary variables.

In this model, the volume of credits and the interest rate interact with real variables in the determination of real fixed private investments, increase in stocks, and subsequently, real income. In addition, the level of domestic prices is determined by the ratio of the demand for and supply of total liquidity. Meanwhile, the public is allowed to adjust its actual to desired money holdings through the exchange of local currency for foreign goods and securities. This implies that the external sector affects the monetary base; i. e., reserve money has an endogenous component, the net foreign asset position of Central Bank.

The model consists of twenty (20) equations, of which thirteen are behavioral and seven are identities. Table 1 lists the model's endogenous and exogenous variables, while

Table 1 Variables in the Model

A. Endogenous Variables

<i>CDMB</i>	= Monetary Authority's Claims on Deposit Money Banks
<i>DCKB</i>	= Deposit Money Banks' Domestic Credits to the Private Sector
<i>DINVR</i>	= Increase in Real Stocks
<i>GNPR</i>	= Real Gross National Product
<i>IPRR</i>	= Real Private Fixed Investments
<i>ITOTR</i>	= Real Total Investments
<i>MR</i>	= Real Peso Imports
<i>MRS</i> ¹	= Real Dollar Imports
<i>NCGMA</i>	= Monetary Authority's Net Claims on Government
<i>NDAMA</i>	= Monetary Authority's Net Domestic Assets

<i>NFA</i>	= Monetary System's Net Foreign Assets
<i>NFADMB</i>	= Deposit Money Banks' Net Foreign Assets
<i>NFAMA</i>	= Monetary Authority's Net Foreign Assets
<i>PCER</i>	= Real Personal Consumption Expenditures
<i>PGNP</i> ²	= GNP Deflator
<i>RES</i>	= Total Reserves
<i>RM</i>	= Reserve Money
<i>RR</i>	= Required Reserves
<i>TL</i>	= Total Liquidity
<i>TN</i>	= Total Nominal Tax Revenues

B. Exogenous Variables

<i>COTB</i> ³	= Monetary Authority's Claims on Other Banks
<i>DISC</i> ³	= Monetary Authority's Discount Rate
<i>DK</i>	= Net Other Items, BOP
<i>ER</i> ³	= Peso-dollar Exchange Rate
<i>GCER</i> ³	= Real Government Consumption Expenditures
<i>IPUR</i>	= Real Public Fixed Investments
<i>NFI</i>	= Net Factor Incomes from Abroad
<i>NOA</i>	= Net Other Assets [includes capital accounts and Central Bank Certificates of Indebtedness (<i>CBCI</i>)]
<i>NUAMA</i>	= Monetary Authority's Net Unclassified Assets
<i>PEX</i> ²	= Exports Deflator
<i>PGCE</i> ²	= Government Consumption Expenditure Deflator
<i>PIM</i> ²	= Imports Deflator
<i>RDS</i> ³	= Rate on Deposit Substitutes
<i>T</i>	= Time
<i>XR</i>	= Real Exports
<i>USPR</i>	= U. S. Prime Rate

1 In million dollars; all other variables are in million pesos.

2 1972=1.00

3 Policy Variable

the inter-relationships among these variables are presented in the block diagram of Fig. 1.

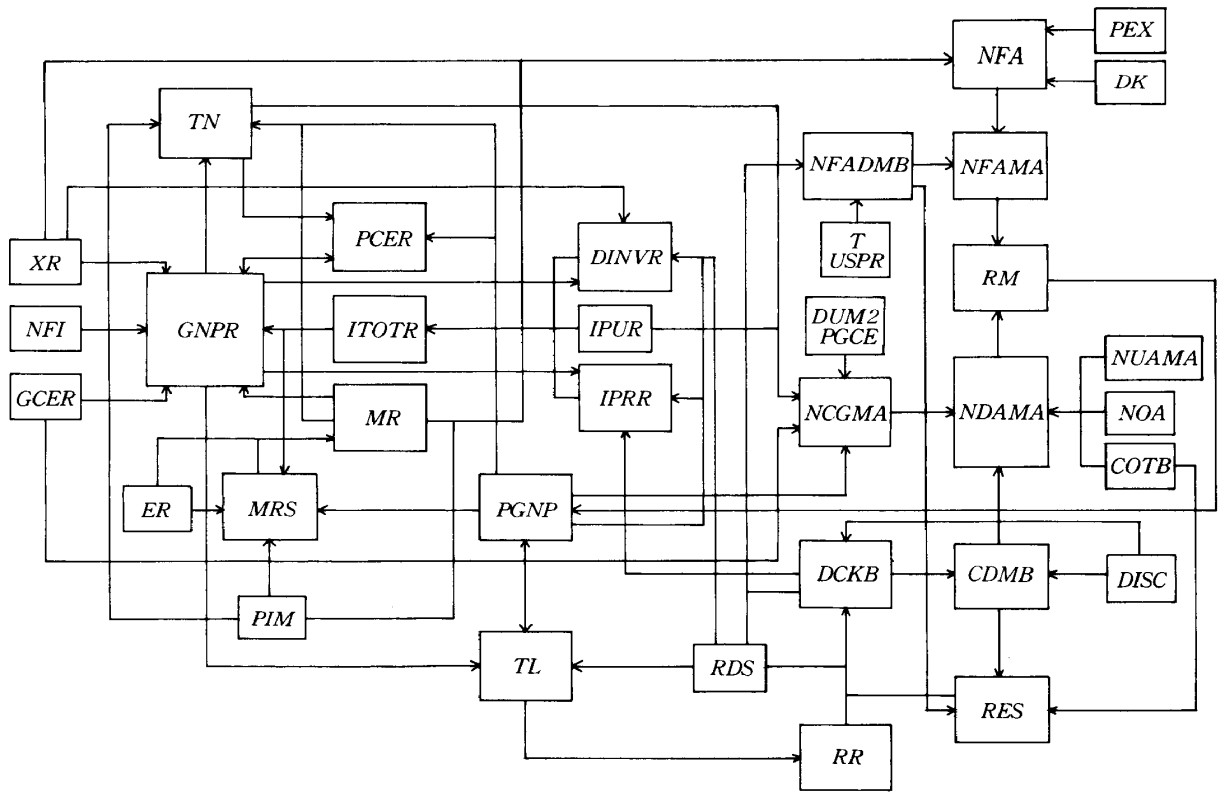

Fig. 1 Block Diagram of the Philippine Model

II Model Specification

1. Real and External Sector

Private Consumption: Real consumption expenditures by the private sector are postulated primarily to depend on real disposable permanent income to take into consideration a longer time horizon in the planning of consumer spending. This specification implies that real private consumption is explained by real current disposable income and the lagged value of real private consumption. Thus, it is of the form:

$$PCER = f(GNPR - TN/PGNP, PCER_{-1})$$

Nominal Taxes: Nominal taxes are influenced by nominal income. Moreover, considering that the National Government relies

on import duties for a sizeable portion of its tax revenues, taxes are also made to depend on the volume of imports. The tax function is of the form:

$$TN = f(GNPR \times PGNP, MR \times PIM)$$

Private Fixed Investments: Real private investments in construction and durable equipment are hypothesized to be influenced by an activity variable (real GNP), a credit availability variable and a price variable, that is:

$$IPRR = f(GNPR, PGNP, DCKB/PGNP)$$

Investment in Stocks: Changes in real inventory accumulation are regarded as dependent on the level of economic activity and the level of exports, the latter representing realized sales. The inclusion of exports

implies that inventory goods in the Philippines consist chiefly of export goods. Changes in inventory goods are also assumed to depend on the level of prices and on a cost constraint, the real short-term interest rate:

$$DINVR = f(GNPR - XR, XR, PGNP, RDS - (PGNP - PGNP_{-1}) / PGNP_{-1})$$

The sign of the coefficient for exports (XR) is expected to be negative, as increases in XR are expected to deplete stocks.

Volume of Imports: Imports in constant dollars are postulated to depend on real total investments and on relative prices (i. e., the foreign exchange rate and the ratio of domestic and import prices. The import function is of the form:

$$MRS = f(ITOTR, PGNP / PIM, ER)$$

Prices: The price equation is formulated according to an inventory scheme theory applied to the money market equilibrium framework. Prices are not expected to change if the ratio of the demand for and the supply of liquidity maintains a certain equilibrium. Adjustment lags are included. Thus,

$$PGNP = f(TL / RM, PGNP_{-1})$$

The demand for liquidity is here represented by nominal liquidity (TL). On the other hand, the supply of liquidity is proxied by reserve money. This is on the assumption that the supply of nominal liquidity basically depends on the level of reserve money so that liquidity movements reflect parallel changes in reserve money.

2. Financial Sector

Demand for Total Liquidity: The demand

for nominal total liquidity is postulated to be influenced by transactional requirements and by the opportunity cost of holding liquid balances. Thus, the right-hand variables include nominal income and the nominal rate of interest on deposit substitutes. Moreover, the non-instantaneous adjustment of actual to desired holdings of liquidity is incorporated through the addition of the lagged value of liquidity.

$$TL = f(PGNP \times GNPR, RDS, TL_{-1})$$

It is to be noted that the sign of the nominal interest rate coefficient becomes an empirical question. The total liquidity concept includes deposit substitutes so that the sign will depend on the relative sizes of the interest elasticities of the different components of total liquidity; i. e., currency, demand, savings and time deposits, and deposit substitutes.

Domestic Credits of Deposit Money Banks to the Private Sector: The supply of domestic credits of the deposit money banks³⁾ to the private sector is determined by the level of excess reserves, which act to induce or deter their expansion. Likewise, the rate differential between the commercial rate of interest and official discount rate influences banks' decisions to increase the credit supply. A lagged adjustment process is also included to capture the time lags from the time of the loan application to the processing and release of the loans. The equation is thus of the form:

$$DCKB = f(RES - RR, RDS - DISC, DCKB_{-1})$$

3) Deposit money banks consist of commercial and rural banks accepting demand deposits.

Claims on Deposit Money Banks by Central Bank: Central Bank's claims on deposit money banks are postulated to depend basically on cost considerations; in this case, on the discount rate of Central Bank. Deposit money banks' demand for loans from Central Bank is likewise influenced by their supply of credit to the private sector. The previous value of loans to deposit money banks is included to capture lags in adjustment of actual to desired magnitudes. The equation is presented in the following form:

$$CDMB=f(DISC, DCKB, CDMB_{-1})$$

Total Reserves: Total reserves are determined by the level of claims of the Monetary Authority on all types of banks and by the net foreign assets of deposit money banks:

$$RES=f(NFADMB, COTB + CDMB)$$

Required Reserves: Due to the unavailability of certain data needed to construct a definitional identity for required reserves, a behavioral equation is utilized which posits required reserves as a function of total liquidity and its lagged value. Thus,

$$RR=f(TL, RR_{-1})$$

Net Claims on Government of Monetary Authorities: Central Bank's net claims on government are postulated to depend on government revenues, nominal taxes, and its consumption and investment expenditures:

$$NCGMA=f(TN, PGCE \times GCER + PGNP \times IPUR)$$

Deposit Money Banks' Net Foreign Assets: The inflow of capital depends partly on the existing relationship between the domestic rate of interest and foreign interest rate, here represented by the U.S. prime rate. It is

likewise affected by changes in the deposit money banks' supply of loans. The function is of the form:

$$NFADMB=f(DCKB - DCKB_{-1}, RDS/USPR)$$

Finally, identities are utilized to close the system. Table 2 presents the complete system, with distinction between behavioral equations and identities.

Table 2 Estimated Equations

I. Behavioral Equations

1. Real Personal Consumption Expenditures

$$PCER = 2765.5313 + 0.1535(0.98) (GNPR - TN/PGNP) + 0.7731PCER_{-1} (3.19)$$

$$R^2=0.9956 \quad S. E.=409.9272 \quad D. W.=1.4991$$

2. Total Nominal Tax Revenues

$$TN = -264.2215 + 0.07748(0.34) (1.54) (GNPR \times PGNP) + 0.2461(MR \times PIM) (1.27)$$

$$R^2=0.9829 \quad S. E.=937.2996 \quad D. W.=1.4654$$

3. Real Private Fixed Investments

$$IPRR = 459.9211 + 0.1304GNPR (0.39) (5.96) - 6980.8418(PGNP (2.17) - PGNP_{-1}) + 0.3053(0.72) (DCKB_{-1}/PGNP_{-1} - DCKB_{-2}/PGNP_{-2})$$

$$R^2=0.7858 \quad S. E.=784.2349 \quad D. W.=1.3852$$

4. Increase in Real Stocks

$$DINVR = -1603.3395 + 0.1605(1.55) (4.20) (GNPR - XR) - 0.1982XR (3.47) - 870.1892PGNP (1.01) - 52.3838[RDS - ((PGNP (4.27) - PGNP_{-1})/PGNP_{-1}) \times 100]$$

$$R^2=0.9612 \quad S. E.=188.4658 \quad D. W.=2.9101$$

Table 2 (Continued)

5. Real Dollar Imports

$$\begin{aligned} MRS &= 3133.5322 + 0.09045ITOTR \\ &\quad (4.66) \quad (13.56) \\ &\quad + 258.2171(PGNP/PIM) \\ &\quad \quad (0.72) \\ &\quad - 437.7877ER \\ &\quad \quad (8.29) \end{aligned}$$

$$R^2=0.9777 \quad S. E.=68.4844 \quad D. W.=1.7009$$

6. GNP Deflator

$$\begin{aligned} \text{Log } PGNP &= 0.06297 + 0.01205 \\ &\quad (0.30) \quad (0.069) \\ &\quad (\text{Log } TL - \text{Log } RM) \\ &\quad + 1.0002(\text{Log}(PGNP_{-1})) \\ &\quad \quad (12.39) \\ &\quad + 0.1383(DUM3) \\ &\quad \quad (3.92) \end{aligned}$$

$$R^2=0.9908 \quad S. E.=0.04091 \quad D. W.=2.1522$$

7. Nominal Total Liquidity

$$\begin{aligned} TL &= 4900.4849 + 0.06729 \\ &\quad (2.45) \quad (1.20) \\ &\quad (PGNP \times GNPR) \\ &\quad - 140.2775RDS \\ &\quad \quad (1.62) \\ &\quad + 0.8400TL_{-1} \\ &\quad \quad (4.50) \\ &\quad - 4131.4028DUM1 \\ &\quad \quad (3.24) \end{aligned}$$

$$R^2=0.9979 \quad S. E.=696.1565 \quad D. W.=2.3805$$

8. Deposit Money Banks' Domestic Credits to the Private Sector

$$\begin{aligned} DCKB &= 758.4995 + 3.4423(RES - RR) \\ &\quad (0.79) \quad (2.05) \\ &\quad + 344.1457(RDS - DISC) \\ &\quad \quad (2.10) \\ &\quad + 0.9533DCKB_{-1} \\ &\quad \quad (8.51) \end{aligned}$$

$$R^2=0.9834 \quad S. E.=1828.6025 \quad D. W.=2.6448$$

9. Monetary Authority's Claims on Deposit Money Banks

$$\begin{aligned} CDMB &= 1230.0018 + 0.4409CDMB_{-1} \\ &\quad (2.61) \quad (2.79) \\ &\quad - 689.0808(DISC - DISC_{-1}) \\ &\quad \quad (3.76) \\ &\quad + 0.02883(DCKB - DCKB_{-1}) \\ &\quad \quad (0.31) \end{aligned}$$

$$R^2=0.7646 \quad S. E.=843.9425 \quad D. W.=1.5990$$

10. Total Reserves

$$\begin{aligned} RES &= 570.5608 - 0.3230NFADMB \\ &\quad (3.95) \quad (6.79) \\ &\quad + 0.1197(COTB + CDMB) \\ &\quad \quad (2.41) \end{aligned}$$

$$R^2=0.9439 \quad S. E.=249.9541 \quad D. W.=2.6005$$

11. Required Reserves

$$\begin{aligned} RR &= 264.4775 + 0.09949(TL - TL_{-1}) \\ &\quad (2.02) \quad (2.30) \\ &\quad + 0.4453RR_{-1} \\ &\quad \quad (2.09) \end{aligned}$$

$$R^2=0.8400 \quad S. E.=242.3349 \quad D. W.=2.2815$$

12. Monetary Authority's Net Claims on Government

$$\begin{aligned} NCGMA &= 1755.2690 - 0.3406TN \\ &\quad (6.95) \quad (3.46) \\ &\quad + 0.2884(PGCE \times GCER) \\ &\quad \quad (4.54) \\ &\quad + PGNP \times IPUR \\ &\quad - 1531.5289DUM2 \\ &\quad \quad (2.93) \end{aligned}$$

$$R^2=0.8809 \quad S. E.=410.7645 \quad D. W.=0.9279$$

13. Deposit Money Banks' Net Foreign Assets

$$\begin{aligned} NFADMB &= 693.1914 - 0.1149 \\ &\quad (0.90) \quad (0.77) \\ &\quad (DCKB - DCKB_{-1}) - 615.9743T \\ &\quad \quad (4.31) \\ &\quad + 1044.6125(RDS/USPR) \\ &\quad \quad (2.09) \end{aligned}$$

$$R^2=0.8736 \quad S. E.=878.1174 \quad D. W.=1.2497$$

II. Identities

A. Real/External Sector

14. Real Total Investments

$$ITOTR = IPRR + IPUR + DINVR$$

15. Income Identity

$$\begin{aligned} GNPR &= PCER + GCER + ITOTR \\ &\quad + XR - MR + NFI \end{aligned}$$

16. Real Peso Imports

$$MR = MRS \times ER$$

B. Financial Sector

17. Monetary System's Net Foreign Assets

$$\begin{aligned} NFA &= XR \times PEX - MR \times PIM \\ &\quad + DK + NFA_{-1} \end{aligned}$$

18. Monetary Authority's Net Foreign Assets

$$NFAMA = NFA - NFADMB$$

19. Monetary Authority's Net Domestic Assets

$$\begin{aligned} NDAMA &= CDMB + COTB + NCGMA \\ &\quad + NUAMA + NOA \end{aligned}$$

20. Reserve Money

$$RM = NFAMA + NDAMA$$

III Estimation

The equations were estimated by using annual data from 1967 to 1978.⁴⁾ Data for the real sector were obtained from the National Economic and Development Authority (NEDA) and those for the monetary sector came from Central Bank of the Philippines (CBP).

Each equation was estimated by using the ordinary least squares method (OLS). Table 2 lists each of the estimated equations along with the adjusted value of the multiple coefficient of determination (R^2), the Durbin-Watson statistic ($D.W.$), and the standard error of estimate ($S.E.$). T-statistics for each coefficient are listed in parentheses below the coefficients.

IV Results/Findings

The consumption function is patterned after the permanent income hypothesis approximated by a geometric lag distribution. The short-run marginal propensity to consume (MPC) is estimated at 0.15, while the long-run MPC is given by $0.1535/(1-0.7731)$ or approximately 0.68, consistent with what is expected of a developing country. Further, that the short-run MPC is less than the long-run MPC verifies the results of major studies on the consumption function.

Based on the t-statistics, nominal tax revenues depend almost equally on both nominal income and imports. Both variables account for 98.3 percent of the variation in the

4) The latest figures were not accessible at the time of writing of this paper.

dependent variable.

On the basis of correct signs for the estimated coefficients, the final form of the equation for fixed investments was chosen among several other regression runs using various forms for the independent variables.⁵⁾ As expected, the fixed investments equation indicates that real income has a highly significant effect on real private fixed investments; the marginal propensity to invest is 0.13.

The change in the level of prices likewise has a significant impact on investments such that a one index point increase in prices is expected to result in a 6981 million decrease in investments. Although the credit availability variable is not significant, it has been retained in the equation because of *a priori* belief that credits provide a link between the real and financial sectors; in this case, the

5) Some alternative forms are reproduced here for reference.

$$1. \quad IPRR = 2798.46835 + 0.01409 \text{ GNPR} \\ \quad \quad \quad (1.09) \quad \quad \quad (0.12) \\ \quad \quad \quad - 6201.47543(PGNP - PGNP_{-1}) \\ \quad \quad \quad (2.16) \\ \quad \quad \quad + 0.34696(DCKB/PGNP) \\ \quad \quad \quad (1.05) \\ \quad \quad \quad R^2 = 0.799 \quad S.E. = 759.63834 \\ \quad \quad \quad D.W. = 1.28$$

$$2. \quad IPRR = 8356.22095 - 0.05844 \text{ GNPR} \\ \quad \quad \quad (2.59) \quad \quad \quad (0.76) \\ \quad \quad \quad - 4696.13372(PGNP - PGNP_{-1}) \\ \quad \quad \quad (2.02) \\ \quad \quad \quad + 0.17484 \text{ DCKB} \\ \quad \quad \quad (2.56) \\ \quad \quad \quad R^2 = 0.875 \quad S.E. = 600.06336 \\ \quad \quad \quad D.W. = 1.35$$

$$3. \quad IPRR = 6430.04445 - 0.20652 \text{ GNPR} \\ \quad \quad \quad (4.47) \quad \quad \quad (2.78) \\ \quad \quad \quad - 3900.95860(PGNP - PGNP_{-1}) \\ \quad \quad \quad (2.35) \\ \quad \quad \quad + 1.11479(DCKB_{-1}/PGNP_{-1}) \\ \quad \quad \quad (4.65) \\ \quad \quad \quad R^2 = 0.938 \quad S.E. = 420.82324 \\ \quad \quad \quad D.W. = 1.80$$

link between monetary policy and investments.

The estimated equation for increases in real stocks seems to support the assumption that inventory goods in the Philippines are primarily geared toward the exports market. The level of real income less exports and real exports both highly affect movements in the dependent variable. Also, the real rate of interest, which is one of the monetary-real linkages in the model, provides a very good explanation for changes in real stock.⁶⁾

6) It was only after experimental estimations of many other alternative specifications that this finally satisfactory equation was obtained. For the reader's convenience, some alternative forms are shown here:

1. $DINVR = -813.1023 + 0.12942(GNPR$
 $(0.72) \quad (3.03)$
 $-XR) - 0.20750 XR$
 (2.29)
 $-429.2566 PGNP$
 (0.43)
 $-54.62132 RDS - ((PGNP$
 (3.69)
 $-PGNP_{-1})/PGNP_{-1}) \times 100$
 $+0.09336 DINVR_{-1}$
 (0.41)
 $R^2 = 0.944 \quad S. E. = 226.75617$
 $D. W. = 2.77$
2. $DINVR = -1476.86101 + 0.16911(GNPR$
 $(0.79) \quad (2.36)$
 $-XR) - 0.15291 XR$
 (1.32)
 $-542.4909 PGNP$
 (0.34)
 $-0.08838(DCTMS/PGNP),$
 (0.87)
 where $DCTMS =$ Domestic Credit of Total Monetary System.
 $R^2 = 0.874 \quad S. E. = 339.97901$
 $D. W. = 2.20$
3. $DINVR = -2920.01851 + 0.15671(GNPR$
 $(2.26) \quad (3.54)$
 $-XR) - 0.0024 XR$
 (0.03)
 $-2113.30503 PGNP$
 (2.00)
 $+77.72147 RDS$
 (3.43)
 $R^2 = 0.948 \quad S. E. = 218.76756$
 $D. W. = 2.77$

The imports equation indicates that total imports respond significantly to gross investments, because the bulk of the country's imports are capital goods. Likewise, the low t-statistics for the relative price ratio is as expected. This implies the lack of substitutability between imported and domestic goods which actually prevails in the Philippine economy.

For the price equation, various alternative forms were attempted⁷⁾ after which the log form was finally chosen not only because it yielded the best statistical results but also because some others did not lead to convergence for the model. A dummy variable is included to represent the extraordinarily high increases in prices that occurred in 1973 and 1974 as a result of oil shocks:

$$DUM3 = 1 \text{ for } 1973 \text{ and } 1974$$

$$= 0 \text{ otherwise.}$$

- 7) 1. $PGNP = 0.18860 - 0.44225(RM/TL)$
 $(0.55) \quad (0.55)$
 $+1.03221 PGNP_{-1}$
 (11.2)
 $+0.16579 DUM3$
 (3.16)
 $R^2 = 0.99 \quad S. E. = 0.05188$
 $D. W. = 2.65$
2. $LN(PGNP) = 0.06298 - 0.01205(LN(RM)$
 $(0.30) \quad (0.07)$
 $-LN(TL))$
 $+1.00029LN(PGNP_{-1})$
 (12.39)
 $+0.13832 DUM3$
 (3.93)
 $R^2 = 0.991 \quad S. E. = 0.04092$
 $D. W. = 2.15$
3. $PGNP = -0.09165 + 0.04869(TL/RM)$
 $(0.66) \quad (0.70)$
 $+1.01345 PGNP_{-1}$
 (10.12)
 $+0.16515 DUM3$
 (3.42)
 $R^2 = 0.991 \quad S. E. = 0.05131$
 $D. W. = 2.63$

On the financial side, a dummy variable⁸⁾ is included in the demand for total liquidity for the period in which the deposit substitutes (money market paper) emerged but no data have been compiled.

Total domestic credits of the deposit money banks to the private sector (*DCKB*) is one of the intermediate targets of Central Bank operations. It provides one of the major links between the real and money sectors. Changes in the level of domestic credits are primarily influenced by the level of excess reserves such that a ₱ 1 million increase in these reserves will lead to a ₱ 3.4 million credit expansion. Likewise, a one-percent increase in interest rate differential between the commercial rate of interest and Central Bank discount rate will lead to an expansion of ₱ 344 million in credits.⁹⁾

8) $DUMI = 1$ for 1967 to 1972
 $= 0$ otherwise

9) This calculation is based on the final form for *DCKB* which was chosen among several alternative specifications as follows:

1. $DCKB = -225.67631 + 2.07490 RES$
(0.24) (0.69)
 $+ 0.77399 TL$
(3.77)
 $R^2 = 0.990$ $S.E. = 1406.71822$
 $D.W. = 1.76$
2. $DCKB = -4712.11311 + 18.06712(RES$
(0.90) (5.45)
 $- RR) + 1119.86045 RDS$
(2.83)
 $R^2 = 0.797$ $S.E. = 6403.19964$
 $D.W. = 1.51$
3. $DCKB = -1696.50702 + 3.43555(RES$
(3.16) (5.11)
 $- RR) - 127.28340(RDS - DISC)$
(1.31)
 $+ 25923.67558(PGNP - PGNP_{-1})$
(6.54)
 $+ 1.03868 DCKB_{-1}$
(22.21)
 $R^2 = 0.997$ $S.E. = 433.46188$
 $D.W. = 2.37$

The Monetary Authority's claims on deposit money banks (*CDMB*) is regarded as depending on the change in the discount rate and the increment of deposit money banks' domestic credits to the private sector (*DCKB*). This form was chosen on statistical bases among various alternative forms.¹⁰⁾

The estimated equation reveals the strong influence of monetary policy in controlling the level of *CDMB* through Central Bank discount rate. The relationship thus provides one of the channels by which the impact of changes in monetary policy may be transmitted to the entire economy.

Total reserves of deposit money banks are influenced by the claims of the Monetary Authority on the banking institutions and by deposit money banks' assets. Required reserves, on the other hand, are chiefly affected by changes in, rather than the level

- 10) 1. $CDMB = 264.68731 + 0.30502 CDMB_{-1}$
(0.53) (2.32)
 $- 13.01659(DISC - DISC_{-1})$
(0.04)
 $- 953.80930(PGNP - PGNP_{-1})$
(0.36)
 $+ 0.53599(DCKB_{-1} - DCKB_{-2})$
(2.36)
 $R^2 = 0.864$ $S.E. = 640.60446$
 $D.W. = 1.99$
2. $CDMB = 2706.38757 + 0.41615 CDMB_{-1}$
(1.15) (1.42)
 $- 227.58166 DISC$
(0.96)
 $+ 0.13689(DCKB - DCKB_{-1})$
(1.02)
 $R^2 = 0.415$ $S.E. = 1330.78166$
 $D.W. = 1.54$
3. $CDMB = 1311.50501 + 0.45068 CDMB_{-1}$
(2.55) (2.13)
 $- 710.89662(DISC - DISC_{-1})$
(3.39)
 $+ 0.00008 DCKB$
—
 $R^2 = 0.762$ $S.E. = 849.25919$
 $D.W. = 1.72$

of, total liquidity; a P 1 million increase in total liquidity from the previous period will add P 0.10 million in reserves.

A dummy variable¹¹⁾ was included in the equation for Monetary Authority's net claims on government. This is to account for the highly contractionary position assumed by the government in 1974 to contain the excess liquidity spilled over from the foreign sector as a result of the commodity boom in 1973.

Finally, for the equation for net foreign assets of deposit money banks, the time factor was included to capture the strong downward movements in the other variables not identified in the equation.

V Evaluation of the Model: Ex-post or Historical Simulation

The validity of an econometric model depends on its ability to replicate the actual data. Thus, a dynamic simulation was applied to the complete system and within sample estimates of the endogenous variables were generated.

The actual values of endogenous and exogenous variables from 1967 to 1978 are shown in Data Appendix, and the graphs of the actual and simulated values for endogenous variables are presented in Figs. 2. 1 to 2. 12. The solid lines plot the actual values while the dotted lines show the simulated values. The variables chosen are those with large root mean square (*RMS*) percent errors¹²⁾ of the endogenous variables, the more

common quantitative measure of the predictive capability of an econometric model. They are presented in Table 3 in order of increasing magnitude.

The simulation results show that the model has reproduced the time paths of the real sector variables rather closely compared to those of the external and monetary sector variables.

In the monetary sector, the actual values of the variables Monetary Authority's claims on deposit money banks (*CDMB*) and Monetary Authority's net claims on government (*NCGMA*) were underestimated from 1967 to 1971; in addition, *CDMB* failed to pick

Table 3 Root Mean Square Errors

Variables	Root Mean Square (<i>RMS</i>) Percent Error
<i>PCER</i>	0.85
<i>GNPR</i>	1.57
<i>TL</i>	2.48
<i>PGNP</i>	3.22
<i>MR</i>	4.70
<i>MRS</i>	4.70
<i>DCKB</i>	7.88
<i>ITOTR</i>	7.90
<i>TN</i>	8.88
<i>DINVR</i>	9.69
<i>IPRR</i>	11.26
<i>RR</i>	16.87
<i>RM</i>	23.56
<i>RES</i>	24.86
<i>CDMB</i>	81.42
<i>NCGMA</i>	81.85
<i>NDAMA</i>	91.31
<i>NFA</i>	113.80
<i>NFADMB</i>	142.49
<i>NFAMA</i>	143.93

t,

Y_t^a = actual value of *Y* in period *t*,
N = number of periods in simulation

11) $DUM2 = 1$ for 1974
 = 0 otherwise

12) RMS percent error = $\sqrt{1/N \sum [(Y_t^s - Y_t^a)/Y_t^a]^2}$
 where Y_t^s = simulated value of *Y* in period

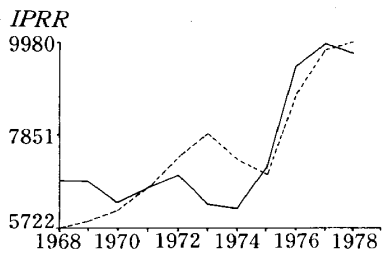

Fig. 2.1 *IPRR*: Real Private Fixed Investments

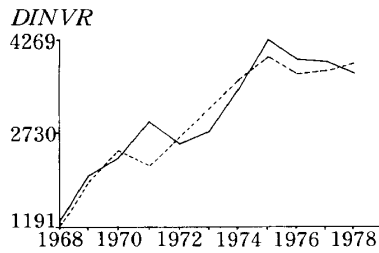

Fig. 2.2 *DINVR*: Increase in Real Stocks

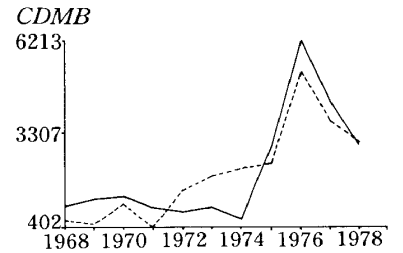

Fig. 2.3 *CDMB*: Monetary Authority's Claims on Deposit Money Banks

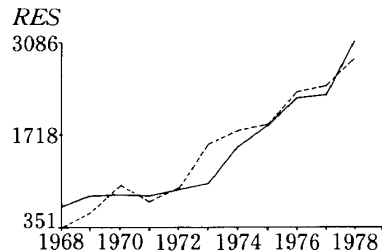

Fig. 2.4 *RES*: Total Reserves

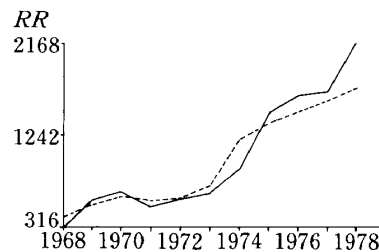

Fig. 2.5 *RR*: Required Reserves

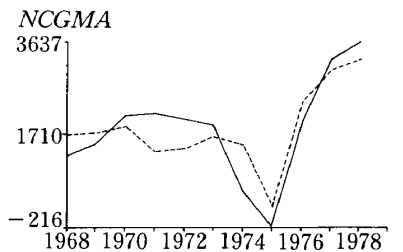

Fig. 2.6 *NCGMA*: Monetary Authority's Net Claims on Government

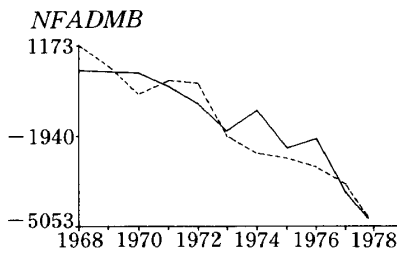

Fig. 2.7 *NFADMB*: Deposit Money Banks' Net Foreign Assets

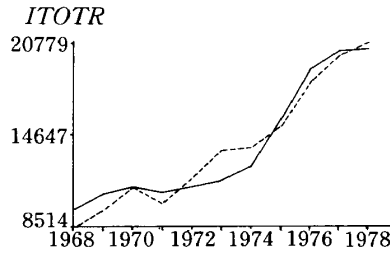

Fig. 2.8 *ITOTR*: Real Total Investments

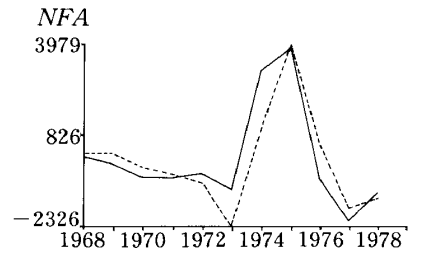

Fig. 2.9 *NFA*: Monetary System's Net Foreign Assets

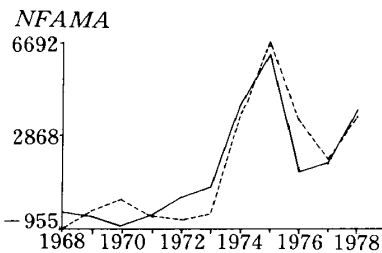

Fig. 2.10 *NFAMA*: Monetary Authority's Net Foreign Assets

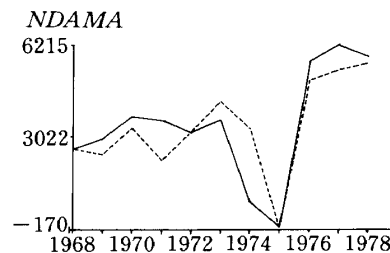

Fig. 2.11 *NDAMA*: Monetary Authority's Net Domestic Assets

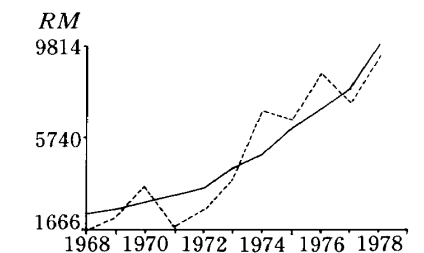

Fig. 2.12 *RM*: Reserve Money

up the downturn in 1973. Consequently, these generated similar errors in the variable Monetary Authority's net domestic assets

(*NDAMA*), which directly depends on both *CDMB* and *NCGMA* through a definitional identity.

On the other hand, for the foreign sector, the errors resulting from the poor simulation performance of deposit money banks' net foreign assets (*NFADMB*) are further transmitted to the other variables such as Monetary System's net foreign assets (*NFA*) and Monetary Authority's net foreign assets (*NFAMA*), which similarly deviate considerably from their respective actual series.

VI Dynamic Multiplier Analysis and Policy Simulation

Notwithstanding some unfavorable ex-post simulation results, policy simulation was performed on the model to find out the time paths of the multiplier effects of alternative policies that appear in the model and to simultaneously test the feasibility of the model's structural properties.

First, a control solution was adopted in the form of the ex-post simulation results. Then, multiplier or "shock" solutions were generated using different autonomous changes which were maintained continuously over the solution period. Multipliers, which summarize the effect of the policy change on each endogenous variable per period, were obtained by normalizing differences between shock and control solution values.¹³⁾

The six different policy experiments under-

13) Multiplier = $m_{ij} = (Y_{ij}^s - Y_{ij}^a) / \Delta PV_k$,
 where m_{ij} = multiplier for j th endogenous variable in year i ,
 Y_{ij}^s = "shocked" value of the j th endogenous variable in year i ,
 Y_{ij}^a = ex-post simulated value of the j th endogenous variable in year i ,
 ΔPV_k = change in policy variable k

taken to generate the multiplier solutions are as follows:

Policy I. A sustained increase in real government consumption expenditures (*GCER*) by ₱ 300 million throughout the entire estimation period;

Policy II. A sustained increase in real public fixed investments by ₱ 300 million throughout the entire estimation period;

Policy III. A sustained increase in real exports by ₱ 300 million from 1967 to 1978;

Policy IV. A sustained increase in Monetary Authority's claims on other banks by ₱ 300 million from 1967 to 1978;

Policy V. A sustained increase in Central Bank's rediscount rate of one percent throughout the entire estimation period; and

Policy VI. A sustained decrease of 22 percent in the import price index throughout the entire estimation period.

The dynamic real income (*GNPR*) multipliers corresponding to the first four policy changes are presented in Table 4. The

Table 4 Real Income (*GNPR*) Multipliers for Changes in Various Exogenous Variables

Year	$\Delta GNPR$ from $\Delta GCER$	$\Delta GNPR$ from $\Delta IPUR$	$\Delta GNPR$ from ΔXR	$\Delta GNPR$ from $\Delta COTB$
1967	1.485	0.942	1.150	0.009
1968	1.713	1.068	1.351	0.252
1969	1.925	1.184	1.548	0.259
1970	1.967	0.931	1.713	0.208
1971	2.057	0.837	1.888	0.198
1972	2.148	0.783	2.047	0.193
1973	2.232	0.732	2.218	0.201
1974	2.316	0.709	2.318	0.126
1975	2.354	0.633	2.370	0.096
1976	2.377	0.536	2.468	0.124
1977	2.419	0.486	2.549	0.107
1978	2.463	0.456	2.615	0.093

Table 5.1 Policy Change: P 300 M Increase in GCER

	<i>CDMB</i>	<i>DCKB</i>	<i>DINVR</i>	<i>GNPR</i>	<i>IPRR</i>	<i>ITOTR</i>	<i>MR</i>
1967	-0.229	-7.922	70.533	445.578	59.004	129.535	45.629
1968	-0.442	-19.746	82.872	513.888	63.679	146.551	51.722
1969	-0.600	-33.789	93.766	577.645	69.492	163.258	57.965
1970	-0.708	-49.152	78.926	590.094	66.445	165.371	89.145
1971	-0.811	-66.446	103.789	617.015	65.602	169.391	101.848
1972	-0.928	-86.223	107.129	644.449	66.137	173.266	110.067
1973	-1.174	-112.738	109.204	669.727	63.847	173.051	112.996
1974	-1.621	-151.024	113.466	694.793	60.441	173.910	114.461
1975	-2.062	-197.832	111.672	706.188	59.207	170.879	122.364
1976	-2.577	-255.653	112.491	713.000	37.195	149.687	114.792
1977	-3.215	-327.754	109.064	725.625	30.692	139.754	111.715
1978	-3.953	-415.707	104.968	738.875	26.890	131.860	109.707
	<i>MRS</i>	<i>NCGMA</i>	<i>NDAMA</i>	<i>NFA</i>	<i>NFADMB</i>	<i>NFAMA</i>	<i>PCER</i>
1967	11.653	57.382	57.153	-24.643	0.911	-25.554	61.680
1968	13.208	55.418	54.976	-52.126	1.360	-53.485	119.000
1969	14.790	53.421	52.821	-82.651	1.615	-84.266	172.355
1970	15.206	51.675	50.965	-156.144	1.766	-157.911	213.875
1971	15.835	56.122	55.309	-254.259	1.988	-256.247	249.492
1972	16.499	57.794	56.867	-364.326	2.273	-366.599	281.246
1973	16.725	54.671	53.497	-504.441	3.049	-507.489	309.668
1974	16.862	65.545	63.925	-730.111	4.401	-734.512	335.344
1975	16.883	79.410	77.343	-993.385	5.381	-998.766	357.683
1976	15.429	102.834	100.258	-1260.592	6.647	-1267.239	378.129
1977	15.091	107.095	103.878	-1529.432	8.289	-1537.720	397.590
1978	14.895	117.927	113.972	-1808.361	10.113	-1818.472	416.723
	<i>PGNP</i>	<i>RES</i>	<i>RM</i>	<i>RR</i>	<i>TL</i>	<i>TN</i>	
1967	0.000	-0.322	31.599	1.980	19.902	28.983	
1968	-0.000	-0.493	1.491	3.050	41.699	35.526	
1969	0.000	-0.594	-31.445	3.754	65.773	42.915	
1970	0.001	-0.656	-106.945	4.266	91.840	60.219	
1971	0.002	-0.740	-200.938	4.949	122.469	76.351	
1972	0.003	-0.846	-309.732	5.800	158.622	91.266	
1973	0.005	-1.125	-453.992	7.746	210.508	123.441	
1974	0.008	-1.615	-670.586	11.033	286.730	182.074	
1975	0.012	-1.985	-921.421	13.659	374.633	218.821	
1976	0.018	-2.455	-1166.780	17.020	484.574	261.347	
1977	0.022	-3.063	-1433.840	21.346	622.945	314.743	
1978	0.029	-3.739	-1704.503	26.250	791.250	377.164	

Table 5.2 Policy Change: P 300 M Increase in *IPUR*

	<i>CDMB</i>	<i>DCKB</i>	<i>DINVR</i>	<i>GNPR</i>	<i>IPRR</i>	<i>ITOTR</i>	<i>MR</i>
1967	-0.152	-5.281	46.461	282.578	35.813	382.273	135.672
1968	-0.305	-13.512	54.213	320.254	35.765	389.981	139.257
1969	-0.428	-23.169	59.771	355.251	37.906	397.676	143.270
1970	-0.529	-35.527	56.844	279.329	14.453	371.301	203.395
1971	-0.679	-50.953	51.764	251.035	-1.066	350.699	215.563
1972	-0.883	-71.309	44.613	234.797	-9.227	335.387	219.207
1973	-1.249	-101.020	35.371	219.512	-24.750	310.621	210.411
1974	-1.890	-147.493	33.891	212.832	-43.063	290.828	199.145
1975	-2.586	-208.324	21.741	189.875	-46.567	275.176	207.000
1976	-3.502	-290.215	16.090	160.750	-95.898	220.191	182.246
1977	-4.704	-399.824	1.121	145.937	-110.773	190.347	169.821
1978	-6.089	-539.145	-13.860	136.875	-119.149	166.992	160.797
	<i>MRS</i>	<i>NCGMA</i>	<i>NDAMA</i>	<i>NFA</i>	<i>NFADMB</i>	<i>NFAMA</i>	<i>PCER</i>
1967	34.648	47.237	47.085	-73.272	0.607	-73.880	35.976
1968	35.563	50.545	50.241	-147.267	0.947	-148.214	69.532
1969	36.557	53.900	53.479	-222.716	1.180	-223.895	100.781
1970	34.693	50.640	50.110	-390.399	1.352	-391.752	111.422
1971	33.516	51.198	50.518	-598.062	1.773	-599.836	115.890
1972	32.860	55.227	54.347	-817.270	2.340	-819.609	118.492
1973	31.144	67.572	66.312	-1078.718	3.416	-1081.594	119.531
1974	29.338	82.307	80.417	-1470.809	5.342	-1476.153	121.148
1975	28.560	95.317	92.738	-1916.185	6.993	-1923.178	121.543
1976	24.495	113.724	110.222	-2340.405	9.415	-2349.819	122.801
1977	22.940	129.206	124.500	-2749.074	12.602	-2761.675	125.449
1978	21.831	157.428	151.336	-3157.897	16.019	-3173.914	130.691
	<i>PGNP</i>	<i>RES</i>	<i>RM</i>	<i>RR</i>	<i>TL</i>	<i>TN</i>	
1967	0.000	-0.214	-26.795	1.320	13.277	33.322	
1968	0.001	-0.343	-97.972	2.121	28.679	38.395	
1969	0.001	-0.431	-170.416	2.733	46.613	44.496	
1970	0.004	-0.501	-341.640	3.237	66.891	73.223	
1971	0.007	-0.656	-549.318	4.307	95.621	96.554	
1972	0.010	-0.857	-765.262	5.747	134.231	115.782	
1973	0.015	-1.257	-1015.281	8.341	192.437	156.035	
1974	0.023	-1.952	-1395.734	12.917	284.930	238.574	
1975	0.031	-2.566	-1830.441	17.104	398.875	293.371	
1976	0.042	-3.459	-2239.598	23.151	555.035	357.683	
1977	0.053	-4.634	-2637.172	31.139	764.418	443.926	
1978	0.066	-5.902	-3022.578	39.985	1026.938	543.687	

Table 5.3 Policy Change: P 300 M Increase in XR

	<i>CDMB</i>	<i>DCKB</i>	<i>DINVR</i>	<i>GNPR</i>	<i>IPRR</i>	<i>ITOTR</i>	<i>MR</i>
1967	-0.158	-5.481	-57.353	345.121	49.750	-7.605	-3.976
1968	-0.272	-12.484	-49.681	405.445	61.113	11.434	0.500
1969	-0.314	-19.216	-38.554	464.332	70.312	31.758	5.203
1970	-0.211	-21.734	-42.703	513.766	95.715	53.016	15.297
1971	0.022	-18.125	-28.669	566.316	118.574	89.907	35.161
1972	0.328	-7.062	-14.717	614.203	130.152	115.434	43.071
1973	0.737	13.164	2.059	665.407	157.304	159.363	65.621
1974	1.329	47.988	10.308	695.508	182.340	192.649	89.207
1975	2.031	97.750	23.983	710.938	176.472	200.457	96.340
1976	2.910	167.617	32.880	740.250	217.738	250.617	126.480
1977	4.025	262.699	48.930	764.687	225.477	274.406	134.219
1978	5.258	383.460	64.601	784.562	232.925	297.528	142.676
	<i>MRS</i>	<i>NCGMA</i>	<i>NDAMA</i>	<i>NFA</i>	<i>NFADMA</i>	<i>NFAMA</i>	<i>PCER</i>
1967	-1.015	-5.533	-5.691	155.128	0.603	154.497	48.758
1968	0.127	-6.653	-6.924	320.773	0.806	319.968	94.512
1969	1.328	-8.249	-8.563	486.136	0.774	485.362	137.785
1970	2.609	-6.105	-6.317	751.258	0.290	750.967	176.055
1971	5.467	-6.752	-6.675	1026.550	-0.415	1026.570	210.304
1972	6.456	-7.791	-7.465	1283.085	-1.272	1284.357	241.832
1973	9.713	-10.584	-9.843	1624.240	-2.325	1626.563	271.465
1974	13.142	-26.868	-25.538	2117.678	-4.004	2121.683	292.063
1975	13.292	-40.744	-38.692	2551.697	-5.721	2551.417	306.335
1976	17.000	-55.755	-52.844	2841.846	-8.032	2849.876	316.094
1977	18.131	-62.032	-58.008	3142.969	-10.929	3153.887	324.500
1978	19.371	-84.221	-78.965	3458.903	-13.883	3472.789	329.680
	<i>PGNP</i>	<i>RES</i>	<i>RM</i>	<i>RR</i>	<i>TL</i>	<i>TN</i>	
1967	-0.000	-0.223	148.806	1.369	13.762	15.318	
1968	-0.002	-0.293	313.043	1.816	25.886	16.561	
1969	-0.003	-0.288	476.798	1.837	36.215	17.334	
1970	-0.007	-0.118	744.651	0.874	36.805	10.437	
1971	-0.011	0.149	1019.896	-0.604	26.141	2.964	
1972	-0.016	0.450	1276.889	-2.518	3.539	-10.609	
1973	-0.022	0.850	1616.719	-4.930	-34.477	-23.649	
1974	-0.033	1.452	2096.144	-8.842	-101.293	-39.984	
1975	-0.040	2.104	2518.727	-13.001	-192.441	-73.125	
1976	-0.051	2.943	2797.035	-18.678	-322.000	-112.153	
1977	-0.063	4.012	3095.883	-25.879	-498.523	-183.098	
1978	-0.074	5.114	3393.824	-33.526	-719.660	-251.157	

Table 5.4 Policy Change: P 300 M Increase in *COTB*

	<i>CDMB</i>	<i>DCKB</i>	<i>DINVR</i>	<i>GNPR</i>	<i>IPRR</i>	<i>ITOTR</i>	<i>MR</i>
1967	4.190	145.305	-10.473	2.660	10.461	-0.012	-2.722
1968	5.854	284.235	5.625	75.750	89.665	95.293	28.589
1969	6.419	417.309	10.181	77.625	73.805	83.985	22.699
1970	6.548	546.235	4.836	62.543	67.761	72.598	28.395
1971	6.499	671.461	9.024	59.488	59.516	68.539	27.739
1972	6.365	792.836	12.380	57.887	50.883	63.262	23.868
1973	6.249	912.199	16.504	60.286	52.519	69.024	27.051
1974	6.217	1032.234	15.600	37.699	13.015	28.617	5.149
1975	6.160	1150.715	16.342	28.250	0.308	16.632	-2.711
1976	6.064	1266.824	19.613	31.250	34.949	54.562	22.261
1977	5.990	1381.824	20.921	32.062	26.532	47.449	16.379
1978	5.926	1495.589	22.277	28.000	23.047	45.324	14.266
	<i>MRS</i>	<i>NCGMA</i>	<i>NDAMA</i>	<i>NFA</i>	<i>NFADMB</i>	<i>NFAMA</i>	<i>PCER</i>
1967	-0.695	1.015	305.205	1.471	-16.705	18.175	-0.051
1968	7.301	-1.024	304.830	-13.721	-15.971	2.251	9.047
1969	5.791	-0.750	305.669	-25.674	-15.298	-10.376	16.343
1970	4.844	1.731	308.279	-49.083	-14.822	-34.262	18.344
1971	4.313	2.561	309.060	-75.805	-14.396	-61.409	18.695
1972	3.578	2.819	309.983	-99.673	-13.954	-85.719	18.492
1973	4.004	3.662	309.914	-133.215	-13.722	-119.493	18.309
1974	0.759	4.247	310.464	-143.366	-13.800	-129.567	14.227
1975	-0.374	1.922	308.078	-137.534	-13.621	-123.912	9.375
1976	2.993	-5.012	301.051	-189.353	-13.348	-176.005	4.965
1977	2.212	-3.913	302.078	-228.769	-13.222	-215.545	1.004
1978	1.937	-7.850	298.070	-265.038	-13.079	-251.961	-3.074
	<i>PGNP</i>	<i>RES</i>	<i>RM</i>	<i>RR</i>	<i>TL</i>	<i>TN</i>	
1967	-0.001	41.814	323.380	-0.396	-3.977	-4.941	
1968	-0.003	41.777	307.051	-0.549	-7.423	-1.309	
1969	-0.004	41.627	295.293	-0.881	-14.121	-5.843	
1970	-0.005	41.489	274.017	-1.617	-26.414	-10.996	
1971	-0.007	41.346	247.652	-2.431	-43.597	-18.075	
1972	-0.009	41.186	223.464	-3.168	-64.554	-26.285	
1973	-0.011	41.078	190.418	-4.316	-93.750	-37.250	
1974	-0.014	41.119	180.898	-6.107	-135.824	-63.207	
1975	-0.015	41.054	184.164	-7.346	-182.320	-79.976	
1976	-0.017	40.955	125.047	-8.363	-233.489	-79.731	
1977	-0.020	40.904	86.535	-9.662	-293.168	-102.023	
1978	-0.021	40.851	46.110	-10.917	-359.648	-121.614	

Table 5.5 Policy Change: 1% Increase in DISC

	<i>CDMB</i>	<i>DCKB</i>	<i>DINVR</i>	<i>GNPR</i>	<i>IPRR</i>	<i>ITOTR</i>	<i>MR</i>
1967	-11.545	-400.356	2.095	-0.535	-2.093	0.000	0.543
1968	-15.988	-778.242	-27.816	-172.918	-204.660	-232.476	-81.688
1969	-17.353	-1135.547	-27.001	-162.930	-165.082	-192.082	-67.547
1970	-17.410	-1473.929	-21.385	-111.507	-126.106	-147.488	-78.679
1971	-16.899	-1794.110	-16.321	-87.067	-89.820	-106.140	-61.226
1972	-16.155	-2095.914	-13.751	-71.566	-67.141	-80.894	-51.726
1973	-15.298	-2379.375	-10.200	-58.894	-46.743	-56.945	-38.506
1974	-14.446	-2646.446	-0.317	-8.234	62.144	61.828	34.504
1975	-13.625	-2898.074	2.479	-3.937	67.480	69.961	42.285
1976	-12.786	-3133.118	-0.927	-26.375	-1.406	-2.332	-5.915
1977	-11.975	-3352.903	0.970	-20.375	7.907	8.875	1.133
1978	-11.211	-3558.586	2.585	-16.188	13.070	15.656	5.305
	<i>MRS</i>	<i>NCGMA</i>	<i>NDAMA</i>	<i>NFA</i>	<i>NFADMB</i>	<i>NFAMA</i>	<i>PCER</i>
1967	0.139	-0.203	-11.747	-0.293	46.026	-46.320	0.008
1968	-20.861	6.761	-9.227	43.112	43.443	-0.332	-22.132
1969	-17.236	6.225	-11.128	78.683	41.077	37.605	-38.395
1970	-13.420	8.185	-9.225	143.548	38.902	104.646	-42.703
1971	-9.519	7.719	-9.125	202.531	36.809	165.722	-43.415
1972	-7.754	7.512	-8.645	254.257	34.696	219.561	-42.399
1973	-5.708	8.028	-7.269	302.080	32.588	269.492	-40.519
1974	5.083	-3.532	-17.978	234.049	30.703	203.347	-35.555
1975	5.835	-6.751	-20.364	143.069	28.928	114.141	-31.790
1976	-0.795	2.735	-10.051	156.835	27.022	129.813	-29.949
1977	0.153	1.145	-10.832	154.109	25.266	128.844	-28.145
1978	0.721	-1.272	-12.485	140.622	23.648	116.976	-26.582
	<i>PGNP</i>	<i>RES</i>	<i>RM</i>	<i>RR</i>	<i>TL</i>	<i>TN</i>	
1967	0.001	-16.249	-58.067	0.079	0.797	0.989	
1968	0.000	-15.947	-9.558	-0.722	-6.813	-19.300	
1969	0.000	-15.346	26.477	-0.981	-13.446	-17.647	
1970	-0.000	-14.650	95.421	-0.942	-18.519	-24.289	
1971	-0.001	-13.900	156.598	-0.896	-23.984	-24.094	
1972	-0.002	-13.142	210.913	-1.140	-31.425	-25.718	
1973	-0.003	-12.358	262.223	-1.596	-42.371	-30.164	
1974	-0.004	-11.647	185.367	-1.807	-53.399	-3.750	
1975	-0.004	-10.973	93.778	-2.002	-65.582	-1.390	
1976	-0.005	-10.259	119.762	-2.698	-83.739	-36.379	
1977	-0.007	-9.597	118.012	-3.283	-104.660	-38.843	
1978	-0.007	-8.980	104.492	-3.787	-128.023	-42.856	

Table 5.6 Policy Change: 22% Decrease in *PIM*

	<i>CDMB</i>	<i>DCKB</i>	<i>DINVR</i>	<i>GNPR</i>	<i>IPRR</i>	<i>ITOTR</i>	<i>MR</i>
1967	0.364	12.637	-101.870	-434.250	-26.754	-128.625	301.246
1968	0.845	36.801	-109.957	-446.118	8.453	-101.503	330.972
1969	1.401	72.953	-104.922	-465.137	18.742	-86.179	352.793
1970	2.225	129.079	-128.548	-396.218	93.437	-35.109	346.250
1971	3.374	211.832	-97.211	-302.336	162.543	65.332	376.497
1972	4.729	325.945	-68.591	-251.848	201.484	132.891	411.860
1973	6.939	493.785	-16.885	-132.953	322.652	305.766	495.715
1974	10.192	741.007	36.517	75.586	426.199	462.715	502.957
1975	13.695	1059.523	89.249	138.438	408.695	497.945	527.563
1976	17.781	1465.906	134.214	290.250	623.184	757.398	685.050
1977	22.938	1988.566	198.655	399.937	680.215	878.867	736.664
1978	28.836	2637.886	268.773	518.250	753.691	1022.465	796.770
	<i>MRS</i>	<i>NCGMA</i>	<i>NDAMA</i>	<i>NFA</i>	<i>NFADMB</i>	<i>NFAMA</i>	<i>PCER</i>
1967	76.931	97.872	98.238	1042.176	-1.453	1043.628	-4.395
1968	84.522	105.417	106.257	2118.542	-2.778	2121.319	-13.605
1969	90.018	113.405	114.796	3251.681	-4.156	3255.837	-26.082
1970	59.060	176.497	178.698	4887.782	-6.452	4894.231	-14.265
1971	58.537	214.502	217.883	6826.993	-9.514	6836.506	8.628
1972	61.739	240.711	245.308	8999.962	-13.119	9013.081	30.465
1973	73.372	302.296	309.216	11621.389	-19.295	11640.684	57.125
1974	74.095	431.154	441.354	15970.732	-28.422	15999.156	115.660
1975	72.788	469.278	482.922	21249.269	-36.618	21285.885	168.671
1976	92.075	499.154	516.929	27165.487	-46.719	27212.204	217.657
1977	99.511	533.999	556.902	33553.043	-60.086	33613.130	257.871
1978	108.175	544.757	573.441	40949.095	-74.649	41023.746	294.473
	<i>PGNP</i>	<i>RES</i>	<i>RM</i>	<i>RR</i>	<i>TL</i>	<i>TN</i>	
1967	-0.004	0.513	1141.866	-3.157	-31.731	-293.086	
1968	-0.011	0.983	2227.574	-6.207	-80.372	-326.560	
1969	-0.018	1.491	3370.632	-9.509	-148.590	-372.008	
1970	-0.033	2.336	5072.929	-14.957	-256.383	-553.809	
1971	-0.050	3.486	7054.388	-22.303	-413.457	-705.532	
1972	-0.069	4.740	9258.389	-31.278	-627.324	-855.683	
1973	-0.100	7.082	11949.899	-46.090	-949.621	-1132.899	
1974	-0.147	10.404	16440.512	-68.102	-1427.871	-1796.305	
1975	-0.182	13.489	21768.809	-89.077	-2016.551	-2242.113	
1976	-0.229	17.251	27729.137	-115.156	-2774.180	-2702.242	
1977	-0.283	22.187	34170.035	-149.501	-3759.570	-3220.472	
1978	-0.341	27.561	41597.188	-188.003	-4976.816	-3916.231	

effects on other selected variables are shown from Tables 5.1 to 5.6.

The impact (first-year) multipliers for real *GNP* range between 0.009 to 1.485. A higher impact effect results from the change in government consumption expenditures compared to that for changes in real public investments since the increase in the latter variable results in a greater growth rate for imports. This increase in imports thus partly offsets the ₱ 300 million rise in *IPUR*. Whereas the impact multiplier for exports is similarly lower than that for government consumption expenditures, the exports multiplier builds up to a peak which even surpasses the expenditure multipliers over time. This implies that exports have a greater effect on real income in the long-run; a reason for this may be attributed to the highly open economy of the Philippines which makes exports constitute a bigger portion of real total income. The multiplier resulting from changes in Monetary Authority's claims on other banks (*COTB*) displays a minimal effect on *GNPR* and diminishes toward zero in an oscillatory pattern.

A sustained exogenous increase in government expenditures has a negative effect on prices for the first two (2) years and the inflationary impact of the policy is felt only in the fourth year. The inflationary effect, however, is still minimal at an average of 0.48 percent compared to an average increase of 1.1 percent in *GNPR*. There is a tradeoff, however, between the increase in productivity and the deterioration in the net foreign asset position of the Monetary System.

According to the model, the sustained

increase in public investments results in greater inflationary effects. This is because the increase in *IPUR* necessitates less financing from the Monetary Authorities compared to the financing needed in expanding *GCER*. Consequently, in the case when *IPUR* is expanded, reserve money declines less, which in turn causes prices to increase at a greater pace. Within the model's context, the supply of liquidity becomes less than the demand for liquidity, forcing prices in the upward direction.

A sustained increase in exports increases liquidity only in the first few years, but subsequently is siphoned off due to bigger increases in reserve money. In accordance with what theoretical analysis would lead us to expect, the net foreign asset position of the Monetary System is improved.

The direct effect of tighter money due to the increase in Central Bank's discount rate, is the decrease in loans of deposit money banks from Central Bank and consequently, deposit money banks' supply of loans to the private sector. General economic activity becomes slack and real income and its components decline.

Finally, the fall in import prices induces an expansion in the value of real imports which in turn causes a decrease in real income. *Ceteris paribus*, a higher import value is expected to cause a drainage in foreign exchange and thus a deterioration in the net foreign assets of the Monetary System. However, this does not occur since within the model's context, the decrease in import prices pulls down the nominal import value, which instead considerably improves the Monetary System's net foreign asset position.

In keeping with import prices, over-all prices in the form of the *GNP* deflator, similarly move in the downward direction.

VII Conclusion

The various exercises on simulation applied to the model suggest that the system provides

a good starting point for what could be a very useful tool for macroeconomic policy analysis. Respecifications, however, must still be made on certain equations for monetary sector variables to improve on the unfavorable ex-post simulation results obtained, and thus to improve the over-all workability of the model.

Data Appendix

PHILIPPINES DATA

YEAR	GCER	TNR	GNP	GNPR	PCER	X
1947	*	*	5699.000	12072.000	9133.000	1185.000
1948	1355.000	929.700	6197.000	14023.000	10421.000	1273.000
1949	1525.000	1004.000	6517.000	14907.000	12099.000	897.000
1950	1613.000	1104.000	6948.000	16341.000	12631.000	969.000
1951	1645.000	1724.000	7708.000	17989.000	13616.000	1174.000
1952	1805.000	1888.000	8111.000	19337.000	14828.000	1063.000
1953	1864.000	1886.000	8510.000	20691.000	16607.000	1234.000
1954	1955.000	2064.000	8828.000	22278.000	18118.000	1203.000
1955	2037.000	2334.000	9404.000	23709.000	19423.000	1222.000
1956	2091.000	2607.000	10287.000	25577.000	20200.000	1165.000
1957	2159.000	2665.000	11232.000	26928.000	21008.000	1116.000
1958	2244.000	2546.000	11905.000	27997.000	21848.000	1200.000
1959	2296.000	2723.000	12943.000	29746.000	22722.000	1275.000
1960	2495.000	2989.000	13833.000	30151.000	23631.000	1489.000
1961	2642.000	3207.000	15161.000	32242.000	24789.000	1708.000
1962	2714.000	3494.000	17030.000	34019.000	26202.000	2572.000
1963	2922.000	3778.000	19793.000	36383.000	27774.000	3284.000
1964	3041.000	4010.000	21383.000	37627.000	28885.000	3468.000
1965	3168.000	3839.000	23382.000	39520.000	30300.000	4046.000
1966	3169.000	4000.000	25745.000	41240.000	31845.000	4716.000
1967	3289.000	4451.000	28734.000	43224.000	33342.000	4903.000
1968	3631.000	4808.000	31791.000	45540.000	35033.000	4713.000
1969	3972.000	4924.000	35012.000	47967.000	36435.000	4578.000
1970	4228.000	5605.000	41751.000	50035.000	37088.000	8095.000
1971	4554.000	6236.000	49599.000	52921.000	38499.000	9260.000
1972	5260.000	6322.000	55526.000	55526.000	39922.000	9877.000
1973	5835.000	8977.000	71616.000	60881.000	42317.000	15932.000
1974	6659.000	9344.000	99631.000	64508.000	44385.000	22266.000
1975	7031.000	9712.000	114265.000	68530.000	46160.000	21272.000
1976	7570.000	9086.000	132712.000	72718.000	47868.000	23248.000
1977	8009.000	9627.000	152693.000	77279.000	49830.000	29200.000
1978	8528.000	11230.000	171940.000	81961.000	52321.000	32272.000

YEAR	XR	M	MR	IPRR	DINVR	TN
1947	3289.000	1412.000	6857.000	2597.000	603.000	312.000
1948	4746.000	1299.000	6734.000	2938.000	500.000	407.000
1949	3555.000	1325.000	8673.000	2081.000	279.000	432.000
1950	3470.000	870.000	4354.000	1775.000	368.000	467.000

Data Appendix (Continued)

YEAR	XR	M	MR	IPRR	DINVR	TN
1951	3998.000	1135.000	5246.000	1987.000	263.000	735.000
1952	4646.000	998.000	4632.000	1874.000	280.000	789.000
1953	4562.000	1030.000	5077.000	2424.000	422.000	767.000
1954	4831.000	1098.000	5691.000	2360.000	701.000	809.000
1955	5319.000	1249.000	6494.000	2432.000	763.000	913.000
1956	4601.000	1208.000	6007.000	2910.000	535.000	1042.000
1957	4767.000	1443.000	7052.000	3613.000	646.000	1103.000
1958	4929.000	1300.000	6206.000	3455.000	789.000	1074.000
1959	4771.000	1213.000	5573.000	4106.000	891.000	1173.000
1960	5110.000	1460.000	6253.000	3498.000	805.000	1358.000
1961	5279.000	1942.000	6366.000	4097.000	1019.000	1502.000
1962	6118.000	2980.000	6417.000	3808.000	1218.000	1747.000
1963	7286.000	3053.000	6115.000	4605.000	1398.000	2053.000
1964	7723.000	3600.000	7375.000	5844.000	1229.000	2277.000
1965	8773.000	4040.000	7818.000	6025.000	1314.000	2267.000
1966	9308.000	4303.000	8193.000	5784.000	1417.000	2491.000
1967	9615.000	5438.000	10069.000	6802.000	1304.000	2930.000
1968	8522.000	5754.000	10829.000	6780.000	2032.000	3319.000
1969	8170.000	5807.000	11027.000	6325.000	2326.000	3563.000
1970	8744.000	8236.000	9990.000	6647.000	2916.000	4664.000
1971	8997.000	9648.000	10015.000	6914.000	2536.000	5839.000
1972	9877.000	10334.000	10334.000	6270.000	2742.000	6322.000
1973	11312.000	13392.000	10800.000	6175.000	3455.000	10576.000
1974	9980.000	25400.000	12883.000	7093.000	4269.000	14515.000
1975	9951.000	29057.000	13505.000	9430.000	3947.000	16282.000
1976	11931.000	31841.000	13679.000	9942.000	3915.000	16679.000
1977	14036.000	34675.000	14409.000	9729.000	3720.000	19169.000
1978	14265.000	41463.000	16308.000	10776.000	4271.000	23723.000

YEAR	ER	TL	DCKB	DUM1	DISC	NFADMB
1947	2.000	0.0	*	*	0.0	*
1948	2.000	0.0	*	*	0.0	*
1949	2.000	0.0	*	*	1.500	*
1950	2.000	0.0	*	*	3.000	*
1951	2.000	0.0	*	*	3.000	*
1952	2.000	0.0	*	*	2.000	*
1953	2.000	0.0	*	*	2.000	*
1954	2.000	0.0	*	*	1.500	*
1955	2.000	1758.000	*	*	1.500	*
1956	2.000	2001.000	*	*	1.500	*
1957	2.000	2182.000	*	*	4.500	*
1958	2.000	2430.000	*	*	4.500	*
1959	2.000	2649.000	*	*	6.500	*
1960	2.721	2828.000	*	*	5.000	*
1961	2.755	3470.000	*	*	3.000	*
1962	3.799	3990.000	*	*	6.000	*
1963	3.900	4813.000	3551.300	*	6.000	87.900
1964	3.899	4931.000	4200.699	*	6.000	-119.500
1965	3.899	5183.000	4352.598	*	6.000	41.200
1966	3.899	6098.000	4890.496	*	4.750	268.600
1967	3.916	7124.000	5832.000	1.000	6.000	314.500
1968	3.916	7521.000	6414.297	1.000	7.500	258.100
1969	3.919	8619.000	7443.199	1.000	8.000	192.400
1970	5.863	9388.000	8705.297	1.000	10.000	-242.900
1971	6.432	10494.000	9879.699	1.000	10.000	-845.000

Data Appendix (Continued)

YEAR	ER	TL	DCKB	DUM1	DISC	NFADMB
1972	6.671	11871.000	11954.199	1.000	10.000	-1809.700
1973	6.756	18063.000	16128.898	0.0	10.000	-1084.100
1974	6.788	24242.000	25058.098	0.0	10.000	-2381.000
1975	7.248	28886.000	28174.398	0.0	6.000	-2025.400
1976	7.440	35897.000	32633.098	0.0	6.000	-3846.100
1977	7.403	43931.000	37959.496	0.0	6.000	-5053.797
1978	7.366	51837.000	48159.000	0.0	4.000	-7806.000

YEAR	NFAMA	CDMB	RM	COTB	NUAMA	NCGMA
1947	*	*	*	*	*	*
1948	*	*	*	*	*	*
1949	*	*	*	*	*	*
1950	*	*	*	*	*	*
1951	*	*	*	*	*	*
1952	*	*	*	*	*	*
1953	*	*	*	*	*	*
1954	*	*	*	*	*	*
1955	*	*	*	*	*	*
1956	*	*	*	*	*	*
1957	*	*	*	*	*	*
1958	*	*	*	*	*	*
1959	*	*	*	*	*	*
1960	*	*	*	*	*	*
1961	*	*	*	*	*	*
1962	*	*	*	*	*	*
1963	220.200	217.500	1688.100	336.100	-18.000	1158.300
1964	266.200	362.400	1559.300	400.200	-278.700	1025.900
1965	306.400	458.700	1733.200	386.900	-353.800	1152.700
1966	146.700	566.400	1872.100	514.200	-241.600	1121.300
1967	-220.100	1074.700	2423.300	704.400	-121.400	1279.700
1968	-389.200	1256.000	2590.600	683.900	-191.400	1516.800
1969	-809.000	1323.100	2952.900	784.100	-156.300	2085.400
1970	-382.000	1018.000	3220.000	836.000	-45.000	2133.000
1971	365.000	875.000	3546.000	988.000	18.000	2014.000
1972	792.000	1022.000	4423.000	1169.000	842.000	1897.000
1973	4177.000	650.000	4993.000	959.000	1532.000	526.000
1974	6258.000	2870.000	6147.000	1037.000	530.000	-216.000
1975	1386.000	6213.000	7004.000	1584.000	2198.000	1971.000
1976	1733.000	4279.000	7948.000	2270.000	3410.000	3287.000
1977	3960.000	2904.000	9814.000	2659.000	5070.000	3637.000
1978	5716.000	3645.000	12093.000	3267.000	5945.000	3838.000

YEAR	RR	PGNP	DCTMS	TLR	NDAMA	TM
1947	*	0.472	*	0.0	*	1.000
1948	*	0.442	*	0.0	*	2.000
1949	*	0.437	*	0.0	*	3.000
1950	*	0.425	*	0.0	*	4.000
1951	*	0.428	*	0.0	*	5.000
1952	*	0.419	*	0.0	*	6.000
1953	*	0.411	*	0.0	*	7.000
1954	*	0.396	*	0.0	*	8.000
1955	*	0.397	*	4432.199	*	9.000
1956	*	0.402	*	4975.168	*	10.000

Data Appendix (Continued)

YEAR	RR	PGNP	DCTMS	TLR	NDAMA	TM
1957	*	0.417	*	5231.203	*	11.000
1958	*	0.425	*	5714.633	*	12.000
1959	*	0.435	*	6088.012	*	13.000
1960	126.000	0.459	*	6164.027	*	14.000
1961	142.000	0.470	*	7379.441	*	15.000
1962	228.000	0.501	*	7970.391	*	16.000
1963	290.000	0.544	4161.496	8847.137	1467.900	17.000
1964	178.000	0.568	4912.496	8676.926	1293.100	18.000
1965	120.000	0.592	5454.395	8760.250	1426.800	19.000
1966	185.000	0.624	6025.496	9768.168	1725.400	20.000
1967	316.000	0.665	7484.797	10716.492	2643.400	21.000
1968	588.000	0.698	8287.094	10773.687	2979.800	22.000
1969	673.000	0.730	9939.496	11808.164	3761.900	23.000
1970	520.000	0.834	11183.496	11250.711	3602.000	24.000
1971	591.000	0.937	12262.598	11196.855	3181.000	25.000
1972	649.000	1.000	14145.199	11871.000	3631.000	26.000
1973	896.000	1.176	18747.797	15355.426	816.000	27.000
1974	1459.000	1.544	28137.395	15695.949	-111.000	28.000
1975	1641.000	1.667	34006.598	17324.270	5618.000	29.000
1976	1680.000	1.825	40216.098	19669.352	6215.000	30.000
1977	2168.000	1.976	47278.293	22233.789	5854.000	31.000
1978	1605.000	2.098	58518.598	24709.852	6377.000	32.000

YEAR	ITOTR	IPUR	MRS	PIM	NOA	NFA
1947	3331.000	131.000	3428.500	0.206	*	*
1948	3773.000	335.000	3367.000	0.193	*	*
1949	2903.000	543.000	4336.500	0.153	*	*
1950	2632.000	489.000	2177.000	0.200	*	*
1951	2607.000	357.000	2623.000	0.216	*	*
1952	2528.000	374.000	2316.000	0.215	*	*
1953	3248.000	402.000	2538.500	0.203	*	*
1954	3572.000	511.000	2845.500	0.193	*	*
1955	3838.000	643.000	3247.000	0.192	*	*
1956	4239.000	794.000	3003.500	0.201	*	*
1957	5088.000	829.000	3526.000	0.205	*	*
1958	5097.000	853.000	3103.000	0.209	*	*
1959	5886.000	889.000	2786.500	0.218	*	*
1960	5173.000	870.000	2298.052	0.233	*	*
1961	6001.000	885.000	2310.708	0.305	*	*
1962	5931.000	905.000	1689.262	0.464	*	*
1963	7037.000	1034.000	1568.070	0.499	226.000	308.100
1964	7914.000	841.000	1891.269	0.488	216.700	146.700
1965	8336.000	997.000	2004.873	0.517	217.700	347.600
1966	8405.000	1204.000	2101.039	0.525	234.900	415.300
1967	9706.000	1600.000	2571.378	0.540	294.000	94.400
1968	10691.000	1879.000	2765.463	0.531	285.500	-131.100
1969	11231.000	2580.000	2813.657	0.527	274.400	-616.600
1970	10835.000	1272.000	1703.993	0.824	340.000	-624.900
1971	11226.000	1776.000	1557.131	0.963	714.000	-480.000
1972	11573.000	2561.000	1549.093	1.000	1299.000	-1017.700
1973	12540.000	2910.000	1598.532	1.240	2851.000	3092.900
1974	15651.000	4289.000	1897.908	1.972	4332.000	3877.000
1975	18984.000	5607.000	1863.298	2.152	6348.000	-639.400
1976	20225.000	6368.000	1838.526	2.328	7031.000	-2113.100
1977	20363.000	6914.000	1946.426	2.406	8416.000	-1093.797
1978	23065.000	8018.000	2214.076	2.542	10318.000	-2090.000

Data Appendix (Continued)

YEAR	NFI	PEX	DK	DUM3	RDS	RES
1947	*	0.360	*	*	*	*
1948	462.000	0.268	*	*	*	*
1949	3498.000	0.252	*	*	*	*
1950	349.000	0.279	*	*	*	*
1951	1369.000	0.294	*	*	*	*
1952	162.000	0.229	*	*	*	*
1953	-513.000	0.270	*	*	*	*
1954	-507.000	0.249	*	*	*	*
1955	-414.000	0.230	*	*	*	*
1956	453.000	0.253	*	*	*	*
1957	958.000	0.234	*	*	*	*
1958	85.000	0.243	*	*	*	*
1959	-356.000	0.267	*	*	*	*
1960	-5.000	0.291	*	*	*	*
1961	-103.000	0.324	*	*	*	*
1962	-529.000	0.420	*	*	*	*
1963	-2521.000	0.451	*	*	*	324.700
1964	-2561.000	0.449	-29.400	*	*	234.600
1965	-3239.000	0.461	194.900	*	*	250.000
1966	-3294.000	0.507	-345.300	*	*	328.700
1967	-2659.000	0.510	214.100	0.0	6.625	667.600
1968	-1508.000	0.553	815.500	0.0	6.469	813.100
1969	-814.000	0.560	743.500	0.0	6.314	833.800
1970	-870.000	0.926	132.700	0.0	12.430	810.400
1971	-340.000	1.029	532.908	0.0	12.470	896.400
1972	-772.000	1.000	-80.700	0.0	7.579	988.500
1973	-323.000	1.408	1570.598	1.000	14.320	1540.200
1974	716.000	2.231	3918.096	1.000	22.069	1836.100
1975	-91.000	2.138	3268.599	0.0	18.568	2255.200
1976	-1197.000	1.949	7119.301	0.0	15.030	2296.300
1977	-550.000	2.080	6494.305	0.0	12.741	3086.000
1978	90.000	2.262	8194.797	0.0	12.619	3958.100

YEAR	PGCE	USPR	DUMNCGMA	TIME
1947	0.364	*	*	*
1948	0.344	*	*	*
1949	0.315	*	*	*
1950	0.321	*	*	*
1951	0.342	*	*	*
1952	0.341	*	*	*
1953	0.350	*	*	*
1954	0.345	*	*	*
1955	0.357	*	*	*
1956	0.380	*	*	*
1957	0.396	*	*	*
1958	0.409	*	*	*
1959	0.431	*	*	*
1960	0.438	*	*	*
1961	0.477	*	*	*
1962	0.523	*	*	*
1963	0.592	*	*	*
1964	0.629	*	*	*
1965	0.669	*	*	*
1966	0.723	*	*	*
1967	0.778	6.000	0.0	1.000
1968	0.781	6.750	0.0	2.000
1969	0.786	8.500	0.0	3.000

Data Appendix (Continued)

YEAR	PGCE	USPR	DUMNCGMA	TIME
1970	0.831	6.750	0.0	4.000
1971	0.938	5.250	0.0	5.000
1972	1.000	6.000	0.0	6.000
1973	1.068	10.000	0.0	7.000
1974	1.351	10.500	1.000	8.000
1975	1.557	7.250	0.0	9.000
1976	1.856	6.250	0.0	10.000
1977	1.951	7.750	0.0	11.000
1978	2.067	11.750	0.0	12.000

In updating the statistical data, corrections have been discovered in the data sources. Since, however, the present work is based on old data, the data appendix was left unchanged. The updated data contain the following corrections:

YEAR	GCER	GNP	GNPR	PCER	X
1947	1,087.0	(74) 99,948.0	(74) 64,739.0	—	—
1977	7,456.0	154,280.0	77,728.0	51,416.0	29,306.0
1978	7,788.0	178,067.0	82,547.0	54,098.0	31,557.0

YEAR	XR	M	MR	IPRR	DINVR	TN
1974	—	—	—	(69) 6,375.0 7,094.0	(53) 424.0	—
1977	14,311.0	—	14,235.0	9,334.0	—	19,043.0
1978	14,257.0	41,321.0	16,116.0	10,283.0	3,951.0	23,947.0

YEAR	ER	TL	CDMB	RM	COTB
1962	3.808	—	(63) 184.0	—	—
1964	3.900	—	362.0	—	—
1965	3.900	—	457.0	—	—
1966	3.895	6,099.0	566.0	—	(68) 684.0
1967	3.915	—	1,075.0	2,423.0	(72) 1,168.0
1970	6.025	—	—	(68) 2,591.0	(73) 958.0
1972	6.675	(76) 35,898.0	1,023.0	(69) 2,953.0	(76) 2,271.0

YEAR	ITOTR	IPUR	PIM	PEX
1977	21,169.0	8,115.0	2.436	2.048
1978	23,243.0	9,009.0	2.564	2.213