

**THE HADZA AND THE IRAQW IN NORTHERN TANZANIA:
DERMATOGRAPHICAL, ANTHROPOMETRICAL, ODONTOMETRICAL
AND OSTEOLOGICAL APPROACHES**

Jiro IKEDA* and Sugio HAYAMA**
Department of Physical Anthropology, Kyoto University*
Department of Anatomy, Kansai Medical University**

ABSTRACT

The dermatoglyphics, physical measurements, tooth size and dental arch measurements of 4 populations of Mangola are analyzed and the racial affinities of earlier inhabitants are discussed based on the human remains excavated from Gishimangeda cave and Sechikuencho cairns. The Iraqw, Datoga and the Hadza were investigated as representing the Hamitic, Nilotic and the Khoisan speaking people. The Iraqw and Datoga bear a close resemblance in physical features to the other members of the Hamitic or Caucasians as well as the Bantu speakers, while the Datoga are closer to the Bantu than the Iraqw do. On the other hand, the Hadza are quite different from the Iraqw and Datoga, and approach mostly to the North Bushmen and fairly resemble the neighbouring Bantu tribes. The Gishimangeda and Sechikuencho skeletal series can be dated to probably the 13th or 14th century and 18th or 19th century respectively. They are in most essentials hybrid population between the Mediterraneans and the Negroes, but are closer to the latter. The living Mangola peoples with such mixed physical traits are the Iraqw or Datoga among 4 populations examined by us. The occupant of Mangola during several centuries ago, therefore, can be suggested as the Nilotic or the Hamitic peoples, probably the former. The Hadza has not been attached linguistically and physically to any definite people. There are no trace of early Khoisanoid in this region.

INTRODUCTION

There are many tribes in Mangola village on the northern shore of Lake Eyasi, northern Tanzania. They are, in fact, divided into 31 tribes of 5 different linguistic families or sub-families: 22 of Bantu, 3 of Hamitic, 3 of Nilotic, 2 of Khoisan and 1 of Somali (Wazaki, 1970). Tribal constitution in this village is extremely significant, for various tribes of cultural and hereditary diversity have coexisted in this limited area, and the Hadza and Iraqw, whose racial relationships are still obscure, both seem to be isolated from their main stock—the Khoisan in South Africa and the Hamitic in Northeast Africa respectively.

The historical process of settlement of the tribes in Mangola was as follows. The inhabitants of this village in the early part of the 1900's were the Hadza and Masai, and settlement of another tribes began around 1930 by the Bantu speaking people who were followed by the Datoga, and subsequently by the Iraqw (Wazaki, 1970). No information about any tribe before the beginning of the century is available.

The main subject of this paper is to elucidate the racial affinities of the Mangola peoples, particularly of the Hadza and Iraqw, deduced from

dermatographical, anthropometrical and odontometrical aspects, of which the major portion has already reported by one of the authors (Ikeda, 1977), and to obtain some informations on earlier inhabitants in this area from osteological studies of human skeletal remains excavated at the prehistoric sites.

The material on which this paper is based was obtained during the period from July to December, 1967, by the Physical Anthropological and Palaeontological party (the authors and Dr. T. Kamei) of the Kyoto University Africa Scientific Expedition.

TRIBES OF MANGOLA VILLAGE

Since the Hadza, Iraqw, and the Datoga predominate among the respective linguistic group, these tribes were investigated as representing the Khoisan, Hamitic and the Nilotic speaking people. Somali was excluded from the object of this study because of its small sample size.

The Hadza: They are divided into two regional groups, the eastern and the western Hadza. The total population was estimated as 500-600 and the population of Mangola Hadza, one of subgroup among the eastern group, as about 80. They still lead an independent life of hunting and gathering and speak a language similar to Khoisan in click consonant but different from it in vocabulary (Tomita, 1966). This tribe and the Sandawe, an agricultural and pastoral people some 125 miles southeast from Mangola, are both considered as offshoots from the same main population of the Khoisan linguistic stock in South Africa.

According to Trevor (1947), the Sandawe are morphologically similar to the Hottentot and also the Nyaturu, one of the neighbouring Bantu tribes. From previous anthropometrical and dermatographical investigation (Ikeda, 1977), we tentatively considered the Hadza and the Khoisan speaking people to be related. On the other hand, Barnicot et al. (1972b), who examined the Hadza dermatoglyphics, concluded that there was no convincing evidence of resemblance to the Bushmen but that some features were compatible with the Hamitic speaking people in Northeast Africa, supporting the suggestion by Tucker (1967) that the Hadza language is related to the Cushitic language, a branch of the Hamitic stock.

In 1966-68, the late N. Barnicot and his colleagues carried out a biomedical survey of the eastern Hadza. A number of papers have already been published on various aspects of this population: ecology (Woodburn, 1968a,b, 1972), parasitology (Barnicot et al., 1970), blood pressures and serum cholesterol (Barnicot et al., 1972a), dermatoglyphics (Barnicot et al., 1972b), colour-blindness and sensitivity to PTC (Barnicot & Woodburn, 1975), inbreeding coefficient (Stevens et al., 1977) and anthropometry (Hiernaux & Hartono, 1980).

The Iraqw: The Iraqw language has not been attached conclusively to any definite language stock, but is regarded as of Cushites, followed Murdock (1959). Barnicot et al. (1972b) wrote that Tucker found no specific linguistic connection between this tribe and the Hadza. Most of the Cushitic speaking peoples inhabit various places in Northeast Africa, and only six tribes, including the Iraqw, are known as the Southern Cushites, who live in, or immediately adjacent to, the Rift Valley in northern Tanzania. Murdock (1959) suggested a long period of isolation and linguistic differentiation of the southern group from the main stock in Northeast Africa. The Cushitic speaking people are presumed to be classified as an Ethiopian sub-race, that is, a Mediterranean mixed with the Negro.

The Iraqw occupy an area extending north-south from the center of

the Mbulu District, Arusha Province, Tanzania. They number about 130,000 and practice agriculture and herding (Yoneyama, 1969). Allison et al. (1954) reported on their blood group frequencies.

The Datoga: The Datoga are widely spread over 4 provinces of northern Tanzania, but the majority is concentrated in the Mbulu District. Their total population is estimated to be 28,000 (Tomikawa, 1970). They would seem to bear marked physical resemblances to the Nandi and Masai in Kenya and Tanzania, all of whom are primarily pastoral peoples of the Nilotic, although no research has been carried out on the physical traits of this tribe.

The Nyamwezi Cluster: The Bantu speaking people were examined regardless of tribe in this study. About 90 per cent of the examinees, however, were members of the Nyamwezi Cluster, in which the most dominant tribe is the Isanzu, followed by the Iramba, Sukuma, Nyaturu and the Nyamwezi. Therefore, the Bantu examinees will be here termed the Nyamwezi Cluster. Morphological traits of the Nyaturu were presented by Trevor (1947), though Hiernaux (1968) showed the results of the extensive work on the physical features of the living populations of sub-Saharan Africa including the Nyamwezi and Nyaturu. Genetic polymorphisms in the Sukuma were reported by Roberts & Papiha (1978) and Roberts et al. (1979).

EXCAVATION AT GISHIMANGEDA CAVE AND SECHIKUENCHO CAIRNS

1. Gishimangeda Cave

Gishimangeda situated in the northeastern part of Mangola village some 2.5 miles from the shore of Lake Eyasi (Fig.1). The cave at hillside

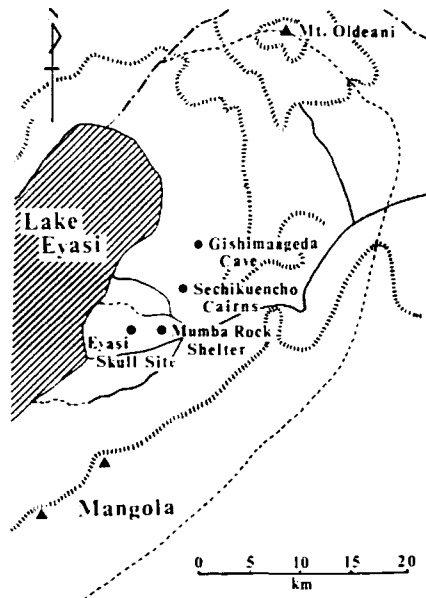

Fig. 1. Prehistoric sites in Mangola village.

of an isolated hill, composed of nepheline basalt, is 6 meters wide at the opening toward south, and 2 meters deep.

The excavation at this site was a trench, 6x2 meters wide at the surface, and placed inside of the cave. It revealed three main layers: 1. Surface. Dark brown, wind-born sand, about 60cm of depth, containing some fragments of human and animal bones, stone saddle querns, a bone awl, and pottery sherds. 2. Brown, wind-born sand, more clayly and calcareous than in the first layer, about 120cm of depth, containing seven human burials. 3. Brown sand, cemented by calcareous substance, about 15cm of depth. The lower part of the third layer contains a number of pebbles. A bone awl made of bovid femur in the upper part and a grindstone in the lower part are found. From the top to the bottom, particularly in the second layer, there are many debris of quartzite and obsidian. A radiocarbon date for this site is 610 ± 260 B.P., obtained on a burned animal bone from the upper part of the third layer.

Among seven burials in the second layer, including six adults and one infant, five were buried lying on their left sides, one on its right side and one on the back, all in a flexed position (Fig.2). There seems to be no discernible overall tendency in direction of body axis.

2. Sechikuencho Cairns

Sechikuencho is about 3 miles southwest from Gishimangeda, and has been dotted with some houses of the Datoga (Fig.1). There are several cairns, amongst them four cairns were unearthed by us.

Cairns are 3.5 to 4 meters in diameter and about 20cm in height on the ground surface, beneath which is found a shallow grave with depth of 50 to 80cm. In the center of grave, there is a shaft pit, about 90 to 130cm in depth, which contains a burial in a crouched position, facing east (Fig.3). Many fragments of animal bones, eight stone saddle querns, a pipe-shaped clay product, and a fragment of pottery were recovered among stones forming cairn. No material available for dating was obtained.

Bräuer (1976) examined the conditions of the skeletons, graves and artifacts from 14 cairns situated on the northern shore of Lake Eyasi, which were excavated in 1938 by Prof. L. Kohl-Larsen, and assumed that these cairn might not be older than 500 years. Then he supposed,

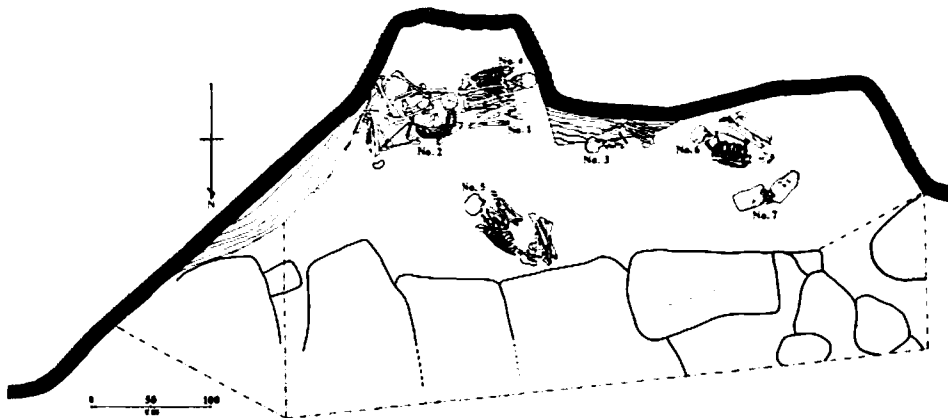

Fig. 2. Human burials in the 2nd layer at Gishimangeda Cave.

SECHIKUENCHO TOMB NO

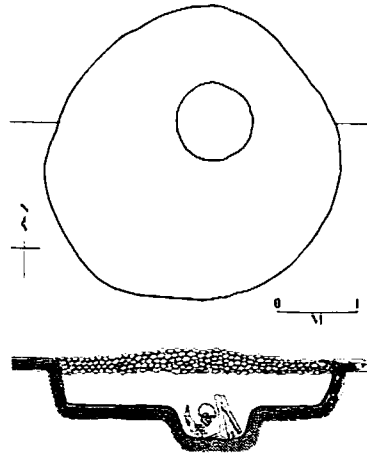

Fig. 3. A human burial in the cairn No. 2 at Sechikuencho.

according to the radiocarbon date of 1810 ± 50 A.D. on charcoal from the grave 1, that the individuals were buried here in the 18th or 19th century. Bräuer termed this skeletal series as "Masai grave" skeletons. There is a remarkable consistence in the size, structure of the graves, burial posture, and artifacts between the cairns excavated by us and "Masai grave". During our excavation, moreover, we got informations that Kohl-Larsen dug some cairns here formerly and we saw actually traces of excavated graves. Putting these facts together, it is possible that "Masai grave" and the cairns unearthed by us were situated at the same cemetery in Sechikuencho. We deduce provisionally the date of Sechikuencho cairns also to be 18th or 19th century, followed Bräuer.

DERMATOGRAPHY

Our samples of the Hadza are small and are probably contained within those of the eastern Hadza examined by Barnicot et al. (1972b). For the Hadza, therefore, frequencies of digital and palmar patterns obtained by Barnicot were used, while for the Iraqw, Datoga and Nyamwezi Cluster we used the frequencies examined by ourselves.

1. Digital Pattern

According to Barnicot, predominance of whorls is a characteristic of the Hadza, and its frequency, 35.7% for males is near to the upper limit of the range of variation from 15 to 40% for the various populations in Africa. Digital whorl frequencies are relatively high for populations in an area from Senegal round the coastal region of North Africa to the Near East, and also for the Bushmen, whose range of variation is 30.2-39.7%. Among the Pygmy groups, some populations have markedly low frequencies, but others have above 35%.

The Hadza and Iraqw approach to the Hamitic and differ from the Datoga and Nyamwezi Cluster in having high whorl frequencies and Cummins index, while the range of variation for the Bantu, Khoisan and Pygmy groups are notably wide and some populations amongst them show

Table 1. Digital pattern frequencies of 4 populations in Mangola

	n	Digital pattern				Cummins index
		U	R	W	A	
Hadza(Barnicot)	217	60.7	1.8	35.7	2.3	13.4
Iraqw	92	52.9	2.8	37.6	6.6	13.1
Datoga	91	62.1	1.5	32.1	4.3	12.8
Nyamwezi Cluster	69	63.9	3.0	27.1	6.1	12.1

frequencies similar to those of the Hamitic (Table 1, Fig.4).

2. Palmar Pattern

Pons u. Fusté (1962) showed a sharp contrast between the European and the Negro in frequencies of type 7, 9 and 11, the three kinds of line-D ending pattern described by Cummins-Midlo, and in its mean score. Barnicot based his argument on the result that the mean score 9.8 for the Hadza male fell within the range of variation for the European (9.3-10.0) and was out of that for the Negro (7.8-8.7), but he did not make similar comparisons for the Khoisan group.

Among 4 populations in Mangola, the Hadza have a remarkably low frequency of type 7 and high frequency of type 11 and the ratio of the latter to the former is above 4.0 (Table 2). On the other hand, the Datoga and Nyamwezi Cluster have a high frequency of type 7 than of type 11, its ratio being naturally less than 1.0, while for the Iraqw type 9 is the highest, followed by type 11, and the ratio of type 11 to type 7 is

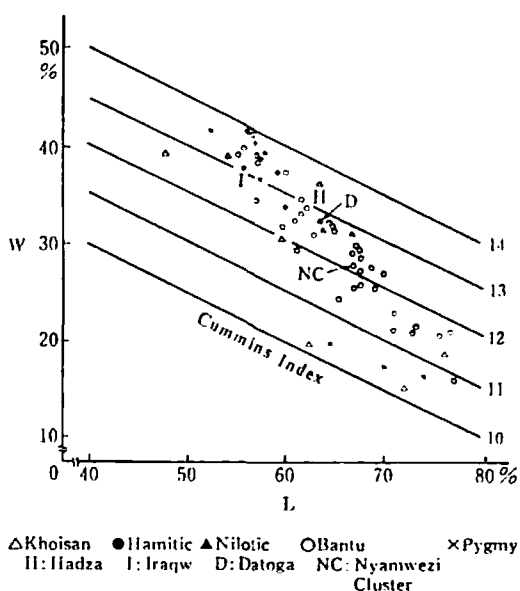

Fig. 4. Frequencies of whorls and loops, and Cummins index.

Table 2. Frequencies of three types of line-D ending pattern for Mangola populations

	n	Types of line-D ending				Mean score
		7	9	11	11/7	
Hadza(Barnicot)	220	11.4	38.6	50.0	4.39	9.8
Iraqw	90	27.1	42.0	30.9	1.14	9.1
Datoga	90	40.2	26.8	33.0	0.82	8.9
Nyamwezi Cluster	64	41.7	26.8	31.5	0.76	8.9

above 1.0. Mean score for the Hadza is different from those for the remaining three populations, which fall within a gap between the lower limit of the European and the upper limit of the Negro.

A comparison of frequencies of three types of line-D ending pattern for Mangola populations with those for the Bantu and Khoisan groups and with the ranges of variation for the European and Negro (Fig.5), reveals that the Hadza and Khoisan group, of which type 11 exceeds type 7, are contained in the European variation range but the Bantu group, including the Nyamwezi Cluster, are in or close to the Negro variation range. The Iraqw and Datoga occupy an intermediate position between the European and the Negro, but the former is close to the European and the latter to the Negro.

Considering the results of examination of dermatoglyphic pattern, we find that the affinities of the Hadza to the Khoisan can not be completely rejected, even though the possibility that the Hadza are comparable with the Hamite in Northeast Africa is also acceptable. Similarly, the Iraqw have not been conclusively attached to a definite racial group.

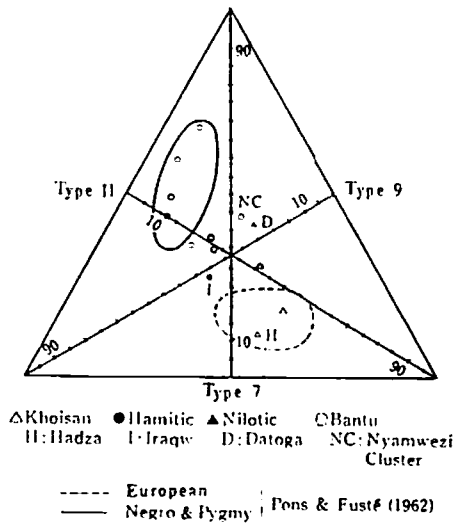

Fig. 5. Frequencies of type 7, 9, and 11, the three kinds of line-D ending pattern described by Cummins-Midlo.

ANTHROPOMETRY

1. Comparison among 4 Populations in Mangola

Hiernaux & Hartono (1980) presented the means and standard deviations of all measurements taken by Barnicot on adult Hadza and discussed the physical and nutrition states of this population, such as sex dimorphism of subcutaneous fat and of stature, weight/height relationship. Comparing the means of the main measurements for 126 males given by them with those for 27 males obtained by us, there are no significant differences. Particularly, the means of stature, head length and breadth for both data coincide with one another.

Twenty measurements on 27 males of the Hadza, 51 of the Iraqw, 93 of the Datoga and 48 of the Nyamwezi Cluster were compared with one another by multivariate analysis.

Canonical Functions 1 and 2 account for 78.4% and 14.6% of inter-group variation respectively (Fig.6). Discrimination is attributed mainly to Function 1, which seems clearly to oppose the Hadza at one end of the scale to the Datoga at the other and the other two populations tend to fall closer to the latter. Function 2 appears to be concerned only with separation of the Nyamwezi Cluster from the rest. Combination of both functions separates the Hadza almost completely from the Datoga, and fairly from the Iraqw and Nyamwezi Cluster, while the Datoga and Iraqw coincide with one another and the Nyamwezi Cluster overlap both populations fairly. Discriminant loadings are relatively high for a longitudinal component of body, a breadth component of body and a size component of head, with the positive sign in Function 1, and a component concerned with stoutness of body, a breadth component of head and face, with the negative sign in Function 2.

As D-squares supported the results mentioned above (Table 3), it may be concluded that the Hadza are significantly different from the other three populations, particularly from the Datoga, and the population closest to the latter is the Iraqw, to whom in turn the closest is the Nyamwezi Cluster.

2. Analysis of Differences among 4 Populations of Mangola

To settle the question of whether metrical differences can be attributed either to hereditary or environmental factor, comparisons of

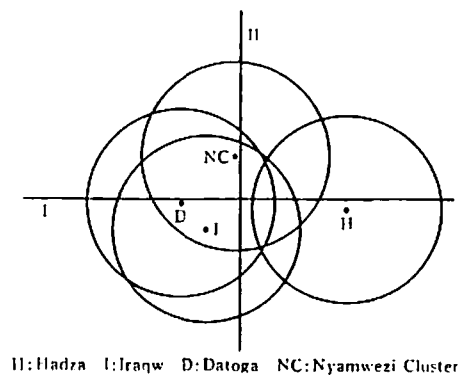

Fig. 6. The centroids and distributions of 4 populations of Mangola on the first two canonical functions computed for 20 anthropometrical variables.

Table 3. Mahalanobis's D^2 on 20 measurements

	Hadza	Iraqw	Datoga
Iraqw	11.60		
Datoga	15.59	2.15	
Nyamwezi Cluster	8.48	3.41	3.70

inter-group differences in more ecosensitive measurements with those in more heritable measurements were made on two sub-populations of the Hutu with very different environments by Hiernaux (1963) and on culturally homogeneous - genetically heterogeneous Melanesian populations by McHenry & Giles (1971). Since the 4 populations in Mangola are heterogeneous culturally and probably hereditarily, however, the suitability of such comparisons for the Mangola population is problematical. With full knowledge, we carried out multivariate analysis separately on six more heritable and six less heritable measurements.

Fig. 7A presents the results of canonical analysis using six more heritable measurements. Discrimination is not particularly sharp, but the Hadza is more distinguishable from the Datoga and Iraqw than either of the latter are from one another and from the Nyamwezi Cluster. The Datoga coincides for the most part with the Iraqw, and the Nyamwezi Cluster overlaps fairly with the Iraqw, and some extent with the Datoga and Hadza. Discrimination is attributed mainly to Function 1, which accounts for 92.5% of the inter-group variation. On Function 1, the Hadza is located very far from the rest, among which separation is obscure. Function 2 explains only 6.0% of inter-group variation and does not distinguish 4 populations significantly. Discriminant loadings in Function 1 are relatively high for stature, ilio-spinal height, biacromial breadth, and head breadth, with the positive sign. The result of D-squares examination corresponds to that of canonical analysis in showing a sharp separation between the Hadza and the remaining populations (Table 4).

Functions 1 and 2 account for 78.3% and 24.5% of the inter-group variation in six less heritable measurements (Fig. 7B). Discrimination is

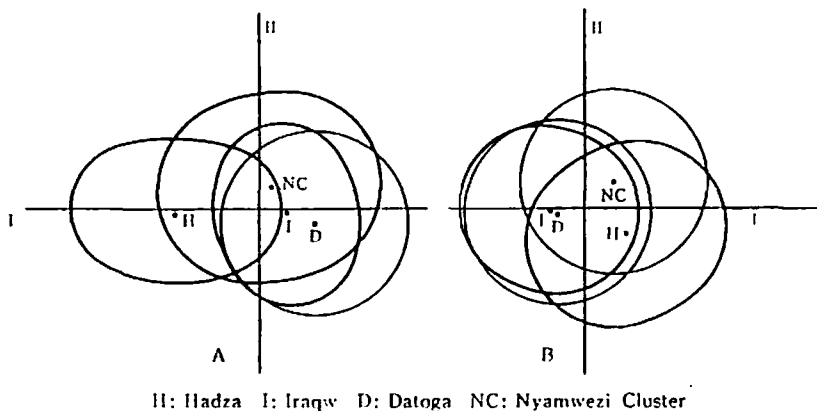

Fig. 7. The centroids and distributions of 4 populations of Mangola on the first two canonical functions computed for 6 more heritable (A) and 6 less heritable anthropometrical variables (B).

Table 4. D² on 6 more heritable measurements and D² on 6 less heritable measurements

		Less heritable measurements			
		Hadza	Iraqw	Datoga	Nyam. C.
More heritable measurements	Hadza		3.18	2.57	1.53
	Iraqw	7.15		0.14	2.58
	Datoga	10.95	0.73		2.19
	Nyamwezi Cluster	5.84	0.47	1.69	

less distinct compared with that in more heritable measurements, that is, all populations overlap each other fairly, particularly the Datoga and Iraqw. The Iraqw and Datoga are separated from the Hadza and Nyamwezi Cluster on Function 1, and either of the latter discriminates from one another on Function 2. Head length and height, with the negative sign, nasal breadth with the positive sign in Function 1, and all but head length with the negative sign in Function 2 have relatively high discriminant loadings. The result by D-squares accords well with that of canonical analysis in that discrimination among 4 populations is not so clear as in more heritable measurements.

Fig. 7A is quite similar to Fig. 6 and both show a better separation than does Fig. 7B. Consequently, it appears that the anthropometrical differences among the Mangola populations might reflect underlying genetic variation. The analysis on less heritable measurements indicates differences between the hunter-gatherer Hadza and the farmer Nyamwezi Cluster on one hand and the agricultural-pastoral Iraqw and the pastoral Datoga on the other. This seems to be attributable to nutritive difference between the former who depend mainly on vegetables for food, and the latter who consume many dairy product. On the other hand, in analysis of more heritable measurements, the Hadza stand apart from any other population, while the Iraqw approach the Datoga and Nyamwezi Cluster, to which the Iraqw have the least D-square.

3. Comparison of the Mangola Populations with the Various Populations in Africa

Canonical analysis on seven measurements was made in a comparison among 14 populations, including 4 of Mangola. As the comparative data are not of individual samples but the mean values for the populations, the mean of within- and among-group covariant matrix for the Mangola populations were substituted for those of populations under comparison.

Functions 1, 2 and 3 account for 42.2%, 35.2% and 10.5% of inter-group variation (Fig.8). Discrimination between the Khoisan and the Bantu-Nilotic populations in Function 1 and that between the Khoisan-Bantu and the Hamitic-Nilotic populations in Function 2 are clearly shown, while there is no good separation in Function 3. In short, the three groups of the Khoisan, Bantu and Hamitic are very significantly distinguishable from one another. Among each linguistic group, the Datoga of the Nilotic, the Iraqw of the Hamitic and the Sandawe of the Khoisan, are the populations closest to the Bantu speaking populations. Discriminant loadings for stature, head length, with the positive sign in Function 1, and those for head breadth, bizygomatic breadth, nasal breadth, with the positive sign in Function 2 are relatively high.

D-squares between both populations of the Khoisan, the Hadza and North Bushmen, and all populations of other linguistic groups, are above 5.0 with the exception of the 4.03 for North Bushmen v.s. Beni Amer

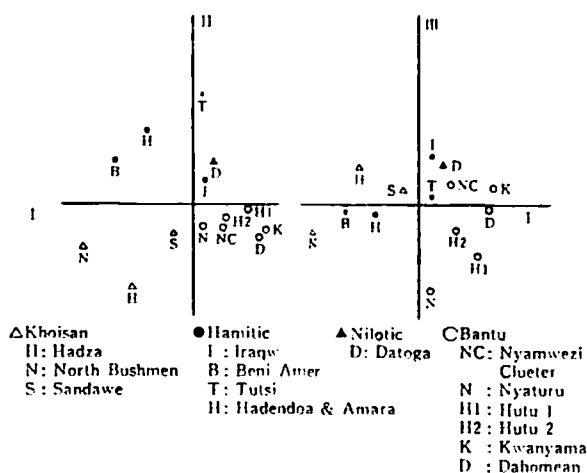

Fig. 8. The centroids of 14 African populations on the first three canonical functions computed for 7 anthropometrical variables.

(Table 5). Among the Khoisan populations, however, the Sandawe show D-squares below 5.0 for almost all populations of other linguistic groups, including one of below 2.0 for the Nyaturu and Nyamwezi Cluster, both of which are the neighbouring Bantu populations of the Sandawe. The majority of D-squares of the Datoga, apart from those for the Hadza and North Bushmen, are below 5.0, the lowest being 0.77 for the Iraqw, followed by 2.35 for the Nyamwezi Cluster. D-squares between the Mawanbi Pygmy and 13 populations used here fall within a range from 20 to 30, the lowest being 19.13 for the North Bushmen, followed by 21.98 for the Hadza.

Putting the results of canonical analysis and D-squares together, the Hadza have the anthropometrical affinity closest to two populations of the Khoisan and are very far from any other population, although the Nyaturu, Nyamwezi Cluster and the Iraqw are relatively close to the Hadza. Not unexpectedly, the population closest to the Nyamwezi Cluster is the Nyaturu, followed by other populations of the Bantu speaking group, and the Iraqw and Datoga are also relatively close to this cluster. It should be noted here, however, that since among 7 measurements used in comparison only 3 are regarded to be more heritable measurements and 4 measurements are the least heritable measurements, the discrimination mentioned above does not always involve genetic differences among the populations.

The Hadza approach mostly to the North Bushmen and also fairly closely resemble the Sandawe, Nyaturu and the Nyamwezi Cluster. According to Barnicot et al. (1972b), the Hadza have intermarried frequently with their neighbours, especially the Isanzu, in the last few generations and probably in their earlier history. Morphological similarities of the Hadza to their neighbours may be attributed to both hereditary and environmental factors. The Hadza and Sandawe may both be reasonably attached to the same racial stock, but the Sandawe have had a rate of mate exchange with neighbouring Bantu tribes higher than that of the Hadza. As a result of this they have come to resemble the

Table 5. Mahalanobis's D^2 on 7 measurements

	Khoisan			Bantu						Nilotic		Hamitic	
	Had.	N.B.	San.	Nay.	N.C.	H.1	H.2	Dah.	Kwa.	Dat.	Ira.	Hade.	B.A. Tut.
Hadza													
North Bushmen	3.43												
Sandawe	3.37	4.92											
Nyaturu	5.11	6.76	0.41										
Nyamwezi Cluster	5.53	9.01	1.42	0.89									
Hutu 1	10.85	11.66	5.08	3.13	2.99								
Hutu 2	7.03	8.47	2.31	1.19	1.33	0.60							
Dahomeans	8.76	12.62	3.28	1.93	1.27	1.75	0.88						
Kwanyama	9.16	14.18	3.44	2.01	0.73	3.03	1.96	0.79					
Datoga	9.22	11.15	4.07	3.82	2.35	4.74	2.97	4.20	3.93				
Iraqw	6.86	9.82	2.71	2.86	2.13	4.89	3.38	3.84	3.94	0.77			
Hadendoa	11.81	8.11	4.61	4.75	6.70	8.56	6.63	9.81	9.70	4.37	4.81		
Beni Amer	7.49	4.03	3.94	4.82	6.86	8.94	6.52	10.43	10.91	5.06	4.88	1.09	
Tutsi	16.91	14.34	8.58	7.99	7.42	7.17	7.03	9.81	9.77	3.06	4.13	4.01	5.06

Hutu 1: higher altitude Hutu, Hutu 2: lower altitude Hutu, Hadendoa: Hadendoa and Amara

Bantu more than the Hadza do.

As Barnicot et al. (1972b) pointed out, in discussion of physical characters in a population as small as the Hadza, genetic drift should be taken into account. For example, the wide variation of some heritable traits, such as dermatoglyphics or blood group, among the Bushmen and Pygmy small populations may be explained by this effect. Granting it to be true that genetic drift has contributed to the gene pool of the Hadza, however, it is still reasonable to suppose that the Hadza possess some metrical traits characteristic of the Khoisan.

On the other hand, the Iraqw bear a close resemblance to the Nyamwezi Cluster as well as to the Hamitic in more heritable measurements but are not typical of either the Bantu or the Hamite. This may be attributed to mate exchange among populations in Mangola. Inter-marriage between the Iraqw and Datoga and between the Iraqw and Bantu tribes was confirmed by Tomikawa (1970) and Wazaki (1970). The Iraqw seem to have received Negro genes from both the Bantu tribes and Datoga.

MEASUREMENTS OF DENTITION AND DENTAL ARCH

1. Tooth Size

Dental impressions were taken on 11 males of the Hadza, 21 of the Iraqw and 9 of the Datoga. From dental impressions, plaster casts of the palate and dental arch were subsequently made. Based on these plaster casts, the mesiodistal crown diameters were measured. Nine of 21 Iraqw and 6 of 9 Datoga samples lost the lower medial incisors because of artificial extraction. Table 6 gives means and standard deviations of each tooth for 3 populations and those for the Caucasians and Negroes.

Principal component analysis was carried out to analyze affinities among 5 populations (Fig.9). Component 1, which explains 57.0% of inter-group variation, separates the Hadza-Datoga from the Iraqw-Caucasian-Negro group. The anterior teeth of the former and the posterior teeth of the latter group are relatively large respectively. The Hadza and Negroes are separated from the rest in Component 2, which accounts for 29.6% of inter-group variation and relates the size of incisors: the Hadza-Negro group having small incisors and the rest large ones. As is

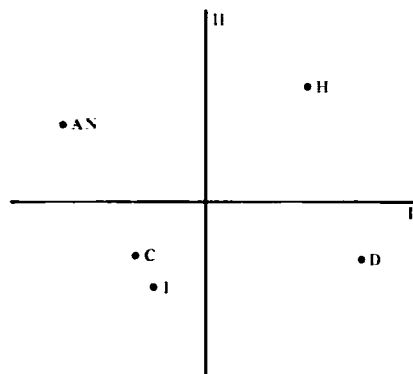

Fig. 9. The centroids of 5 populations on the first two principal components computed for the mesiodistal crown diameters.

H: Hadza I: Iraqw D: Datoga C: Caucasians AN: American Negroes

Table 6. Means and standard deviations of mesiodistal crown diameters

Tooth	Hadza	Datoga	Iraqw	Caucasian	American Negroes
	n=11	n= 9	n=21	n=26	n=22
I ¹	9.4 <i>0.4680</i>	9.1 <i>0.6137</i>	9.1 <i>0.5543</i>	8.6 <i>0.6142</i>	8.9 <i>0.4765</i>
I ²	7.9 <i>0.6681</i>	7.2 <i>0.4158</i>	7.3 <i>0.6089</i>	6.5 <i>0.6033</i>	7.1 <i>0.7613</i>
\bar{C}	9.0 <i>0.4264</i>	8.3 <i>0.6236</i>	8.0 <i>0.3587</i>	7.8 <i>0.4839</i>	8.2 <i>0.4029</i>
P ¹	8.0 <i>0.3693</i>	7.4 <i>0.4582</i>	7.5 <i>0.4750</i>	7.1 <i>0.3952</i>	7.6 <i>0.4758</i>
P ²	7.4 <i>0.4312</i>	6.8 <i>0.6455</i>	7.1 <i>0.5096</i>	6.7 <i>0.4712</i>	7.2 <i>0.5017</i>
M ¹	12.2 <i>0.3215</i>	11.0 <i>0.4264</i>	11.2 <i>0.5890</i>	10.7 <i>0.6618</i>	11.0 <i>0.6155</i>
M ²	11.0 <i>0.7524</i>	9.9 <i>0.3143</i>	10.6 <i>0.6415</i>	10.2 <i>0.7185</i>	10.6 <i>0.5828</i>
I ₁	6.0 <i>0.4500</i>	5.7* <i>0.4714</i>	5.8** <i>0.4310</i>	5.4 <i>0.4487</i>	5.5 <i>0.3415</i>
I ₂	6.5 <i>0.6396</i>	6.1 <i>0.6983</i>	6.4 <i>0.4165</i>	5.9 <i>0.4673</i>	6.1 <i>0.3920</i>
\bar{C}	7.8 <i>0.3857</i>	7.1 <i>0.4969</i>	7.2 <i>0.6607</i>	6.8 <i>0.4539</i>	7.2 <i>0.4707</i>
P ₁	7.8 <i>0.4938</i>	7.1 <i>0.1572</i>	7.5 <i>0.5118</i>	7.1 <i>0.4031</i>	7.7 <i>0.4956</i>
P ₂	7.8 <i>0.5786</i>	7.1 <i>0.5152</i>	7.6 <i>0.4055</i>	7.2 <i>0.4666</i>	7.7 <i>0.5826</i>
M ₁	12.4 <i>0.6428</i>	11.3 <i>0.6286</i>	11.7 <i>0.6089</i>	11.2 <i>0.7312</i>	12.0 <i>0.6606</i>
M ₂	11.7 <i>0.4454</i>	10.7 <i>0.3334</i>	11.1 <i>0.6658</i>	10.8 <i>0.7344</i>	11.4 <i>0.7299</i>

* n=3, ** n=12, Italics show standard deviations.

quite evident in Fig. 10, the Iraqw and Caucasians represent one cluster, to which the Negroes merge, and the Hadza and Datoga another cluster.

2. Size of Dental Arch

Three sets of measurement were made on the casts of dental arcades (Table 7): (1) external coronal arch distances of the upper C-M² and lower \bar{C} -M₁ (the maximum distance between the buccal surface of a tooth on one side and the corresponding tooth on the other side); (2) minimum internal coronal arch distances of the upper C-M² and lower \bar{C} -M₁ (similar to the first set of measurement except that minimum distance from the lingual or palatal surfaces of the teeth were measured); (3) mid-sagittal arch length of the upper and lower C-M₂ (distances in the mid-line from a line joining the most distal points of the teeth being measured to the most anterior point of the incisors). These sets are the same as those made on casts of adult Bushmen, Bantu and Whites by Van Reenen (1964).

Penrose's size and shape distances were calculated among 6 populations: the Hadza, Iraqw, Datoga, Bushmen, Bantu and Whites (Table 8). In regard to the size component, larger distance is found between the Iraqw-Bantu-Whites and the Hadza-Datoga-Bushmen group. In contrast smaller distances are shown between the Iraqw and Whites, and

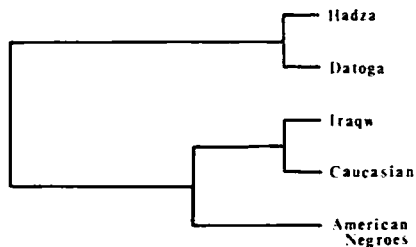

Fig. 10. Clustering of 5 populations from Penrose's shape distances based on the mesiodistal crown measurements.

Table 7. Three sets of measurements of dental arcades

	Hadza	Datoga	Iraqw	Bushman	Bantu	Whites
	n=11	n= 9	n=21	n=16	n=13	n=21
External coronal arch distance						
M^2-M^2	61.9	61.8	64.7	60.8	63.8	64.4
M^1-M^1	58.8	58.1	60.6	57.1	60.3	59.5
P^2-P^2	51.7	50.6	53.8	50.5	54.3	53.0
P^1-P^1	46.8	46.2	48.3	45.4	49.3	47.6
\bar{C}	39.2	38.4	40.5	37.7	41.8	40.5
M_3-M_3	62.2	64.2	64.8	61.5	65.2	66.0
M_2-M_2	58.6	58.7	60.8	58.4	62.0	62.5
M_1-M_1	54.1	52.1	55.2	53.7	57.3	56.5
P_2-P_2	44.5	43.9	46.7	43.3	48.2	47.8
P_1-P_1	39.7	37.8	40.3	37.7	42.2	41.5
\bar{C}	31.6	28.6	30.9	29.5	32.5	32.0
Internal coronal arch distance						
M^2-M^2	39.6	41.2	42.1	39.1	40.6	42.0
M^1-M^1	36.3	36.3	37.9	35.7	36.5	37.0
P^2-P^2	34.5	34.4	35.4	34.1	34.8	34.0
P^1-P^1	28.7	28.7	30.0	28.4	30.3	28.5
\bar{C}	24.1	24.4	25.2	24.2	26.2	25.0
M_3-M_3	42.4	44.8	43.7	41.6	43.4	46.4
M_2-M_2	38.2	39.1	39.4	37.7	39.6	41.4
M_1-M_1	32.3	32.0	34.1	32.7	33.6	34.7
P_2-P_2	29.6	28.7	30.9	29.8	31.2	31.1
P_1-P_1	25.2	23.6	25.6	24.7	26.8	26.5
\bar{C}	18.0	16.1	17.7	17.5	17.5	18.9
Midsagittal arch length						
M^2-M^2	47.0	48.2	48.6	45.5	50.8	48.5
M^1-M^1	37.3	39.1	38.9	36.1	40.8	39.4
P^2-P^2	26.5	28.2	28.6	26.2	29.8	28.8
P^1-P^1	20.7	22.2	22.3	20.1	23.1	22.2
\bar{C}	14.6	15.7	15.3	13.7	16.3	14.9
M_2-M_2	43.6	42.9	45.4	42.1	47.5	45.4
M_1-M_1	33.1	33.1	34.7	31.9	37.1	32.8
P_2-P_2	22.5	22.6	23.9	21.7	25.8	24.1
P_1-P_1	15.9	15.9	16.6	15.3	18.8	17.0
\bar{C}	10.7	11.3	11.1	9.7	11.5	10.2

Table 8. Penrose's size and shape distances of three sets of measurements of dental arcades

		Size distance					
		Hadza	Datoga	Iraqw	Bushman	Bantu	Whites
Shape distance	Hadza		0.02	11.04	4.65	29.13	14.28
	Datoga	11.89		12.01	4.05	30.70	15.38
	Iraqw	3.24	7.92		30.00	4.31	0.21
	Bushman	2.77	11.03	4.32		57.04	35.21
	Bantu	8.33	15.77	6.80	13.25		2.62
	Whites	7.42	15.22	6.00	8.40	10.81	

also between the Hadza and Datoga. The shape distance gives a quite different picture from that of the size distance. Relatively small distance is recognized among the Hadza, Iraqw and Bushmen, while the distance between the Hadza and Datoga is fairly large.

The findings in measurements of dentition and dental arch suggest only close affinities of the Iraqw to the Whites.

OSTEOLOGY

1. Gishimangeda Specimens

The crania available for measurements were those of three adult males and five adult females (Tables 9 and 10).

In average, cranial index is 73.0 for males and 71.4 for females, both belonging to dolichocran. The length-height index is 71.2 for males and 73.7 for females indicating that both sexes are orthocranic, and the breadth-height index for all materials, except one metriocranic male, is acrocranic; its mean is 97.6 for males and 102.4 for females.

Seven crania are so well preserved as to be available for the total facial and upper facial indices. Five of those belong to either hyperlepto- or leptoprosope, and to either hyperlepten or lepten type. Two female crania fall into either meso- or euryprosope and both into mesen. In average, the males are hyperleptoprosope (95.2) and lepten (56.0), and the females are leptoprosope (93.3) and lepten (56.3). The orbit varies from high to low, while the mean of the orbital index is hypsiconchic (88.0) for males and mesoconchic (81.1) for females. The nasal index is also variable; there are all grades from leptorrhine to hyperchamaerrhine. Its mean for males (51.3) and females (56.1) belong to chamaerrhine category. Alveolar projection varies from ultraprognathism to orthoprognathism, although 5 of 7 specimens are prognathic. The alveolar index falls into all grades from brachyuranic to dolichouranic type.

Gishimangeda specimens reveal a great range of inter-group variation not in cranial vault but in facial part. They vary between the poles of chamaerrhine-prognathic (G5) and leptorrhine-orthognathic (G1). The extraction of the teeth is not found in any specimen.

As to the postcranial skeletons, the extremity bones are generally slender; the caliber indices of humerus (male 17.5, female 17.2), radius (male 16.7, female 15.6), ulna (male 15.0, female 15.1) and femur (female 17.4) are small (Table 11). The femora of both sexes are platymeric not in the pilastric index (male 114.9, female 111.7) but in the platymeric index (male 79.3, female 75.6). The degree of flatness of tibia is

Table 9. Craniometrical data of the Gishimangeda and Sechikuencho skulls

	Gishimangeda								Sechikuencho	
	Male			Female					Male	
	1 Adult	2 Mat.	02 Adult	3 Mat.	4 Mat.	5 Adult	6 Mat.	01 Mat.	1 Mat.	3 Mat.
1. Max. length	189	179	193	180	(174)	184	176	180		184
5. N-Ba length	102	93	102	95		97	96	101		99
8. Max. breadth	140	137	132	135	138	125	126	132		141
17. Ba-Br height	138	130	131	134		130	133	133		129
23. Horiz. C.	534	518	521	507		505	486	500		516
24. Trans. Arc	308	279	296	314		307	296	297		302
25. Sag. Arc	379		375	383		379	352	361		365
45. Bizyg. breadth	135	135	(130)	118	(116)	119	(120)	123		133
46. Mid. Fac. breadth	101	91	94	92	92	101	(93)	93	97	90
47. Fac. height	129	133	119	129		(107)	110	(101)	120	126
48. Up. Fac. height	75	76	73	75		63	69	63	69	(71)
51. Orb. breadth	44	44	43	39		43	43	42	44	46
52. Orb. height	34	34	34	34		32	32	32	34	34
54. Nas. breadth	27	29	24	26	27	26	28	25	24	25
55. Nas. height	52	52	52	54		45	45	49	54	50
60. Alv. length	53	64	51	48	(50)	52	(56)	49		
61. Alv. breadth	63	59	63	59	(52)	62	(55)	56		61

Table 10. Cranial indices and angle of the Gishimangeda and Sechikuencho skulls

		G1	G2	G02	G3	G4	G5	G6	G01	S1	S3
Cranial index	hyperdolichocranic			68.4			67.9				
	dolichocranic	74.1						71.6	73.3		
	mesocranic brachyranic		76.5		75.0	(79.3)					76.6
Length-height index	chamaecranic			67.9							
	orthocranic	73.0	72.6		74.4		70.7		73.9		70.1
	hypsicranic							75.6			
Breadth-height index	tapeniocranic										91.5
	metriocranic		94.9								
	acrocranic	98.6		99.2	99.3		104.0	105.6	100.8		
Total facial index	euryprosopic								(82.1)		83.5
	mesoprosopic						89.9				
	leptoprosopic			(91.5)				91.7			
	hyperleptoprosopic	95.6	98.5		109.3						
Upper facial index	euryen										45.9
	mesen						52.9		51.2		
	lepten	55.6	56.3	(56.2)				(57.5)			
	hyperlepten				63.6						
Orbital index	chamaeconchic						74.4	74.4			73.9
	mesoconchic	77.2	77.2	79.1					76.2	77.2	
	hypsiconchic				87.2						
Nasal index	hyperchamaerrhine							62.2			
	chamaerrhine	51.9	55.8				57.8		51.0		50.0
	mesorrhine				48.2						
	leptorrhine			46.2						44.4	
Alveolar index	dolichouranic		92.2			(104.0)		(98.2)			
	mesouranic								114.3		
	brachyuranic	118.9		123.5	122.9		119.2				138.6
Alveolar profil angle	ultraprognathic							53			
	hyperprognathic	68					63				
	prognathic		75						73		77
	mesognathic			84							
	orthognathic				85						

Table 11. Measurements and indices of extremities and estimated stature

Humerus	G1♂	G2♂	G-H-01♂	G3♀	G5♀	G-H-02♀	S3♂								
Max. length	352	352	342	303	284	319	290								
Caliber index	17.9	17.0	17.5	16.2	18.3	17.2	21.4								
Stature	176.9	176.9	174.0				162.9								
Radius	G1♂	G-R-02♂	G-R-03♂	G5♀	G-R-01♀	G-R-04♀									
Max. length	255	268	266	224	253	240									
Caliber index	17.6	15.9	16.6	15.9	15.5	15.4									
Stature	174.4		173.7	164.1		160.5									
Ulna	G1♂	G-U-01♂	G-U-02♂	G5♀	S2♂	S3♂									
Max. length	273	287	286	246	300	247									
Caliber index	17.1	14.0	14.0	14.7	14.3	16.2									
Stature	174.6		174.6	178.8											
Femur	G2♂	G-F-01♂	G-F-02♂	G-F-04♂	G-F-05♂	G3♀	G4♀	G5♀	G6♀	G-F-03♀	S1♂	S2♂	S3♂	S4♂	
Max. length						426	407	447						420	
Caliber index						16.2	19.0	16.9						21.9	
Pilastric index	108.0	120.8	107.4	119.2	119.2	104.8	117.4	113.6	122.7	100.0	100.0	130.8	119.2	126.9	
Platymetric index	80.0	79.4	87.1	73.5	76.5	74.1	82.1	78.6	67.7		67.7	82.4	90.0		
Stature						156.9	152.6	161.7							
Tibia	G2♂	G-T-01♂	G-T-02♂	G-T-03♂	G-T-05♂	G4♀	G5♀	G-T-04♀	S1♂	S2♂	S3♂				
Max. length					408	356		383				356			
Platycnemic index*	73.3		79.3	77.4	64.7	70.4		76.0	82.1	65.7	57.6				
Platycnemic index**	62.9	61.1	78.1	70.6	63.2	76.7	65.6	81.5	66.7	64.1	57.1				
Stature					174.7	166.5									

* at the middle, ** at the foramen nutricium

insignificant; the platycnemic index is 73.7 for males and 73.2 for females at the middle, and 67.2 (mesocnemic) for males and 74.6 (eurycnemic) for females at foramen nutricium. Stature estimated from the long bones falls into a range from 173.7cm to 176.9cm for 8 males and that from 152.6cm to 166.5cm for 7 females. Its mean is 175.0cm for males and 160.7cm for females.

It is noteworthy that frequencies of perforation of coronoid-olecranon septum of humerus are remarkably high in this series: 1 of 3 males (33.3%) and 5 of 6 females (83.3%). The frequency of 66.7% in total of both sexes is higher than those for the Negroes, Negritos, Wedda and American Indians, all of whom are known as the populations with high frequencies of this perforation.

2. Sechikuencho Specimens

Each grave contains an adult male. Only one specimen of 4 males, S3, is so well preserved as to be available completely for cranial measurements. The craniometrical features of S3 are as follows (Tables 9 and 10). The cranial index is of mesocran close to dolichocran, the length-height index is orthocranic, and the breadth-height index is tapeniocranic. The face is short; the total facial index belongs to euryprosop, and the upper facial index to euryen. The orbit is low (chamaeconchic), and nose and palate is wide (chamaerhinc and brachyuranic). Alveolar projection is moderately prognathic. Apart from S3, S1 is the specimen available for facial measurements and observation. It has mesoconchic orbit, leptorrhinc nose, a metopic suture and mandibular torus. The indices of the facial part show great variability within Sechikuencho series, while the extraction of the lower medial incisors is found in all of 4 specimens.

The measurements of postcranial bones were made almost completely on S3 and partially on the rest (Table 11). Caliber indices of the extremity bones are large for S3 but a little small for S2. The pilastric and platymeric indices of femur, and the platycnemic indices at the middle and at foramen nutricium of tibia were calculated for 3 or 4 specimens. In average, the pilastric index is 119.2, the platymeric index 80.0 (platymeric), the platycnemic index at the middle 68.5, and the platycnemic index at foramen nutricium 62.8 (platycnemic). Stature estimated from the maximum length of femur of S3 is 161.0cm and that from ulna of S2 178.8cm. Healed fracture of the right radius is found in S3.

3. Multivariate Analysis

On 8 cranial measurements of the maximum cranial length, maximum cranial breadth, basion-bregma height, bizygomatic breadth, upper facial height, orbital height, nasal breadth and height, the Gishimangeda and Sechikuencho males were compared with the various cranial series from Africa by principal component analysis. In addition to the mean of the Gishimangeda series (GX), the individual skulls of Gishimangeda (G1,2,02) and Sechikuencho (S3) were also included in the analysis. The main comparative series were the mean (MX) and the individual skulls (M2,3,9,10,12,15) from "Masai grave" reported by Bräuer (1976). The other comparative data were taken from the following series: Gizeh (GZ), Zulu (ZU1), Bushmen (BU1) by Howells (1973); Naqada (NA) by Crichton (1966); Zulu (ZU2), Sotho (SO), Xosa (XO), Bushmen (BU2), Hottentot (HO) by Rightmire (1970).

Components 1, 2 and 3 account for 40.6%, 24.6% and 18.0% of inter-group variation respectively (Fig.11). Component 1 separates a group including the mean and all individuals of Gishimangeda and "Masai grave" series with exception of M9, Gizeh and Nagada, from the rest, among which Bushmen 1 is located furthestmost from the Gishimangeda

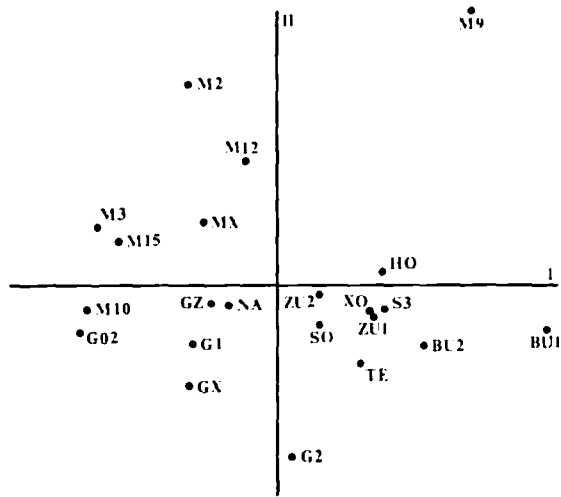

Fig. 11. The centroids of 13 African populations and 9 individual skulls of Gishimangeda and "Masai-grave" on the first two principal components computed for 8 cranial measurements. For the abbreviations see the text.

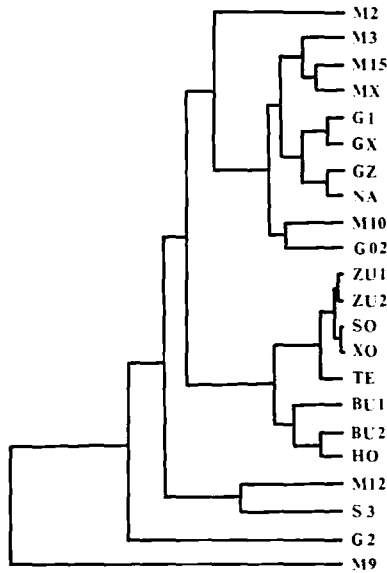

Fig. 12. Clustering of 13 populations and 9 individual skulls of Gishimangeda and "Masai-grave" from Penrose's shape distances based on 8 cranial measurements. For the abbreviations see the text.

group, followed by Bushmen 2. Sechikuencho (S3), Zulu 1 and 2, Sotho, Teita and Xosa represent one cluster. Factor loadings are relatively high for the positive value in nasal breadth and for the minus value in facial height. Component 2, of which large factor loadings are shown for the positive values in head length and upper facial height and the minus value in orbital height, discriminates the "Masai grave" series, except M10, from the rest. There seems to be no clearly discernible overall tendency on Component 3, though S3 and M12 are located on one extreme, and G2 and M9 on the opposite extreme. Component 3 relates facial height and nasal breadth positively, and head breadth and orbital height negatively.

The result of clustering of all cranial series (Fig.12) is highly consistent with that on Component 1; the Gishimangeda series are close to "Masai grave" series, both and Gizeh-Nagada representing one cluster, while S3, the only specimen available for comparison among the Sechikuencho series, has the closest affinity to M12 which has an extreme position in the range of the "Masai grave" series.

THE EARLIER INHABITANTS IN MANGOLA VILLAGE

Bräuer (1976), for the following reasons, used the term "Masai grave" skeletal series for the human remains which were excavated by Kohl-Larsen.

All the graves, except one, contain men who generally died between 50 and 60 years of age. ...A possible explanation for this remarkable sex and age distribution could be found in the practice of the Masai to bury only older men and medicine men. The extraction of the lower medial incisors, which was very common and which is known as 'Masai-deformation', can also serve as an indication of the relationship to the Masai. ...The skeletal material shows the strongest affinities to Jebel Moya, Gamble's Cave and Gizeh, which indicates a hybrid population with Mediterranean as well as Negroid elements. The assumed indications of the relationship of these skeletons to the Masai are more probable since these people have arrived in this region by the 17th or 18th century".

The ablation of the lower medial incisors, however, is prevalent in the Masai as well as in the Iraaq and Datoga, all of whom are more of less hybrid populations between the Mediterraneans and the Negroes. Accordingly, for all that the "Masai-grave" and Sechikuencho cranial series are characterised by the removal of the same teeth and that they craniometrically approach to the Masai, it would be premature to put the Masai up for the only candidate for the tribe most closely related to these skeletal populations.

The Gishimangeda skeletal series represent the Mangola villagers who died several centuries ago. They are quite different from the "Masai-grave" series in showing neither unbalance of sex and age distribution nor practice of tooth removal, while these two series show common cranial morphology.

Burial cairns are widely distributed in East Africa and are still made by some tribes today. Some crania whose lower medial incisors were extracted were unearthed from the prehistoric cairns in northern Tanzania and southern Kenya.

A human skeleton was excavated from the cairn at Engaruka, located at the foot of the Rift scarp south of Lake Natron. The date of this cairn is believed to be around the 16th century. Prof. P. Tobias, who examined this skull briefly, expressed an interim opinion that it belongs to a young adult male with negroid features and that the lower medial incisors had been ablated (Sasoon, 1966). At the Makalia Burial Site and Willey's

Kopje, the same type of burial mound and the practice of extracting the lower medial incisors link the burial with that of Engaruka. The graves at the Makalia Burial Site and Willey's Kopje, which yield the skulls with "Europid" morphology (Bräuer, 1978a), can be dated probably back to the beginning of the 1st millenium of the Christian Era. On the other hand, a skull from the Nakuru Burial Site, which may be dated to the 2nd millenium of the Christian Era, has not had the lower medial incisors extracted. It is essentially non-negroid, although the forehead does show the negro characteristic of a single central frontal boss (Leakey, 1931). Therefore, it does not always follow that the burial cairns, the practice of removing the lower medial incisors and the cranial features characteristic of the Mediterraneans link together.

The analysis which used 8 cranial measurements shows that the Gishimangeda series are close to the "Masai-grave" series, Gizeh and Nagada, all of which are very far from the Khoisan group and also different from the Bantu group. It should be noted, however, that among the Gishimangeda series there are individuals showing the Negro characteristic of prognathism and frontal boss. They are essentially hybrid population between the Mediterraneans and the Negroes, but are more close to the latter compared with the "Masai-grave" series.

The populations with mixed physical traits of the Mediterranean and Negro are the Hamitic and Nilotic peoples in Mangola. The Iraqw investigated as a representative for the Hamitic bear a close resemblance in anthropometrical and odontometrical comparison to the other members of the Hamitic or Caucasians as well as to the Bantu speakers. This accords well with the statement by Allison et al. (1954) that, so far as blood group frequencies show, the Iraqw are neither the typical Bantu nor the typical Hamitic people. In dermatoglyphics and physical measurements, on the other hand, the Datoga of the Nilotic occupy an intermediate position between the Caucasians and Negroes, but they are closer to the latter, while the Datoga represent one cluster with the Hadza and differ significantly from the Iraqw-Caucasian-Negro group in size of teeth and of dental arches.

Based on reexamination of human crania from the prehistoric sites in the Eastern Rift Valley of Kenya, Rightmire (1975) assumed that many of these skulls can certainly be excluded from probable member of the Egyptian population and that much firmer ties can be established with one of the several African Negro groups, especially with Nilotic Negrid. From linguistic evidence, he has drawn inferences that early Southern Nilotic as well as other language such as Cushitic was obviously spoken in this region for a long time, perhaps several thousand years before the Christian Era. He has given further attention to the pre-Masai people in oral history of the living Masai. According to Jacobs's study quoted by Rightmire, the pre-Masai people referred to as "Ilumbua" by the Masai, said to have been dispersed during the 1st millenium of the Christian Era by a later people called "Iltatua" who were in turn driven out of the area before 1960 A.D. by the Masai. Jacobs considered either the Datoga or the Iraqw speakers of northern Tanzania to be the likeliest living representatives of pre-Masai people.

Putting our results and these studies together, we can suggest that the occupant of the Gishimangeda cave several centuries ago were the Nilotic or the Cushitic peoples, probably the former because of the morphological features of Gishimangeda skeletal series.

The history of occupation in Mangola village can be traced back to an early stage of Later Stone Age by human remains from the Mumba Rock Shelter and even further to the Upper Pleistocene by "Eyasi skull" (Fig.1). Reviewing the Mumba Rock Shelter crania which were collected by Kohl-Larsen in 1934/38, Bräuer (1978b,1980) found that they have Negroid

size and shape characteristics. He concluded that "during long period of the Later Stone Age, not only Caucasoid but also Negroid populations may have been present in East Africa, and the wide dispersion of Khoisanoid populations, until recently assumed to have reached as far as Tanzania and Kenya at that time, is on the whole uncertain, even improbable."

The antiquity and wide distribution of the Khoisan stock in East Africa, who were driven to South Africa by incoming Caucasoid and Negroid later in time, have been pointed out by several authors. No trace of early Khoisanoid, however, exists in East Africa, except a skull (Homa 4) found together with a typical Wilton industry by Leakey (1935). Early settlement of the members of Khoisan group in this region has been deduced from linguistic and ecological evidences, namely, the existence of the Hadza and Sandawe who have the languages with clicks, and the fact that the Hadza today still lead a life of hunting and gathering as the Bushmen in the Kalahari. Other evidences are physical traits of the Sandawe: distinct affinities of their skulls to the Hottentot skulls described by Virchow in 1895, and physical similarity of living Sandawe to the Hottentot revealed by Trevor (1947).

The Hadza differ significantly from the Iraqw, Datoga and Bantu speakers not in dermatoglyphics, tooth size and dental arch measurements but in physical measurements. Hiernaux & Hartono (1980) pointed out that the Hadza are quite average in their general morphology among the African populations and also that they have physical built adapted to a physically active life in a hot climate, such as little fat and big muscles. Are the distinct Bushmanoid affinities of the Hadza, as far as the anthropometrical analysis shows, attributable to their subsistence activities in a hot climate? The life of hunting and gathering in a hot climate seems to have an effect on body built but not on head form.

Recently, several authors have been doubtful of the connection between the Hadza and Bushman languages, insisting that resemblances between the Hadza and the Khoisan should prove to be superficial. As stated before, Tucker (1967) suggested a remote connection of the Hadza language with the Cushitic language of Northeastern Africa. But there is no anthropometrical data showing similarities between the Hadza and Cushitic peoples including the Iraqw. This paper concludes that the Hadza can not conclusively be attached to any definite people from both linguistic and physical aspects.

ACKNOWLEDGEMENTS

We are most grateful to the Director of the Antiquities Division, Ministry of National Culture and Youth of Tanzania, for granting permission of our research in Mangola, and to the Director of the National Museum of Tanzania for providing laboratory accomodation in the Museum during our stay in Dar es Salaam for the investigation of human remains. We wish to extend our appreciation to Prof. J. Itani of Kyoto University, the Director of the Kyoto University Africa Scientific Expedition 1967, for affording us an opportunity to make researches in Tanzania and giving us kind advice. We are deeply indebted to Prof. T. Kamei of Kyoto University, Prof. M. Tomikawa of Tokyo Foreign Language University, and Prof. Y. Wazaki of Toyama University, for their encouragement and assistance to us in our study of Mangola. We would like to express our gratitude to Prof. K. Kigoshi of Gakushuin University who presented the radiocarbon date for the Gishimangeda cave, and to Mr. A. Tagaya of Osaka City University, who assisted us in the statistical calculations. This study was aided in part by a grant from Wenner-Gren Foundation for Anthropological Research, No. 2258.

REFERENCES

- Allison, A.C., E.W.Ikin, and A.E.Mourant, 1954. Further observations on blood groups in some East African tribes. Journal of Royal Anthropological Institute, 84: 158-162.
- Barnicot, N.A., F.J.Bennett, J.C.Woodburn, R.R.E.Pilkington, and A.J.Antonis, 1972a. Blood pressures and serum cholesterol in the Hadza of Tanzania. Human Biology, 44: 87-116.
- Barnicot, N.A., D.P.Mukherjee, J.C.Woodburn, and E.J.Bennett, 1972b. Dermatoglyphics of the Hadza of Tanzania. Human Biology, 44: 621-648.
- Barnicot, N.A., J.C.Woodburn, M.S.Pereira, and B.E.Henderson, 1973. Studies on viral, bacterial, rickettsial and treponemal diseases in the Hadza of Tanzania and a note on injuries. Human Biology, 45: 243-272.
- Barnicot, N.A. and J.C.Woodburn, 1975. Colour-blindness and sensitivity to PTC in Hadza. Annals of Human Biology, 47: 61-68.
- Bennett, F.J., I.G.Kagan, N.A.Barnicot, and J.C.Woodburn, 1970. Helminth and protozoal parasites of the Hadza of Tanzania. Transactions of the Royal Society of Tropical Medicine and Hygiene, 64: 857-880.
- Bräuer, G., 1976. Morphological and multivariate analysis of human skeletons from Iron Age graves northeast of Lake Eyasi (Tanzania). Homo, 27: 185-196.
- Bräuer, G., 1978a. The morphological differentiation of anatomically modern man in Africa, with special regard to recent finds from East Africa. Zeitschrift für Morphologie und Anthropologie, 69: 266-292.
- Bräuer, G., 1978b. Menschliche Skelette aus der Mumba-Höhle (Nord-Tanzania) und ihre Bedeutung für die Rassengeschichte Ostafrikas. Homo, 29: 24-40.
- Bräuer, G., 1980. Human skeletal remains from Mumba rock shelter, northern Tanzania. American Journal of Physical Anthropology, 52: 71-84.
- Crichton, J.M., 1966. A multiple discriminant analysis of Egyptian and African Negro crania. Papers of the Peabody Museum of Archaeology and Ethnology, Harvard University, 57: 47-67.
- Hiernaux, J., 1963. Heredity and environment: Their influence on human morphology. A comparison of two independent lines of study. American Journal of Physical Anthropology, 21: 575-589.
- Hiernaux, J., 1968. La diversité Humaine en Afrique Subsaharienne. Recherches Biologique. Editions Inst. Sociol. de l'Université Libre de Bruxelles, Bruxelles. (quoted from Passarello & Vecchi, 1979)
- Hiernaux, J. and D.B.Hartono, 1980. Physical measurements of the adult Hadza of Tanzania. Annals of Human Biology, 7: 339-346.
- Howells, W.W., 1973. Cranial Variation in Man. Papers of the Peabody Museum of Archaeology and Ethnology, Harvard University, 67.
- Ikeda, J., 1977. Racial affinities of the Hadza and the Iraqw: A multivariate analysis of physical measurements. In: Physical Anthropology, Evolution and Primates, T.Kato, S.Nakao and T.Umesao (eds.), Chuokoronsha, Tokyo, pp. 57-76. (in Japanese)
- Leakey, L.S.B., 1931. The Stone Age Cultures of Kenya Colony. Cambridge University Press, Cambridge.
- Leakey, L.S.B., 1935. The Stone Age Races of Kenya. 2nd ed., Oxford University Press, London.
- McHenry, H. and E.Giles, 1971. Morphological variation and heritability in three Melanesian populations: A multivariate approach. American Journal of Physical Anthropology, 35: 241-254.
- Passarello, P. and F.Vecchi, 1979. Morphological relationships between 65 East African populations. A correspondence analysis. Rivista di

- Antropologia, 60: 105-112.
- Pons, J. und M. Fusté, 1962. Die Verwendung der Hautleistenbefunde zur Analyse der rassischen Zusammensetzung in Gran Canaria (Kanarische Inseln, Spanien). Anthropologische Anzeiger, 25: 179-184.
- Rightmire, G.P., 1970. Iron Age skulls from Southern Africa reassessed by multiple discriminant analysis. American Journal of Physical Anthropology, 33: 147-168.
- Rightmire, G.P., 1975. New studies of Post-Pleistocene human skeletal remains from the Rift Valley, Kenya. American Journal of Physical Anthropology, 42: 351-370.
- Roberts, D.F. and S.S. Papiha, 1978. Genetic polymorphism in Sukuma from Tanzania. Anthropologie, 82: 565-574.
- Roberts, D.F., S.K. al-Agidi and K. Vincent, 1979. Immunoglobulin levels and genetic polymorphisms in the Sukuma of Tanzania. Annals of Human Biology, 6: 105-110.
- Sasoon, H., 1966. Engaruka: Excavation during 1964. Azania, 1: 79-99.
- Stevens, A., J. Morissette, J.C. Woodburn, and F.J. Bennett, 1977. The inbreeding coefficients of Hadza. Annals of Human Biology, 4: 219-245.
- Tomikawa, M., 1970. The distribution and the migrations of the Datoga tribe. The sociological distinctions of the Datoga society in the Mangola area. Kyoto University African Studies, 5: 1-46.
- Tōmita, K., 1966. The sources of food for the Hadzapi tribe. The life of a hunting tribe in East Africa. Kyoto University African Studies, 1: 157-171.
- Trevor, J.C., 1947. The physical characters of the Sandawe. Journal of Royal Anthropological Institute, 77: 61-77.
- Tucker, A.N., 1967. Fringe Cushitic: An experiment in typological comparison. Bulletin of School of Oriental and African Studies, 30: 655-680. (quoted from Barnicot et al., 1972b)
- Van Reenen, J.F., 1964. Dentition, jaws and palate of the Kalahari Bushman. Part I. The Journal of the Dental Association of South Africa, 19: 1-15.
- Wazaki, Y., 1970. On the tribes of Mangola village. Kyoto University African Studies, 5: 47-79.
- Woodburn, J.C., 1968a. An introduction to Hadza ecology. In: Man the Hunter, R.B. Lee and I. DeVore (eds.), Aldine, Chicago, pp. 49-55.
- Woodburn, J.C., 1968b. Stability and flexibility in Hadza residential groupings. In: Man the Hunter, R.B. Lee and I. DeVore (eds.), Aldine, Chicago, pp. 103-110.
- Woodburn, J.C., 1972. Ecology, nomadic movement and the composition of the local group among hunters and gatherers: an East African example and its implications. In: Man, Settlement and Urbanism, P.J. Ucko, R. Tringham and G.W. Dimbleby (eds.), Duckworths, London, pp. 193-206. (quoted from Barnicot et al., 1972b)
- Yoneyama, T., 1969. The life and society of the Iraqw. Kyoto University African Studies, 4: 77-114.