

# Lithium-Drifted Silicon Junction Detectors

Sakae NISHIU\*, Takashi NAKAKADO\*, Yasuyuki NAKAYAMA\*\*  
and Sakae SHIMIZU\*\*

(Shimizu Laboratory)

*Received August 27, 1964*

The authors have succeeded in preparing the Li-ion drifted silicon detector with favorable characteristics for electron detection. Details of the preparation procedure are described. Various characteristics of the detectors prepared are examined by uses of nuclear radiations including electrons, alpha particles and gamma rays. Especially, the detector response for incident electrons are studied using conversion electrons from some nucleids and mono-energetic electrons obtained by a beta-ray spectrometer at room and liquid-nitrogen temperatures. The p-i-n junction detectors prepared exhibit their extreme usefulness for measuring beta rays from very weak sources. It may be emphasized that in some aspects the use of the semiconductor detector of such a type for beta-ray spectroscopy seems to be advantageous compared with the usual magnetic spectrometer, although there remain yet some essential properties should be improved. For gamma-ray spectroscopy this detector also shows its usefulness when it is used at lower temperature, especially by its excellent energy selection for incident photons compared with the crystal scintillation detector. The radiation damage and spontaneous deterioration of the detector are also studied. As a cause responsible for the deterioration, the redistribution of lithium atoms in silicon with the lapse of time after the Li-ion drifting process is examined in some details. Some discussions on the measurements of nuclear radiations performed with the p-i-n junction detector prepared are also given, which may suggest the prospective improvement of this new radiation detector.

## I. INTRODUCTION

For many years since the early stage of study on radioactivity the interaction of nuclear particles and gamma rays with solids has been used for the detection of these radiations. The methods by scintillation crystals and photographic emulsion have been developed rapidly as the very powerful means to study the properties of nuclear radiations, especially since the Second World War, while, it had long been recognized that many advantages would be achieved if the direct measurement of the charge liberated by incident radiations in solids could be made.

It was first demonstrated by Van Heerden<sup>1)</sup> in 1945 that under certain condition, a crystal of silver chloride with a suitable potential difference across it would give a conduction pulse if an ionizing particle passed through the crystal. The solid counters such as using silver chloride crystal and other single

\* 西宇 栄, 中門 孝 (Also at Takarazuka Radiation Laboratory, Sumitomo Atomic Energy Industries, Ltd., Takarazuka)

\*\* 中山 康之, 清水 栄

crystal such as diamond and alkali halides, were investigated by Hofstadter<sup>27</sup> and many other workers in the following several years. However, these counters were found to have many disappointing features because trapping and recombination effects prevented the efficient charge collection. Large fluctuations in charge collection efficiency were often observed between different crystals and even between areas of the crystal. By this reason, such a crystal counter has been discarded as the useful measuring instrument for the nuclear radiations.

In 1949 McKay<sup>31</sup> investigated the use of a single crystal of very pure germanium, obtained by the zone-refining method, as a detector of charged particles. In this case the serious trapping and recombination troubles inhering in other crystal counters were found to be absent. By the use of p-n junction structure he achieved sufficiently high electric fields to collect the charge produced by incident particles without unfavorable noise. He thus demonstrated that an electrical pulse could be observed by the p-n junction of germanium when it was struck by an alpha particle, and then subsequently a p-n junction of pure silicon was found by him<sup>31</sup> to be also satisfactory for the alpha-particle detector even as an alpha-ray spectrometer.

In 1955 Simon<sup>61</sup> and in 1956 Mayer and Gossick<sup>61</sup> investigated the possibility of using Au-Ge surface barriers as alpha-particle detectors, and found that pulses were produced by alphas incident on the surface barrier. They also pointed out the useful performance of the surface barrier detector as a spectrometer. These studies of usefulness of p-n junctions and surface barriers as alpha-ray spectrometers excited many researches on the semiconductor particle detectors with considerably high energy resolutions for incident particles. Since about 1961 both types of these detectors using silicon as a base material have been very common ones for alpha and proton spectroscopy.

The depletion layer of these detectors responsible for the energy measurement of incident particles is generally much less than the range of incident electrons in it, because for an electron of even 100 keV a range in silicon is about 60  $\mu$ . To measure alphas, protons and electrons of which energies are much larger, the depletion thickness of the detector should be increased. For this purpose, Elliot<sup>71</sup> improved the silicon detector of p-n junction type by employing the Li-ion-drift technique developed by Pell<sup>81</sup>, and thereby increased the usefulness of these detector to include longer-range particles. The Li-drifted silicon junction detector promised us the possibility of beta-ray spectroscopy. There have been published many reports on the preparation and performance of the detector of this type. Most of these deal with the pulse-height *vs* particle energy relation as well as energy resolution for mono-energetic electrons using several conversion lines from some nucleids. However, on the practical application of the semiconductor detector to the measurement of continuous beta-ray spectra only few papers have so far been published<sup>9~11</sup>).

We have been working to manufacture Li-drifted silicon junction detectors with favorable characteristics for electrons. In this paper, the method of its preparation, detection performance, especially for mono-energetic electrons and beta rays, and some other features of interests so far been experienced with

our detectors are described. Some discussions are also given on the results obtained, which may suggest fruitful future development of the detector.

## II. PREPARATION OF LI-DRIFTED JUNCTIONS

As a base material, vacuum-float-zoned p-type silicon crystals of 90~3000  $\Omega$ -cm have been used. Commercially available ones are the cylindrical ingots of about 25 mm in diameter. These ingots have been cut, by a diamond cutting wheel, in round slices of thickness of 2~4 mm. Its life time greater than 100  $\mu$ sec may be favorable; silicon with larger values of it seems to have more possibility for the good detectors. Our procedure is then as follows.

Both surfaces of the slice are lapped by abrasive carborundum powder (#600) to get uniform thickness, and then again by abrasive alumina powders (#1200 and #2000). The lapped slice is cleaned by acetone, trichloroethylene, then again acetone and rinsed by deionized water in turn in an ultrasonic cleaning vessel. To get ohmic electrical contact to the surface of the slice the electroless gold plating is applied in an aqueous solution of potassium gold cyanide<sup>12)</sup>.

The gold on one surface of the slice is masked by an acid-resistant painting (picein wax in toluene), and then gold on the opposite surface and periphery is removed by aqua regia. The slice is rinsed by deionized water, and etched slightly by a so-called 5 : 1 solution (a mixture of five parts HNO<sub>3</sub> and one part HF). Immediately after the etching the slice is washed out by deionized water and the acid-resistant wax is removed by the ultrasonic cleaning method using acetone, trichloroethylene and then again acetone in turn.

A suspension of lithium in mineral oil\* is painted with a small glass rod on the silicon surface from which gold is removed. The silicon slice thus treated is then placed in the diffusion furnace. The mineral oil is at first driven off at 250°~300°C for about 10 min, and then the temperature is raised up to 400°~450°C for 1~3 min to diffuse lithium atoms into silicon base. This procedure provides also the ohmic contact of a gold-silicon alloy on the other surface. After this diffusion procedure the temperature is reduced to lower than 100°C and the sample is picked up from the furnace. For the diffusion depth a considerable difference between its calculated and measured values was found; the latter value was found generally larger than the calculated one. This may be due to the fact that the time for increasing and decreasing of temperature would not be negligible compared with relatively short duration for diffusion. For our purpose the diffusion depth needed not be controlled strictly. We chose the duration for diffusion to be rather shorter than the calculated value.

The slice after the diffusion procedure is immersed into ethanol to remove excess lithium remaining on the surface, and then washed again by trichloroethylene. Thereafter, the surface treated by lithium diffusion procedure is

\* Available from Lithium Corporation of America Inc., New York; 30% lithium, 69% mineral oil, and 1% oleic acid.

plated by nickel using the electroless plating method<sup>13)</sup>. From fabricated slices thus manufactured we obtained three kinds of slices of 10, 7.5 and 5 mm in diameter, which were used as the basic elements for our detectors. Both surfaces of such a diode are also masked by an acid-resistant wax and then only periphery is etched by the 5:1 solution for about several minutes. Thereafter, the wax is removed completely as described earlier.

The next step is the procedure of the Li-ion drift. However, prior to this procedure, quality of the diode obtained was examined by observing a current with a backward bias voltage of 200 V. The diode with the observed reverse current less than several  $\mu\text{A}$  seemed to endure the next procedure. When the current is larger than that expected, etching of the periphery of the diode should be made once again as described above. The selected diode is sandwiched by copper or nickel plates and immersed into the silicon-oil bath under applying a reverse voltage. The conditions of this Li-ion drifting were determined using nomographs prepared by Blankenship and Borkowski<sup>14)</sup>. In our work temperature of the bath was  $120^{\circ}\sim 150^{\circ}\text{C}$  and an applied reverse bias voltage was  $100\sim 350\text{ V}$ . As is shown by Pell<sup>8)</sup>, the compensation of p-type region is performed automatically and the compensated region (i-layer) grows with the elapse of drift time. As a thickness of the compensated region is proportional to a square root of drift time, it requires considerably long time to get thicker i-layer; e.g. with normal conditions about 20 hours for 2 mm thickness and about 50 hours for 3 mm thickness.

Since the dead layer is an essential factor when the p-i-n junction is used as a detector of nuclear particles, we have prepared two kinds of the junction detectors; one is such as its n-side (lithium diffused) being exposed to the nuclear radiations to be detected, while in the other its p-side (gold plated) being exposed to the radiations. In the former type the thickness of the dead layer could not be too thin owing to the surface density of lithium and its diffusion depth, but the best energy resolution for incident electrons could be achieved by this type of the detector. In the latter case the dead layer could be thinner when the lithium drifting was performed for longer duration. The i-layer happened often to reach the opposite surface by too much Li-ion drifting. such a diode exhibits so unfavorable rectifying action that can not be used as the detector. It is noted that with such diodes any improvement in their rectifying characteristics was never achieved by applying the forward-voltage ion drifting, on the contrary to the experiences reported by Mann and Janarek<sup>15)</sup>. The reliable way to make the dead layer thinner is that in the later stage of the drifting the diode is picked up once and again and then the thickness of the dead layer is examined by the use of alpha particles. Applying this procedure the thinnest dead layer we obtained was about  $10\mu$ .

### III. DETECTOR PERFORMANCE

Several samples of Li-ion drifted silicon junction detectors prepared by the procedure as described in the preceding chapter were used to examine their

various properties for incident nuclear radiations.

### III.1. Dependence of Leakage Current, Capacity and FWHM on Bias Voltage

With a detector (SGKL #731) the energy resolution, expressed by the full width at half maximum (FWHM), was measured for the K-conversion electrons from  $^{137}\text{Cs}$  (625 keV) as a function of the reverse bias voltage at room temperature. In the same time the capacitance and leakage current were also measured in both air and vacuum. The results obtained are shown in Fig. 1.

At room temperature there seems to be an optimum value of the detector bias. It was found that when bias voltages above the optimum value were applied, some samples showed rapid increase of noise, while some others showed less increase of noise. The slight dependence of capacitance on the applied bias, as shown in the figure, means some expansion of the depletion layer. This observed effect may be due to deterioration of the i-layer during the time after the preparation of the detector, as pointed out by Mayer<sup>16)</sup>. The charge collection efficiency with a bias voltage of 50 V was observed to be quite similar to that with a higher bias.

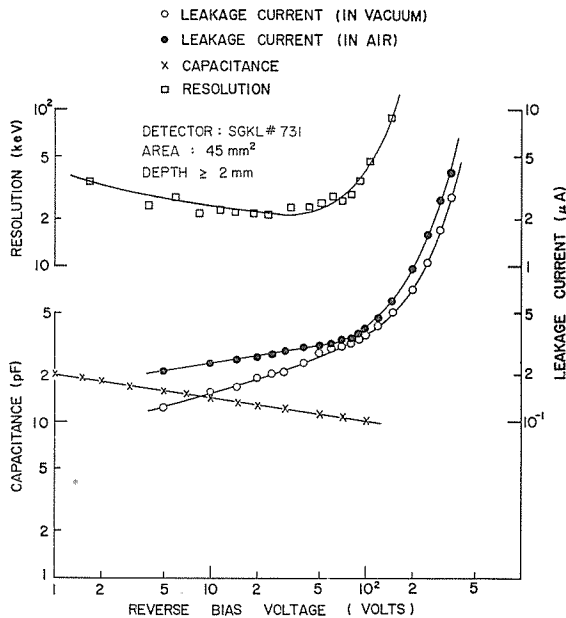

Fig. 1. Dependence of leakage current, capacity and energy resolution (FWHM) upon the bias voltage of a p-i-n silicon junction detector at room temperature. Energy resolutions were observed using the K-conversion electrons from  $^{137}\text{Cs}$  (625 keV).

### III.2. Response to Alpha Particles

The energy spectrum of alpha particles from  $^{212}\text{Pb}$  observed with a detector (SGKL #711) is shown in Fig. 2. As described in the preceding chapter, the thickness of the dead layer in p-side can be reduced as thin as desired, but it

is very troublesome to get a thickness less than several  $\mu$ , which is often requested for alpha-ray spectroscopy. Moreover, such an attempt often results in failure owing to the excess drifting. This may be due to the fact that a surface of the i-layer does proceed not always in parallel with the silicon surface, as described by Miller *et al.*<sup>17)</sup>. As a plan to cope with this difficulty there is a method devised by Blankenship and Borkowski<sup>14)</sup>, who diffused firstly phosphore into a silicon surface to make it a window for incident particles. This method, however, has a defect of making life-time of the free carriers very short by the procedure at rather high temperature.

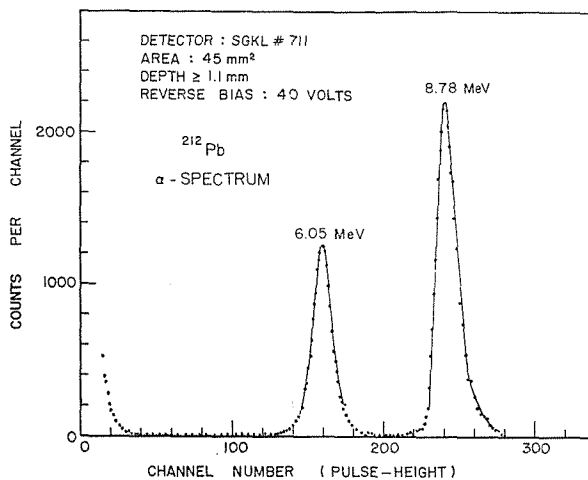

Fig. 2. Alpha particle spectrum from <sup>212</sup>Pb.

### III.3. Response to Electrons

Mounting our p-i-n detector at the detector position in the beta-ray spectro-

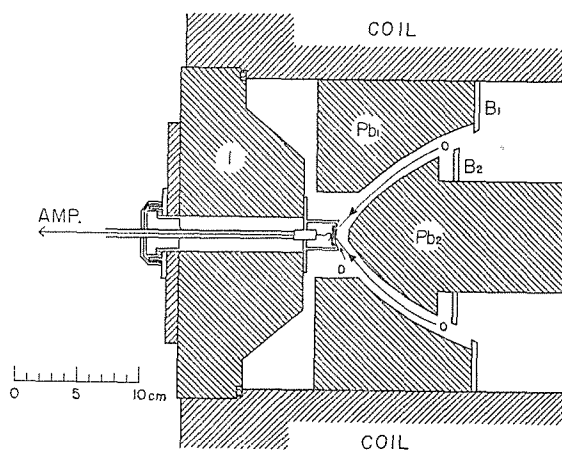

Fig. 3. Schematic diagram showing geometrical arrangement of the p-i-n silicon junction detector mounted in an intermediate image focusing spectrometer to measure mono-energetic electrons. Electron trajectories are shown by O. D - p-i-n silicon junction detector, I - polepiece, Pb<sub>1</sub> - lead shield, Pb<sub>2</sub> - central lead gamma-ray stop, B<sub>1</sub>, B<sub>2</sub> - lead baffles.

Lithium-Drifted Silicon Junction Detectors

meter of intermediate image focusing type, as shown schematically in Fig. 3, and using a  $^{32}\text{P}$  point source, the response to mono-energetic electrons was observed. The result of our observation is shown in Fig. 4. The spectrum for each mono-energetic electron line exhibits a sharp peak accompanied with a flat tail in lower energy side. Although the detector used had its depth of the sensitive region corresponding to the range of an electron of about 1.1 MeV, an evident peak was observed even with 1.7 MeV electrons. The relationship of pulse-height *vs* electron energy observed was quite linear in an energy region from 150 keV to 1700 keV, as shown in Fig. 5. A peak by 100 keV electrons could not be observed obviously owing to disturbing noise. This may be in

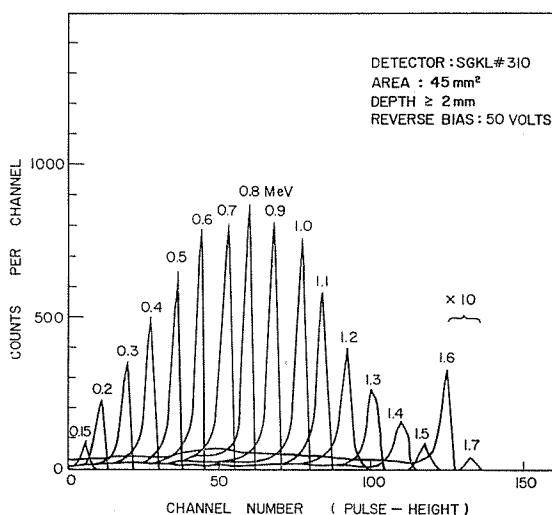

Fig. 4. Response of a p-i-n silicon junction detector to electrons in the energy range from 150 keV to 1700 keV.

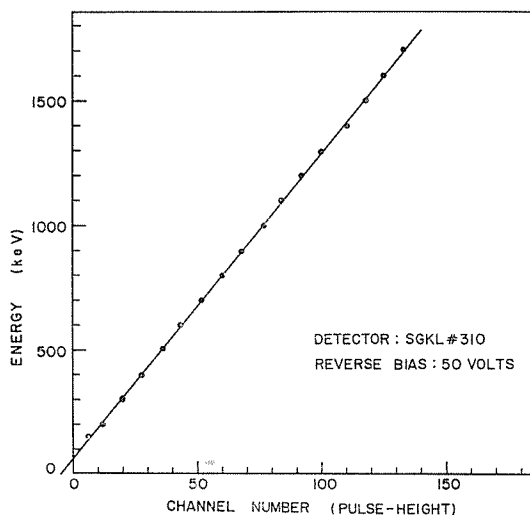

Fig. 5. Linearity check of a p-i-n silicon junction detector for mono-energetic electrons at room temperature.

part due to the oblique incidence of electrons to the detector as shown in Fig. 3. The values of the peak-to-total ratio, obtained from the result shown in Fig. 4, are listed in Table 1.

Table 1. Peak-to-total ratios for mono-energetic electrons with a p-i-n silicon junction detector (SGKL #310, diameter : 7.5 mm, depth : 2 mm, reverse bias : 50 V).

Electron energy (keV)	Peak-to-total ratio	Electron energy (keV)	Peak-to-total ratio
1700	0.15	1000	0.60
1600	0.21	900	0.67
1500	0.27	800	0.71
1400	0.30	700	0.71
1300	0.37	600	0.73
1200	0.46	500	0.76
1100	0.55	400	0.78

Several internal conversion electrons from  $^{207}\text{Bi}$ ,  $^{137}\text{Cs}$  and  $^{113}\text{Sn}$  have been also observed by our detector (SGKL #731). Each radiation source was prepared by evaporating a small amount of radioactive solution into dryness on a rubber hydrochloride foil. The area of the source was 5~10 mm in diameter. The source could be placed without a collimator at about only 20 mm from the surface of the detector to get sufficiently large effective solid angle for incident electrons. The "luminosity" of this detecting arrangement with a semiconductor detector is, therefore, much larger than that with the beta-ray spectrometer of any type. Our observations are shown in Figs. 6~9.

Figure 6 shows the internal conversion lines and X rays from  $^{207}\text{Bi}$  observed at room temperature. The observed spectra of the internal conversion electrons

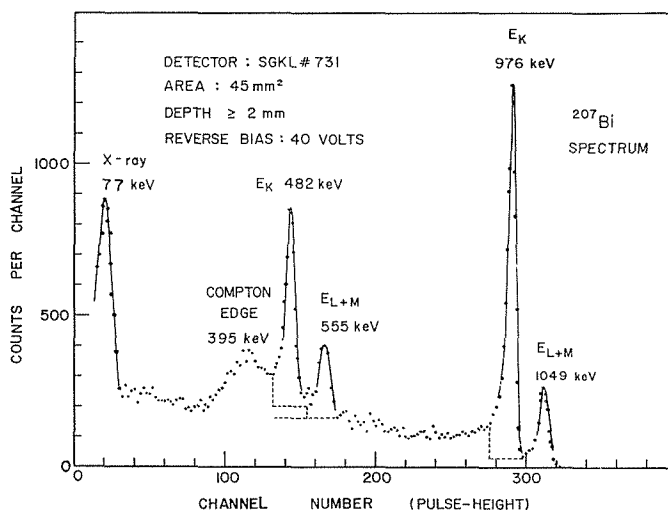

Fig. 6. Pulse-height spectrum of conversion electrons of  $^{207}\text{Pb}$  observed with a p-i-n silicon junction detector at room temperature. Electrons were injected into the n-side of the detector.



Lithium-Drifted Silicon Junction Detectors

from  $^{137}\text{Cs}$  at room temperature and liquid-nitrogen temperature (77°K) are shown in Figs. 7 and 8, respectively. In these spectra the values of FWHM of the K-conversion line (625 keV) achieved with our detector are 19.5 keV at room temperature and 14.6 keV at liquid-nitrogen temperature. The vacuum chamber used for cooling the detector is shown schematically in Fig. 10. Our detector can separate K- and (L+M)-lines of  $^{113}\text{In}$  even at room temperature, as shown in Fig. 9.

Using the observed spectrum of internal conversion electrons of  $^{207}\text{Pb}$  shown

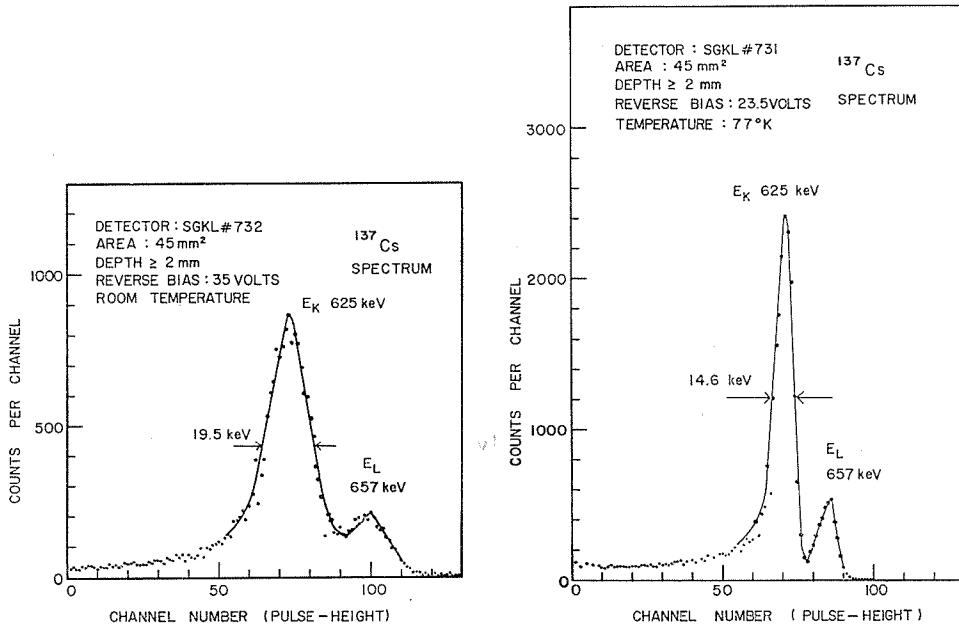

Fig. 7. Pulse-height spectrum of conversion electrons of  $^{137}\text{Ba}$  observed with a p-i-n silicon junction detector at room temperature.

Fig. 8. Pulse-height spectrum of conversion electrons of  $^{137}\text{Ba}$  observed with a p-i-n silicon junction detector at 77°K.

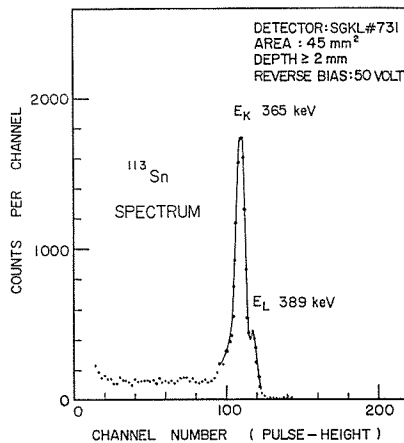

Fig. 9. Pulse-height spectrum of conversion electrons of  $^{113}\text{In}$  observed with a p-i-n silicon junction detector at room temperature.

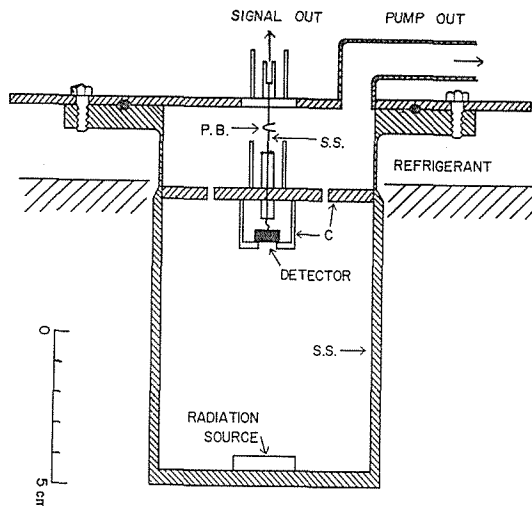

Fig. 10. A vacuum chamber for cooling the detector. S.S. - stainless steel, P.B. - phosphor bronze, C - copper.

in Fig. 6 and values of peak-to-total ratios for electrons given in Table 1, we have attempted to estimate the values of conversion ratio  $\alpha_K/(\alpha_L+\alpha_M)$  for 570 keV E2 and 1064 keV M4 transitions. In the present case it was assumed that the values of peak-to-total ratio obtained by a detector, SGKL #310, given in Table 1 can be applied to the photopeaks observed with  $^{207}\text{Bi}$  by the other detector, SGKL #731, since the constructions of these both detectors were nearly similar excepting some difference between detecting arrangements for incident electrons.

Let  $N$  be the total number of K-conversion electrons striking against the detector surface,  $\eta$  the intrinsic detecting efficiency,  $R$  the peak-to-total ratio and  $P$  the total number of counts for the peak concerned, and  $N'$ ,  $\eta'$ ,  $R'$ , and  $P'$  the corresponding values to (L+M)-conversion electrons, then  $P$  and  $P'$  are given by

$$P = \eta RN, \quad P' = \eta' R' N'. \quad (1)$$

A conversion ratio  $\alpha_K/(\alpha_L+\alpha_M)$  can be expressed by

$$\alpha_K/(\alpha_L+\alpha_M) = N/N' = \frac{\eta' R'}{\eta R} \frac{P}{P'}. \quad (2)$$

The values of  $P$  and  $P'$  were obtained from the observed spectrum shown in Fig. 6, while  $R$  and  $R'$  were obtained using the data given in Table 1.

The estimation of  $\eta$  as a function of the energy of incident electrons is an important and interesting problem. It can be performed by an experiment using a beta-ray spectrometer with an appropriate source. The counting rate by a detector concerned is first measured and then this detector is replaced by a G-M counter with a very thin window to count the electrons with given energy under the identical experimental conditions. If the intrinsic detecting efficiency of this G-M counter can be considered to be 100% for incident

electrons with an given energy, the ratio of counting rate of both detectors would provide the value  $\eta$  of the semiconductor detector to be examined. In the present work, we pursued such a procedure using an intermediate image focusing beta-ray spectrometer and some beta-ray emitters and could estimate the necessary values of  $\eta_1$ .\* The numerical values of the factors in Eq. (2) thus obtained are as followings :

$$\begin{aligned} \eta &= 0.63, R=0.76 \text{ for K-conversion electrons } (E_K=482 \text{ keV}) ; \\ \eta' &= 0.66, R=0.75 \text{ for (L+M)-conversion electrons } (E_{L+M}=555 \text{ keV}) ; \\ \eta &= 0.83, R=0.65 \text{ for K-conversion electrons } (E_K=976 \text{ keV}) ; \\ \eta' &= 0.83, R=0.61 \text{ for (L+M)-conversion electrons } (E_{L+M}=1049 \text{ keV}). \end{aligned}$$

The rough values of the conversion ratio,  $\alpha_K/(\alpha_L+\alpha_M)$ , thus estimated by our work are listed in Table 2 together with those reported by other workers.

Table 2. Conversion ratios,  $\alpha_K/(\alpha_M+\alpha_L)$ , for the 570 keV E2 and 1064 keV M4 transitions in  $^{207}\text{Pb}$ .

Transition energy (keV)	Conversion line (keV)	$\alpha_K/(\alpha_M+\alpha_L)$			
		Alburger*	Wapstra**	Ricci+	Present work
570	482 (K)	—	3.0	3.3	2.8
	555 (L+M)				
1064	976 (K)	3.00±0.25	3.4	3.8	3.6
	1049 (L+M)				

\* By a double-focusing spectrometer ; D. E. Alburger, *Phys. Rev.*, **92**, 1257 (1953).

\*\* By an intermediate image focusing spectrometer ; A. H. Wapstra, *Arkiv Fysik*, **7**, 279 (1954).

+ By a scintillation spectrometer (anthracene crystal) ; R. A. Ricci, *Physica*, **23**, 693 (1957).

We have measured some continuous beta-ray spectra from disintegrations of  $^{204}\text{Tl}$ ,  $^{137}\text{Cs}$ ,  $^{22}\text{Na}$  and  $^{32}\text{P}$ . In Figs. 11~14 are presented these spectra and the corresponding Fermi-plots. In the Fermi-plot of beta-rays from  $^{204}\text{Tl}$  a bend was observed in higher energy region, as shown in Fig. 11, but it could not be understood. The beta-ray spectrum of  $^{137}\text{Cs}$  and the corresponding Fermi-plot are shown in Fig. 12. In this case the linear part of the Fermi-plot is extending to the lower energy region. The Fermi-plot of the beta-ray spectrum of  $^{22}\text{Na}$  was obtained by subtracting the gamma-ray contribution from the observed spectrum. In the pulse-height distribution of gamma-ray photons, mainly due to the annihilation radiation, an evident peak of the Compton edge appears at about 341 keV, as shown in Fig. 13. The maximum energies of the observed spectra measured from the corresponding Fermi-plots, given in Figs. 11~13, are in good agreement with the values so far reported by other workers. As shown in Fig. 14, the observed Fermi-plot of the beta-rays of  $^{32}\text{P}$  is not linear but slightly concaving. Since the depth (2 mm) of the detector

\* The more accurate experimental determination of the intrinsic detecting efficiency of the p-i-n junction detector for incident electrons is now in progress. A report on the work will be published in the near future.

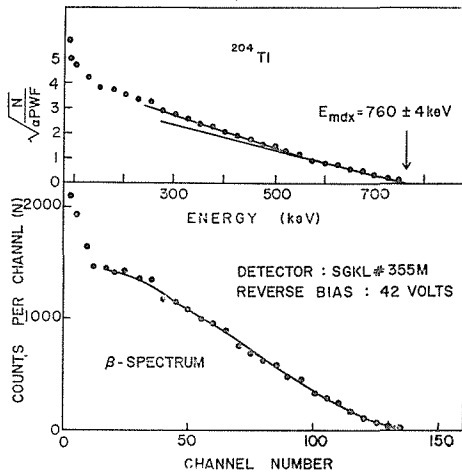

Fig. 11. Beta-ray spectrum of  $^{204}\text{Tl}$  and its Fermi plot observed with a p-i-n silicon junction detector at room temperature.

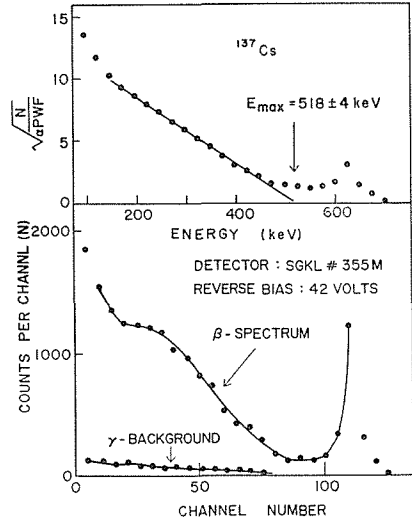

Fig. 12. Beta-ray spectrum of  $^{137}\text{Cs}$  and its Fermi plot observed with a p-i-n silicon junction detector at room temperature.

used was less than the range of electrons of 1.7 MeV in it, we tried to inject the beta rays obliquely into the detector, however, observed spectrum was similar to that obtained with the normal incidence of the beta rays, excepting

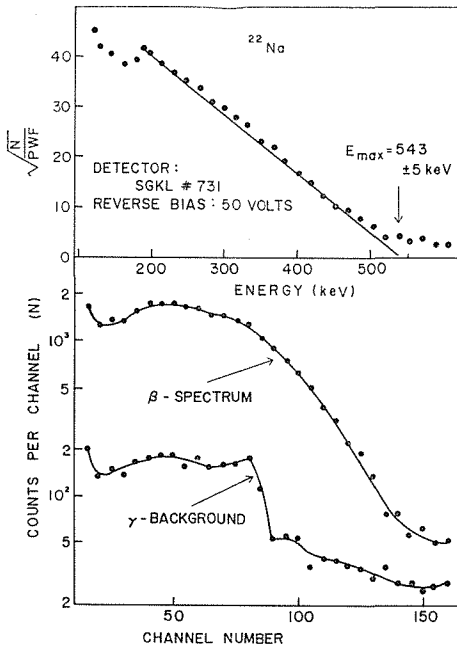

Fig. 13. Beta-ray spectrum of  $^{22}\text{Na}$  and its Fermi plot observed with a p-i-n silicon junction detector at room temperature.

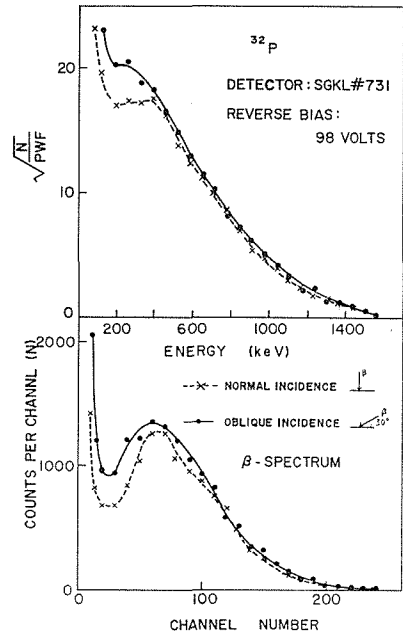

Fig. 14. Beta-ray spectrum of  $^{32}\text{P}$  and its Fermi plot observed with a p-i-n silicon junction detector at room temperature.

the shape in the lower energy region, as shown in Fig. 14. This may be due to the fact that the behavior of electrons in silicon is quite different from that of alpha particles.

Reflecting on our experiences in using the p-i-n silicon junction detectors we prepared, it may be emphasized that the use of the detector of such a type for beta-ray spectroscopy seems to be advantageous if we will be able to prepare the detectors with more improved characteristics. One of the merits in using it for beta-ray spectroscopy is much larger geometrical luminosity of this method compared with that in usual magnetic beta-ray spectrometers.

#### III.4. Response to Gamma Rays

When the thickness of the i-layer of the p-i-n junction detector is several mm or more, the photoelectric absorption of lower energy gamma- or X-ray photons in this layer is considerably large and evident peaks in the observed spectra of incident photons would be expected. In this case the effect of the dead layer for the incident gamma or X rays is very small as being negligible. A merit in observing the gamma-ray spectra with such a p-i-n junction detector is a smaller value of the FWHM to the photopeak compared with that in the NaI (TI) scintillation spectrum.

The gamma-ray spectrum from  $^{57}\text{Co}$  observed at 77°K is shown in Fig. 15. At this temperature the detector could be regarded as an insulator. A leakage current observed was only about one percent or less of the values given in Fig. 1. The FWHM of the photopeak due to the 122 keV gamma ray is 7 keV, while the intrinsic FWHM of the detector is 5.6 keV, as shown in Fig. 15.

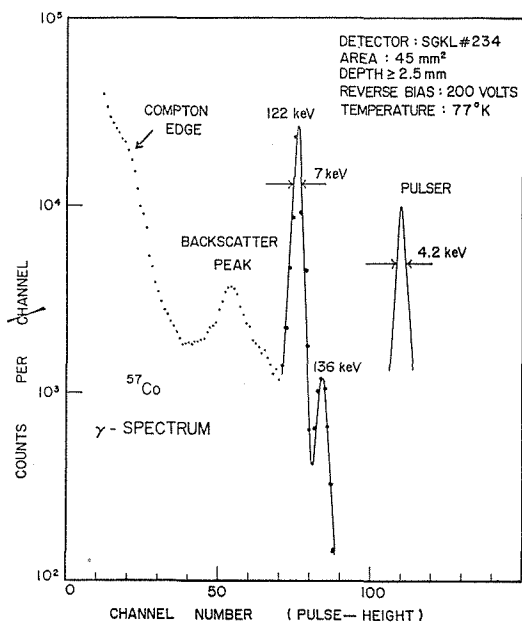

Fig. 15. Gamma-ray spectrum from  $^{57}\text{Co}$  observed with a p-i-n silicon junction detector at 77°K.

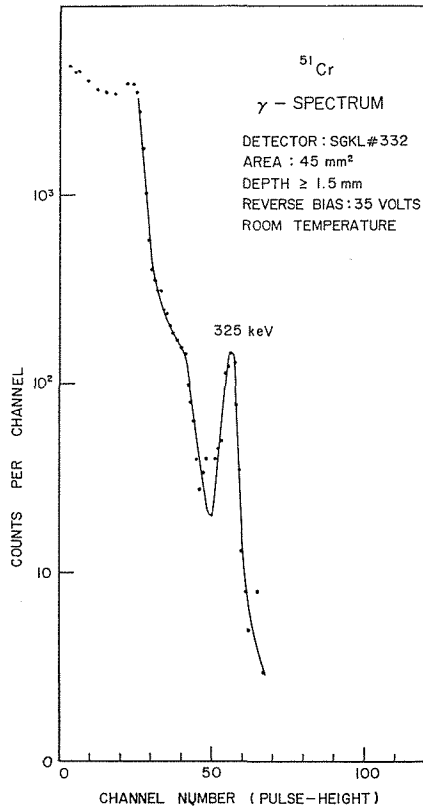

Fig. 16. Gamma-ray spectrum from  $^{51}\text{Cr}$  observed with a p-i-n silicon junction detector at room temperature.

These FWHM values were observed using a slightly modified low noise amplifier, of which original model was designed by Fairstein<sup>18)</sup>. This amplifier has been used throughout the present work.

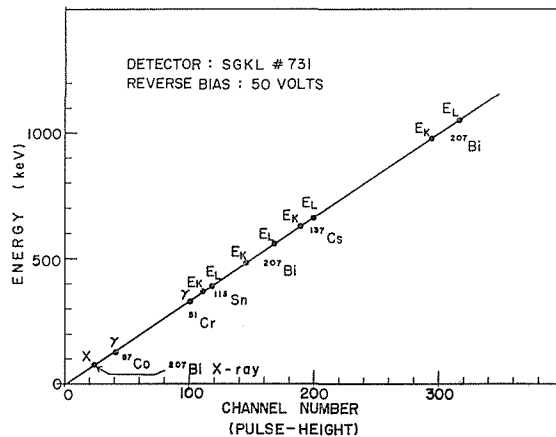

Fig. 17. Pulse-height response of a p-i-n silicon junction detector to internal conversion electrons, gamma rays and X rays at room temperature.

In Fig. 16 the gamma-ray spectrum from  $^{51}\text{Cr}$  observed at room temperature is shown, where the Compton edge appears predominantly.

The relationship of pulse-height *vs* energy of incident radiations observed with a detector at room temperature is shown in Fig. 17. As is shown in the figure, the peak pulse-height of the detector to energy of incident radiations is quite linear.

#### IV. RADIATION DAMAGE AND SPONTANEOUS DETERIORATION

It has been known that the semiconductors of many types are deteriorated gradually during its long-time use by irradiation of nuclear radiations, which induces permanent damage in the internal structure of the detector materials. Some experimental results of the deterioration of the usual silicon detectors of p-n junction and surface-barrier types by the effects of electrons, protons, fast neutrons, alpha particles and fission fragments have recently been published by several workers<sup>19-24)</sup>. For the p-i-n silicon detector the radiation damage effects with protons, alpha particles and fast neutrons have recently been studied by Mann and Yntema<sup>25)</sup> and with  $^{60}\text{Co}$  gamma rays by Coleman and Rodgers<sup>26)</sup>. It may be generally anticipated that the total doses of these radiations at which significant damage would be observed are largest with fission fragments and smallest with electrons. However, to our literature search no systematic study on the radiation damage of the p-i-n silicon detector by electrons has so far been published.

By using a weak electron beam with an energy of about 1.3~1.7 MeV produced by a Van de Graaff accelerator, we have attempted to observe the radiation damage effects in a p-i-n silicon detector we prepared. As a result of radiation damage the gradual increase of the FWHM of a peak in the pulse-height spectrum was first observed without any change of the leakage current, and after that this current began to increase.

Some workers have observed the spontaneous deterioration in the p-i-n junction detector when it was stored at room temperature without applying a reverse bias voltage<sup>7,16,27)</sup>, while some others have reported that no appreciable effect was observed after several months' storage at room temperature<sup>14,28)</sup>. In Fig. 18 are shown our observations of the deterioration of the detector response to mono-energetic electrons for ten months after its preparation. The electrons of 1.5 MeV used were produced by the use of a beta-ray spectrometer and the initial thickness of the i-layer of the detector was nearly equal to the range of a electron with an energy of 1.1 MeV. As it is seen from Fig. 18, the FWHM value and peak-to-total ratio deteriorated gradually with the lapse of time. In this case no increase of the leakage current has been observed, and also the total FWHM of the whole system, including the detector and amplifier, checked with a pulse generator has not exceeded 15 keV.

Using alpha particles from  $^{210}\text{Po}$  and  $^{212}\text{Pb}$  we estimated the thickness of the p-side dead layer and found its increase for ten months being about  $20\mu$ . Since the radiation damage with alpha particles has been known to be

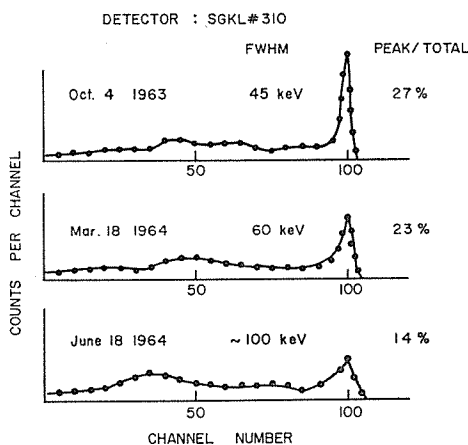

Fig. 18. Deterioration of response of a p-i-n silicon junction detector to mono-energetic electrons of 1500 keV at room temperature with the lapse of time. During storage of the detector at room temperature no reverse bias voltage was applied.

appreciable when the total dose of alpha particles is larger than  $10^8/\text{cm}^2$ <sup>26)</sup>, and in the present case the lowering of the charge collecting efficiency was not observed as generally observed with the radiation damage<sup>25,26)</sup>, the observed deterioration of the detector seemed to be not due to incident electrons ( $<10^7/\text{cm}^2$ ) but to other causes. The redistribution of lithium atoms in the detector was considered as a cause responsible for observed increase of the dead layer. The distribution of lithium atoms immediately after the Li-ion drifting process is shown by a bold line in Fig. 19. Assuming this distribution at both ends of the i-layer being vertical, and let B-point in the figure be an original point of abscissa, then the one-dimensional equation for the distribution of lithium atoms in a vicinity of B-point can be expressed by<sup>29)</sup> :

$$C(x, t) = \frac{C_0}{2} \left[ 1 - \text{erf} \frac{x}{2(D_{err} t)^{1/2}} \right], \quad (3)$$

$$D_{err} = \alpha D, \quad (4)$$

where

$C(x, t)$  = concentration of lithium atoms at  $x$  when  $t$  after the Li-ion drifting,

$C_0$  = concentration of boron atoms =  $1.5 \times 10^{14}$  atoms/cm<sup>3</sup>,

$D_{err}$  = effective diffusion coefficient of lithium atoms at room temperature,

$D$  = true diffusion coefficient of lithium atoms at room temperature =  $3 \times 10^{-14}$  cm<sup>2</sup>/sec<sup>30)</sup>.

The diffusion coefficient at room temperature is reduced by a factor  $\alpha$  owing to the effects of Li-B ion pairings and Li-O interactions<sup>30,31)</sup>. Taking into account of the fraction of lithium atoms paired with boron atoms being about 20% and oxygen atoms being  $10^{15}$  atoms/cm<sup>3</sup> in the silicon we used,  $\alpha$  in the p-side dead layer can be given approximately as  $\alpha=0.4$ . Using this value and the relations (3) and (4) we can estimate the possible increase of the p-side dead layer as about  $23 \mu$ , which is in agreement with our observed value.



### Lithium-Drifted Silicon Junction Detectors

However, from this discussion it can be ascertained that the dead layer proceeds in parallel with its initial boundary. The observed increase of the FWHM can not be explained only by the increase of the dead layer of about  $20\ \mu$ , because the energy spread of the 1500 keV electrons after the penetration through a silicon layer with this thickness would be expected to be only 1.5 keV<sup>22)</sup>.

An increase of the n-side dead layer due to the redistribution of lithium atoms has also been calculated; it is shown by AD in Fig. 19. Since especially in the n-side the effective diffusion coefficient of lithium atoms changes considerably by the effect of Li-B and Li-O interactions, the value of  $50\ \mu$  is an approximately calculated value with an accuracy of  $\pm 20\%$ . The distribution of lithium ions after the redistribution is given by a broken bold line in Fig. 19.

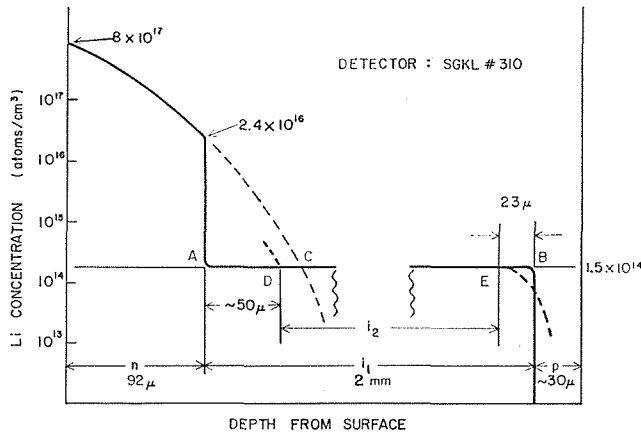

Fig. 19. Calculated distribution of lithium atoms in a p-i-n silicon junction detector. A bold line shows an initial distribution (i-layer being shown by  $i_1$ ), while a broken bold line shows the distribution ten months after the Li-ion drifting process (i-layer being shown by  $i_2$ ).

The detector (SGKL #310) which gave the results shown in Fig. 18 was treated again by the drifting process of sufficient duration after whole series of experiments, but the deterioration of the spectrum could not be improved. On this respect our experience was not in accordance with that reported by Elliot<sup>27)</sup>.

As a conclusion it may be asserted that the increase of the p-side dead layer and decrease of the i-layer is at least a cause responsible for the decrease of the peak-to-total ratio observed as shown in Fig. 18. The increase of the FWHM can not, however, be explained satisfactorily by only this cause. In the detector any other essential change seems to have happened. To prevent the redistribution of lithium ions the storage of the detector at cooled place with applying a small reverse bias voltage seems to be effective, but, if any technique of replacing the dead layer at both p- and n-sides by other materials<sup>28)</sup> will be realized successfully the trouble concerned would be overcome.

## V. CONCLUSION

We have succeeded in preparing the Li-ion drifted silicon detector with favorable characteristics. It has some advantageous properties for beta-ray spectroscopy. Although the energy resolution of such a detector is one or two orders of magnitude lower than that of the usual beta-ray spectrometer, the luminosity of the measuring arrangement with the detector is much larger than that achieved by the latter. This merit as well as the low inherent background compared with that M-G counters or scintillation detectors make them extremely useful for measuring beta rays from very weak sources. From a theoretical point of view it is better to inject electrons into the p-side, but according to our work it is not always necessary conditions for a detector with a thickness less than 4 mm. The improvement of the detector to extend its sensitivity to lower or higher energy regions for incident electrons should be required.

For gamma-ray spectroscopy, tolerating low detecting efficiency, the p-i-n junction detector used at lower temperature exhibits much better energy resolution than that with the crystal scintillation detector.

After ten months' storage of the detector at room temperature the deterioration of pulse-height response to incident mono-energetic electrons has been observed. As one of the causes for this spontaneous deterioration with the lapse of time, we have considered the redistribution of lithium atoms in the detector and found a fairly good agreement between experimental and calculated values. However, there would be any other cause responsible for this phenomenon. On the radiation damage and spontaneous deterioration of the p-i-n junction detector further study should be necessary.

## ACKNOWLEDGEMENTS

The authors would like to thank Hideaki Nakamori and Junichiro Murayama for their cooperation with the present work. Two of the authors (S. N. and T. N.) are also very grateful to Dr. K. Fujimura and Mr. T. Naito, Director and Associate Director of their Laboratory, for their kind encouragement and support.

## REFERENCES

- (1) P. J. Van Heerden, Dissertation, Utrecht, 1945.
- (2) R. Hofstadter, *Nucleonics*, 4, No. 4, 2 and No. 5, 29 (1949).
- (3) K. G. McKay, *Phys. Rev.*, 76, 1537 (1949); 84, 829 (1951).
- (4) K. G. McKay and K. B. McAfee, *Phys. Rev.*, 91, 1079 (1953).
- (5) E. Simon, Thesis, Purdue University, 1955.
- (6) J. W. Mayer and K. B. Gossick, *Rev. Sci. Instr.*, 27, 407 (1956).
- (7) J. H. Elliot, *Bull. Amer. Phys. Soc.*, Ser. II, 5, 501 (1960); *Nucl. Instr. & Meth.*, 12, 60 (1961).
- (8) E. M. Pell, *J. Appl. Phys.*, 31, 291 (1960).
- (9) H. Bosch, F. Krmpotic and A. Plastino, *Nucl. Instr. & Meth.*, 23, 79 (1963).
- (10) J. Chin, A. T. Hirshfeld and D. D. Hoppes, *Rev. Sci. Instr.*, 34, 1258 (1963).

### Lithium-Drifted Silicon Junction Detectors

- (11) E. Sakai, Japan Atomic Energy Research Institute, *JAERI-Memo*, No. 1464, Nov. 1963.
- (12) H. M. Mann and F. J. Janarek, *Rev. Sci. Instr.*, **33**, 557 (1962).
- (13) H. V. Sullivan and R. M. Warner, Jr., "Transistor Technology", Vol. III. ed. F. J. Biondi, D. Van Nostrand Co. Inc., Princeton, 1958, p. 173.
- (14) J. L. Blankenship and C. J. Borkowski, *I.R.E. Trans., Nucl. Sci.*, NS-9, No. 3, 181 (1962).
- (15) H. M. Mann and F. J. Janarek, *Nucl. Instr. & Meth.*, **17**, 71 (1962).
- (16) J. W. Mayer, *J. Appl. Phys.*, **33**, 2894 (1962).
- (17) G. L. Miller, B. D. Pate and S. Wagner, *I.E.E.E. Trans., Nucl. Sci.*, NS-10, No. 1, 220 (1963).
- (18) Oka Ridge National Laboratory and Office of Technical Information Extension, AEC, TID-6119, Aug. 1960.
- (19) R. W. Klingensmith, *I.R.E. Trans., Nucl. Sci.*, NS-8, No. 1, 112 (1960).
- (20) G. L. Kramer, *I.R.E. Trans., Nucl. Sci.*, NS-9, No. 3, 124 (1962).
- (21) G. Dearnaley, *I.E.E.E. Trans., Nucl. Sci.*, NS-10, No. 1, 106 (1963).
- (22) H. C. Britt and G. C. Benson, *Rev. Sci. Instr.*, **35**, 842 (1964).
- (23) G. G. George and D. M. Gunnensen, *Nucl. Instr. & Meth.*, **25**, 253 (1964).
- (24) G. Dearnaley, *Nucleonics*, **22**, No. 7, 78 (1964).
- (25) H. M. Mann and J. L. Yntema, *I.E.E.E. Trans., Nucl. Sci.*, NS-11, No. 3, 201 (1964).
- (26) J. A. Coleman and J. W. Rodgers, *I.E.E.E. Trans., Nucl. Sci.*, NS-11, No. 3, 213 (1964).
- (27) P. E. Gibbons, *Nucl. Instr. & Meth.*, **16**, 284 (1962).
- (28) G. Dearnaley, *Nucl. Instr. & Meth.*, **25**, 237 (1964).
- (29) W. Jost, "Diffusion in Solids, Liquids, Gases", Academic Press Inc., New York, 1960, pp. 20, 24, and 62.
- (30) E. M. Pell, *Phys. Rev.*, **119**, 1222 (1960).
- (31) H. Reiss, C. S. Fuller and F. J. Morin, *Bell Syst. Tech. J.*, **35**, 535 (1956).
- (32) W. Paul and H. Steinwedel, "Beta- and Gamma-Ray Spectroscopy", ed. K. Siegbahn, North-Holland Publishing Co., Amsterdam, 1955, p. 12.