

Comparison of Stopping Powers of Al, Ni, Cu, Rh, Ag, Pt and Au for Protons and Deuterons of Exactly the Same Velocity

Ryutaro ISHIWARI*, Naoko SHIOMI*, Shigeko SHIRAI*,
Tokiko OHATA** and Yoshiaki UEMURA***

Received October 26, 1971

Stopping powers of Al, Ni, Cu, Rh, Ag, Pt and Au for protons and deuterons of exactly the same velocity, of which the approximate energies are 7.2 MeV and 14.4 MeV, have been measured and compared to each other. The stopping powers for protons obtained in the present experiment have been found to be lower than the experimental results of Andersen *et al.* by 1 to 2.5 percent. It has been found that the stopping power for deuterons is significantly higher than that for protons of exactly the same velocity. The deviations are from 1 to 2.5 percent.

I. INTRODUCTION

In recent years there has been a growing interest in the stopping power data of various kinds of materials for heavy charged particles such as protons and deuterons. Experimental nuclear physicists need very accurate data for planning the experimental set up and for evaluating the results obtained. From the theoretical point of view, too, accurate stopping power data have been of continuous interest in connection with the determination of the basic parameters of the Bethe theory of stopping power, *i.e.* the mean excitation potential and the so-called shell corrections.

According to the Bethe theory,¹⁾ the stopping powers of a material for two different kinds of particles with equal charge and equal velocity are expected to be exactly the same. The most familiar example of such a pair of particles is protons and deuterons. The experimental verification of this prediction of the theory had been very poor. Several experiments²⁻⁴⁾ were published around 1948, but the accuracy of these experiments is presumed to be poorer than 10 percent. Recently, extensive stopping power measurements for protons and deuterons of wide variety of materials have been performed by Andersen *et al.*⁵⁻⁸⁾ in the energy range from 5 to 12 MeV with the stated error of 0.3 percent. They have presented their results in the form of Bichsel's X-variables⁹⁾ as functions of reduced energy $E \cdot M_p / M$, where E is the particle energy, M is the particle mass

* 石割隆太郎, 塩見 直子, 白井 重子: Department of Physics, Faculty of Science, Nara Women's University.

** 大島トキ子: Department of Physics, Faculty of Science, Nara Women's University, now at School of Liberal Arts and Science, Kyoto University.

*** 植村 吉明: Keage Laboratory of Nuclear Science, Institute for Chemical Research, Kyoto University.

and M_p is the proton mass respectively. That is, the data for deuterons were regarded as data for protons which have the same velocity as deuterons. They concluded that in the overlapping energy region around 5 MeV the deuteron and proton points fall together within the stated error. As far as their published figures are concerned, however, in cases of several elements, e.g. Al, Fe, Co, Zn, Ag and Pt, it seems for us that there exists a systematic trend that the proton points fall slightly lower than the deuteron points in the overlapping region.

Since this prediction is the most basic feature of the Bethe theory, it is felt enough worthy to confirm experimentally the prediction of the theory with different experimental techniques of sufficient accuracy apart from the effort to evaluate the basic parameters of the theory.

In a previous paper,¹⁰⁾ the energy losses of protons and deuterons of exactly the same velocity, of which the approximate energies were 7.2 and 14.4 MeV, have been compared in aluminium using a broad range magnetic spectrograph as a detector. It has been concluded that the energy losses were equal to each other to within 0.5 percent.

In the present study, the energy losses of 7.2 MeV protons and 14.4 MeV deuterons which have exactly the same velocity have been measured in Al, Ni, Cu, Rh, Ag, Pt and Au and compared to each other by using a silicon detector and associated counting equipments.

II. EXPERIMENTAL PROCEDURE

1. Experimental set up

In the present experiment, protons and deuterons accelerated by the Kyoto University Cyclotron were used.

The experimental set up is shown in Fig. 1. The method to analyze the beam with the analyzing magnet and to mount the absorber foil is the same as described in the previous experiment.¹⁰⁾ In the present study, to increase the efficiency of the particle detection the broad range magnetic spectrograph has been replaced by a silicon detector and associated electronic equipments.

The accelerated particles were focused with a pair of quadrupole magnets on the object slit S_1 of the sector type analyzing magnet. Then the beam with momentum spread of 0.1 percent was transmitted through the analyzing magnet and admitted into the reaction chamber through the slit S_2 which is 1 mm by 1 mm square. The beam was then scattered by a gold foil of 1.691 mg/cm² placed at the centre of the reaction chamber. The absorption measurement was made at an angle of 15 degrees with respect to the incident beam direction. The reason for using the scattered beam was to control the beam intensity. As is shown in Fig. 1, the sample foil was fitted on one of the sector windows of the absorber wheel of which the other sector window was left empty. The wheel was rotated at 24 r.p.m. during the measurement. Thus, scattered beam with and without the absorber passed alternatively through the wheel windows and were detected by the silicon detector. In this way, the pulse heights of the particles with and without the absorber were recorded simultaneously in one

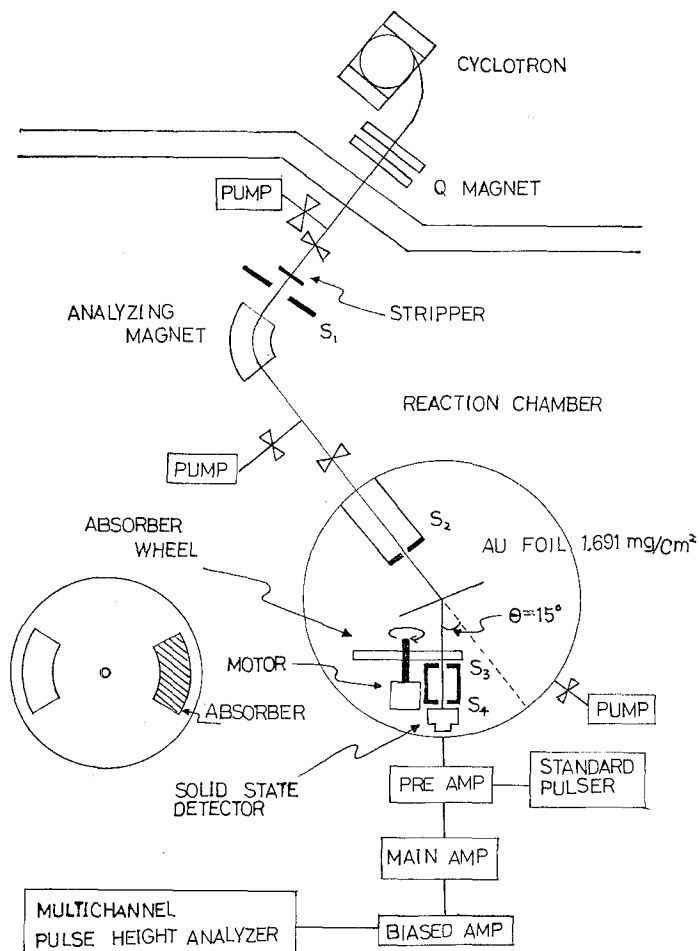

Fig. 1. The experimental set up for the energy loss measurement of the particles from the cyclotron by using a silicon detector.

exposure. By rotating the sample foil, the beam passes across the area of the foil so that the effect of local nonuniformity of the foil thickness was minimized.

The double slit system S_3 and S_4 , which have circular aperture of 1.5 mm and 2.0 mm in diameter respectively and were placed 80 mm apart, was placed between the absorber wheel and the detector to limit the direction of the beam incident to the detector. The distance from the scattering centre to the absorber was 52 mm and that of S_3 was 60 mm.

A surface barrier type silicon detector with 1000 microns depletion depth supplied by ORTEC was used. Pulses from the detector were amplified with a low noise amplifier and the interesting portion of the pulse height spectrum was expanded with a biased amplifier and fed into a Victoreen 400 channel pulse height analyzer.

The energies of the particles were absolutely determined by the analyzing magnet. The analyzing magnet was calibrated by ThC' alpha particles from a

Th(C+C') source. Ritz's energy value¹¹⁾ was used in the calibration. The magnetic field of the analyzing magnet was stabilized by a current stabilizer and was measured by the method of nuclear magnetic resonance. The magnetic field was set at a constant value before each exposure and checked immediately after each exposure. During the time of exposure from 10 to 15 minutes, the magnetic field was kept constant better than one part in 10^4 . The energies of the particles scattered at an angle of 15 degrees and incident to the absorber foil were calculated by using relativistic scattering kinematics with exact mass values and the absorption in the thin gold scatterer was calculated by using Andersen's stopping power data.⁶⁾ The gold scatterer was mounted in such a way that the normal to the scatterer was at an angle of 7.5 degrees (one half the scattering angle) with respect to the incident beam direction in the scattering plane.

2. Setting of magnetic fields

In general, the stopping power measurement requires the determination of the energy loss in a foil of finite thickness and of the foil thickness as well as that of the incident energy. Then, the energy loss divided by the foil thickness is regarded in the first order approximation as the stopping power at an average energy defined by

$$\bar{E} = E_0 - \Delta E/2,$$

where E_0 is the beam energy incident to the foil and ΔE is the energy loss in the foil.⁵⁾ If the incident velocities of protons and deuterons are exactly the same, the velocities will be different at the average energies. The velocity reduction for deuterons corresponding to $\Delta E/2$ will be about one half of that of protons. This effect was explicitly stated but not considered in detail in the previous work. However, it has been pointed out by Andersen¹²⁾ that this effect can not be ignored in our experimental conditions. In the present experiment, as will be described later, the sample foils corresponding to 400 to 500 keV absorption were used. On such conditions, if the incident velocities for protons and deuterons were exactly the same, the velocities at the average energies would differ by about 1 percent and then the Bethe theory would predict the stopping power for deuterons which is lower by about 2 percent than for protons.

In view of the experimental technique, it was considered that it is very difficult to make the velocities of protons and deuterons exactly equal to each other at the average energies. So that, it was decided to make the velocities of protons and deuterons incident to the foils exactly equal to each other in the same way as in the previous work. Then the effect of the difference of the velocity reduction was treated as a correction factor to examine the prediction of the Bethe theory.

The Kyoto University Cyclotron accelerates deuterons and molecular hydrogen ions up to about 14.5 MeV. To convert molecular hydrogen ions into protons, a thin aluminium foil of about 7 microns, the stripper, was inserted to the beam before the object slit S_1 . The velocity of protons is somewhat reduced by the insertion of the stripper. To compensate this reduction of proton velocity, an aluminium foil of about 15 microns was also inserted to the deuteron beam.

The beam from the cyclotron is spread in energy by about 1 percent. Therefore, when a sharply defined beam is selected out through the analyzing magnet, it is possible to adjust the velocity of the transmitted particles in the corresponding limited range. The velocities of protons and deuterons were made exactly equal by the following procedure.

The equations of motion for protons and deuterons in the analyzing magnetic field are

$$m_p v_p = e H_p \rho,$$

and

$$m_d v_d = e H_d \rho,$$

where m_p and m_d are masses of proton and deuteron of velocities v_p and v_d , H_p and H_d are the magnetic fields for protons and deuterons. The radius of curvature, ρ , is a constant proper to the apparatus. When

$$v_p = v_d,$$

$$H_d/H_p = m_d/m_p = m_{0d}/m_{0p},$$

where m_{0p} and m_{0d} are the rest masses of proton and deuteron. Thus, the ratio of the magnetic fields should be equal to the ratio of the rest masses in order to make the velocities exactly equal to each other.

From the mass data¹³⁾

$$m_{0d}/m_{0p} = 1.99900762 \pm 0.00000061.$$

During the measurement, efforts were put forth to keep the magnetic field as constant as possible. The average values of the resonance frequencies for protons and deuterons throughout the measurements were

$$f_d = 41.9529 \pm 0.0006 \text{ MHz},$$

and

$$f_p = 20.9866 \pm 0.0009 \text{ MHz},$$

respectively, where f_p and f_d are the resonance frequencies for protons and deuterons.

Hence,

$$H_d/H_p = f_d/f_p = 1.999032 \pm 0.000085,$$

in the present work. The respective velocities for protons and deuterons were $3.69693 \pm 0.00026 \times 10^9$ cm/sec and $3.69696 \pm 0.00027 \times 10^9$ cm/sec. Thus the velocities of protons and deuterons were equal to within 0.001 percent before the scattering. In the present work, however, the gold scatterer was thicker than the previous work by one order of magnitude*, so that the difference of velocity reduction for protons and deuterons in the scatterer made the agreement somewhat worse. This will be discussed later.

* The thin gold foil prepared beforehand was broken by accident in the beginning of the experiment.

3. Energy calibration of the pulse spectrum

The pulse height spectrum expanded by the biased amplifier was calibrated by recording the pulse height of protons and deuterons elastically scattered by an aluminium foil of 1.692 mg/cm² at various angles. In the present experiment, as already described, the energy loss of particles in the sample foils was about 500 keV. For protons scattering angles of 20 degrees to 100 degrees cover this energy range. For deuterons scattering angles of 20 degrees to 50 degrees were sufficient. The energy of the particles scattered at each angle was calculated by using relativistic kinematics with exact masses and the energy absorption in the scattering foil was estimated by using Bichsel's data.¹⁴⁾ In this case, too, the normal to the scatterer was set at an angle of one half the scattering angle to obtain the maximum resolution. The energy scale was crosschecked by a precision pulse generator which simulated the charge pulse from the silicon detector. The pulse generator was normalized by the detector pulse corresponding to the no absorber peak.

4. Sample foils

All sample foils were rolled ones. Square samples of 2 cm by 2 cm were cut out with a razor's blade. Each foil was weighed by a Mettler M-5 microbalance five times and the mean value was determined. The area of each foil was measured with Tiyoda LTG bi-AII microscope with a micrometer stage which can read to 1 micron. The area measurements were also made five times for each foil and the mean value was determined.

Thickness, purity and supplier of each foil is as follows:

Aluminium

Thickness: 10.1175 ± 0.0023 mg/cm². Stated purity: 99.8 percent. Supplier: Toyo Aluminium Co., Ltd.. The very same foil as used in the previous experiment.¹⁰⁾

Nickel

Thickness: 14.1663 ± 0.0014 mg/cm². Stated purity: 99.9 percent or up. Supplier: Fukuda Metal Foil and Powder MFG Co., Ltd..

Copper

Thickness: 14.8403 ± 0.0023 mg/cm². Stated purity: 99.9 percent or up. Supplier: Fukuda Metal Foil and Powder MFG Co., Ltd..

Rhodium

Thickness: 11.0943 ± 0.0029 mg/cm². Stated purity: 99.9 percent. Supplier: A. D. Mackay, Inc..

Silver

Thickness: 17.7369 ± 0.0015 mg/cm². Stated purity: 99.9 percent or up. Supplier: Fukuda Metal Foil and Powder MFG Co., Ltd..

Platinum

Thickness: 21.4658 ± 0.0071 mg/cm². Stated purity: 99.9 percent. Supplier: Ishifuku Metal Industry Co., Ltd..

Gold

Thickness: 20.3785 ± 0.0017 mg/cm². Stated purity: 99.95 percent. Supplier:

Ishifuku Metal Industry Co., Ltd..

III. RESULTS

The measurements were made twice for all samples for both protons and

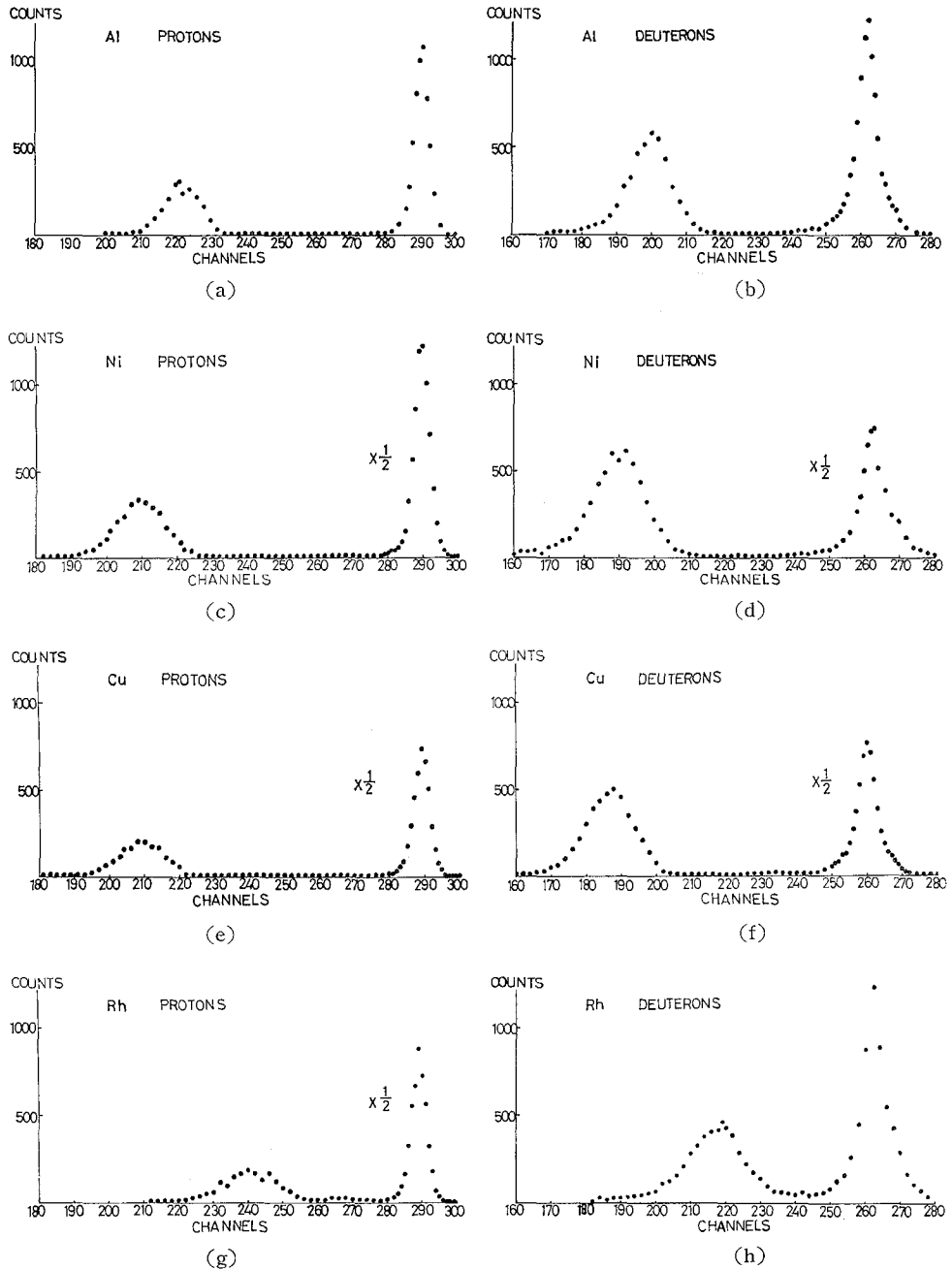

Fig. 2.

Stopping Powers for Protons and Deuterons

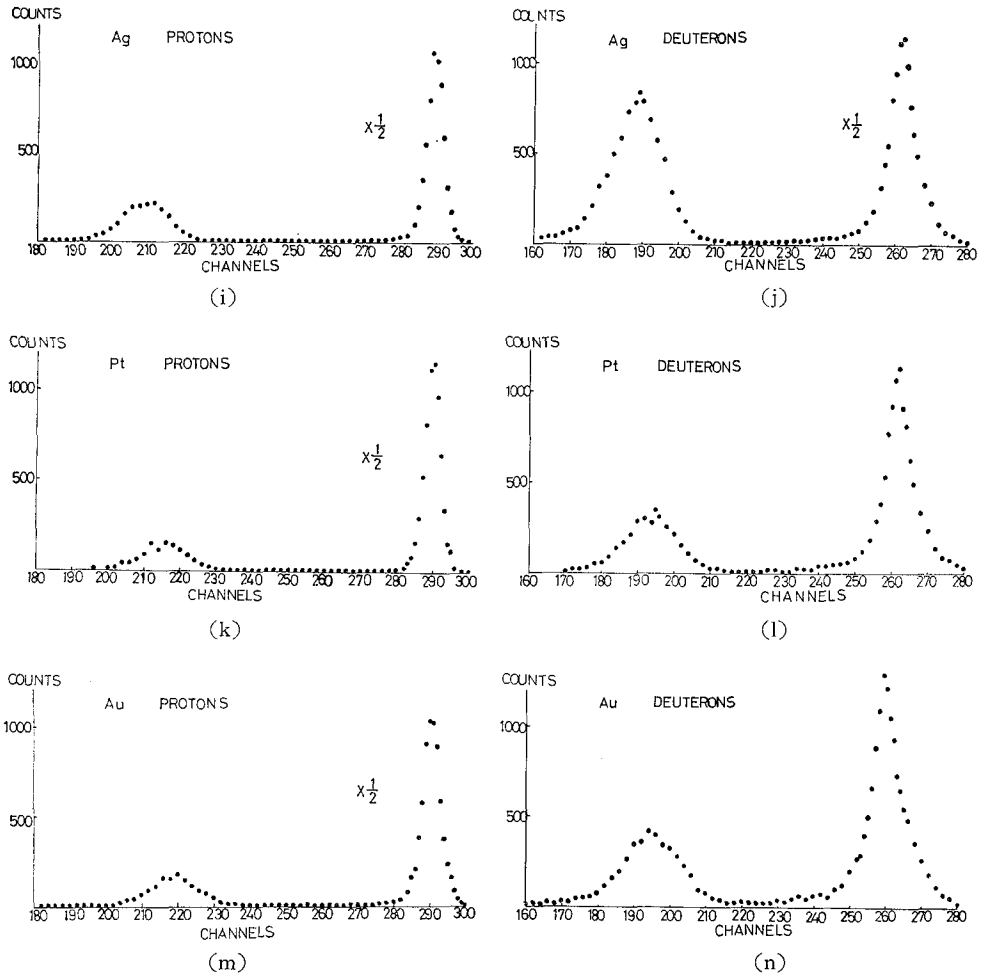

Fig. 2. Typical pulse height spectra for protons and deuterons.

deuterons.

Typical pulse height spectra are shown in Fig. 2. The width of the peak without the absorber is somewhat larger than expected from the momentum resolution of the analyzing magnet (0.1 percent). This is presumably due to the straggling effect in the rather thick gold scatterer. All peaks with absorbers are symmetrical and no effect of Vavilov skewness is observed. The pulse height is determined by taking the mean value. The pulse height difference was determined for each run and the mean value was calculated for the two determinations. The results are shown in Table 1 and 2.

The energy calibration for protons is shown in Fig. 3 as an example. The abscissa is the calculated particle energy and the ordinate is the pulse height in channel number. By assuming the linear relation between the pulse height and the energy, the slope of the straight line was calculated by the method of least squares. The results are

Table 1. The Pulse Height Difference for Protons. The Error Attached to the Average Value is the Standard Error.

Element	Pulse height difference (channel)		
	Run 1	Run 2	Average (channel)
Al	68.92±0.09	68.58±0.11	68.750±0.170
Ni	80.12±0.11	80.10±0.10	80.110±0.010
Cu	79.98±0.12	79.95±0.13	79.965±0.015
Rh	48.47±0.13	48.19±0.14	48.330±0.140
Ag	80.60±0.12	80.09±0.12	80.345±0.255
Pt	74.37±0.19	74.29±0.15	74.330±0.040
Au	71.72±0.20	70.89±0.13	71.305±0.415

Table 2. The Pulse Height Difference for Deuterons. The Error Attached to the Average Value is the Standard Error.

Element	Pulse height difference (channel)		
	Run 1	Run 2	Average (channel)
Al	62.77±0.14	62.91±0.09	62.840±0.070
Ni	73.41±0.10	73.61±0.09	73.510±0.100
Cu	73.61±0.17	73.75±0.09	73.680±0.070
Rh	45.03±0.08	45.02±0.09	45.025±0.005
Ag	73.80±0.11	74.01±0.08	73.905±0.105
Pt	68.87±0.15	68.82±0.11	68.845±0.025
Au	66.58±0.09	65.57±0.12	66.075±0.505

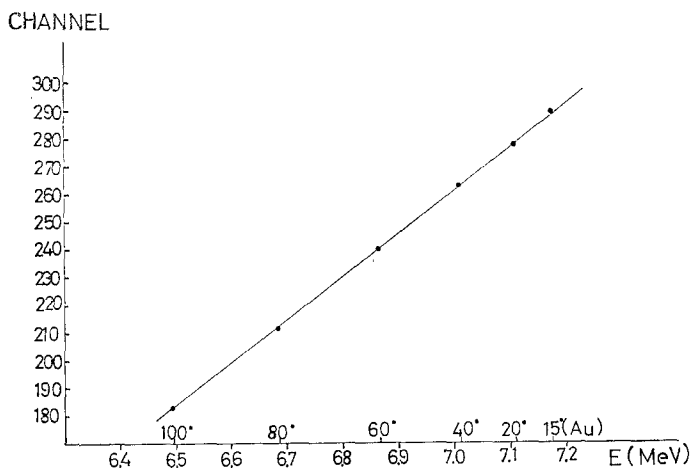

Fig. 3. The energy calibration for protons.

6.469±0.033 keV/channel for protons,
7.039±0.026 keV/channel for deuterons

respectively. The energy loss is obtained by multiplying the pulse height difference by these slopes.

The energies of protons and deuterons incident to the sample foils were

Stopping Powers for Protons and Deuterons

7.1756±0.0017 MeV and 14.3698±0.0029 MeV respectively. The corresponding velocities are 3.68658±0.00044×10⁹ cm/sec and 3.68985±0.00037×10⁹ cm/sec. The difference is 0.089 percent. As already mentioned, this difference was caused by the velocity reduction in the gold scatterer.

The results for protons and deuterons are shown in Table 3 and 4. In the tables, the average energy already mentioned is given in the second column. In Table 4 the proton energy which has the same velocity as deuterons of the average energy is given in the third column. In the fifth and sixth columns in Table 3 and 4. Andersen's values are given for the sake of comparison. In the sixth and seventh columns, the fractional difference between our results and Andersen's values are given. In order to use Andersen's values as reference standards, the fractional differences were calculated by deviding the difference by Andersen's value.

Table 3. The Results for Protons. The Incident Energy is 7.1756±0.0017 MeV.

Element	\bar{E} (MeV)	ΔE (keV)	$\frac{\Delta E}{\Delta x}$ (keV/mg cm ⁻²)	Andersen (keV/mg cm ⁻²)	Fractional Difference (%)
Al	6.9532±0.0021	444.7±2.5	43.95±0.25	45.04±0.14	-2.42±0.64
Ni	6.9165±0.0022	518.2±2.7	36.58±0.19	37.61±0.11	-2.74±0.59
Cu	6.9170±0.0022	517.3±2.7	34.85±0.18	35.42±0.11	-1.61±0.59
Rh	7.0193±0.0019	312.6±1.8	28.18±0.17		
Ag	6.9157±0.0023	519.7±3.1	29.30±0.18	29.72±0.09	-1.41±0.67
Pt	6.9352±0.0021	480.8±2.5	22.40±0.12	22.67±0.07	-1.19±0.62
Au	6.9450±0.0025	461.2±3.6	22.63±0.18	22.78±0.07	-0.66±0.83

Table 4. The Results for Deuterons. The Incident Energy is 14.3698±0.0029 MeV.

Element	\bar{E} (MeV)	\bar{E}' (MeV)	ΔE (keV)	$\frac{\Delta E}{\Delta x}$ (keV/mg cm ⁻²)	Andersen (keV/mg cm ⁻²)	Fractional Difference (%)
Al	14.1486±0.0030	7.0778	442.3±1.7	43.72±0.17	44.43±0.13	-1.60±0.47
Ni	14.1111±0.0031	7.0590	517.4±2.0	36.53±0.14	37.07±0.11	-1.46±0.49
Cu	14.1105±0.0031	7.0587	518.6±2.0	34.95±0.13	34.91±0.10	+0.11±0.46
Rh	14.2113±0.0030	7.1092	316.9±1.2	28.57±0.11		
Ag	14.1097±0.0031	7.0583	520.2±2.1	29.33±0.12	29.31±0.09	+0.07±0.51
Pt	14.1275±0.0030	7.0673	484.6±1.8	22.58±0.08	22.40±0.07	+0.80±0.49
Au	14.1372±0.0035	7.0721	465.1±3.9	22.82±0.19	22.53±0.07	+1.29±0.89

IV. DISCUSSIONS

As is seen from Table 3, Andersen's data are decisively higher than our proton data. The discrepancies are larger than twice the assigned experimental uncertainties for Al, Ni, Cu and Ag. Therefore, the discrepancies must be regarded as statistically significant with 5 percent significance level. All our experimental procedures and calculations were carefully rechecked. However, we could not find any sources of systematic error as large as 2 percent. We cannot but conclude that either Andersen's or our experimental procedure, or otherwise

each of them, contains some overlooked sources of systematic error of about 1 to 2.5 percent.

In the present experiment as well as in Andersen's, the absolute value of energy loss was independently determined for each element. So that, the relative stopping power values of ours and perhaps also of Andersen's are considered to be less reliable than purely relative stopping power measurement. This fact would explain the fluctuation of the discrepancy from 1 to 2.5 percent. As is seen from Table 1, in case of gold the repeatability of the two determinations is worse than other elements. So that our gold value is less reliable than other elements. Consequently, the discrepancy between our data and Andersen's should be said to be from 1 to 2.5 percent.

To return to the present subject, Table 4 shows that our deuteron data are decisively higher than the predicted values by the Bethe theory regarding Andersen's data as reference standards. Comparison with Table 3 shows that our deuteron data are higher by 1 to 2 percent than our proton data. As already mentioned, in our experimental conditions, the velocity of deuterons is higher than protons by about 1 percent at the average energy. In order to compare our deuteron data with proton data directly, we have assumed that the stopping power is proportional to $\ln v^2/v^2$ in a narrow velocity range, because the velocity independent part of the stopping power is a very slowly varying function of the energy. Then, by multiplying the deuteron data by $(\ln v_p^2/v_p^2)/(\ln v_d^2/v_d^2)$, the deuteron data are reduced to the values which correspond to the proton velocities at the average proton energies. The comparison is shown in Table 5. The deviations are clearly larger than twice the experimental uncertainties for all element except Al and are statistically significant.

Table 5. The Deuteron Stopping Power is Reduced to the Value Corresponding to the Proton Velocity and Compared with the Proton Stopping Power.

Element	Al	Ni	Cu	Rh	Ag	Pt	Au
$(dE/dx)_d$	44.48 ± 0.17	37.25 ± 0.14	35.64 ± 0.13	28.92 ± 0.11	29.91 ± 0.12	22.99 ± 0.08	23.23 ± 0.19
$(dE/dx)_p$	43.95 ± 0.25	36.58 ± 0.19	34.85 ± 0.18	28.18 ± 0.17	29.30 ± 0.18	22.40 ± 0.12	22.63 ± 0.18
Difference (%)	1.21 ± 0.68	1.83 ± 0.66	2.27 ± 0.63	2.63 ± 0.71	2.08 ± 0.75	2.63 ± 0.63	2.65 ± 1.15

From the present experiment, it should be concluded that the stopping power for deuterons is higher than for protons by about 1 to 2.5 percent at exactly the same velocity of which the approximate energies are 7.2 MeV and 14.4 MeV. The dependence of the deviation on the atomic number of the stopping material is not clear, but it can be at least said that for higher atomic number the deviation is higher. The deviation observed here is in the opposite direction as compared with the trend we have seen in Andersen's data.

At the present stage, it is difficult to explain this deviation from the Bethe theory by some assumed effects. However, it is not surprising that such devia-

Stopping Powers for Protons and Deuterons

tion does really exist, because the deviation¹⁵⁾ from the Bethe theory has been observed for alpha particles and He³ and this trend has been also confirmed by our own experiment.¹⁶⁾ It is here noted that in our experiment the energy calibrations for protons and deuterons were made independently to each other, although they are based on the same principle. However, this is also the case for Andersen's experiment as is explicitly stated in their paper.⁵⁾

More experimental data at varying energies will be necessary to confirm the conclusion proposed here.

It should be noted, however, in the previous experiment¹⁰⁾ on aluminium the energy calibration was common for protons and deuterons. Reanalysis of the previous experiment shows that the stopping power of Al for deuterons was higher than for protons by 0.95 ± 0.75 percent at exactly the same velocity. This deviation is not quite significant statistically, but its magnitude is nearly equal to that obtained in the present experiment.

V. ACKNOWLEDGMENT

The authors would like to thank Professor T. Yanabu for his encouragement and support throughout the work. Thanks are also due to Professor S. Yamashita for reading the manuscript and stimulating discussions. One of the authors (R.I.) expresses his heartfelt gratitude to Professor K. Goto, the ex-President of Nara Women's University, for continuous encouragement and support. Finally appreciation is due to Mr. K. Fujita and the members of the cyclotron crew for their kind cooperation.

Addendum

One of the possible sources of systematic error in the present experimental procedure is the disturbing effect of the undershoot of the pulse profile from the biased amplifier. Since the counting rate for the peak without the absorber is always higher than that for the peak with the absorber because of the multiple scattering effect in the absorber, the undershoot of the pulse profile may cause a trend which gives the too low value for the pulse height difference in case of high counting rate.

In the present experiment, the pulse profile has the width of 5 micro seconds and is accompanied by a slight undershoot. However, precautions were taken to make the measurement with sufficiently low counting rate. For proton measurements, the counting rate for the peak without the absorber was 90~271 cps and for the peak with the absorber was 18~108 cps. For deuterons the counting rate was somewhat higher because the effect of multiple scattering is smaller for deuterons than for protons. But the counting rate was kept less than 500 cps except for Run 1 of Rh, Run 2 of Ag and Run 1 and 2 of Au. Even in the latter cases the counting rate never exceeded 1000 cps.

For example, in the successive measurements of Ni and Pt made during about 1 hour the pulse heights for the peak without the absorber were 289.32 ± 0.05 channels for 242.7 cps, 289.38 ± 0.03 channels for 270.9 cps, 289.34 ± 0.03

channels for 89.2 cps and 289.35 ± 0.03 channels for 142.9 cps respectively while the integral pulse height corresponded to 1109.3 channels. In case of deuterons, in the successive measurements of Cu made during about 30 minutes the pulse heights for the peak without the absorber were 260.09 ± 0.07 channels for 107.1 cps and 259.98 ± 0.04 channels for 411.2 cps and the pulse heights for the peak with the absorber were 186.48 ± 0.16 channels for 75.1 cps and 186.32 ± 0.08 channels for 296.7 cps respectively while the integral pulse height without the absorber corresponded to 2041.5 channels.

The fluctuation of the amplifier gain in a long period of experiment was about ± 0.05 percent. So that the measurements with different counting rate made in a long period can not be compared directly.

From the above example, however, it is clear that the present measurement is definitely free from the disturbing effect of the undershoot of the pulse profile.

Further, the pulse height difference is never affected by the small fluctuation of the amplifier gain because the pulse height difference was measured simultaneously in one exposure.

REFERENCES

- (1) U. Fano, *Ann. Rev. Nucl. Sci.*, **13**, 1 (1963).
- (2) H. A. Wilcox, *Phys. Rev.*, **74**, 1743 (1948).
- (3) T. A. Hall and S. D. Warshaw, *Phys. Rev.*, **75**, 891 (1948).
- (4) T. Huus and C. B. Madsen, *Phys. Rev.*, **76**, 323 (1949).
- (5) H. H. Andersen, A. F. Garfinkel, C. C. Hanke and H. Sørensen, *Kgl. Danske Videnskab. Selskab, Mat.-Fys. Medd.*, **35**, No. 4 (1966).
- (6) H. H. Andersen, C. C. Hanke, H. Sørensen and P. Vajda, *Phys. Rev.*, **153**, 338 (1967).
- (7) H. H. Andersen, C. C. Hanke, H. Simonsen, H. Sørensen and P. Vajda, *Phys. Rev.*, **175**, 389 (1968).
- (8) H. H. Andersen, H. Simonsen, H. Sørensen and P. Vajda, *Phys. Rev.*, **186**, 372 (1969).
- (9) H. Bichsel, *Natl. Acad. Sci.-Natl. Res. Council Pub.*, 1133, p. 17 (1964).
- (10) R. Ishiwari, N. Shiomi, Y. Mori, T. Ohata and Y. Uemura, *Bull. Inst. Chem. Res., Kyoto Univ.*, **45**, 379 (1967).
- (11) A. Ritz, *Helv. Phys. Acta*, **34**, 240 (1961).
- (12) H. H. Andersen, Private communication.
- (13) L. A. König, J. H. E. Mattauch and A. H. Wapstra, *Nucl. Phys.*, **31**, 28 (1962).
- (14) H. Bichsel, *American Institute of Physics Handbook*, (McGraw-Hill, New York, 1963) 2nd ed.
- (15) H. H. Andersen, H. Simonsen and H. Sørensen, *Nucl. Phys.*, **A125**, 171 (1969).
- (16) R. Ishiwari, N. Shiomi, S. Shirai, T. Ohata and Y. Uemura, *Bull. Inst. Chem. Res., Kyoto Univ.*, **49**, 403 (1971).