

System of 7MeV-Proton Linac

Y. IWASHITA*, M. INOUE*, H. EGO*, H. OKAMOTO*, S. KAKIGI*, M. SAWAMURA**,
T. SHIRAI*, H. FUJITA*, K. FUKUNAGA*, and H. TAKEKOSHI*

Received August 3, 1990

The construction of a 7MeV-433MHz proton linac was started in 1986. The accelerator was installed in a new building on the Uji campus of Kyoto University in 1988. The accelerator system, the RF control system and the vacuum system are described.

KEY WORDS: RFQ linac/ Alvarez linac/ Proton linac/ RF control/ vacuum/

1. INTRODUCTION

A new accelerator was constructed at a new accelerator laboratory building of Institute for Chemical research (ICR) on the Uji campus of Kyoto University. It consists of a 2 MeV-RFQ linac^{1,2)} and a 7 MeV-Alvarez DTL³⁾. The main specification is shown in Table 1. The operating frequency is 433.3 MHz throughout the system.

Table 1

Ion source	
multicusp field type	proton 50 keV
Accelerating structure	
four vane RFQ	50 keV~2 MeV
vane length	2195 mm
cavity inner diameter	170 mm
characteristic radius	3 mm
min. bore radius	2 mm
intervane voltage	80 kV
transmission efficiency	95% (at 30 mA)
DTL (Alvarez)	2 MeV-7 MeV
cavity length	1868 mm
number of drift tubes	28
focusing Q magnet	NdB iron permanent magnet
RF power source	
frequency	433.3 MHz
peak power (for each tube)	1 MW
repetition rate	<180 Hz
duty factor	1 %
Klystron	Litton L-5773

* 岩下芳久, 井上 信, 恵郷博文, 岡本宏巳, 柿木 茂, 白井敏之, 富士田浩一, 福永清二, 竹腰秀邦:
Nuclear Science Research Facility, Institute for Chemical Research, Kyoto University

** 沢村 勝: Japan Atomic Energy Research Institute

System of 7 MeV-Proton Linac

The frequency is about twice higher than conventional DTLs and the size is about a half of them.⁴⁾ Klystrons are available for such higher frequency as high power RF sources. A higher energy accelerating cavity is planned to be connected after the DTL in the future. The operating frequency of the high- β structure should be 1.3 GHz, which is three times higher than that of the low energy part, and it allows the simultaneous acceleration of both positive and negative ions.

The area of the new accelerator building space is 2650 m² in total, and the shielded

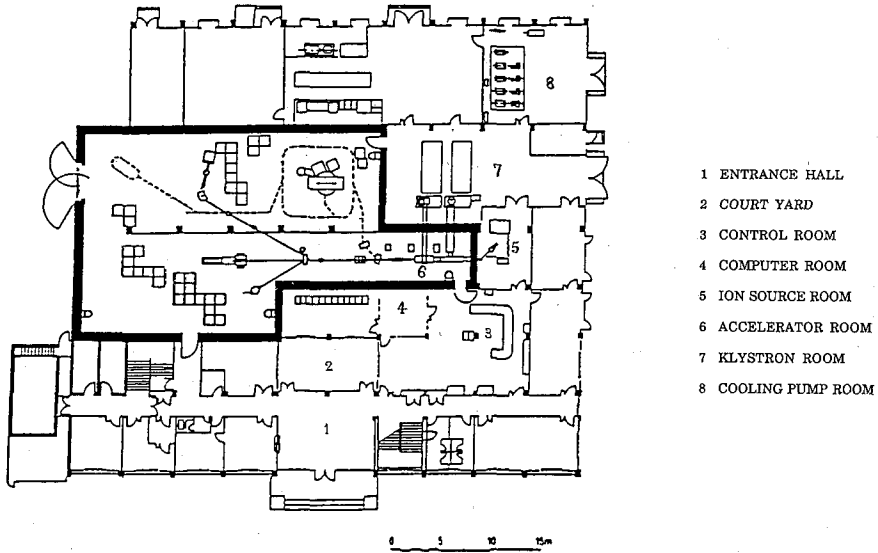

Fig. 1. Plan view of the Accelerator Laboratory (1F)

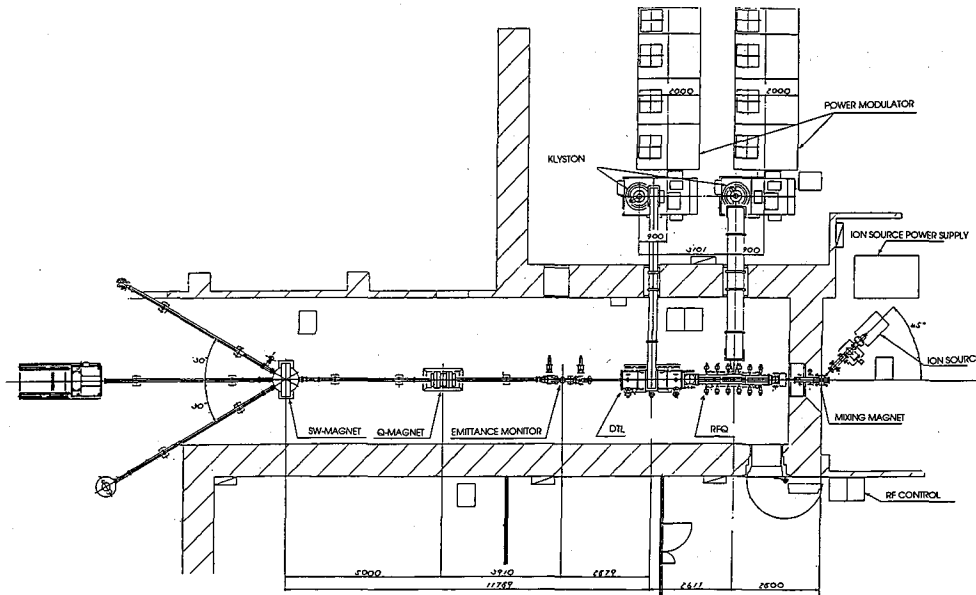

Fig. 2. Layout of the accelerator system.

area surrounded by 1 meter thickness wall is 600 m². The compact size of the accelerator saves enough area for future developments as shown in Fig.1. The Fig.2 shows the layout of the main part of the accelerator system.

2. ACCELERATOR SYSTEM

INJECTOR

A multicusp-field ion source is used to produce 50 kV H⁺ ion. The arc voltage of the ion source is switched for pulsed operation of up to 10% dutycycle. The designed peak beam current is 60 mA. There is an einzel-lens and a pair of x-y steering electrodes after a 50 kV accelerator column. For the future simultaneous acceleration of positive and negative ions, the low energy beam transport (LEBT) has a 45 degree mixing magnet. After the mixing magnet, a solenoidal focus coil is used to match the beam phase space configurations to the RFQ.

RFQ

The 4-vane RFQ is operated at the frequency of 433.3 MHz. The outer wall and the vanes are made of CrCu (Cr 0.75, Zr 0.08) which has 80% electric conductivity of Cu and 80% Young's modulus of stainless steel. The vane tips are machined with a concave cutter and have a constant curvature along the axial direction. Each vane has a 20 mm diameter cooling channel in it. For field distribution tuning, 6-plug-tuners are installed in each quadrant. The designed intervane voltage is 80 kV. The RF power is generated by an 1MW-peak-power Klystron L-5773, and coupled through WR-2100 waveguide by a loop into the RFQ cavity after a waveguide-to-coaxial line transition. The measured Q value is 5000, while SUPERFISH result is Q=6600.

Beam Matching Section

Permanent quadrupole magnets are used to focus the output beam from RFQ. Four of them are installed before a buncher and another four quadrupole magnets are installed before the DTL cavity. The buncher is needed to match the beam to the longitudinal acceptance of the DTL. Beam monitors will be installed in this section to investigate the output beam from the RFQ.

DTL

The tank is made of standard Cu, and the drift tubes are made of OFC. The stems are made of CrCu. The drift tube diameter is 55 mm and the bore radius is 5 mm. Permanent quadrupole magnets are installed in the drift tubes to focus beams. Each drift tube is supported by a stem from the bottom plate which is demountable from the tank. The 28 drift tubes were aligned on the plate before installation into the tank. The 5 tuners of 10 cm diameter are installed in the tank. Two of them are fixed, and three are tunable. The klystron L-5773 is also used as the power source and the power is coupled by a 5 cm width slot on the tank top. The slot length is about 15 cm. The coupling Q value is shown in Fig.3 as a function of slot length. The

System of 7 MeV-Proton Linac

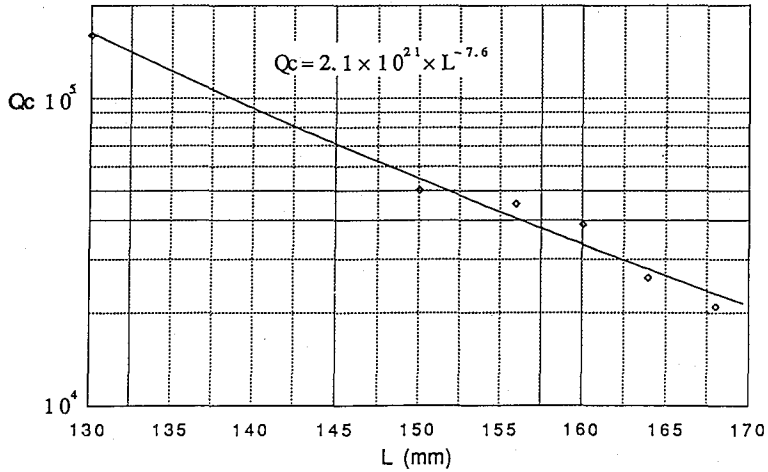

Fig. 3. Coupling Q of DTL as a function of slot length

unloaded Q is about 38000. The average accelerating field is 3MV/m.

3. RF CONTROL SYSTEM

A schematic block diagram of the RF control system is shown in Fig.4. The base RF is generated by an SSG HP865B and the operating frequency is phase locked to the RFQ cavity resonance frequency. The RF phase of each cavity is also phase locked to the base SSG phase. For resonance control, the tuner can be adjusted by phase

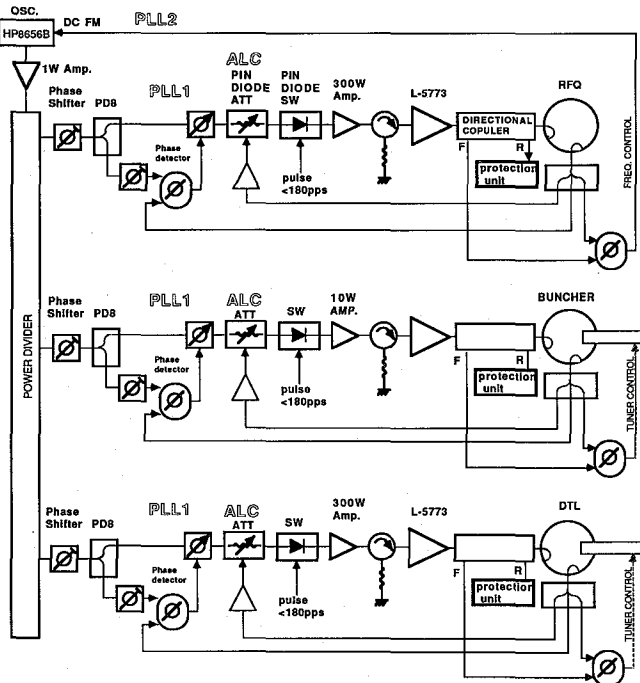

Fig. 4. RF control system

difference between the input RF and the RF in the cavity. The relative phase of each cavity is adjustable. Each klystron needs up to 300W RF input to generate 1MW RF, and the 300W RF power is generated by an FET amplifier respectively. To keep the RF voltage constant, the input power to the klystron is controlled by AGC circuit. ECL D-flipflops are used for the phase detectors, and the detecting range is ± 180 degrees.

4. VACUUM SYSTEM

Fig.5 shows a block diagram of the vacuum system. A 500-liter/s turbo molecular pump (TMP) is used for the ion source, and a 150-liter/s TMP is installed at the LEBT section. Both turbo pumps have the ordinary bearing system.

Because of the poor vacuum conductance through the RFQ tank, the pumps are installed at both the entrance and exit side. To evacuate the RFQ tank, a 270 liter/s turbo molecular pump is installed at the entrance side, and a 700-liter/s cryo pump (2400-liter/s for H_2O) is also installed at the RFQ exit side. At the DTL thak, a 400-liter/s TMP is installed. Both turbo pumps are oil free with magnetic floating rotars. A 160-liter/s ion pump is also installed at each RF feeder. One is at the bottom of the waveguide-coax transition of the RFQ and another is at the coupling slot of the DTL.

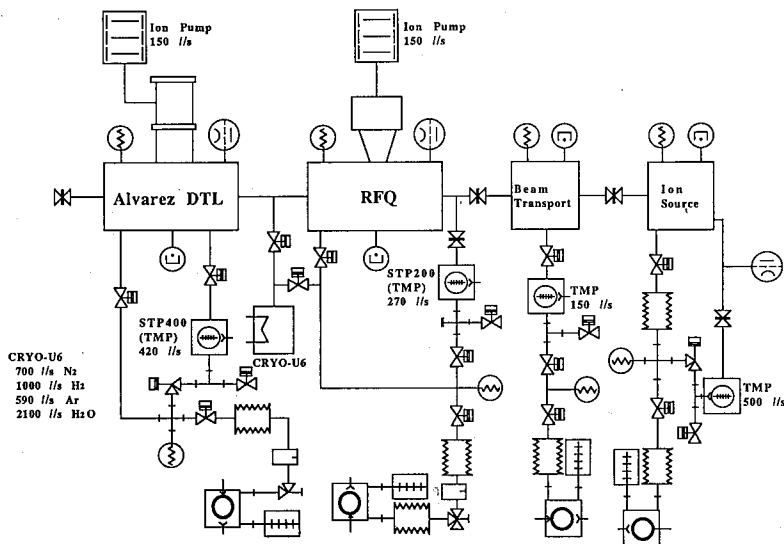

Fig. 5. Vacuum system

5. ACKNOWLEDGMENT

The authors would like to thank Dr. R. A. Jameson at Los Alamos for his continuous encouragement and help.

The entire system was constructed by Sumitomo Heavy Industry. The klystron pulse power supplies were manufactured by Nissin Electric Co. Ltd., and RF control

units by R & K Co. Ltd. The patient co-operation and skilled working of the staffs of these companies are especially acknowledged.

REFERENCES

- (1) H. Okamoto, et al.: "Design of 433.3-MHz Proton RFQ Linac", *Bull. Inst. Chem. Res. Kyoto Univ.* **65**, No.1 (1987)
- (2) M. Sawamura, et al.: "RF Characteristics of 433.3-MHz Proton RFQ Linac", *Bull. Inst. Chem. Res. Kyoto Univ.* **66**, No.1 (1988)
- (3) M. Sawamura, et al.: "Design of 433.3-MHz Alvarez Drift Tube Linac and Beam Matching Section", *Bull. Inst. Chem. Res. Kyoto Univ.* **66**, No.1 (1988)
- (4) L. D. Hansbrough, Compiler, "PIGMI: A Design Report for a Pion Generator for Medical Irradiation", LANL report LA-8880 (1980).