

## Development Plan of Basic Technology For a High Intensity Proton Linear Accelerator

M. MIZUMOTO and N. SHIKAZONO

*Received July 23, 1990*

Various applications have been recently considered using a high intensity proton linear accelerator in the field of nuclear technology. In particular, nuclear spallation reactions with a high energy proton beam are expected to be useful for transmutation of radio active transuranium (TRU) nuclear wastes. In this report, the basic concept of the transmutation system and the development plan for the accelerator technology at Japan Atomic Energy Research Institute, JAERI, will be briefly described.

**KEY WORDS:** Proton linear accelerator/ Transuranium transmutation/ RFQ linac/ DTL linac/ Design consideration/

### 1. INTRODUCTION

The national program called OMEGA (Options Making Extra Gains of Actinides and Fission Products) has started by aiming at promoting the research and development of the new technologies on nuclear waste partitioning and transmutation. As a part of this program, JAERI has laid out several R & D plans for accelerator based actinide transmutation.

In this proposal, nuclear spallation reactions with high energy (say above 1 GeV) proton beams are considered for the effective transmutation processes. The need for the development of a high-energy and high-current proton linear accelerator is, therefore, stressed for that purpose. Such a high intensity proton accelerator is also expected to contribute to other various nuclear research fields. Nuclear spallation reactions with high energy proton beams will produce intense neutron fluxes, that, in turn, can be utilized for the production of nuclear fuels in addition to the nuclear waste transmutation. Applications to nuclear data measurement, material science, radio isotope production and muon catalyzed fusion will be also carried out using these secondary neutron, muon and pion beams.

### 2. The nuclear waste transmutation system

The basic concept of the TRU transmutation system with proton spallation reactions has been studied at JAERI for the last several years<sup>1)</sup>. The main goal of this program is to process the TRU of which the yearly production rate is typically 30 kg for a 1000 MWe LWR. The neutronics calculation and power dissipation calculation

---

水本元治, 鹿園直基: Tokai Research Establishment, Japan Atomic Energy Research Institute  
Tokai-mura, Naka-gun, Ibaraki-ken

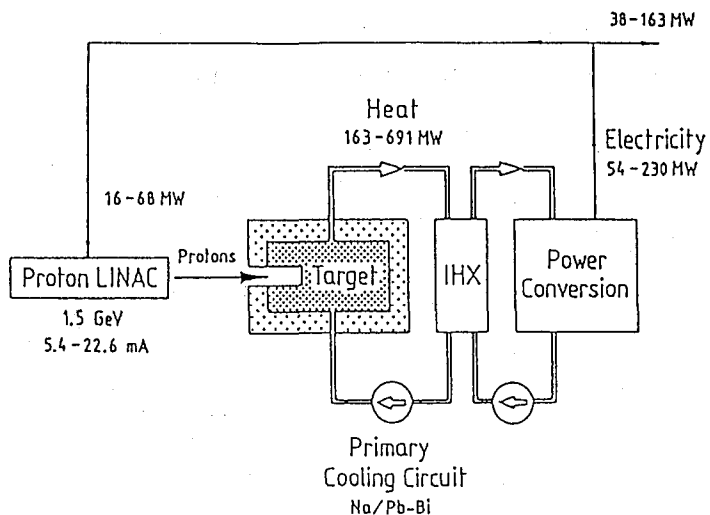

Fig. 1. Actinide transmutation system with proton accelerator

were carried out as given in elsewhere<sup>2-4</sup>.

Figure 1 shows a model for an accelerator driven target system in combination with a subcritical reactor. The proton energy is taken 1.5 GeV, a value that has been estimated to be the most efficient from the preliminary calculations. The target and fuel assembly in the reactor are similar to that used for the common fast breeder reactor. Two kinds of coolant materials, Na and Pb-Bi, are used in the calculations. A harder neutron spectrum is preferable in order to make the transmutation more effective, because the fission reaction rate exceeds the capture rate for increasing the neutron energy.

Primary nuclear spallation reactions and the subsequent particle transport processes were simulated using the NMTC/JAERI code<sup>5</sup> for the neutron energy range above the cutoff energy of 15 MeV. Below this energy, a three dimensional Monte Carlo transport code was used. The  $k_{eff}$  value was taken in the range of 0.86-0.95 for the calculation.

Two-dimensional thermal hydraulic calculations were made for Na and Pb-Bi cooled targets. The maximum achievable thermal power was limited by a maximum allowable temperature that was set at 900°C in the fuel and cladding. The calculated maximum thermal output powers were 405 MW and 163 MW for Na and Pb-Bi cooling, respectively. Accordingly the averaged power densities were 159 W/cc and 83 W/cc using the incident proton beam current of 18.2 mA and 5.4 mA.

In addition to these reference target assemblies, the tungsten loaded assemblies were also considered to make the power density flat. The maximum thermal power can be increased by about a factor of 2 by introducing the tungsten. The two dimensional power distribution profile is shown in Fig. 2. The power output for Na was found to be considerably higher than that of Pb-Bi due to the effective cooling capability of sodium. The calculated results were summarized in Table 1.

From these calculations, the spallation neutrons and the subsequent induced

fission neutrons can transmute the TRU produced by 4–8 LWR in a Na cooled subcritical assembly. As a by-product, this system can be used to produce excess electric power of about 50–200 MW, a part of which can be used to operate the proton accelerator.

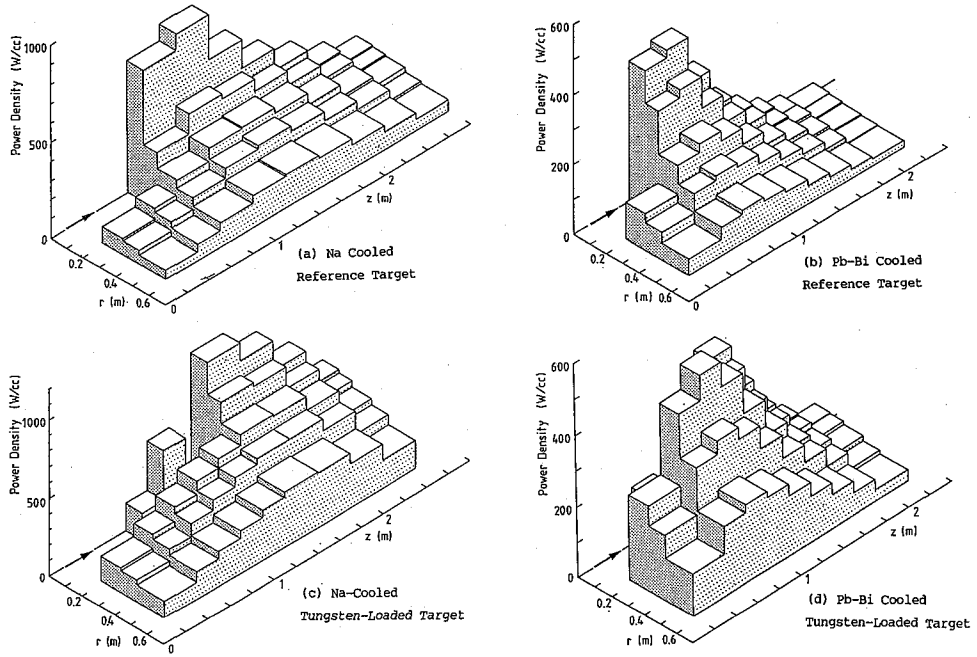

Fig. 2. Calculated power distribution

Table 1 Performance of Incineration Plant.

Target system	Tungsten-loaded		Reference	
	Na	Pb-Bi	Na	Pb-Bi
Effective multiplication factor	0.92	0.86	0.94	0.95
Pin pitch (mm)	9.5	10.5	10.5	12.0
Actinide loading (kg)	2866	2013	2682	1584
Beam current (mA)	22.6	7.5	18.2	5.4
Neutrons per proton	38.1	52.8	35.3	55.1
Average neutron flux ( $\times 10^{15}n/cm^2 \cdot sec$ )	4.6	6.6	2.0	1.9
Actinide burnup (kg)	202	139	114	42
Unit of 3000 MWt LWR	7.6	5.3	4.3	1.8
Thermal Power (MWt)	691	342	405	163
Average Power Density (W/CC)	307	174	159	83
Coolant Temperature (°C) outlet	389	441	352	377
Clad Temperature (°C) max.	492	614	481	589

### 3. ACCELERATOR DEVELOPMENT.

The conceptual design of the Engineering Test Accelerator (ETA) for the TRU

transmutation system has been proposed by JAERI with a beam energy of 1.5 GeV and a current of 10 mA. This accelerator represents a large scale system when compared to the contemporary proton accelerators that are used mainly for basic nuclear physics experiments. In particular, an average proton beam current of 10 mA is nearly 10–50 times larger than that for existing accelerators.

To obtain such high beam current, only a linac can meet the necessary requirements. Other circular accelerators such as a cyclotron or synchrotron accelerate much smaller beams with maximum currents of about 1 mA. Beam spill can not be controlled effectively in the case of circular accelerators, and will cause serious problems due to the high level activities induced in the accelerator structures.

As the first step in the development, the low energy portion of the accelerator structure will be studied, since the beam quality is determined mainly by this portion. This Basic Technology Accelerator (BTA) will consist of the following components; ion source, radio frequency quadrupole (RFQ) and drift tube linac (DTL) as shown in Fig. 3. The beam energy is chosen to be less than 10 MeV, below the Coulomb barrier, to avoid the proton induced reactions in the accelerator structural materials.

In the 2nd step, a proton accelerator for research purposes (Engineering Test Accelerator, 1.5 GeV, 10 mA) will be designed and constructed. The various engineering tests of the transmutation process, including medium and large scale integral test, mock-up test and prototype experiments, will be made using this accelerator. The high energy portion of the accelerator (high beta structure) will be also studied in advance of the 2nd stage development.

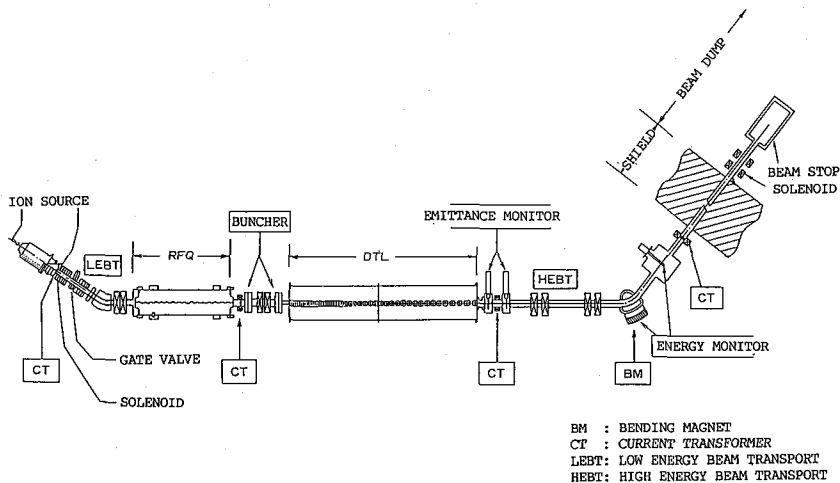

Fig. 3. Basic Technology Accelerator (10 MeV, 10 mA)

#### 4. THE SUMMARY AND WORKS CARRIED OUT IN 1989 AND 1990.

The survey activities and preparatory design studies are being continued through 1989 and 1990. The studies for the optimization of the accelerator system and the conceptual design of accelerator structures will be started in 1990 followed by various

R & D activities. The main items for the works will be summarized as follows,

- 1) Survey activities on present status of high intensity proton accelerators.
- 2) Preparation and test run for design calculation computer programs.
- 3) Preliminary beam dynamics calculation based on previous or on-going proton accelerator projects. The parameters temporarily chosen for the RFQ and some calculated results are given in Table 2. The results of the beam dynamics

Table 2 Preliminary parameters for the RFQ test calculations.

1. Frequency	135 MHz
2. Injection energy	50 keV
3. Output energy	2.0 MeV
4. Input current	110 mA
5. Vane voltage	0.17 MeV/m
6. Vane length	198 cm
7. Minimum bore radius	0.453 cm
8. Maximum modulation	2.31
9. Input tran. emitt.	0.5 $\pi$ mmrad (100%)
10. Output trans. emitt.	1.7 $\pi$ mmrad (90%)
11. Quality factor	13477
12. Wall loss	283 kW

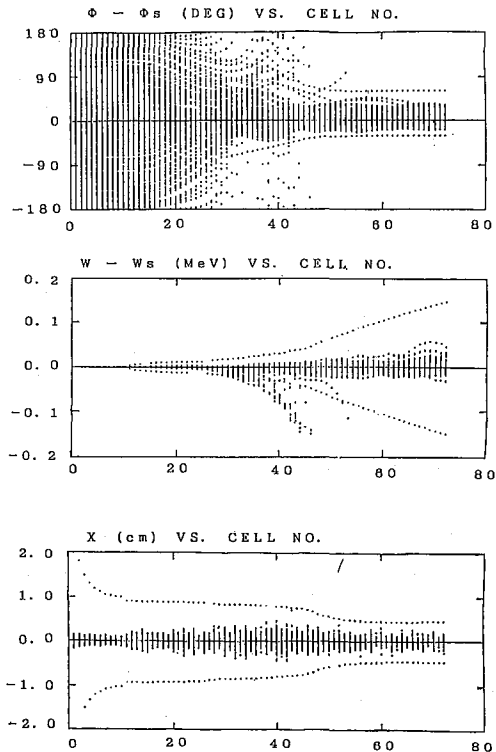

Fig. 4. The test calculation for RFQ beam dynamics with PARMTEQ.

calculation by PARMTEQ are shown in Fig. 4.

- 4) Consideration of operation mode (CW, duty cycle, RF frequency, energy configuration etc.)
- 5) Estimation of utilities such as electricity, water consumption, space required for building.
- 6) System studies of Basic Technology Accelerator.
- 7) Conceptual design studies of accelerator elements: Ion source, RFQ, DTL, RF power source, Control system.
- 8) Target system studies with high energy nuclear data, damage data, heat calculation.
- 9) Trade-off studies of Engineering Test Accelerator.

#### Acknowledgment

This report is based on the works carried out by the Nuclear Spallation Study Group in JAERI. The authors wish to thank Dr. Y. Kaneko, Department of Reactor Engineering and the group members for providing the information about the TRU transmutation system.

#### REFERENCES

- (1) T. Nishida et al., "Research of TRU transmutation System with Proton Accelerator" NEA/CRP, 1989.
- (2) Y. Kaneko, "The Intense Proton Accelerator Program", The 2nd Int. Symp. on Advanced Nuclear Energy Research, Mito, 1990.
- (3) H. Takada et al., "A Conceptual Study of Actinide Transmutation System with Proton Accelerator, (1) Target Neutronics Calculation", *ibid.*
- (4) T. Takizuka et al., "A Conceptual Study of Actinide Transmutation System With Proton Accelerator, (2) Target Thermal Hydraulic", *ibid.*
- (5) Y. Nakahara et al., "NMTC/JAERI A Simulation Code System for High Energy Nuclear Reactions and Nucleon Meson Transport Processes", JAERI-M 82-198 (1982)