

Characteristics of the Ion Source and Low Energy Beam Transport of the Proton Linac at ICR

Akira NODA, Yoshihisa IWASHITA, Hirokazu FUJITA,
Hiromi OKAMOTO, Shigeru KAKIGI, Toshiyuki SHIRAI
and Makoto INOUE

Received February 9, 1993

The ion source of the ion linear accelerator is modified in its magnetic field for plasma-confinement and by replacement of the power supply, it is operated in pulse mode with maximum duration and rating of 500 μ sec and 180 Hz, respectively. For the condition of arc current of 40 A, the current of 50 keV beam amounts to 10 mA just at the exit of the extraction hole, of which 3 mA is measured to be H^+ beam. By the ion optics composed of discrete focusing elements, the H^+ beam current of ~ 1 mA is able to be transported to the RFQ, while cure for the space charge effect is needed for much higher current more than 10 mA.

KEY WORDS: Arc Current/ Plasma Density/ Einzel Lens/ Electrostatic Quadrupole/
Solenoid/ Space Charge Force

1. INTRODUCTION

Following the completion of construction of the 7 MeV proton linac,¹⁾ main efforts this year is oriented to increase the beam intensity and study the beam characteristics in more detail. The latter is presented elsewhere^{2,3,4)} and the scope of the present paper is the work related to beam intensity and transmission.

As the extraction voltage from the ion source is rather lower value as 50 kV, the extracted beam is largely affected by space charge repulsion if the extracted beam current increases. Thus it is inevitable to increase the abundance of H^+ so as to realize efficient extraction and transport of high current beam. For this purpose, it is necessary to increase the plasma density by making higher arc current and improving the confinement of the plasma. Magnetic field for plasma confinement is being modified and a new power supply which enables the high arc current is newly fabricated.

The current of the linac is not limited only by capability of the ion source, but is suffered from the effect by space charge blow up in the beam line between the ion source and the linac. This year, efforts are made to attain the limiting current by the present ion optics constructed based on discrete focusing elements, which is designed assuming the lower beam current without space charge effect for the moment.

野田 章, 岩下芳久, 富士田浩一, 岡本宏巳, 柿木 茂, 白井敏之, 井上 信: Nuclear Science Research Facility, Institute for Chemical Research, Kyoto University.

2. ION SOURCE

From the experience up to now, it has been known that high plasma density is needed in order to extract a high current H^+ beam with good emittance. From this point of view, permanent magnets are attached around the through hole of the plasma chamber as shown in Photo 1 in order to improve the plasma confinement and a new power supply capable of the operation with pulse-arc is newly fabricated in order to avoid the technical difficulty of cooling necessary for high arc current with DC operation. In Fig. 1, a typical block diagram of the power supply is shown. DC power supplies for filament (10 V, 150 A), biasing (60 V, 3 A) and a pulsed switch for the arc are mounted on a high voltage terminal of 50 kV and they are controlled by a control panel composed of a personal computer (PC-9801) interfaced with up-down switches. The control panel is connected to the power supplies through GP-IB interface electrically isolated with an optical cable. In addition, a gas flow controller made of a piezo-resistor has also been added in order to investigate the performance of the ion source quantitatively. An overall view of the power supply is shown in Photo 2.

Operating with the power supply, it is found that aging of the ion source with making arc during a few hours is necessary in order to attain tolerable amount of abundance of H^+ beam whenever the operation of the ion source is stopped even if the ion-source chamber is kept in good vacuum (in the order of 10^{-7} Torr). Without baking, even if the gas flow rate is increased, the fraction of H^+ does not become high enough.

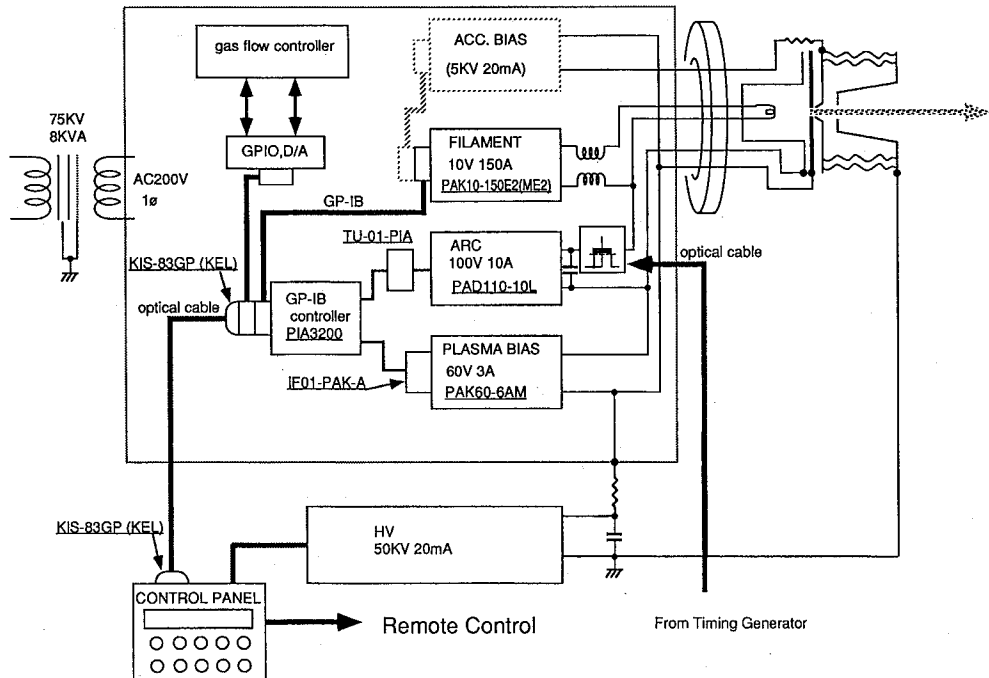

Fig. 1. Block diagram of the newly fabricated power supply capable of pulse-mode operation for the ion source.

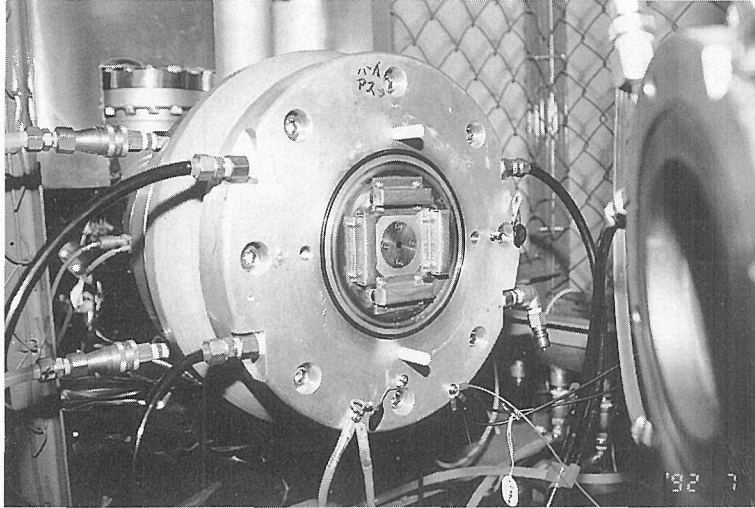

Photo. 1. Four rods of permanent magnets attached on the plasma chamber around the through-hole for ion-extraction for the purpose of improvement of plasma confinement. They are mounted in containers of coppers in order to attain good thermal contact with plasma chamber, which is water-cooled.

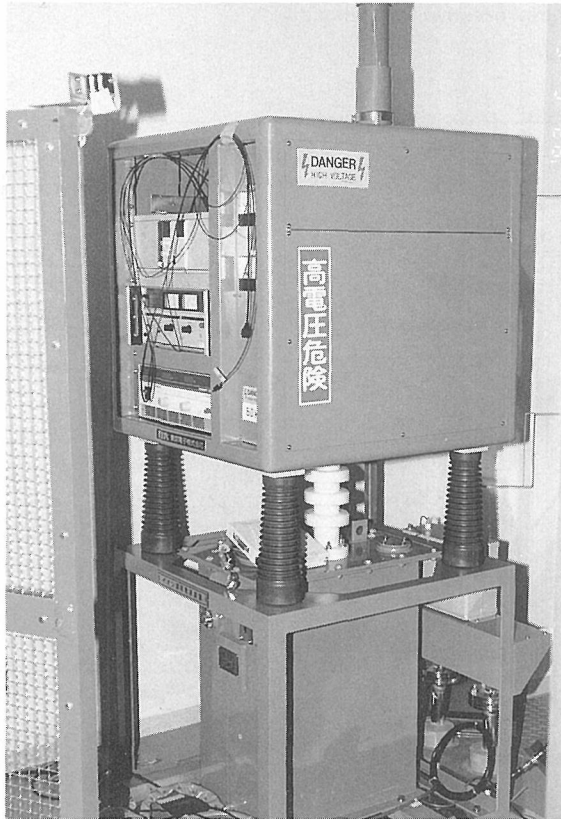

Photo. 2. An overall view of the new power supply of the ion source.

Ion Source and Low Energy Beam Transport

After the aging, the gas flow rate of H_2 is kept at a few times of 0.1 cc per minute. So as to extract the ions in a rather limited transverse phase space, the geometry of the extraction electrode is important in connection with the plasma density inside the ion-source chamber. The electric field around the extraction hole made by the high voltage of 50 kV for the extraction should be in good balance with the plasma-pressure so that the plasma boundary becomes a concave to inside of the chamber. In order to clarify this situation more quantitatively, the extracted beam currents are measured for three geometries with various arc currents and extraction voltages. The results are given in Fig. 2. The gap between the extraction electrode (with earth potential) and the plasma chamber wall (with the high-voltage potential) is 23 mm for the case (a) and 15 mm for cases of (b) and (c). The diameter of the through-hole for extraction of the beam made on the plasma chamber is 3 mm for cases (a) and (c) and it is 2 mm in the case (b). From each figure, it is evident that higher electric field realizes good plasma boundary for higher arc currents (well considered to corresponds to higher plasma densities). Comparing Fig. 2(a) and (c), it is known that smaller gap size, which leads to a stronger electric field and balances with higher plasma density, results in a high extracted current. The data in Fig. 2(b) shows the trivial fact that with a smaller (2 mm ϕ) through-hole, the extracted current becomes smaller proportional to the ratio of the area of the through-hole. With the geometry of Fig. 2(c), the arc current has been increased up to 40 A with the gas flow rate of 0.5 cc per minute and filament current of 97 A through two parallel-connected tungsten filaments 1.0 mm in diameter and 10 cm in length. Under the above condition, extraction current of 10 mA is attained, although only $\sim 30\%$ of which is measured to be H^+ beam. In Fig. 3(a), a picked up signals of the arc current and the extracted current are shown. As is known from the figure, the duration of the arc is 500 μsec . The maximum rating is determined to be 180 Hz which is the same as the linac system.

3. LOW ENERGY BEAM TRANSPORT SYSTEM

The beam transport line from the ion source to the entrance of the RFQ, which is called Low Energy Beam Transport (LEBT), is composed of an einzel lens, two triplets of electrostatic quadrupoles (ESQ and [QF3, QD3, QF4]), two doublets of electrostatic quadrupoles ([QF1, QD1] and [QF2, QD2]), a bending magnet with 45° deflection angle (mixing magnet) and a solenoid as shown in Fig. 4. The beams extracted from the ion source is made to be a parallel beam by the focusing action of the einzel lens, the applied potential of which is up to 31 kV. The beam is focused by an electrostatic triplet (ESQ) so that it can pass through the narrow aperture (26 mm in height) of the chamber inside the mixing magnet. As described in the previous section, among the 10 mA beam extracted from the ion source, only 3 mA is H^+ and is bent to the right direction by the mixing magnet. The H^+ beam is further focused by two doublets, a solenoid and a triplet in order to make transverse phase space matching. At the moment, the final triplet is not yet installed and the transverse phase space matching is not complete. The behaviour of β -functions in horizontal and vertical directions are calculated as shown in Fig. 5 by black and open circles, respectively. Experimentally the H^+ beam of 3 mA is measured to be reduced to 1.2 mA at the position in front of the final triplet (Faraday Cup 4 shown in Fig. 4), which is considered to be due to the effect of space charge repulsion, because the horizontal beam size becomes too small in the mixing magnet as is known from Fig. 5. In Fig. 3(b), the measured

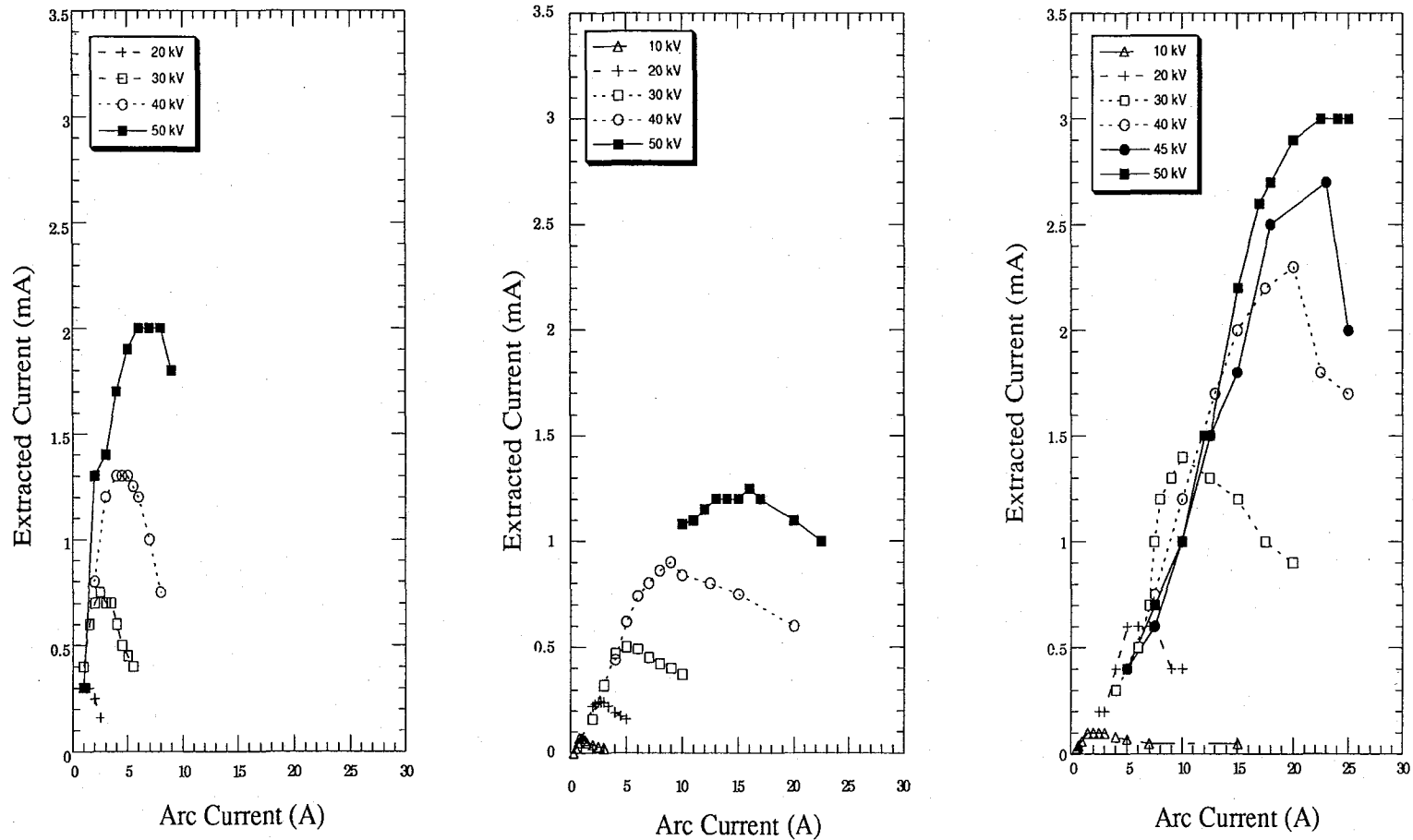

Fig. 2. Dependence of the extracted beam currents on the arc current for various extraction voltages for three geometries of (a) gap=23 mm, hole=3 mm ϕ , (b) gap=15 mm, hole=2 mm ϕ , and (c) gap=15 mm, hole=3 mm ϕ , where gap and hole mean the gap between the extraction electrode (earth potential) and the plasma chamber (50 kV) and the through-hole for beam extraction made on the plasma chamber, respectively.

Ion Source and Low Energy Beam Transport

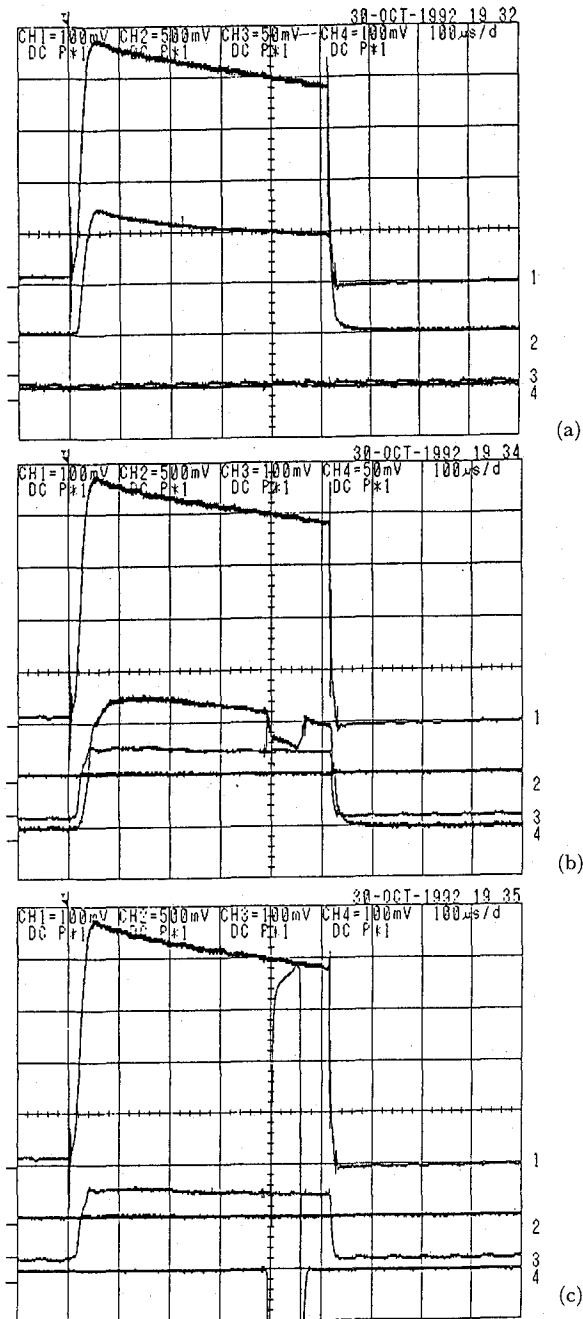

Fig. 3. (a) Picked up signals of the arc current (trace 1) and the extracted current (trace 2). The vertical scale is 10 A/div. and 5 mA/div. for traces 1 and 2, respectively and the horizontal scale is 100 μ s/div. (b) Picked up signal of the beam transported to the entrance of the RFQ (trace 4). The horizontal and vertical scales are 100 μ sec/div and 0.5 mA/div., respectively. The dip in the signal of the duration of 60 μ sec is due to the background caused by electrons emitted by the high RF power fed into the linac cavity. The trace 1 is the arc current which is the same as (a). The trace 3 is the observed current of heavier ions than H^+ observed by Faraday cup 3 pulled out to the position to pass through the H^+ beam. (c) Picked up signal of the accelerated beam with the RFQ observed by Faraday Cup 5 (trace 4). The horizontal and vertical scales are 100 μ sec/div. and 100 μ A/div., respectively. Traces 1 and 3 are the same as (b).

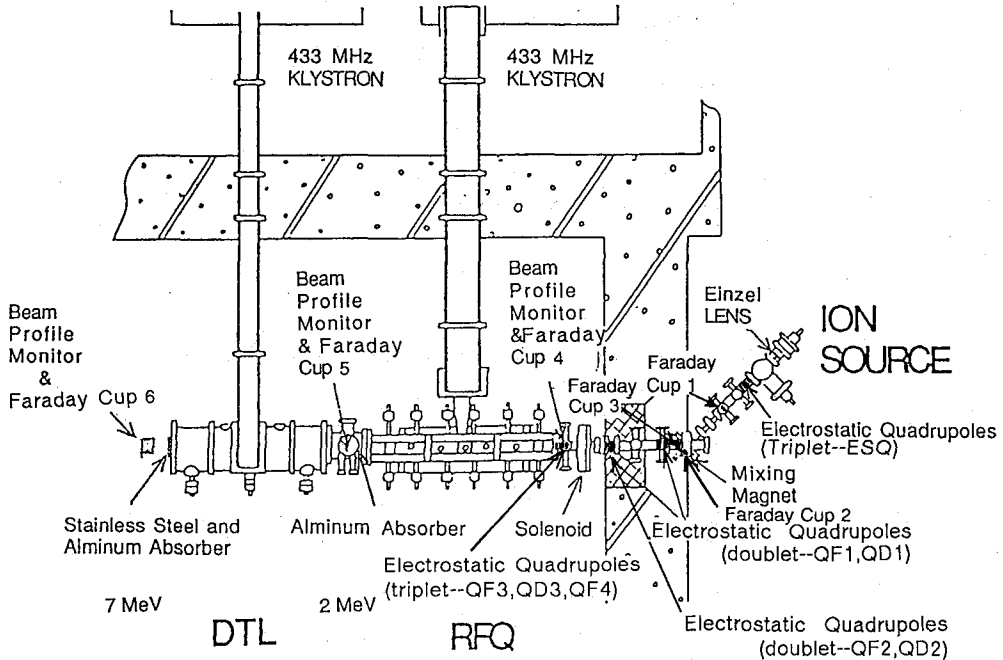

Fig. 4. Layout of the low energy beam transport (LEBT) constructed based on discrete focusing elements.

current by Faraday Cup 4 in front of the RFQ is shown. The signal of the accelerated beam by the RFQ observed by Faraday Cup 5 is also shown in Fig. 3(c). The duration of the accelerated beam is 50 μ sec the same as the one of the RF for the linac and its timing is set rather close to the end of the duration of ion-source arc in order to use the well stabilized beam for acceleration. The transmission of the H^+ through the RFQ linac is 74 % at lower beam current and is reduced to 60% at ~ 1 mA, which is considered to be due to incomplete phase space matching in transverse direction mentioned above and is to be improved by the insertion of the final triplet. By such insertion, β -functions in horizontal and vertical directions are expected to be modified as indicated by black and open triangles in Fig. 5, respectively and complete transverse matching is expected.

4. SUMMARY AND FUTURE DEVELOPMENT

From the ion source, H^+ of the intensity of 3 mA has been extracted, which is reduced to 1.2 mA after mixing magnet due to strong space charge repulsion. The transmission up to 74% has been attained by the RFQ linac which is expected to be raised more than 90% by making complete matching in transverse phase spaces for the present current level (~ 1 mA). As the present system of ion optics in LEBT is designed considering the lower beam current with no space charge effects for the moment, it is found that additional particular cure for beam blow up due to the space charge is needed in order to transport the beam with much higher intensity (more than 10 mA). As the cure for the space charge effects, the following items are considered,

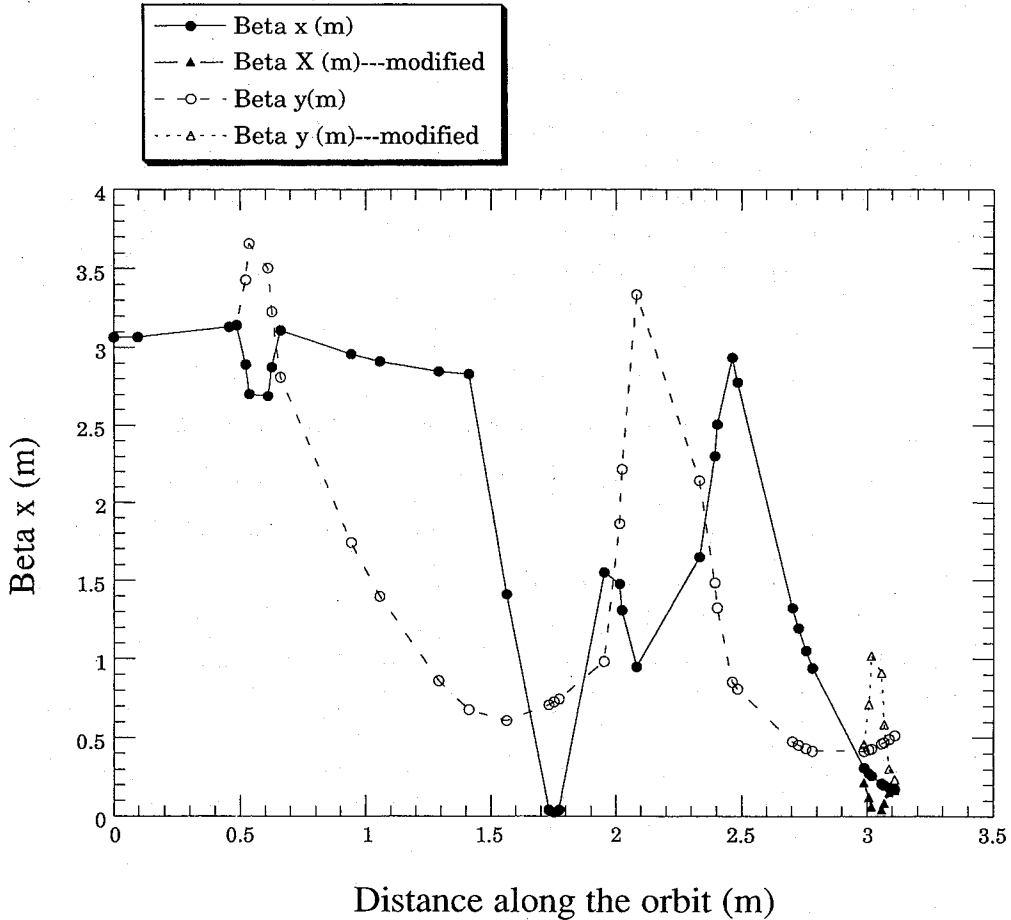

Fig. 5. β -functions calculated for the present LEBT. Black and open circles represent β -functions in horizontal and vertical directions, respectively. Black and open triangles show modified β -functions in horizontal and vertical directions, respectively, when final triplet of electrostatic quadrupoles is installed.

- (1) beam neutralization,⁵⁾
 - (2) continuous focusing system utilizing periodic FODO cells⁶⁾ of electrostatic quadrupole lenses,
 - (3) radiofrequency quadrupole focusing with straight vane (i.e. without modulation)⁷⁾
- and
- (4) helical electrostatic quadrupole.⁸⁾

However, fabrication of real apparatus for (3) and (4) needs rather large amount of budget and (1) is not applicable without replacement of electrostatic quadrupoles by magnetic ones. So the direction of the modification in a near term is to change the present system to accept much higher current by realizing much smoother optics with periodic cells of item (2) which is expected to be less sensitive to the space charge blow up.

In order to increase the fraction of H^+ beam in the extracted current, arc current is to be increased much more and confinement of the plasma is to be improved by adjustment of the

magnetic cusp field.

5. ACKNOWLEDGMENT

The new power supply of the ion source was fabricated by Tokyo Denshi Co. Ltd.. The authors would like to present their thanks to the company for technical support for this work. Their thanks are especially due to Mr. T. Asaka for his efforts at the stage of tuning the power supply. The work presented here was not be completed without the support of Mr. I. Kazama at Institute for Chemical Research and the authors would like to present their heartfelt thanks to him.

REFERENCES

- (1) A. Noda et al., "Improvement of the Proton Accelerator System", *Bull. Inst. Chem. Res. Kyoto Univ.*, **70**, 37 (1992).
- (2) Y. Iwashita et al., "Operating Characteristics of the ICR Proton Linac", *Proc. of 1992 Linear Accel. Conf., Ottawa, Canada*, 624(1992).
- (3) M. Inoue et al., "Commssioning of the 7 MeV proton linac at ICR Kyoto University", to be published in *Bull. Inst. Chem. Res. Kyoto Univ.*, **71**, 57 (1993).
- (4) T. Shirai et al., "Study of Beam Profile Monitor for the Proton Linac", to be published in *Bull. Inst. Chem. Res. Kyoto Univ.*, **71**, 15 (1993).
- (5) S. Humphries, Jr., *Charged Particle Beams*, John Wiley & Sons, Inc., 501 (1990).
- (6) I. Hofmann et al., "Stability of the Kapchinskij-Vladimirskij (K-V) Distribution in Long Periodic Transport Systems", *Particle Accelerators*, **13**, 145 (1983).
- (7) D. A. Swenson et al., "RFQ Lens for Low Energy Ion Beam Focusing", *Proc. of 1992 Linear Accel. Conf., Albuquerque*, 39 (1990).
- (8) D. Raparia, "Beam Dynamics of the Low Energy Beam Transport and Radio Frequency Quadrupole", A Dissertation presented to the Faculty of the Department of Physics University of Houston (1990).