

新 制
理
3 74
京大附函

GEOMAGNETIC SECULAR VARIATION ANOMALIES IN RELATION TO
THE RECENT CRUSTAL MOVEMENT IN THE SOUTHWESTERN
REGION OF JAPAN

NORHIKO SUMITOMO

主論文
新 註
理
374
京大附図

GEOMAGNETIC SECULAR VARIATION ANOMALIES IN RELATION TO
THE RECENT CRUSTAL MOVEMENT IN THE SOUTHWESTERN
REGION OF JAPAN .

NORIIHIKO SUMITOMO

Abstract

The tectonomagnetism in the southwestern region of Japan has been studied through the analysis of the geomagnetic data of two surveys carried out with an interval of about 8 years. From over 100 sites, the local secular variations in the total magnetic field have been examined. A characteristic pattern of the arrangement of anomalies of the secular variation has been revealed; a distinction between zones of the relatively positive and relatively negative anomalies is fairly clear in almost all of the region surveyed. Especially, in the Chugoku-Kinki District it was noticed that the positive and negative anomalies were alternately arranged in the east-west direction in which the tectonic force has prevailed. The arrangement of the anomalies was also closely correlated to a feature of the recent crustal movement derived from analyses of the geodetic data.

Some interpretations of these local anomalies have been made on the basis of the piezomagnetic effect. It can be concluded that the anomalies are probably caused by some inhomogeneous stress changes in the upper layer of the earth's crust and that these stress changes have temporarily been induced in the folded layer by the horizontal compression related to the tectonic forces which have effected the upper crust in the region since about one million years ago.

1. Introduction

Tectonomagnetic studies of local changes in the geomagnetic field relating to tectonic activities within the earth's crust are currently being made in many regions of the world. Of these local changes, the seismomagnetic and volcanomagnetic changes have aroused particular interest in an effort to predict earthquake occurrences and volcanic eruptions. Field experiments or observations of the magnetic field have been intensively carried out in many countries in order to detect precursory changes (for example, Tazima et al.¹⁾, Johnston²⁾, Shapiro et al.³⁾, Sasai and Ishikawa⁴⁾, Yukutake et al.⁵⁾, Davis et al.⁶⁾).

One of the physical interpretations of such tectonomagnetic changes is chiefly based upon the piezomagnetic effect. This has been studied by many researchers on one hand in theoretical and experimental approaches (for example, Kern⁷⁾, Ohnaka and Kinoshita⁸⁾, Nagata⁹⁾, Stacey and Johnston¹⁰⁾). On the other hand, Nagata^{11,12)} interpreted the anomalous magnetic changes associated with the Nankaido and Niigata earthquakes as probably being attributable to the piezomagnetic effect. Johnston²⁾ also tried to estimate stress accumulation around the San Andreas fault based upon both the piezomagnetic effect and changes observed in the local magnetic field around the fault. There are several studies evaluating the expected amount of the seismomagnetic change due to the piezomagnetic effect. Yukutake

and Tachinaka¹³⁾ calculated the expected change of the magnetic field caused by a hypothetical stress distribution around a hypocentre. Shamsi and Stacey¹⁴⁾ also evaluated the seismomagnetic changes by using a dislocation model. According to these evaluations, it has been suggested that the expected seismomagnetic change might in general be a very small amount ranging perhaps from a few to ten nT at most even for a major earthquake of a magnitude greater than 7. Though remarkable improvements in the magnetometer have recently allowed us to easily measure the magnetic field to a high degree of precision, in particular, the total magnetic field, it is still extremely difficult to detect small amounts of precursory changes with sufficient reliability, because the magnetic field almost always varies with time due to ionospheric and magnetospheric disturbances. Such field fluctuations usually range from several tens nT to more than one hundred nT. In addition, the fluctuations often differ from place to place because of the electric conductivity anomaly(CA). Several techniques for noise reduction were proposed by Rikitake¹⁵⁾, Beahn¹⁶⁾, Ware and Bender¹⁷⁾ and others. These techniques have become largely reliable in detecting short term changes from a matter of hours to a few days duration.

However, as long term changes are most likely associated with major earthquakes, it is necessary to be able to distinguish long term changes from the normal secular variation. This requires a detailed

reference field for the normal secular variation, sufficient to cover the area being surveyed. It should be noted that the secular variation is not stationary with time but sometimes shows a strong regional dependence even for a narrow region such as that of Japan. This non-uniformity of the secular variation in time and space over Japan in recent years was studied in a previous paper(Sumitomo¹⁸). The regional dependence of the secular variation should be taken into consideration in discussing long term changes in the magnetic field.

It is also suggested that there may exist a more localized anomaly of the secular variation but perhaps with less relationship to a particular earthquake. Several types of local changes most likely associated with variations in tectonic stress have recently been found(Skovorodkin et al.¹⁹), Shapiro et al.^{3,20}). It should be noted that Mundt²¹) pointed out that geomagnetic secular variation anomalies in the GDR were closely correlated to recently noticeable vertical and horizontal movements of the earth's crust.

Previously, we also found some remarkable anomalies of the secular variation in the western part of the Sanin district in Japan(Sumitomo²²). Judging from both the anomaly pattern and the tectonic structure of the region, we suggested that the anomaly might relate to the recent crustal movement.

To confirm the validity of this idea, we carried

out magnetic surveys covering a large part of the southwestern region of Japan. We measured the total magnetic field at more than 100 magnetic stations which were set up by the Geographical Survey Institute (G.S.I.) of Japan. The G.S.I. has repeatedly carried out first order magnetic surveys at the rate of once every 1 to 2 years at about 100 magnetic stations located throughout Japan and also the second order magnetic surveys at a rate of once per about 10 years at approximately 900 magnetic stations.

In this paper, we will examine a special feature of the secular variation anomaly in the total magnetic field in the southwestern region of Japan by using both the data observed by us (1971-1973) and those observed by the G.S.I.(1964-1966)^{23,24}. The latter data consist of those from the first order and the second order magnetic surveys. We chiefly used the data from the second order in the present study, because an areal density of the second order is as high as about one per 20 sq.km although it is considered that the accuracy of the data from the second order magnetic survey is less than that of the first order. Accuracies of the data reduction will be discussed in Section 3. The local anomalies of the secular variation will be interpreted on the basis of the piezomagnetic effect in Section 5. A tentative estimation of stress change within the upper crust will also be mentioned in Section 5.

2. Observations

2.1 Preliminary observations

Before execution of the present surveys, we made some preliminary observations of the total magnetic field from several sites located within the region with which we were concerned. The first purpose of these observations was to examine local features of the various kinds of magnetic fluctuations with time in order to find what method of data reduction was most suitable. It is well known that magnetic fluctuations are usually different in their form from place to place because the induced magnetic field depends largely upon the electric conductivity structure beneath the earth's surface and that fluctuations observed near seaside stations are seriously influenced by electric current induced in sea. It is, therefore, important to know the local features of magnetic fluctuation in surveying a region in order to obtain as high an accuracy of the data reduction as possible. The second purpose of the preliminary observations was to evaluate the accuracy of the data previously surveyed in the region by the G.S.I.. This will be discussed in the following Section.

Locations of the preliminary observation sites are shown in Fig. 1. as marked by MTE, HMD,, together with all the present survey stations. The preliminary observations at each site were made by using a proton precession magnetometer at the sampling

rate of one per minute during a period of 20 to 30 days. During the same period, another proton precession magnetometer was synchronously operated at the Tottori Microearthquake Observatory(TOT), which had been utilised as our reference station for the present investigation. By comparing the data obtained at the temporary sites with those at TOT, the following was concluded.

A short period variation such as the Bay type variation and the Pc 4-5 variation was appreciably different in form from place to place; amplitudes of such variations in inland areas were appreciably larger, up to ten percent larger, than those in coastal areas facing the Japan Sea, particularly in variations with periods shorter than about ten minutes. On the other hand, phases of the diurnal variation, Sq, in the inland areas tended to shift slightly, by as much as ten minutes, compared to those in the coastal areas. These local differences in transient variations are possibly caused partly by the existence of the CA which is probably attributed to the shallowness of a highly conductive layer beneath the Japan Sea(Rikitake²⁵) and partly by some influence of electric currents induced in the Japan Sea(the coastal effect). The CA problem in this region was investigated in a previous paper(Sumitomo²⁶).

In spite of these local differences appearing in transient variations, it was concluded that data reduction can be made within an error factor of approxi-

mately 1-2 nT by the usual simple difference method if successive measurements are made at one minute intervals with a duration longer than 20 minutes for any hour after 15 o'clock(local time). This accuracy is sure over almost all the areas covering the Chugoku-Kinki District except for the Shikoku District. In the latter, it was concluded that another reference station would be necessary at a central part of the Shikoku District in order to expect as high an accuracy of the data reduction as that obtained in the Chugoku-Kinki District. This is because the transient variations in the Shikoku region sometimes display significantly different forms than those at TOT. These differences result partly from the fact that the Shikoku region is about 100km south from TOT and partly because that region is surrounded by sea.

2.2 Present observations

There are about 250 magnetic stations set up by the G.S.I. for the first order and the second order magnetic surveys in the Chugoku-Kinki and Shikoku Districts. The distribution of these stations is about one per 20 sq.km. A marker of granite is set at each station. From the 250, about 120 magnetic stations were selected for the present surveys. Their locations are shown in Fig. 1. At almost all the magnetic stations the total magnetic field was measured from a height of 1.5m above the top of the markers by using a portable proton precession magnetometer

with a precision of 1 nT.

However, at approximately 20% of the stations, measurements had to be taken as near as possible to the presumed marker positions due to the facts that a number of markers had been moved or lost, as well as that some obstacle had been constructed nearby the station.

The method of observation was determined in consideration of the results obtained by the preliminary observations as described above. One measurement every minute during 20 to 30 minutes, as a rule, after 15 o'clock(local time) was made at each station. As for the Chugoku-Kinki District, data reduction to eliminate the transient variations from observed values was made by referring to TOT, where continuous observations were simultaneously made by using another proton precession magnetometer. As for the Shikoku District, data reduction was primarily done by referring to the temporary station set up in the Shikoku region where continuous observations were also made. When the survey was carried out in northern Shikoku, the temporary station was set up at Tokushima station(TKS), while in the case of the survey in southern Shikoku monitoring was carried out at Tosa station(TSA). The initially reduced data were further reduced by referring to TOT through the use of a mean value of the total field differences between the temporary station and TOT during the period surveyed.

3. Accuracy of the data reduction

3.1 Definition of 'the reduced value'

As described in the Introduction, we intend to examine the local secular variation by using both the data surveyed by us and those previously surveyed by the G.S.I. in the southwestern region of Japan. Since all the G.S.I. data were reduced by referring to the Kakioka Magnetic Observatory(KAK), which is the standard magnetic reference station in Japan, it was necessary for our data also to be reduced by the same Observatory in order to be compared with the G.S.I. data. According to the G.S.I., data reduction to remove transient variations is usually done by the following formula;

$$M_i^r(t) = M_i(t) + \overline{(M_K(t_0) - M_K(t))} \dots\dots(1)$$

where $M_i^r(t)$ is customarily called 'the reduced value' of any magnetic element, M, at 'i-th' station at time 't'. $M_i(t)$ and $\overline{M_K(t)}$ are observed values at 'i-th' station and KAK at time 't', respectively. $\overline{M_K(t_0)}$ denotes a certain epoch value of the element, M, at KAK at an epoch time 't₀'. If the transient variations included in both $M_i(t)$ and $\overline{M_K(t)}$ can be regarded as equal to each other, $M_i^r(t)$ becomes free from the transient variations. When the secular variations included in both $M_i(t)$ and $\overline{M_K(t)}$ are represented as $M_i^S(t)$ and $\overline{M_K^S(t)}$, respectively, Eq.(1) can be rewritten as

$$M_i^r(t) = M_i(t_0) + \overline{(M_i^S(t) - M_K^S(t))} \dots\dots(2)$$

where $M_i(t_0)$ is the epoch value of the element, M, at

'i-th' station.

If we get such reduced values as defined by either Eq. (1) or (2) at different times at 'i-th' station, we can determine the secular variation at 'i-th' station although it is relative to KAK. However, as mentioned above, the transient variations at any two places are not always identical but sometimes significantly differ from each other because the induced fields are often different from place to place owing to the existence of the CA. In general, parallelism in transient variations at any two places becomes more obscure as the spatial distance between them is increased, particularly in the north-south direction. This is because latitudinal dependence of both the Sq variation and the Dst variation becomes larger in this case. It is, therefore, necessary to examine the accuracies of the reduced values obtained by both ourselves and the G.S.I. in the regions concerned.

3.2 Accuracy of the G.S.I. reduced value

The G.S.I. magnetic data are classified into two categories such as those of the first order and the second order magnetic surveys. In the case of the first order magnetic survey, one measurement for each of the three components of the magnetic field is usually made at the rate of once an hour throughout most of the day with a precision of 1 nT. These measurements can give an approximate daily mean value for each component. On the other hand, in the case of the second order magnetic survey, only four time

samplings of each component are made between 16 and 17 o'clock(local time) with the same precision as that of the first order magnetic survey. In this case, only an hourly mean value can be provided for each component.

All the data thus obtained in both the first order and the second order magnetic surveys are then reduced by referring to KAK without any distinction between them. Because of the differences in observational methods between the first order and the second order magnetic surveys, accuracies of the data reduction are not equivalent. As for these accuracies, Tazima²⁷⁾ studied them in detail by using an abundance of reduced values obtained throughout the various areas in Japan. He concluded that the accuracies of the data reduction of the first order magnetic survey are better than ± 4 nT for H and Z components and $\pm 0.3-0.4'$ for D, while those of the second order magnetic survey are better than

$\pm 7-8$ nT for H and Z components and $\pm 0.6-0.8'$ for D.

Based upon the above values and using $F = H \cos I + Z \sin I$, we can estimate the accuracy of the data reduction of the total magnetic field to be approximately ± 4 nT and ± 8 nT for the first order and the second order magnetic surveys, respectively. Here, the magnetic inclination 'I' is assumed to average 45° in the above estimation. We can, however, not adopt these values for the present analyses because they are the averaged values over

the entire Japan region. In some places, the latitudinal and the longitudinal differences between the various sites and KAK may cause a large degree of reduction error. In other places, the existence of the CA may also make the reduction error greater. As discussed below, it seems likely that the data obtained in the region concerned fortunately have a lower degree of error in the data reductions. On the other hand, it should be noticed that Tazima's evaluation of the accuracy of the data reduction for the second order magnetic survey is derived from the data observed during an arbitrarily designated hour. This observational method had formerly been adopted by the G.S.I.. However, since 1964, the method has been improved by observations done within a set hour, such as from 16 to 17 o'clock(local time) in order to avoid influences of the S_q diurnal variation as much as possible. Therefore, the reduction error of the second order magnetic survey which was recently carried out may be even less than that evaluated by Tazima.

However, we need to make a more precise evaluation for the reduction error of the second order magnetic surveys performed in the region concerned, because the data used in the present analyses were chiefly those of the second order magnetic surveys although most of them had been carried out after 1964. By using the data taken from the preliminary observations described in Section 2, we examined day by day fluctuations

of the hourly mean differences of 16 o'clock(local time) in the total magnetic fields between the temporary sites and KAK. The standard deviations of the hourly mean differences during approximately 20 days at each site are listed in Table 1 together with those of the total magnetic field differences between the temporary sites and TOT. The table also includes other results obtained at the Kamitakara(KMT) and Aso(ASO) stations for referential data, although they are situated outside the regions concerned; the former is about 300km westward from TOT and the latter about 300km eastward as shown in Fig. 1.

Judging from the above results, it is concluded that the data reduction of the second order magnetic survey might have an accuracy greater than 3-4 nT so far as the Chugoku-Kinki District is concerned. This degree of accuracy seems to be about twice than that evaluated by Tazima. One of the reasons for this discrepancy may result from the fact that Tazima's evaluation, as mentioned above, was based upon the data taken during an arbitrary hour, while our evaluation was done upon only the data taken between 16 and 17 o'clock. Another reason may arise from the fact that the latitudinal and the geomagnetically inclinational differences between the Chugoku-Kinki District and KAK are within only one degree or thereabout so that the Sq variation and the Dst variation are almost equivalent at both the Chugoku-Kinki District and KAK.

However, the degree of accuracy for the data reduction of the second order magnetic survey carried out in the Shikoku District can not be expected to be the same as that in the Chugoku-Kinki District because the region lies at a latitude several degrees lower than that of KAK. In addition, since the southern part of the Shikoku District faces the Pacific Ocean, the so-called coastal effect and the peninsular effect are significantly larger. Some of the reduced values might include to some extent reduction errors due to these effects if, for examples, the survey had been carried out on a disturbed day. According to our preliminary observations, it can be inferred that the accuracy of the data reduction in the Shikoku District might be lower than 5-6 nT.

3.3 Accuracy of our reduced values

First, let us consider the reduction of the presently observed data by direct reference to KAK. The reduced value of the total magnetic field, $F_i^R(t)$, at 'i-th' station will be written as shown below,

$$\begin{aligned} F_i^R(t) &= F_i(t) + (F_K(t_0) - F_K(t)) \\ &= F_i(t_0) + (F_i^S(t) - F_K^S(t)) + (F_i^d(t) - F_K^d(t)) \end{aligned}$$

where $F_i^d(t)$ and $F_K^d(t)$ are the transient variations due to magnetic disturbances included in the observed values at 'i-th' station and KAK, respectively. Other subscripts and superscripts of F used in this Section denote the same as defined in Section 3.1. As the distance between 'i-th' station and KAK is further than 500km, the third term of the right-hand side of

Eq. (3) may no longer be zero. This implies that $F_i^r(t)$ may include some errors in the data reduction. To reduce these errors, we improve the method of data reduction as follows;

$$F_i^r(t) = (F_i(t) - F_T(t)) + \bar{F}_T^r(t) \dots \dots (4)$$

where $\bar{F}_T^r(t)$ and $F_T(t)$ are the monthly mean value of daily reduced values and the observed value of the total magnetic field at TOT, respectively. Since the continuous observations of the total magnetic field have been carried out at TOT since 1968, the monthly mean value of the reduced value can be easily obtained with an accuracy greater than 1 nT (Sumitomo²⁸). This monthly mean value can be regarded as being nearly free from the transient variations of durations shorter than one month. Thus, $\bar{F}_T^r(t)$ can be written as

$$\bar{F}_T^r(t) = F_T(t_0) + (F_T^S(t) - F_K^S(t)) \dots \dots (5)$$

where $F_T(t_0)$ and $F_T^S(t)$ are a certain epoch value of F and the secular term included in the observed value $F_T(t)$ at TOT. On the other hand, since it has been made clear that the transient variations of durations shorter than one hour at any station are nearly equal to that at TOT, $(F_i(t) - F_T(t))$ can be represented by

$$F_i(t) - F_T(t) = (F_i(t_0) - F_T(t_0)) + (F_i^S(t) - F_T^S(t)) \dots (6)$$

We find from Eqs. (4),(5) and (6),

$$F_i^r(t) = F_i(t_0) + (F_i^S(t) - F_K^S(t)) \dots \dots (7)$$

Thus, $F_i^r(t)$ defined by Eq. (4) can be regarded as being nearly free from any transient variation. The amount of scatter in values of $(F_i(t) - F_T(t))$ at almost all the field stations was 1-2 nT. As the value of

$\bar{F}_T^r(t)$ is determined within an accuracy of 1 nT , it can be said that the overall accuracy of the reduced value thus obtained in the present survey is better than 2 nT as far as the Chugoku-Kinki District is concerned. However, in the Shikoku District, even if the same procedure of data reduction is adopted, the accuracy of the reduced value may be lower than 3 nT although the sub-reference stations were set up at TKS and TSA. This reason arises largely from the fact that some influence due to the CA in the Shikoku District could not be completely avoided in the present method of data reduction. A diagram showing the accuracies of the data reduction of the present survey and those of the G.S.I. is illustrated in Fig.2.

4. Secular variation anomalies

4.1 Calculation of secular variations

Now we have two sets of reduced values obtained by the present surveys and by the G.S.I. at different times. A simple difference between the reduced values of the two different times for each magnetic station provides the total secular variation during the period of the two surveys, although it is relative to KAK. However, since the times as well as the intervals surveyed are slightly different from station to station, the total secular variation is inadequate to discuss details of the secular variation anomaly. Consequently, we need to convert the total secular variation into an annual rate of the secular variation. The annual

rate can be simply calculated by dividing the total secular variation by the time interval between the two surveys if the trend of the secular variations can be regarded as being approximately linear with time during the interval concerned. If, however, the trend is not linear but for instance, quadratic with time, then the calculated annual rate means only a gradient of the variation at an intermediate time of the interval, so that the annual rate is no longer useful to discuss the secular variation anomaly, strictly speaking, because of differences in the intermediate time from station to station.

It is, therefore, necessary to examine the general trend of the secular variations in Japan during the interval concerned. Fig. 3 shows the secular variations of the total magnetic field during the period from 1964 to 1975 observed at the Memambetsu(MMB), Kakioka(KAK), Simosato(SSO) and Kanoya(KNY) Magnetic Observatories in Japan. In Fig. 3, annual mean values of the total magnetic field of all the quiet days, which are specified by an international criterion, are plotted for each observatory.

The general trend of the secular variations at each observatory appears fairly to resemble each other fairly well although the acceleration of the secular variation at the northern observatory is somewhat larger than that at the southern observatory. Judging from Fig. 3, it can be regarded that the trend of the secular

variations was approximately linear with time during the period from 1964 to 1973 over the Japan region. Accordingly, in the present study we use the annual change of the secular variation at each station as represented by the following equation,

$$\dot{F}_i^r(t) = \frac{F_i^r(t_2) - F_i^r(t_1)}{t_2 - t_1} = \dot{F}_i^s(t) - \dot{F}_K^s(t) \dots \dots \dots (8)$$

where $\dot{F}_i^s(t)$ and $\dot{F}_K^s(t)$ are derivatives of the secular term of F at 'i-th' and K , respectively. Although the calculated annual change of the secular variation, $\dot{F}_i^r(t)$, includes the annual change of the secular variation at K , $\dot{F}_K^s(t)$, in what follows we deal with the $\dot{F}_i^r(t)$ as the specific secular variation for each station and simply call it the secular variation. This treatment will not give any confusion to the following discussions because we simply discuss the relative anomaly in the region concerned.

4.2 Normal secular variation

As can obviously be seen in Fig. 3, the general trend of the secular variations in the total magnetic field seems quite common throughout the whole region of Japan. A minimum value of the total field appears during the period from 1973 to 1975 at every observatory. It is considered that this general variation probably originates in the local motion of the electro-magnetic fluid within the earth's core although some external fields may be included. A general variation, such as this, is referred to as the normal or the regional secular variation. However, when we see a more detailed feature of this normal secular variation, it is noted

that the normal secular variation is never uniform in time and space even for a narrow region as that of Japan. The minimum phase of the secular variation at the southern observatory appears to be about one year ahead of that at the northern observatory, while the acceleration of the secular variation at the latter is slightly greater than that at the former.

The isoporic charts shown in Fig. 4, represent geographical distributions of the normal secular variations at the three recent epochs in Japan. These were derived from analyzing the data obtained at the 11 magnetic observatories and the 43 magnetic stations for the first order magnetic surveys during the period from 1968 to 1975 (Sumitomo, ¹⁸⁾). The non-uniformity of the secular variation in time and space can be clearly seen here. The reason for this non-uniformity is not well known at present although it has been suggested that the cause probably lies within the earth's core.

The first survey was carried out from 1964 to 1966 and the second survey from 1971 to 1973. The intermediate time of the periods in which the two surveys were carried out is nearly 1969. It is, therefore, necessary to have a detailed distribution of the normal secular variation for the period of 1969 in the regions concerned in order to detect local anomalies from the observed secular variations. It seems possible to draw an isoporic chart for 1969 by extrapolating information from the isoporic chart for 1970 as shown

in Fig. 4. However, such an isoporic chart may be too general to be used in the present analyses because the expected anomalies may have been relatively minor.

In the present study, a more practical method is introduced to distinguish small amounts of local anomalies from the observed secular variations which have been standardized in term of the annual rate of change as described in the previous Section. We assume that the distribution of the normal secular variation in the region can be approximately expressed as a linear function of both latitude and longitude, and that fluctuations consisting of both the local anomalies and the reduction errors are regarded as being random from a statistical point of view. We then express the normal secular variation, $F_n^S(\psi, \lambda)$, at a point of latitude ψ and longitude λ by the following equation;

$$F_n^S(\psi, \lambda) = a\psi + b\lambda + c \dots\dots\dots(9)$$

On the basis of the usual least squares method, we can determine the coefficients of a, b and c in Eq. (9) from the observed secular variations, $\dot{F}_i^r(t)$. Determinations of these coefficients are made independently for the Chugoku-Kinki District and the Shikoku District, respectively. Results are as follows;

$$F_n^S(\psi, \lambda) = -0.71(\psi - 35.5^\circ) + 0.33(\lambda - 134.0^\circ) - 1.93 \text{ (nT/yr)}$$

(for the Chugoku-Kinki District)

\dots\dots\dots(10)

$$F_n^S(\psi, \lambda) = -1.16(\psi - 33.5^\circ) + 0.23(\lambda - 133.5^\circ) - 0.04 \text{ (nT/yr)}$$

(for the Shikoku District)

\dots\dots\dots(11)

The equations thus determined for each district are referred to as the normal secular variation at the approximately intermediate time, 1969, of the period analyzed. The distribution of the normal secular variations for each district is indicated with broken lines in Fig. 5, together with the observed secular variations at each station of the Chugoku-Kinki District and the Shikoku District. The regional trend of the normal secular variation seems to be consistent with the trend inferred from extrapolation of the isoporic chart for 1970 shown in Fig. 4. This suggests that the data of the second order magnetic survey are sufficiently useful for a study of the secular variation anomaly so far as the Chugoku-Kinki and the Shikoku Districts are concerned, although it is considered that the data of the second order magnetic survey are less reliable than those of the first order magnetic one because the former provides only the hourly mean value.

4.3 Local anomalies of the secular variation

The local anomaly of each station is obtained by subtracting the calculated normal secular variation from the observed secular variations. The anomalies thus obtained are shown in Fig. 6 together with contour intervals of 1 nT/yr unit; solid contours denote the relatively positive anomalies, while dotted ones the relatively negative anomalies. Too large anomalies greater than ± 5 nT/yr are excluded from this figure

because they were considered to be possibly caused by some artificial disturbances. Accuracies in magnitude ratings of the anomalies are derived from the followings. The accuracy designations for the data reduction shall be ϵ_{11} and ϵ_1 for the present survey and the G.S.I. survey, respectively. Then the accuracy of the secular variation is calculated from $\sqrt{\epsilon_1^2 + \epsilon_{11}^2} / \Delta T$, where ΔT is the time interval between the two surveys and it is nearly 8 years. ϵ_1 and ϵ_{11} are given from the discussions in Section 3 as shown in Table 2.

Consequently, the accuracies in magnitude ratings of the anomalies are estimated to be better than 0.5nT/yr and 0.8nT/yr for the Chugoku-Kinki District and the Shikoku District, respectively.

As is evident from Fig. 6, it is worthy to note that distinguishable anomalies appear almost all over the areas surveyed, distributed in a fairly systematical pattern, especially in the Chugoku-Kinki District; zones of the positive anomalies and those of the negative anomalies(shaded) are clearly distinguishable. They seem to be arranged with alternate signs from east to west, particularly in the Sanin area facing the Japan Sea. One feature of these anomalies shows a tendency to run in the north-south or northeast-southwest direction, having a spatial wavelength of about 80km in the Sanin area and a somewhat shorter wavelength

in the Kinki District. The standard deviations of the mean values of these anomalies are 1.3 nT/yr and 1.1 nT/yr for the Chugoku-Kinki and the Shikoku Districts, respectively. These values seem to exceed the limit of expected errors, 0.5 nT/yr and 0.8 nT/yr in both districts, respectively. The standard deviations may consist of fluctuations due to true anomalies and due to the reduction errors. If they are independent of each other, the average true anomalies are estimated to be 1.2 nT/yr and 0.8 nT/yr for the Chugoku-Kinki and the Shikoku Districts, respectively. They are calculated from

$$\sigma_t^2 = \sigma_o^2 - \sigma_e^2 \dots\dots\dots(12)$$

where σ_o , σ_t and σ_e are the standard deviations of the observed anomalies, the true anomalies and the reduction errors, respectively. It may be said, however, that the true anomalies estimated in the Shikoku District are not as precise as those in the Chugoku-Kinki District because of the poor accuracy of the data used, although a meaningful contrast is clear between zones of the positive and the negative anomalies.

4.4 Anomaly continuation during recent decades

On June 4, 1978, an earthquake with a magnitude of 6.1 occurred around the Sanbe mountain in the north-western part of Chugoku District. About 7 years passed since 1971 when we had previously carried out a magnetic survey around the same area. About one month after the earthquake occurred, we again surveyed the northwestern

part of Chugoku District, including the epicentral area, from 22 magnetic stations. The distance from the nearest magnetic station to the epicenter was nearly 5 km. No appreciable seismomagnetic effect could be found. However, it can not be ascertained whether any seismomagnetic effect followed or whether the effect was so small that it rapidly disappeared because we did not carry out a survey just before the earthquake occurred and because one month had passed before the resurvey was carried out.

We, however, revealed an interesting fact. The characteristic pattern of the secular variation anomalies previously observed had existed around the resurveyed region; the arrangement of the relatively positive and the relatively negative anomalies was almost the same as that found 7 years earlier. This result is shown in Fig. 7. The data reduction was made by means of the same procedure as described in Section 3. Judging from this result we can ascertain that the local anomalies of the secular variations have been continuing at a nearly constant rate during at least the last two decades with a nearly invariable pattern as far as the Sanin area is concerned.

In conclusion, it is pointed out that the observed secular variation anomalies have been fairly consistent during recent decades over the region concerned. This strongly suggests that they are probably not related

to any particular earthquake but are closely related to a tectonic force prevailing in the broad areas concerned. This will be discussed soon after in the following Section.

5. Interpretation and discussion

5.1 Possible causes of the local anomalies

What does the characteristic pattern of the local anomalies suggest? What are those anomalies caused by? It does not seem unlikely that the anomalies may result from non-local sources broadly existing over the upper part of the earth's crust in the region, because the anomalies seem to be evenly distributed over the broad area, particularly in the Chugoku-Kinki District.

Several causes that may be accountable for these anomalies can be considered: thermal origins, geological structures, earth currents, tectonic forces and others. Let us first consider the possibility that the anomalies may be caused by partial changes in the magnetization of the earth's crust due to thermal variations. If the Curie isotherm at a certain depth within the crust moves upward or downward during a period of time, some portion of the crust which includes some magnetized rocks such as magnetite will become demagnetized or further magnetized. However, according to Tazima²⁷⁾, a temperature change in the crust necessary to produce the anomalous change in the magnetic field, say 1-2 nT/yr, requires about 20-30 meters upheaval or subsidence of the Curie isotherm

per year. It seems quite difficult to expect such a rapid movement of the Curie isotherm because of the very low heat conductivity of the crustal rock in general. Therefore, without any special condition to produce such a rapid heat flow in the crust, the observed anomalies of the secular variation can not be explained from the Curie isotherm movement within the crust. Furthermore, we can not find any particular reason for the Curie isotherm to fluctuate spatially with a wavelength of about 80 km as seen in the arrangement of the secular variation anomalies in the Chugoku-Kinki District. An arrangement of volcanoes with an interval corresponding appropriately to the wavelength of the anomalies may be able to produce the spatial fluctuations of the isotherm. However, there exist only a few volcanoes of the Quaternary age in the Chugoku-Kinki District. Moreover, they are quite inactive at present. Therefore, we concluded that the observed anomalies do not arise from thermal sources.

Secondly, let us look at the geological features of the region concerned. Fig. 8 shows a brief map of the surface geology in the region. In most of the areas observed in the Chugoku region, belonging to the Sangun belt, abundant granitic rocks and andesitic rocks are widely distributed. These are associated with the igneous activity for the Cretaceous to Paleogene time interval. First was the eruption of andesite to rhyolite in the Sangun belt. Then, granite to granodiorite

intrusions of batholithic dimension occurred. In the Sanin area, belonging to the "Green tuff" region, some diorite, gabbro, and mafic rocks can be scatteringly found. They are associated with vigorous volcanism in the Middle Miocene. On the other hand, the central Kinki region, belonging to the Tamba belt, is occupied by sedimentary rocks of late Paleozoic and of Triassic age. Igneous rock is very scarce in contrast to the Chugoku region.

The Shikoku District is located in the outer zone of Southwest Japan. The region consists of several geotectonic units such as Sambagawa, Chichibu and Shimant belts. They include sediments and sedimentary rocks although some are strongly metamorphosed. Their formation took place during a period from the late Paleozoic to the Middle Miocene. Volcanic or igneous rocks are very scarce in most of the region except for a number of sites. However, in the northern part of the region beyond the Median Tectonic Line, some acidic rocks, which are similar to those seen in the Chugoku region, can be found.

The most characteristic feature of the geological activity in the Chugoku, Kinki and Shikoku Districts is that there are no active volcanoes at present. This is in clear contrast to features of the central and the northeastern regions of Japan.

Judging from these geological conditions in the southwestern region of Japan, it was concluded that

a particularly meaningful correlation between the local anomalies of the secular variations observed and the geological structures in the region can not be recognized.

Our third point of interest concerns the possibility that some earth current flowing beneath the earth's surface may account for our problems. We suppose that some amounts of the earth current have been flowing along, for example, topographically subsiding zones with different directions in each zone; one is from north to south and another is from south to north. Then, if such current intensities are variable with time, they may produce increasing or decreasing changes of the magnetic field observable on the earth's surface. It seems, however, almost impossible to assume that the secular variation anomalies are influenced by the earth current because at present we know of no such mechanism or evidence of the existence of such currents constantly flowing beneath the earth's surface. Recently, Mizutani and Ishido²⁹⁾ studied the electro kinetic effects and suggested that anomalous changes of the total magnetic field associated with the Matsushiro earthquake swarm were attributed to electro kinetic influences. These influences remain to be considered as a possible cause of our problems.

Finally, we will discuss the possibility of applying the piezomagnetic effect to our problems in the following Section.

5.2 Piezomagnetic modelling

The piezomagnetic effect (hereafter abbreviated by PME) is well understood as a reversal phenomenon of the magnetostriction effect which is characteristic in the Ferro-magnetic materials. The PME of certain igneous and volcanic rocks is currently being studied by many researchers as mentioned in the Introduction. According to their investigations, so far, it is summarized that when the igneous or volcanic rock is uniaxially compressed in a direction in which the rock is magnetized, both the magnetic susceptibility and the hard remanent magnetization decrease to a certain degree proportional to the applied stress.

On the other hand, the process completely reverses when the rock is extended in the same direction. These effects are almost exactly reversible.

The magnetization of igneous and volcanic rocks essentially consists of the induced and the remanent magnetization. These magnetizations of the rock indicate the same PME under compressional or extensional stress although the stress sensitivity of each of them is somewhat different. In what follows, therefore, we shall treat only the total magnetization of the rock without any distinction between the induced and the remanent magnetization.

It is important first to see the general trend of the tectonic stress field in the region concerned before we apply the PME to interpret the observed

local anomalies of the secular variation. It is well known that the earth's crust in the southwestern region of Japan has been subjected to a horizontal compression in a basically east-west direction. It is considered that this compression relates to the motion of the Pacific Ocean plate. Ichikawa³⁰⁾ studied mechanisms of large and moderate earthquakes which occurred in the southwestern region of Japan and pointed out that horizontal directions of the maximum pressure axis for each of the earthquakes run in a general east-west direction as shown in Fig. 9. Also, Hashizume³¹⁾ and Nishida³²⁾ showed that mechanisms of small and micro-earthquakes, which very often occurred at depths of nearly 10 km in the Chugoku-Kinki District, are quite similar to those of large and moderate earthquakes studied by Ichikawa. It was also confirmed by Nakane³³⁾ that the principal stress fields revealed from analyses of the data of the geodetic measurements are quite consistent with the results derived from the seismological investigations.

In viewing a further long time interval, Huzita³⁴⁾ suggested from his neotectonic study in the southwestern region of Japan that the east-west compression has horizontally acted upon the upper crust of the region since at least one million years ago. He concluded that this compression resulted in the formation of foundation foldings and block movements of the upper crust associated with fault motions which are still

continuing in the region at present. He constructed a scheme showing a distribution of axes of the foldings in the region as shown in Fig. 10.

Judging from the investigations described above, it can be safely asserted that the upper crust in the southwestern region of Japan has almost always been subjected to the general east-west horizontal compression over broad areas. If such a compressional stress happens to change with time, some change in the magnetization of the crustal rock may be expected on the basis of the PME. Two possible cases to explain the observed anomalies can be considered; one case is that a laterally uniform change of the stress field produces heterogeneous anomalies of the secular variation because of a lateral heterogeneity in the magnetization of the crust. Another case is that a laterally heterogeneous change of the stress field yields heterogeneous anomalies of the secular variation even in a uniformly magnetized layer. The first case seems to be of no concern to us, because any characteristic pattern of the geomagnetic main field anomaly corresponding to that of the secular variation anomalies can not be found in the southwestern region of Japan. Fig. 11 indicates a schematic chart of the main field anomalies of the total magnetic field. This was derived from an analysis of the data obtained from both the first order and the second order magnetic surveys. Except for a small number of sites, local anomalies are not usually larger than 100-200 nT and

are not distributed in any particular pattern corresponding to that of the secular variation anomalies observed. If it is assumed that these anomalies arise from bodies locally magnetized in the direction of the present main field, then the secular variation anomalies arising from some change in magnetization due to tectonic stresses should be proportional to the main field anomalies. The secular variation anomalies versus the main field anomalies at each magnetic point are plotted in Fig. 12. There is evidently little correlation between them. Therefore, the possibility of a laterally uniform change of the stress field in the laterally heterogeneously magnetized layer should be rejected from our consideration.

The second case seems more probable. There is favourable evidence to show that the stress change within the upper crust is not laterally uniform. Kasahara and Sugimura³⁵⁾ analyzed the data of geodetic measurements (triangulation) which were carried out in 1883-1909 and in 1948-1958 by the G.S.I. in the southwestern region of Japan. They calculated the areal dilatation of the earth's surface as displayed in Fig. 13. It is quite distinct that outstanding crustal movements have recently occurred in the region. Especially as far as the Sanin area is concerned, the characteristic movement of the crust appearing on the dilatation map infers progress of the foundation folding; zones of the negative dilatation (subsidence zones) and the positive

dilatation (upheaval zones) seem to arrange alternately in the east-west direction. It seems that this laterally heterogeneous movement of the crust is closely similar to the distribution of the secular variation anomalies observed in the same region. Profiles of both the secular variation anomalies and the areal dilatation along a parallel of 35° north latitude are shown in Fig. 14. A relatively good correlation between the secular variation anomalies and the areal dilatation can be seen in the Sanin region but there is a poor correlation between them in the Kinki region. This may be due to the reason that a large amount of sediment lie in general on the foundation in the Kinki region. However, alternate arrangement in positive and negative anomalies of the secular variation and similar arrangement in positive and negative dilatation strongly suggest that the secular variation anomalies are probably produced by the heterogeneous stress fields within the upper crust as they change with time.

Here, we propose a model showing that a laterally heterogeneous stress field induced within the earth's crust can produce a laterally heterogeneous change in the magnetization of the crust on the basis of the PME. If such a change in the magnetization occurs, we could find some anomalous secular variations such as those observed on the earth's surface.

Consider a buckled or folded earth's surface, as shown in Fig. 15, which results from a continual

crustal movement since about one million years ago. By seeing the pattern of the observed anomalies, an axis of the fold is assumed to run in the north-south direction perpendicular to that of the horizontal compression which has been acting upon the upper crust. To simplify matters, consider a two-dimensional structure of the crust; deformation of the upper layer is assumed to be uniform in the north-south direction. The bottom of the layer is assumed to be flat although the exact form is unknown. In addition, we suppose that the upper part of the earth's crust down to nearly 20 km in depth is uniformly magnetized toward the north direction to which the present main field points in the crust. The crustal materials would be non-magnetized below a depth of 20 km or so because of high temperatures exceeding the Curie point of iron.

If, then, a horizontally compressional stress, σ_0 , in the east-west direction is initially applied to the folded or the buckled layer, an extensional stress which is superimposed on the initial stress field would be induced in and around the top part of the anticlinal zone, while some increments of the compressional stress would appear in and around the bottom part of the synclinal zone. The appearance of the additional stress was confirmed in a preliminary numerical experiment by means of the finite element method after Harrison³⁶⁾ who studied the topographic effects in the tidal tilt and strain measurements by

using the same method. We divide the folded layer into a number of elements as shown in Fig. 16 and calculate each strain within the elements when the layer is uniformly horizontally compressed by a certain amount of stress. The amount of stress applied is the same as that by which a uniform strain of a unit would be produced in the layer in the absence of the topographic undulation. A brief result of the numerical experiment is displayed in Fig. 16. The ratio of the strain induced in the folded layer to the strain which would be produced in a flat layer is indicated by smoothed contour lines. In the absence of topographical undulation this ratio would, of course, equal 1 everywhere. As can obviously be seen from the figure, amplification or reduction in deformation occurs in the layer; the strain in the synclinal zone is appreciably strengthened, while the strain in the anticlinal zone is in turn slightly attenuated, that is, regional compression causes local tension. These topographic effects would become larger as the topographic undulation is increased. This result is quite similar to those obtained by Harrison. From the above experiment, it is confirmed that the stress heterogeneity in the folded layer is possible and the results produce laterally heterogeneous changes in magnetization due to the PME in the layer.

Next, we examine changes in magnetization in the layer produced by the induced stresses. Referring to Stacey's³⁷⁾ designations, increments of each component of the total

magnetization, ΔJ_x , ΔJ_y , ΔJ_z , in a unit volume of the layer resulting from a certain amount of stress can be given as

$$\Delta J_x = \beta J_x^0 \left(-\Delta\sigma_x + \frac{\Delta\sigma_y + \Delta\sigma_z}{2} \right) \dots\dots\dots(13)$$

$$\Delta J_y = \beta J_y^0 \left(-\Delta\sigma_y + \frac{\Delta\sigma_x + \Delta\sigma_z}{2} \right) \dots\dots\dots(14)$$

$$\Delta J_z = \beta J_z^0 \left(-\Delta\sigma_z + \frac{\Delta\sigma_x + \Delta\sigma_y}{2} \right) \dots\dots\dots(15)$$

where $\Delta\sigma_x$, $\Delta\sigma_y$, and $\Delta\sigma_z$ denote the increments of each component of the stress field whose coordinate axes are taken as shown in Fig. 15 and their signs are defined as being positive in case of compression, J_x^0 , J_y^0 and J_z^0 are the initial values of each component of magnetization, and β is the stress sensitivity of magnetization of the crustal rock.

According to our numerical experiment concerning the induced strain in the layer, $\Delta\sigma_z$ was almost negligible everywhere. This is because only a part of the layer close to the free surface was considered. Since we assume the two-dimensional structure in which all the variations are uniform in the north-south direction, ΔJ_x will not contribute to any change in the total magnetic field. Furthermore, the contribution of ΔJ_y to the change in the total magnetic field is regarded as being practically negligible because the geomagnetic declination in the southwestern region of Japan does not usually exceed 7 degrees at most.

Accordingly, it is enough to consider the contribution of only ΔJ_z to the magnetic field change. Therefore,

Eq. (15) is rewritten as

$$\Delta J_z = \beta J_z^0 \left(\frac{\Delta \sigma_x + \Delta \sigma_y}{2} \right) \dots\dots\dots(16)$$

As we now consider only the additional stresses, it can be said that $\Delta \sigma_y$ is negative (extensional stress) in the upheaval zone, while $\Delta \sigma_y$ is positive (compressional stress) in the subsidence zone. On the other hand, $\Delta \sigma_x$ is negative everywhere. Finally, it is deduced that ΔJ_z becomes negative in the upheaval zone and results in a decrease of the total magnetic field, while ΔJ_z becomes positive in the subsidence zone, producing either positive anomalies or no anomalies. In Section 3, we introduced Eqs. (10) and (11) which express the normal secular variation for the region concerned. As these equations represent the relative values, not the absolute ones, of the secular variation, the calculated anomalies can be regarded as being essentially relative. Considering this and the expected anomalies based upon the PME in our model discussed above, it can be concluded that the decrease of the total magnetic field in the upheaval zone and the increase in the subsidence zone may be attributed to the PME due to the additional stresses concentrated near the earth's surface. Thus, as far as the Chugoku-Kinki District is concerned, the characteristic pattern of the secular variation anomalies revealed seems to be able to be qualitatively explained from the present model.

As for the Shikoku District, it seems likely that there is not so clear a correlation between the pattern

of the secular variation anomalies and that of the crustal movement or the topographic structure in the region. However, the pattern of the anomalies seems to suggest that there exists some heterogeneity in the stress field within the upper crust so far as the PME is concerned. From the view point of the seismological study, it is considered that the northern part of the Shikoku region beyond the Median Tectonic Line, which runs through the region from west to east, is under a horizontal compression in the east to west direction. This compression probably arises from a source common to that in the Chugoku-Kinki District. On the other hand, the southern part of the region is considered to be subjected to another horizontal compression in the north-west direction(Shiono³³⁾). This compression is considered possibly to arise from the subduction of the Philippine Sea plate sinking along the Nankai trough. Such a complicated stress field could possibly account for the complicated pattern of the secular variation anomalies in the Shikoku District although the anomaly pattern might likely be the result of two different stress fields.

5.3 Estimation of stress change in the upper crust

In the previous Sections, we interpreted the observed anomalies of the secular variations in the total magnetic field as probably being caused by the PME. To confirm this interpretation, it is necessary to estimate the expected stress change in the upper crust on the basis

of the PME and compare it with other geophysical data. However, it is quite difficult to completely solve this inversion problem. There are too many uncertainties and unknown factors such as the stress distribution within the upper crust, the stress sensitivity of the crustal rock and its magnetization, particularly at relatively deep parts of the crust as deep as 20 km. Here, we make a rough estimation of the stress change by using a simple model of stress distribution and the data available as to the stress sensitivity and the magnetization of the crustal rock.

We first assume that $\Delta\sigma_y$ is a function of only 'y' (positive to the east as defined in Fig. 15) as expressed by

$$\Delta\sigma_y = \Delta\sigma_m \cos \frac{2\pi}{L}y \quad \dots\dots\dots(17)$$

where, $\Delta\sigma_m$ is the maximum of the stress change and L is wavelength of the folding or undulation in topography. Substituting Eq. (17) into Eq. (16), then ΔJ_z is given as

$$\Delta J_z = \beta J \frac{0}{z} \frac{\Delta\sigma_m}{2} \cos \frac{2\pi}{L}y \quad \dots\dots\dots(18)$$

In the above equation, the contribution of $\Delta\sigma_x$ to ΔJ_z is ignored because $\Delta\sigma_x$ is assumed to be uniform everywhere in the present model and therefore a uniform increment of ΔJ_z due to $\Delta\sigma_x$ is not taken into consideration as we are simply concerned with the relative secular variation.

The change in the vertical component, Z, of the

magnetic field on the earth's surface can be calculated from volumetric integral over the layer considered as follows;

$$\Delta Z = -\frac{\partial^2}{\partial z^2} \int_{-\infty}^{+\infty} \int_{-\infty}^{+\infty} \int_0^D \frac{\Delta J_z}{r} dx' dy' dz' \dots \dots (19)$$

where $r = \sqrt{(x - x')^2 + (y - y')^2 + (z - z')^2}$, x', y' and z' are the coordinates fixed on the layer, being assigned as positive to the north, east and down, respectively, and D is the thickness of the layer. In the above integration, the undulation of the earth's surface is practically ignored because the height of the undulation is no more than about 1 km, while the horizontal wavelength of the undulation is longer than 80 km and the thickness of the layer is assumed to be 20 km. By substituting Eq. (18) into Eq. (19) and integrating the right-hand side of Eq. 19, we can get

$$\Delta Z = \pi(1 - e^{-\frac{2\pi D}{L}}) \beta J_z^0 \Delta \sigma_m \cos \frac{2\pi}{L} y \dots \dots (20)$$

Since the change of the total magnetic field is given by $\Delta F = \Delta Z \sin I$, where I is the magnetic inclination, we can finally give the change of the total magnetic field by

$$\Delta F = \pi(1 - e^{-\frac{2\pi D}{L}}) \beta J_z^0 \Delta \sigma_m \cos \frac{2\pi}{L} y \sin I \dots (21)$$

Although we do not actually know the real value of the magnetization, J_z^0 , in the crustal layer, we will tentatively assume it to be $5 \times 10^{-3} \text{ emu/cm}^3$.

This value has been adopted as a representative figure in the upper crust by a number of researchers (for example, Nagata¹²⁾). Inouchi³⁹⁾ also suggested that the geomagnetic anomalies in the Sanin area revealed from the aeromagnetic surveys are caused by magnetized bodies whose magnetization is probably 5×10^{-3} emu/cm³ existing at a depth of 12 km. The stress sensitivity is also one of the unknown factors. According to Nagata¹¹⁾, $\beta = (0.5 - 5) \times 10^{-3}$ cm²/kg is derived from laboratory experiments. It has been pointed out by Stacey and Johnston¹⁰⁾ that the stress sensitivity of the titanomagnetite-bearing rocks increases sensitively depending upon the content of Fe₂TiO₄. Carmichael⁴⁰⁾ has showed that the stress sensitivity of magnetite increases as hydrostatic pressure increases. Therefore, we tentatively adopt $(2 - 3) \times 10^{-3}$ cm²/kg as the value of the stress sensitivity for the upper crustal layer in expecting that there may be abundant mafic rocks, which contain rich Fe₂TiO₄, beneath the earth's surface. Finally, by substituting these values and the value of the magnetic field change, $\Delta F = 1$ nT/yr, into Eq. 21, we get 3 - 5 bals/yr of the stress change required to produce the observed secular variation anomalies. If it is accepted that the value of the crustal magnetization is as large as 10^{-2} emu/cm³, then the stress change expected would reduce by one half of the value calculated above.

5.4 Oscillatory stress change in the earth's crust

We have just showed that the piezomagnetic model can qualitatively explain the observed local anomalies of the secular variation. However, the amount of the estimated stress change seems to be a little too large to be accepted as realistic when we compare it with that deduced from the data of the geodetic measurements. Some consider that it may be far less than 1 bar/yr. Moreover, if the stress estimated in the present model is built up year by year with a constant rate within the upper crust, then total accumulation of the stress over a long period will be very large. After one hundred years, for example, it would reach several hundred bars enough to produce a major earthquake. There are no frequent occurrences of such major earthquakes in the region concerned although a lot of micro and small earthquakes have ceaselessly occurred particularly along active faults in the region.

This discrepancy can not be solved at present. In order to overcome this problem, it will be necessary to know the real magnetization of the crustal rock and its stress sensitivity at relatively deep parts of the crust, down to 20 km in depth. In any case, stresses accumulated must be released in some reasonable way. If not, increasing magnetization due to the stress accumulation would reach an extremely large amount, so that a very large magnetic anomaly in the

main field would appear in the region. Such large anomalies can not be found in the region as shown in Fig. 11. Needless to say, it is unreasonable to assume that the crustal rock is able to undergo an extremely large amount of stress beyond perhaps several hundred bars. It is natural to infer that most of the stresses accumulated would be released as seismic wave energy when the stresses reach a certain amount or limit, while some portion of the stresses would remain unreleased and result in permanent, or nonelastic, deformation of the crust such as the development of the folding or movement of the crustal block. In other words, the crustal deformation is essentially composed of elastic behavior and nonelastic behavior. The deformation related to earthquake occurrences is substantially elastic or visco-elastic. This deformation will be oscillatory with certain periods. The local anomalies of the secular variation would be related to such elastic and oscillatory movements of the upper crust. It should be mentioned that we see only the transient parts of the secular variation which go on for a period from several decades to perhaps a few hundred years. The magnetic changes observed do not directly reflect the development of the folding but rather the temporal and elastic deformation of the upper crustal layer due to the tectonic forces. If this consideration is acceptable, a major earthquake which will occur in and around the region concerned

in the future would give rise to the disappearance of the secular variation anomalies in the region. Thenceforth a new stage of the secular variation anomaly would start again as a new accumulation of the stress progresses within the upper crust.

As an evidence of such oscillatory crustal movements in the Chugoku-Kinki District, the vertical movement along the levelling route (Yonago-Kurashiki) in the Chugoku District are quite noteworthy. This was revealed from the levelling survey carried out in two successive periods (1891-1935, 1935-1948.1951) by the G.S.I. The result analyzed by Miyamura and Mizoue⁴¹⁾ is shown in Fig. 17. The crustal movement seems to be evidently oscillating but non-progressive with time during the period of the last several decades at least. Moreover, it is also worthwhile to mention that during the period concerned three comparatively large earthquakes occurred in the region: the Tazima earthquake of $M=7.0$ in 1925, the Tango earthquake $M=7.4$ in 1927 and the Tottori earthquake $M=7.3$ in 1943.

Tanaka et al.⁴²⁾ suggested that the crustal movement in the northwestern part of the Kinki District is non-progressive. They derived this fact from continuous observations of the crustal movements by means of tiltmeters and extensometers at Ikuno mine which is located in the northwestern Kinki District. They further found that the vector of secular ground tilting in

that area gradually changed its direction twice during a period of 20 years, 9-10 years for each direction. They also pointed out that these anomalous changes were closely correlated to the seismic activity in the Kinki District, and they suggested that a reversal of the vertical crustal movement occurred, from upheaval to subsidence around 1925 in the Ikuno region. ^{According to} Tanaka's opinion on the crustal movement, is that the crustal strain is accumulated and released alternately during a period of about 10 years for each in most cases, so that the oscillatory crustal movement with an interval longer than several decades will be superimposed on the oscillatory movement of a short period. This seems to strongly support our consideration that the observed anomalies of the secular variation is attributable to the PME and that the local anomaly is an indicator of the stress accumulation only for a transient period in a long history of stress change within the crust. We believe that the oscillatory change of the magnetic field is observable, depending upon the oscillatory stress accumulation within the upper crust if we repeatedly make magnetic surveys in a region over a long period of time.

6. Conclusion

The characteristic distribution of the local anomalies of the secular variation in the total magnetic field was revealed in the region broadly covering the Chugoku-Kinki and the Shikoku Districts in the southwestern region of Japan. The local anomalies were derived from the analyses of the data obtained from the magnetic surveys repeated during a period of about 8 years at more than 100 magnetic stations.

Features of the anomalies were fairly characteristic and systematic in their arrangements. Especially, in the Chugoku-Kinki District, the pattern of arrangement of the anomalies appeared to correlate well with features of the recent crustal movements in the region; the distinctive distribution of the positive and the negative anomalies of the secular variation seemed to resemble closely that of the positive and the negative dilatations of the earth's surface which was revealed from analyzing the data of the geodetic measurements (triangulation). The average anomaly was of about ± 1 nT/yr for each of the positive and the negative zones. It was confirmed from the latest resurvey of the total magnetic field in the northwestern Chugoku region that some of the anomalies have continued in a similar pattern at an almost constant rate for at least the last several decades.

Interpretation of these anomalies was made on the basis of the piezomagnetic effect under the assumption

that a non-uniform stress change in the upper crust has taken place. It was considered that this stress change might result primarily from the horizontal compression associated with the motion of the Pacific Ocean plate and the Philippine Sea plate, and secondly from the stress concentration in the folded upper layer of the crust arising from the buckling of the layer due to horizontal compression. The piezo-magnetic model proposed could well explain qualitatively the characteristic arrangement of the anomalies in the Chugoku-Kinki District. However the stress changes estimated by using the present model were somewhat large, amounting to 3-5 bars/yr, which are difficult to be accepted as realistic values. This overestimation may arise partly from inadequateness of the assumed stress distribution and partly from uncertainties of the stress sensitivity and the magnetization of the crustal rock. These should be modified in the future. However, even if the annual stress change in the layer is small, the total stress accumulation over a long period of time would reach an extremely large amount, much more than the crustal rock could bear without some form of breakdown. To overcome this discrepancy it was suggested that the accumulated stress would probably be released in the form of seismic wave energy and during that time the local anomalies of the secular variations would disappear. It was also assumed that the local anomalies would simply

reflect the stress accumulation within the crust for a shorter period, possibly from several decades to as much as several hundred years, compared to the geological time as the folding develops.

As for the anomalies observed in the Shikoku District, it was not possible to find so clear a correlation between the feature of the crustal movements and that of the arrangement of the local secular variation anomalies as seen in the Chugoku-Kinki District although the positive and the negative anomalies were easily distinguishable. This may be due to the fact that the stress field within the upper crust, deduced from the seismological studies, is very complicated because the region is considered to be subjected to two horizontal compressions from different directions. These compressions probably result from the motions of the Pacific Ocean and Philippine Sea plates. It seems quite likely that the anomaly pattern reflects these stress fields.

Finally it will be suggested that in order to truly detect the long term precursory changes in the magnetic field, it is very important to examine the features of local anomalies of the secular variation which will probably be related to the tectonic force prevailing in the regions concerned and probably not to any particular earthquake occurrence. If successive and comprehensive magnetic surveys are made in the tectonically active zones in other regions of the world, the local anomalies of the secular variation related to the tectonic forces will be found.

Acknowledgements

I would like to sincerely thank Professors Tokio Ichinohe and Yoshimichi Kishimoto for their encouragement and generous advice throughout the course of this study. I am also grateful to Professors Takeshi Yukutake, Hiroshi Maeda, Sadao Sasajima and Ichiro Nakagawa for critically reading the manuscript and for their valuable comments. I wish to acknowledge the valuable discussions with the members of the Conductivity Anomaly Research Group and the Tectonophysics Research Group in Japan. The interest and helpful suggestions offered from Professors Kazuo Oike, Kazuo Huzita, Junichiro Miyakoshi, Mr. Yutaka Tanaka and Mr. Kazuo Mino are greatly appreciated. I am also indebted to Mr. Masakuni Hashida for kindly offering the computer program of the finite element method. I would further like to express my thanks to the members of the Tottori Microearthquake Observatory and many students of Kyoto University for their kind help concerning the observations. I am also indebted to the members of the Kakioka Magnetic Observatory and the Geographical Survey Institute for kindly offering useful magnetic data.

References

- 1) Tazima, M., H. Mizuno and M. Tanaka: Geomagnetic secular change anomaly in Japan, *J. Geomag. Geoelectr.*, 28, 1976, pp. 69-84.
- 2) Johnston, M. J.: Local magnetic field variations and stress changes near a slip discontinuity on the San Andreas Fault, *J. Geomag. Geoelectr.*, 30, 1978, pp. 511-522.
- 3) Shapiro, V. A., A. N. Pushkov, K. N. Abdullabekov, E. B. Berdaliev and M. Yu. Muminov: Geomagnetic investigations in the seismo active regions of Middle Asia, *J. Geomag. Geoelectr.*, 30, 1978, pp. 503-509.
- 4) Sasai, Y. and Y. Ishikawa: Changes in the geomagnetic total force intensity associated with the anomalous crustal activity in the eastern part of the Izu peninsula (2) - The Izu-Oshima-kinkai earthquake of 1978, *Bull. Earthq. Res. Inst., Univ. Tokyo*, 53, 1978, pp. 893-923.
- 5) Yukutake, T., T. Yoshino, K. Otani, E. Kimoto, T. Shimomura and Y. Ishikawa: Anomalous secular variation in the geomagnetic total intensity on Oshima volcano, *Bull. Earthq. Res. Inst., Univ. Tokyo*, 53, 1978, pp. 881-892.
- 6) Davis, P. M., F. D. Stacey, C. J. Zablock and J. V. Olson: Improved signal discrimination in tectonomagnetism: Discovery of a volcanomagnetic effect at Kilauea, Hawaii, *Phys. Earth Planet. Inter.*, 19, 1979, pp. 331-336.
- 7) Kern, J. W.: Effect of stress on the susceptibility

- and magnetization of a partially magnetized multidomain system, *J. Geophys. Res.*, 66, 1961, pp. 3807-3810.
- 8) Ohnaka, M. and H. Kinoshita: Effect of uniaxial compression on remanent magnetization, *J. Geomag. Geoelectr.*, 20, 1968, pp. 93-100.
 - 9) Nagata, T.: Basic magnetic properties of rocks under the effects of mechanical stresses, *Tectonophysics*, 9, 1970, pp. 167-195.
 - 10) Stacey, F. D. and M. J. S. Johnston: Theory of the piezomagnetic effect in titanomagnetite bearing rocks, *Pure Appl. Geophys.*, 97, 1972, pp. 146-155.
 - 11) Nagata, T.: Application of tectonomagnetism to earthquake phenomena, *Tectonophysics*, 14, 1972, pp. 263-271.
 - 12) Nagata, T.: Tectonomagnetism in relation to seismic activities of the earth's crust: Seismomagnetic effect in a possible association with the Niigata earthquake in 1964, *J. Geomag. Geoelectr.*, 28, 1976, pp. 99-111.
 - 13) Yukutake, T. and H. Tachinaka: Geomagnetic variation associated with stress change within a semi-infinite elastic earth caused by a cylindrical force source, *Bull. Earthq. Res. Inst., Univ. Tokyo*, 45, 1967, pp. 785-798.
 - 14) Shamsi, S. and F. D. Stacey: Dislocation models and seismomagnetic calculations for California 1906 and Alaska 1964 earthquakes, *Bull. Seismol. Soc. Amer.*, 59, 1969, pp. 1435-1448.
 - 15) Rikitake, T.: Elimination of non-local changes from total intensity values of geomagnetic field, *Bull. Earthq. Res. Inst., Univ. Tokyo*, 44, 1966, pp. 1041-1070.

- 16) Beahn, T. J.: Geomagnetic field gradient measurements and noise reduction techniques in Colorado, J. Geophys. Res., 81, 1976, pp. 6276-6280.
- 17) Ware, R. H. and P. L. Bender: Noise reduction techniques for use in determining local geomagnetic field changes, J. Geomag. Geoelectr., 30, 1978, pp. 533-537.
- 18) Sumitomo, N.: Geomagnetism in relation to tectonic activities of the earth's crust in Japan, J. Phys. Earth, 25, Suppl., 1977, pp. 147-160.
- 19) Skovorodkin, Yu. P., L. S. Buzuglaya and T. V. Guseva: Tectonomagnetic studies in Tajikistan, J. Geomag. Geoelectr., 30, 1978, pp. 431-486.
- 20) Shapiro, V. A., A.L. Aleinikov, A. A. Nulman, V. A. Pyankov and A. V. Zubkov: Secular variation anomalies and aseismic geodynamic in the Urals, J. Geomag. Geoelectr., 30, 1978, pp. 493-502.
- 21) Mundt, W.: Geomagnetic secular variation anomalies in the GDR, J. Geomag. Geoelectr., 30, 1978, pp. 523-531.
- 22) Sumitomo, N.: Quaternary crustal movement and anomaly of geomagnetic secular variation, J. Geod. Soc. Japan, 18, 1972, pp. 89-91. (The Second Order Magnetic Survey of Japan(6),
- 23) The Geographical Survey Institute: , Bull. Geogr. Surv. Inst., 17, 1972. pp. 12-35.
- 24) The Geographical Survey Institute: , Bull. Geogr. Surv. Inst., 15, 1970, pp. 1-60. (Summary of results of the First Order Magnetic Survey,
- 25) Rikitake, T.: The undulation of an electrically conductive layer beneath the islands of Japan, Tectonophysics, 7, 1969, pp. 257-264.
- 26) Sumitomo, N.: Geomagnetic variation anomaly in the

- vicinity of Tottori, facing the Japan Sea, in the southwestern Japan, Contr. Geophys. Inst., Kyoto Univ., 12, 1972, pp. 117-128.
- 27) Tazima, M.: Accuracy of recent magnetic survey and a locally anomalous behaviour of the geomagnetic secular variation in Japan, Bull. Geogr. Surv. Inst., 13, 1968, pp. 1-78.
- 28) Sumitomo, N.: Anomalous secular variation of geomagnetic total intensity in Chugoku District, Japan, Bull. Disas. Prev. Res. Inst., Kyoto Univ., 21, 1972, pp. 191-200.
- 29) Mizutani, H. and T. Ishido: A new interpretation of magnetic field variation associated with the Matsushiro earthquake, J. Geomag. Geoelectr., 28, 1976, pp. 179-188.
- 30) Ichikawa, M.: Reanalyses of mechanism of earthquakes which occurred in and near Japan and statistical studies on the nodal plane solutions obtained, 1926-1968, Geophys. Mag., 35, 1971, pp. 207-274.
- 31) Hashizume, M.: Investigation of microearthquakes- On earthquake occurrence in the crust-, Bull. Disast. Prev. Res. Inst., Kyoto Univ., 20, 1970, pp. 65-94.
- 32) Nishida, R.: Earthquake generating stress in eastern Chugoku and northern Kinki Districts, Southwest Japan, Bull. Disast. Prev. Res. Inst., Kyoto Univ., 22, 1973, pp. 197-233.
- 33) Nakane, K.: Horizontal tectonic strain in Japan (I) and (II), J. Geod. Soc. Japan, 19, 1973, pp. 190-208.
- 34) Huzita, K.: Tectonic development of Southwest Japan in

- the Quaternary period, *J. Geosci.* Osaka City Univ., 12, 1969, pp. 53-70.
- 35) Kasahara, K. and A. Sugimura: Spatial distribution of horizontal secular strain in Japan, *J. Geod. Soc. Japan*, 10, 1964, pp. 139-145.
- 36) Harrison, J. C.: Cavity and topographic effects in tilt and strain measurement, *J. Geophys. Res.*, 81, 1976, pp. 319-328.
- 37) Stacey, F. D. and S. K. Banerjee: The physical principles of rock magnetism, *Developments in solid earth geophysics*, 5, 1974, Elsevier Scientific Publishing Company.
- 38) Shiono, K.: Focal mechanism in Shikoku and Kii peninsula, southwest Japan and some problems related to the plate tectonics, *J. Geosci.* Osaka City Univ., 16, 1973, pp. 69-91.
- 39) Inouchi, N.: On the results of the aeromagnetic survey over San'in District, *J. Geod. Soc. Japan*, 17, 1971, pp. 94-99.
- 40) Carmichael, R. S.: Piezomagnetic response with depth related to tectonomagnetism as an earthquake precursor, *J. Geophys. Res.*, 30, 1978, pp. 579-584.
- 41) Miyamura, S. and M. Mizoue: Secular vertical movements of the earth's crust in Japan — Modes of movements in space and time with special reference to geotectonics — , *J. Geod. Soc. Japan*, 10, 1964, pp. 123-138.
- 42) Tanaka, Y., M. Koizumi and M. Kato: Crustal movements related to the seismic activity in a restricted area (5A) — Relation between the seismic activity in the northwestern part of the Kinki District and the crustal

movements observed at the Ikuno station —, Ann.
Disast. Prev. Res. Inst., Kyoto Univ., 13, 1970, pp.
91-108.

Table 1 Standard deviations of the hourly mean differences of 16h(local time) in the total magnetic field during about 20 days between the temporary sites and KAK or TOT(units in nT). The values of TSA are less reliable.

	TOT	MKZ	MTE	TOJ	HMD	TKS	TSA	KMT	ASO
KAK	3.3	2.5	3.5	2.3	3.0	3.6	(5.5)	3.9	7.6
TOT		0.8	1.1	0.9	0.9	1.4	(3.5)	4.0	6.8

Table 2 Overall accuracies of the data reduction for the present survey and the G.S.I. one in the region investigated(units in nT).

	ϵ_1	ϵ_{11}
Chugoku-Kinki District	3.5	1.4
Shikoku District	5.5	2.7

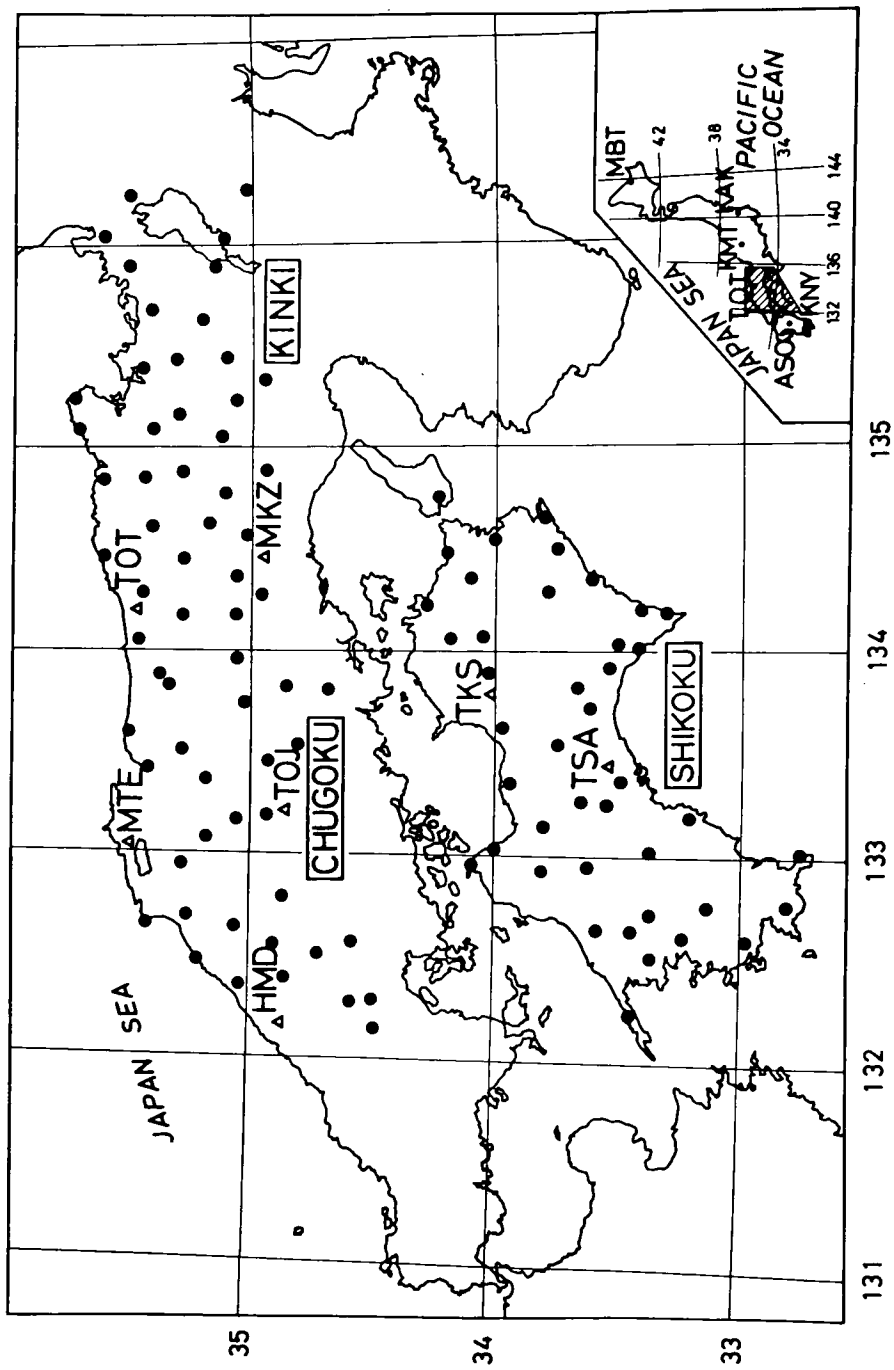

Fig. 1 Locations of magnetic stations surveyed (solid circles) and temporary sites (triangles) for the preliminary observations except for TOT, TKS and TSA which are the sub-reference stations in the present study.

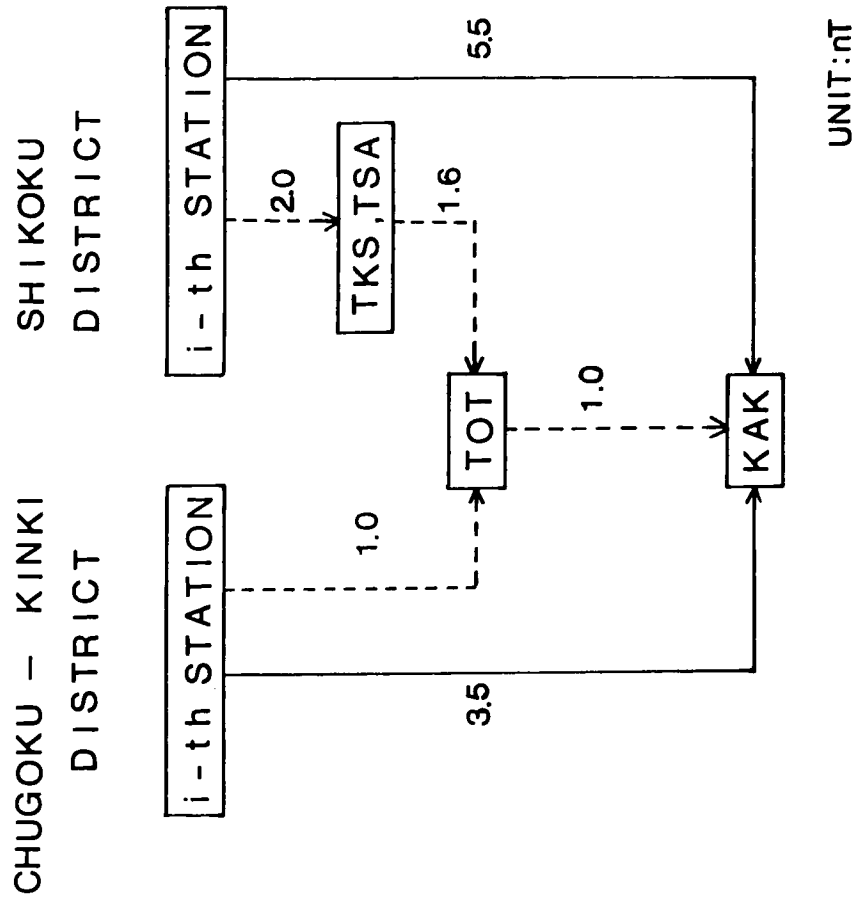

Fig. 2 Accuracies of the reduced values obtained from the present method and the G.S.I. method for data reduction.

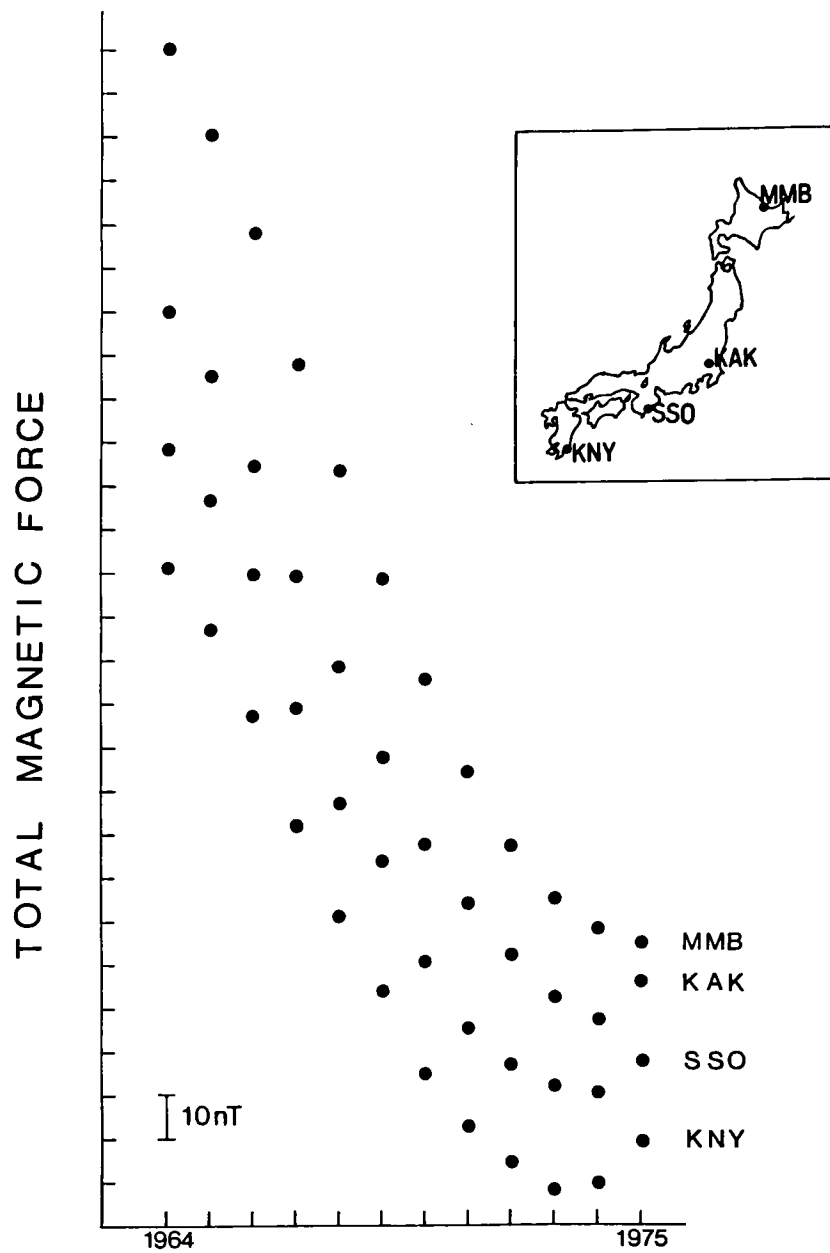

Fig. 3 Secular variations in the total magnetic field from 1964 to 1975 at the representative magnetic observatories in Japan.

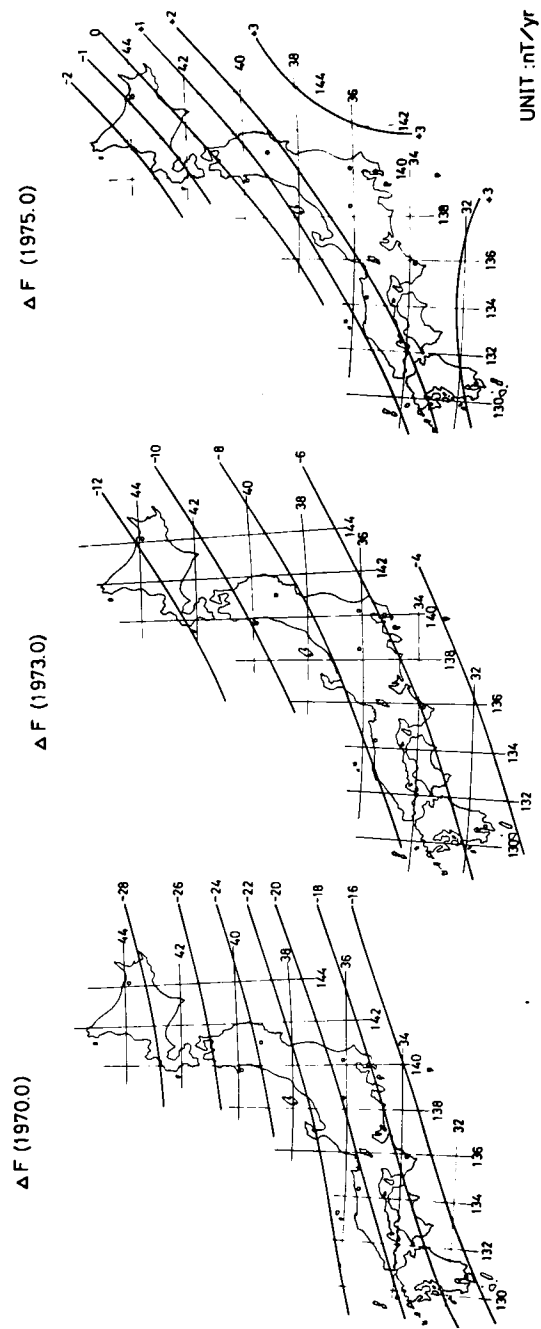

Fig. 4 Geographical distributions of the secular variations in the total magnetic field at epochs of 1970.0, 1973.0 and 1975.0.

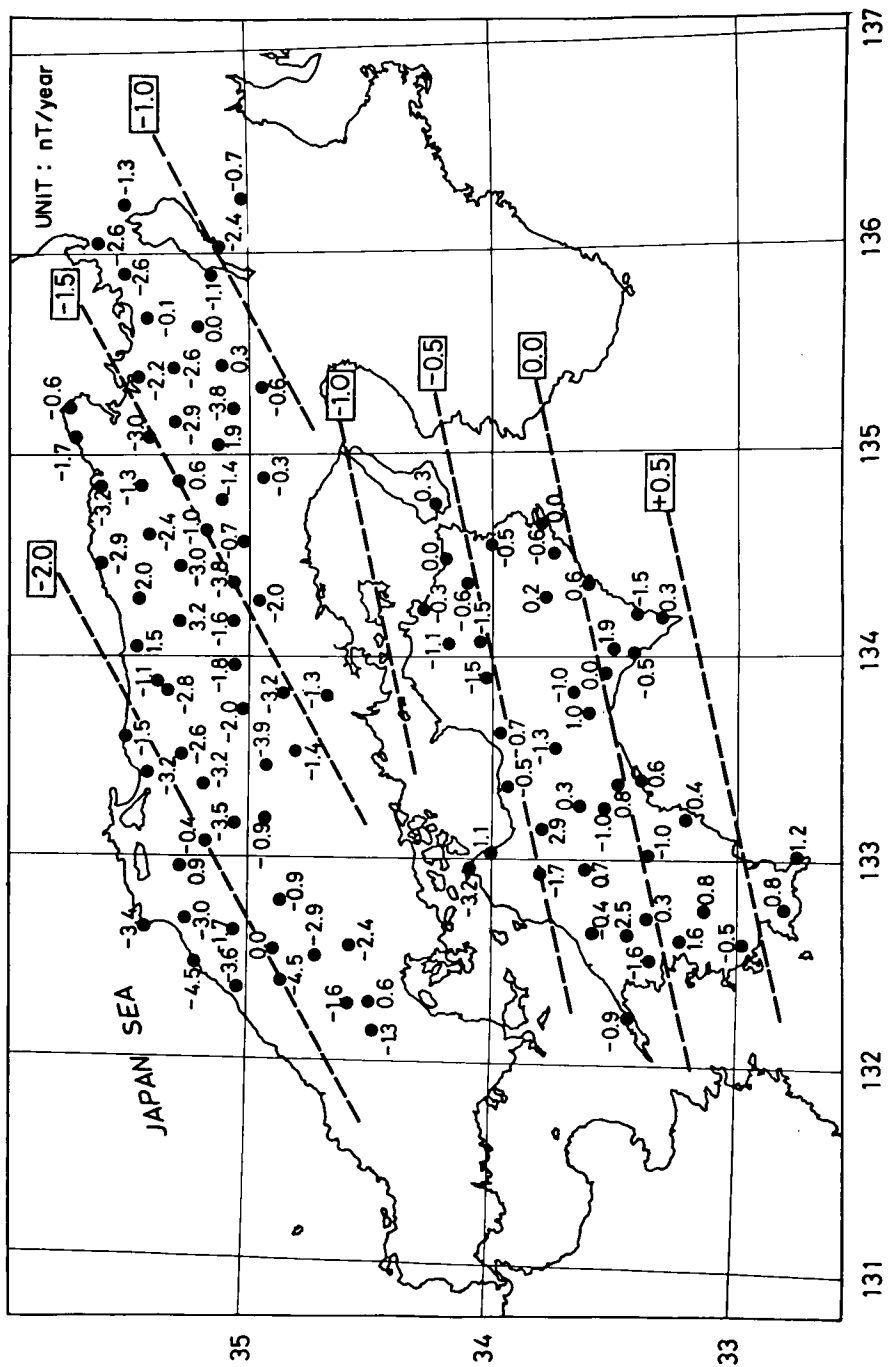

Fig. 5 Observed secular variations relative to KAK in the total magnetic field, which are indicated in terms of annual rate of change. Contours(broken lines) show the normal or regional secular variations calculated.

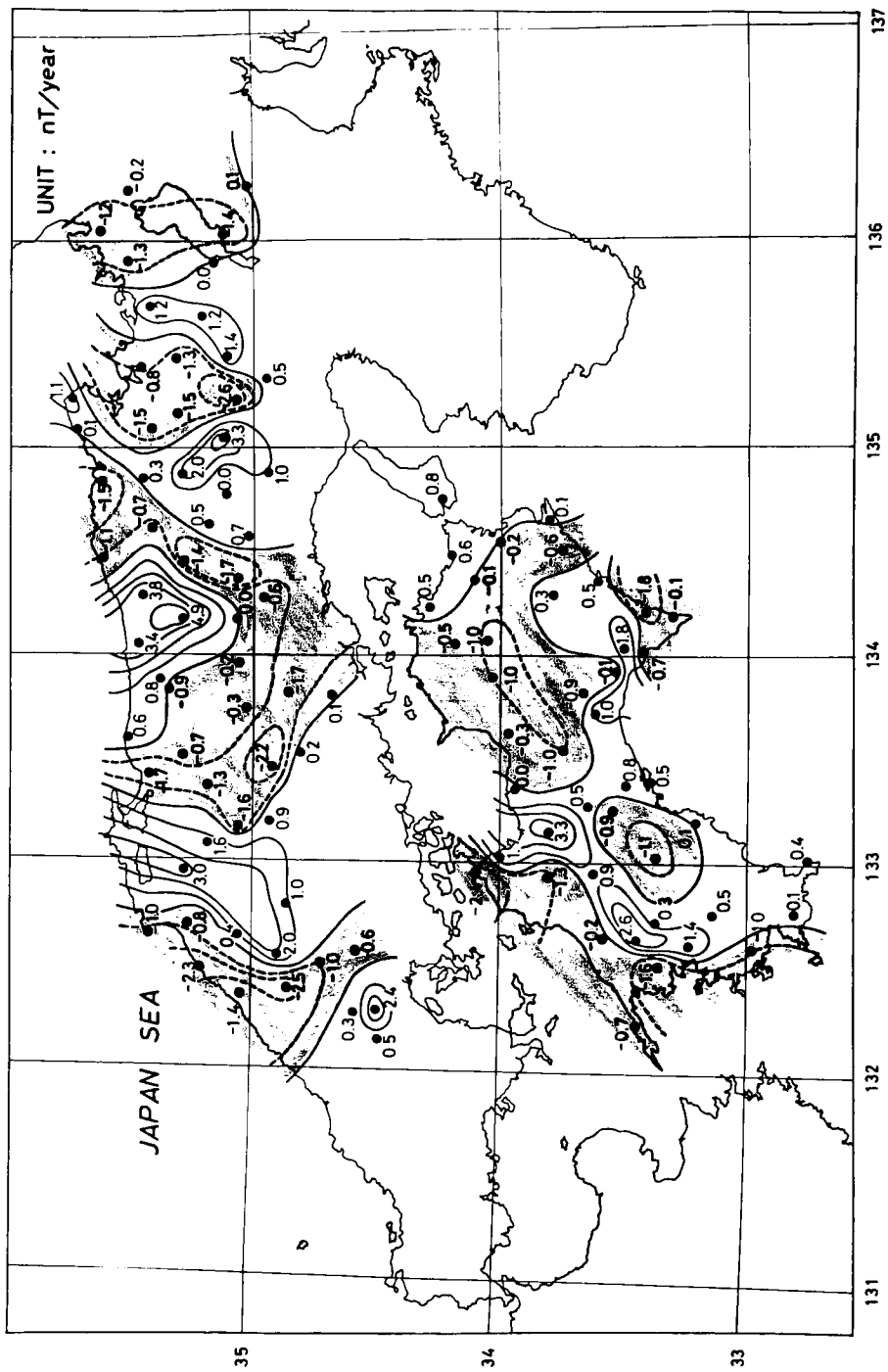

Fig. 6 Local anomalies of the secular variations in the total magnetic field in the Chugoku-Kinki and Shikoku Districts. The contour interval is +1 or -1 nT/yr.

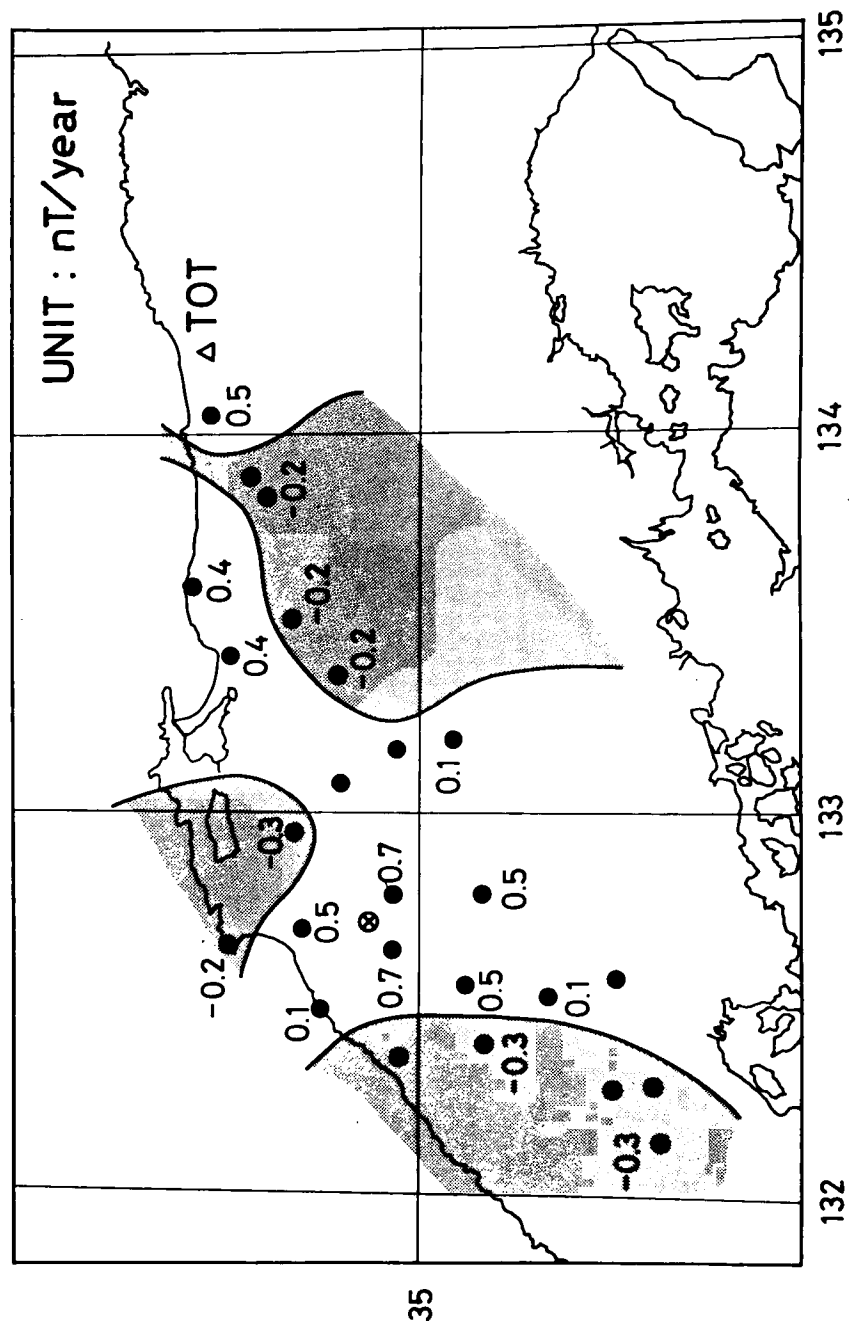

Fig. 7 Local anomalies of the secular variations in the total magnetic field in the northwestern part of Chugoku District, which were found from the resurvey carried out in 1978. \otimes indicates the epicentre of the earthquake M=6.1 which occurred on June 4 in 1978.

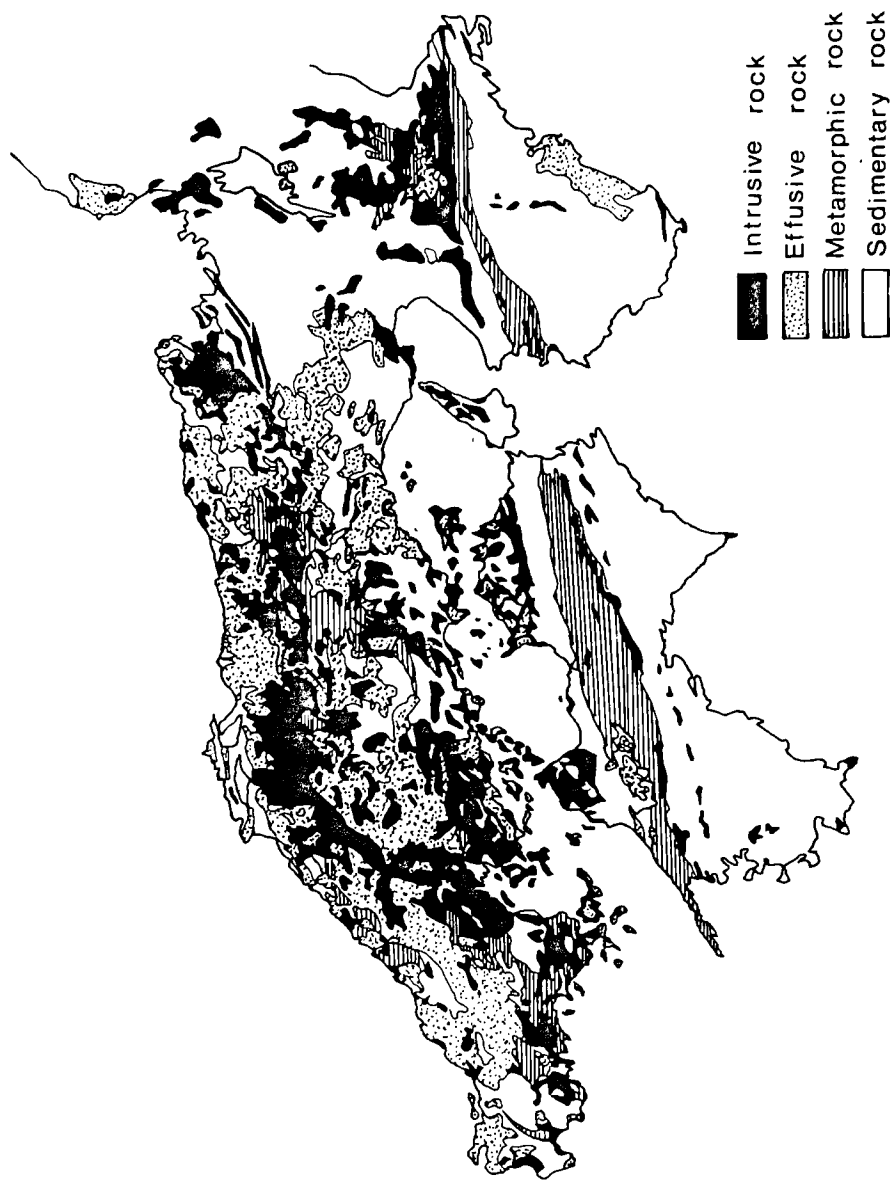

Fig. 8 Schematic map of geology in the surveyed region.

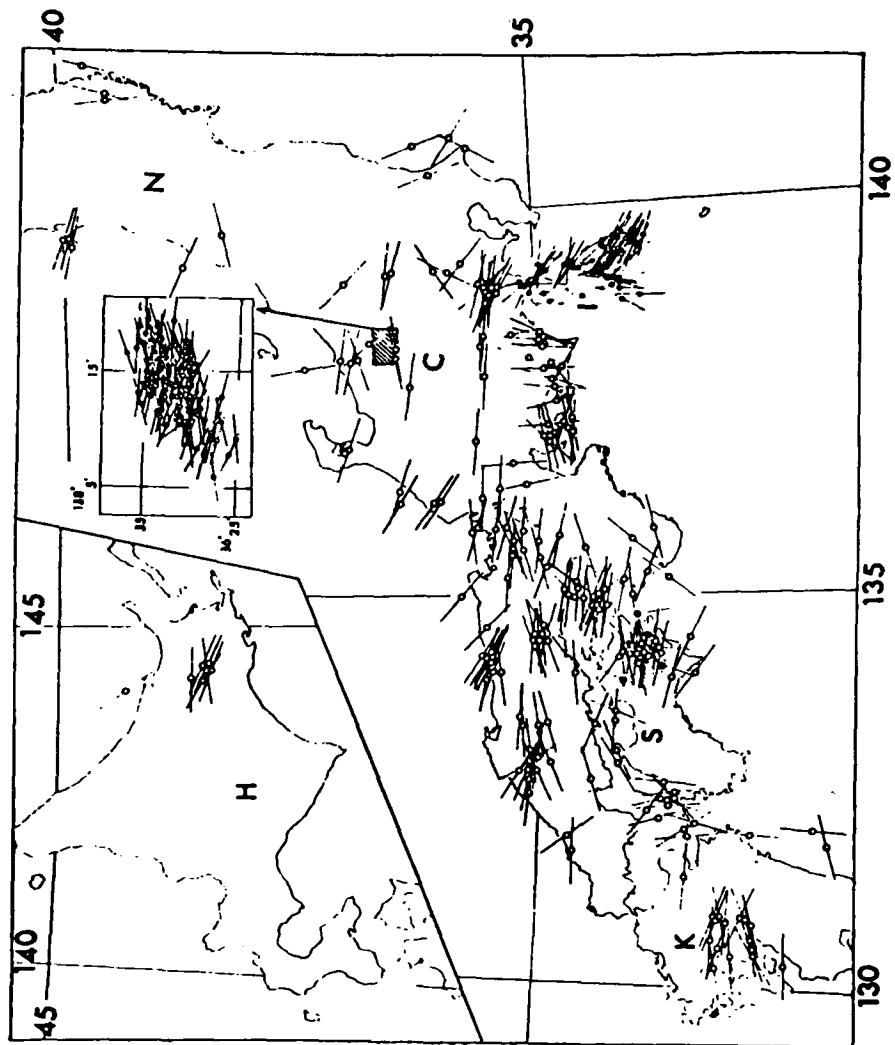

Fig. 9 Distribution of horizontal components of the maximum pressure axis for very shallow earthquakes (after Ichikawa (1971)).

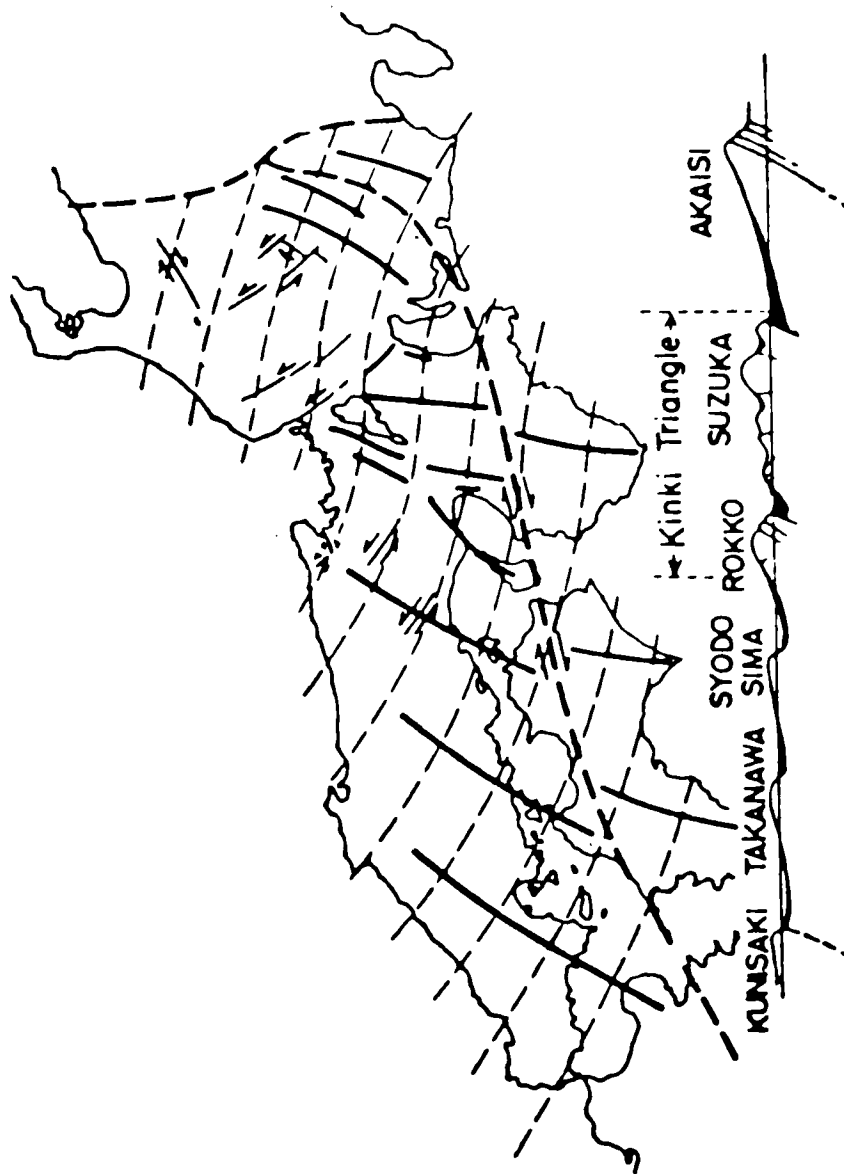

Fig.10 Distribution of axes of the maximum principal stress (compression) of the Rokko Movements(dotted lines). Solid lines are the axes of uplifts(after Huzita(1969)).

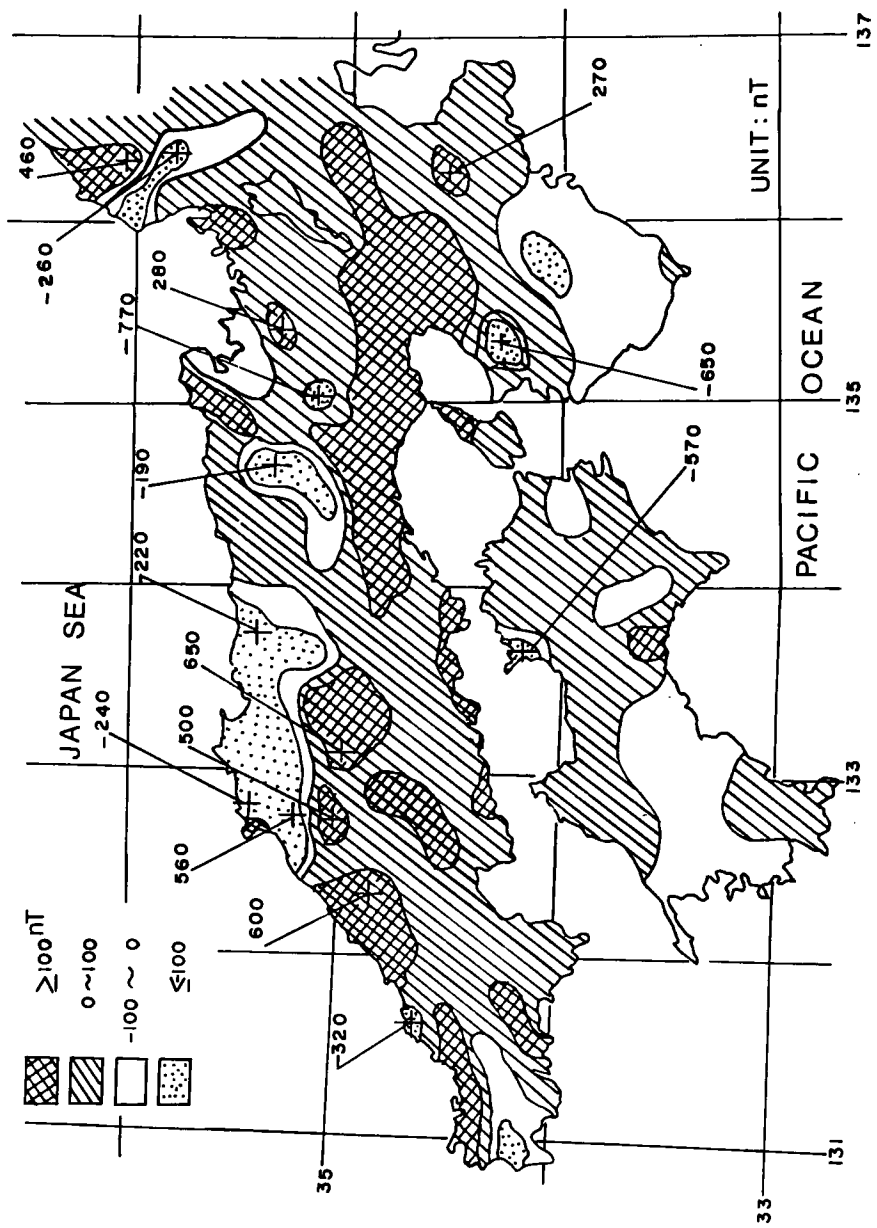

Fig.11 Anomalies of the total magnetic field in the surveyed region.

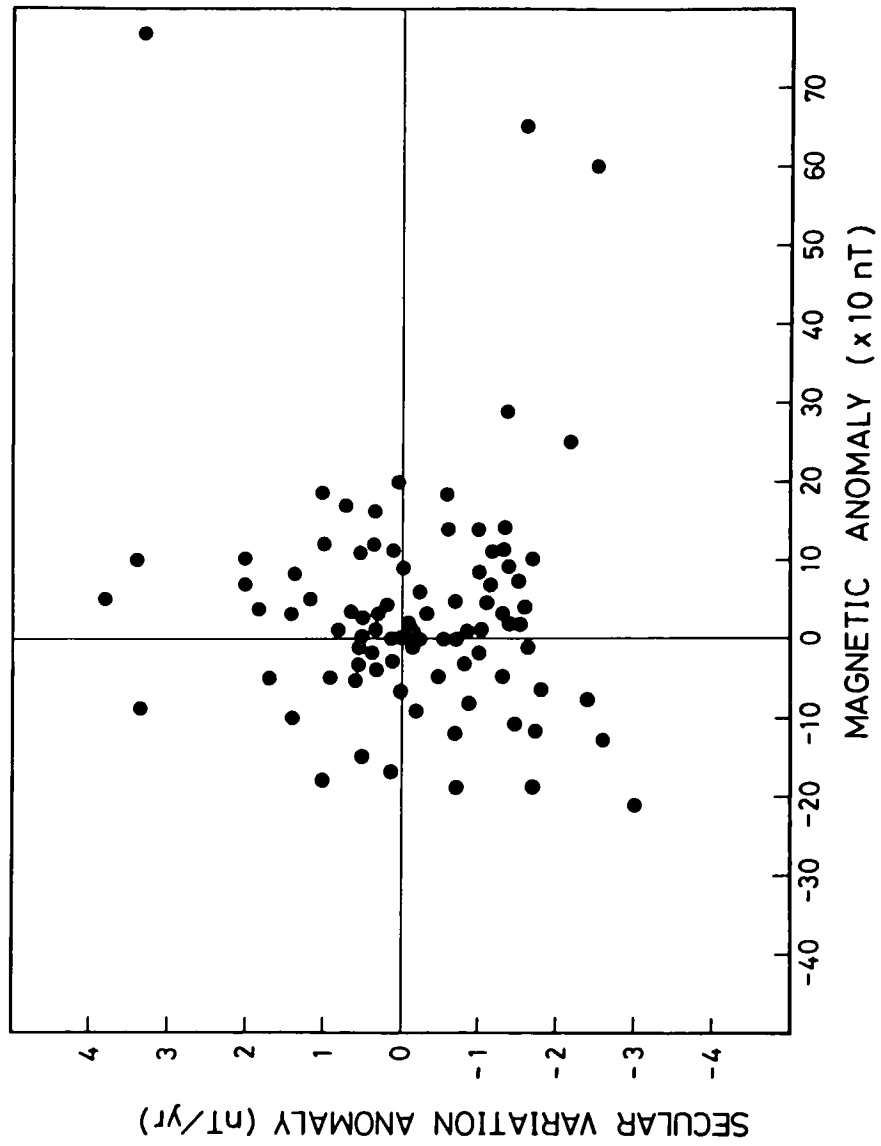
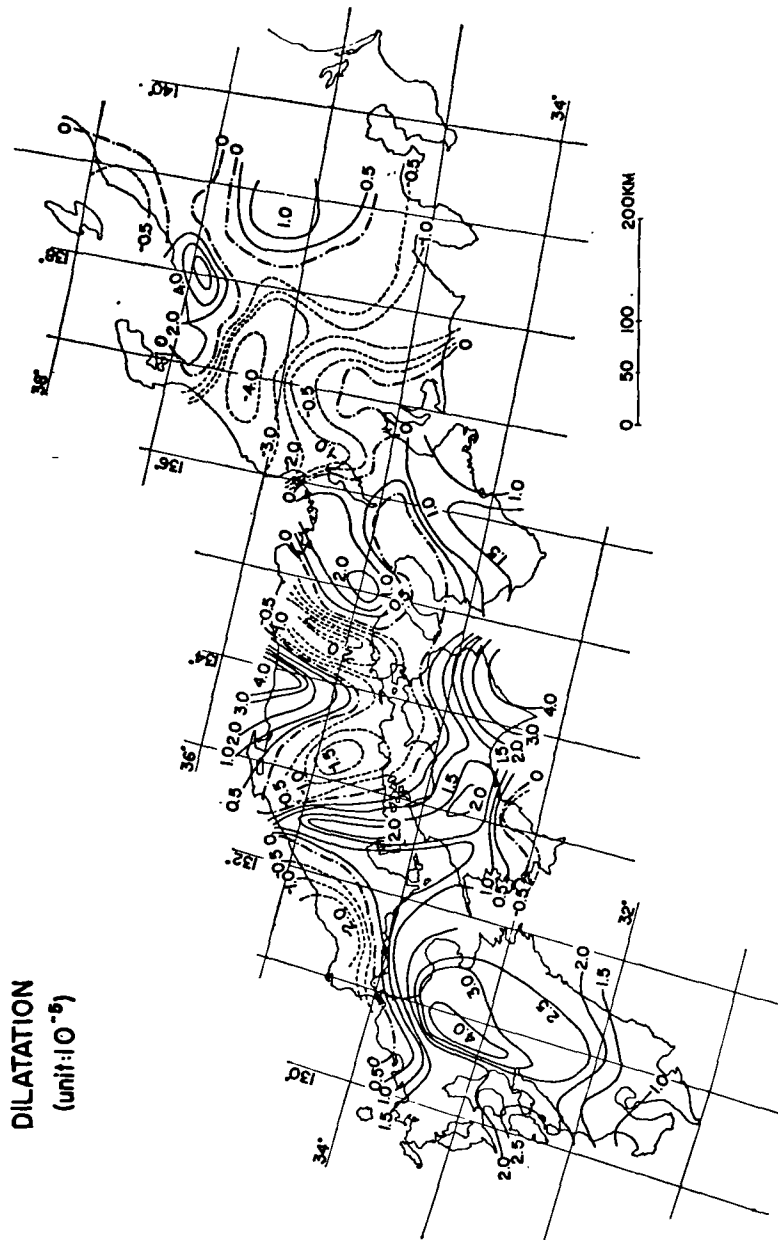

Fig.12 Correlation between the secular variation anomalies and the magnetic main field anomalies.



DILATATION
(unit: 10^{-5})

Fig.13 Dilatation in units of 10^{-5} calculated from the data of geodetic surveys(after Kasahara and Sugimura(1964)).

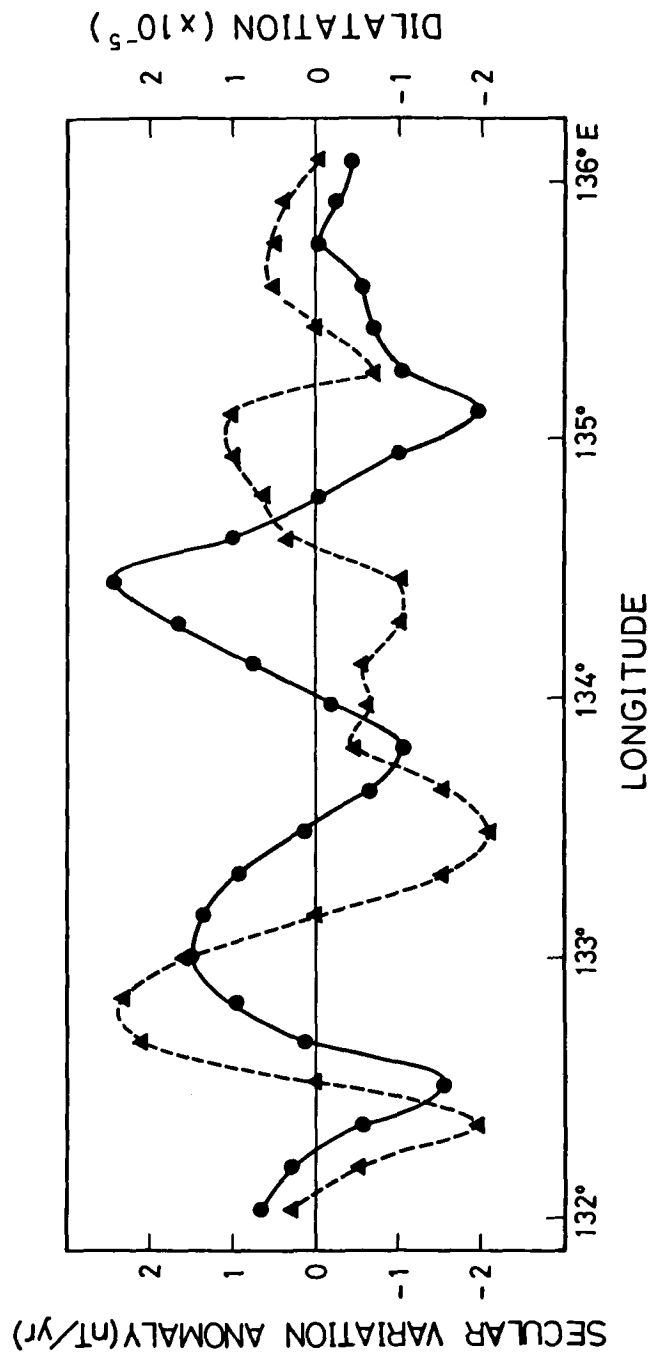

Fig.14 Profiles of the secular variation anomalies and the dilatation along a parallel of 35° north latitude.

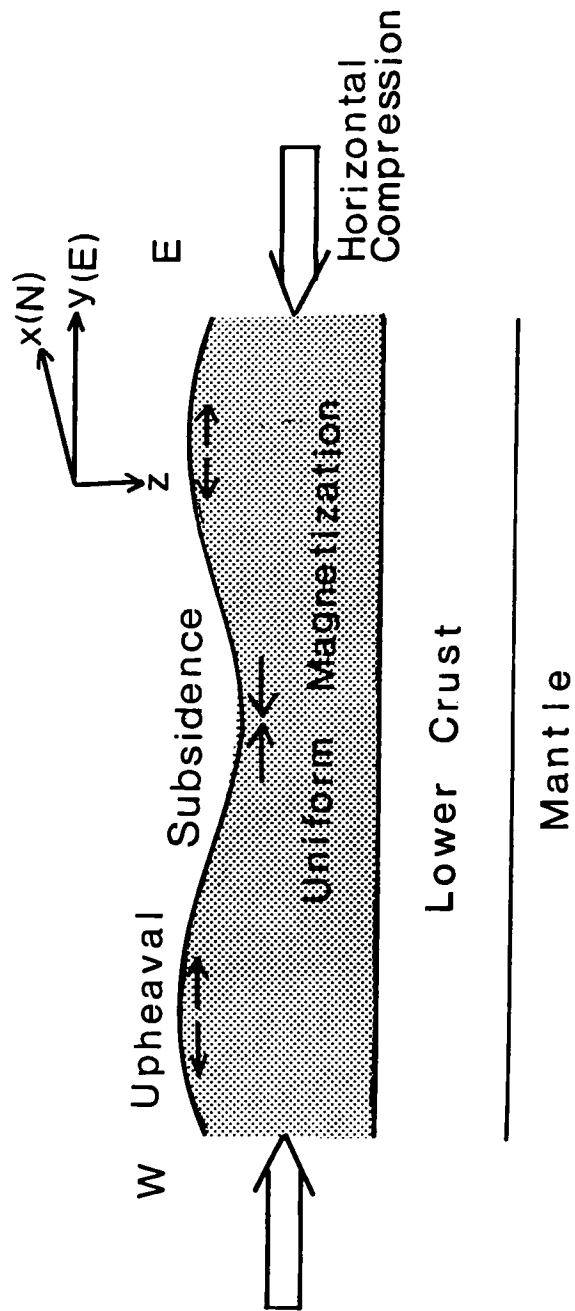

Fig.15 A model of the induced stress field in the folded layer of the upper crust which is uniformly magnetized.

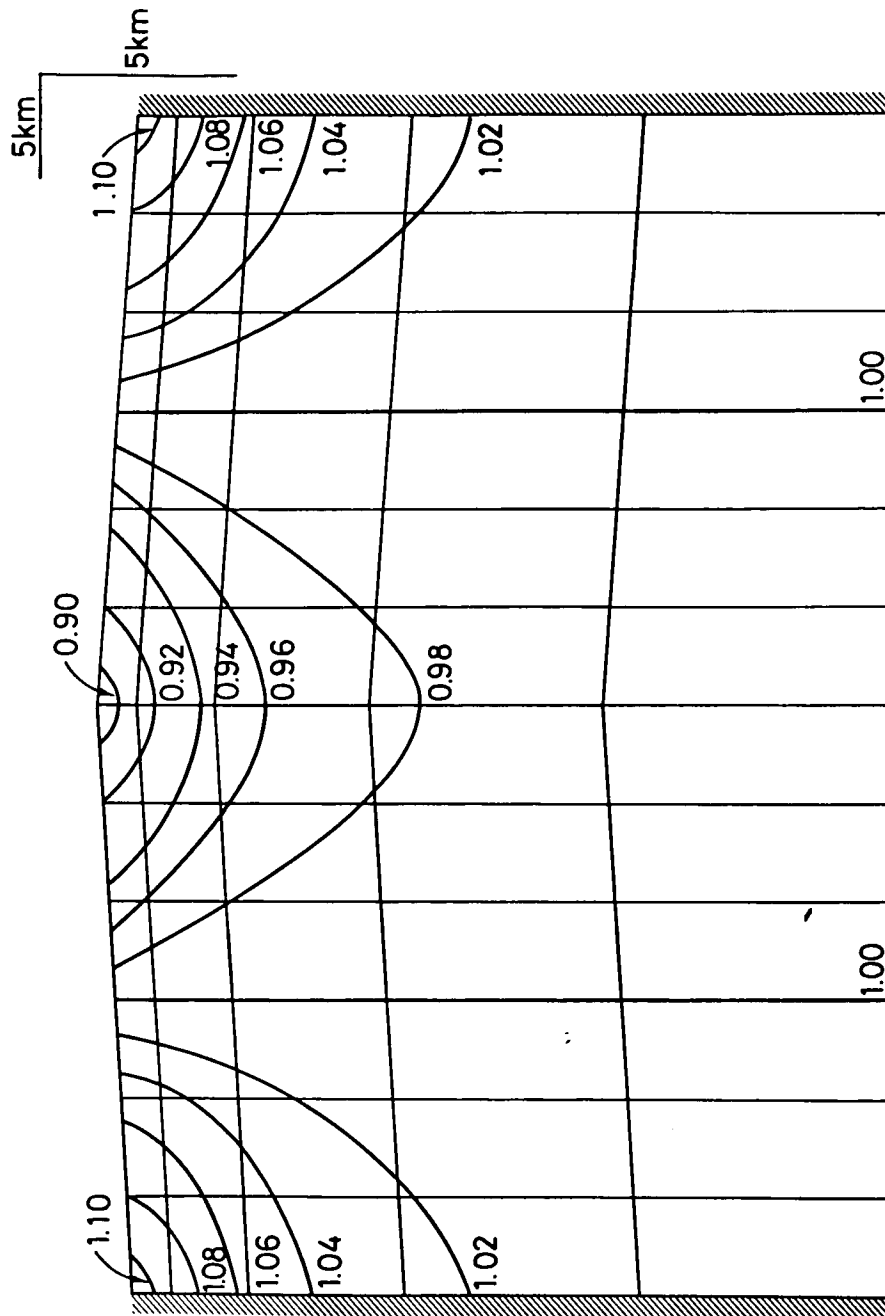

Fig.16 Strain inhomogeneity due to topographic undulation. *Strain* factors, the ratio of modified horizontal strain to the strain which would be produced in a uniform plate, are indicated by curved contours.

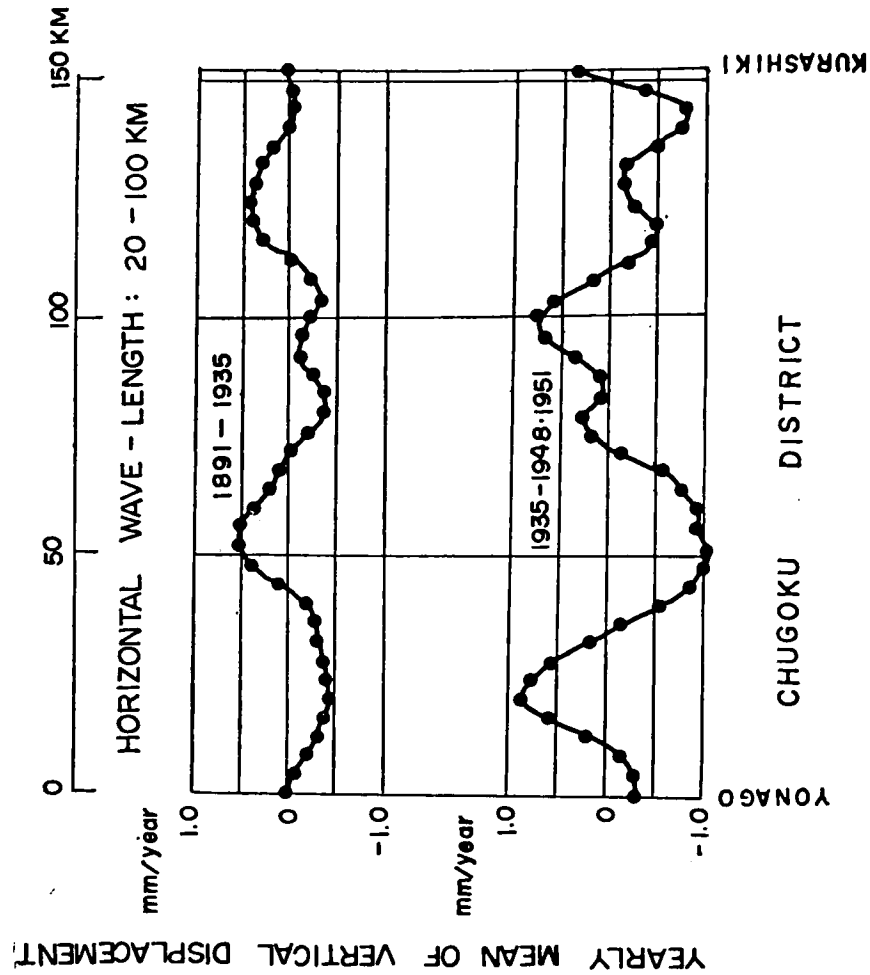

Fig.17 Vertical crustal movements in the two successive periods(1891-1935, 1935-1948-1951) with wave length range of 20-100 km on the levelling route(Yonago-Kurashiki) in the Chugoku District(after Miyamura and Mizoue(1964)).