

ANOTHER CONSTRUCTION OF COUNTEREXAMPLES TO COLEMAN'S CONJECTURE

岡 伸篤

Nobuatsu Oka
Department of Mathematics
Faculty of Science
Nagoya University
Chikusa-ku Nagoya
464 (JAPAN)

ABSTRACT

We construct another counterexample which is different from Pixton's and, using this example, we construct countably many distinct counterexamples on $\mathbb{R}^m \times \mathbb{R}^2$ ($m \geq 3$).

§1. INTRODUCTION

Suppose that ψ is a flow on \mathbb{R}^{m+n} that satisfies the following conditions:

(1) The origin $\{0\}$ is an isolated invariant set for ψ which has the isolating block $B = D^m \times D^n$ (cf. F. W. Wilson [6]). Figure 1

(2) The structure of B is

$$b^+ = \partial D^m \times D^n,$$

$$b^- = D^m \times \partial D^n,$$

$$\tau = b^+ \cap b^- = \partial D^m \times \partial D^n = S^{m-1} \times S^{n-1},$$

$$A^+ = D^m \times \{0\},$$

$$A^- = \{0\} \times D^n,$$

$$a^+ = \partial D^m \times \{0\} = b^+ \cap A^+,$$

and

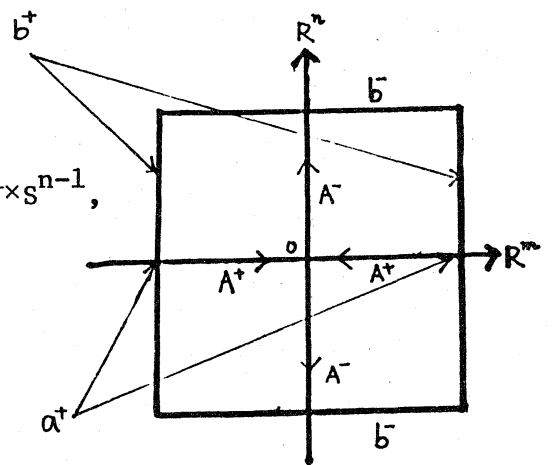

$$a^- = \{0\} \times \partial D^n = b^- \cap A^-.$$

(See Figure 1)

B^+ is the ingressing set $\{p \in \partial B \mid p \cdot (-\varepsilon, 0) \cap B = \emptyset \text{ for some } \varepsilon > 0\}$, b^- is the egressing set $\{p \in \partial B \mid p \cdot (0, \varepsilon) \cap B = \emptyset \text{ for some } \varepsilon > 0\}$, A^+ is the stable manifold $\{p \in B \mid p \cdot [0, \infty) \subset B\}$ of $\{0\}$ in B and A^- is the unstable manifold $\{p \in B \mid p \cdot (-\infty, 0] \subset B\}$ of $\{0\}$ in B . Here $p \cdot I$ means $\{\psi(p, t) \mid t \in I\}$ for any interval I .

C. Coleman [1] raised a conjecture at 5th International Conference on Nonlinear Oscillations (Kiev 1970). The following is the reformulated one in terms of the isolating blocks by Wilson [6].

Coleman's conjecture: If the flow ψ satisfies the conditions (1) and (2), then it is locally topologically equivalent to the standard hyperbolic example ψ_{mn} generated by the differential equations

$$\dot{x} = -x, \quad \dot{y} = y \quad (x, y) \in \mathbb{R}^m \times \mathbb{R}^n.$$

We say that ψ is locally topologically equivalent to ψ_{mn} at $\{0\}$ if there is a homeomorphism $\chi: U \rightarrow \chi(U) \subset \mathbb{R}^{m+n}$ on some neighbourhood U of $\{0\}$ that takes each orbit segment of ψ in U onto an orbit segment of ψ_{mn} in $\chi(U)$ and preserves the natural orientation of the orbits. Note that, in this conjecture, U is the isolating block B of ψ and $\chi(U)$ is the isolating block B of ψ_{mn} .

In 1980, D. A. Neumann [2] constructed the first counterexample in the case that both A^+ and A^- are two dimensional, i.e., he showed that there is a flow ψ on $\mathbb{R}^2 \times \mathbb{R}^2$ that is not topologically equivalent at $\{0\}$ to ψ_{22} . Furthermore, he constructed uncountably many distinct counterexamples (cf. [3]). R. B. Walker [5] also gave the counterexam-

ple in the case that either A^+ or A^- is two dimensional. On the other hand, Wilson [8] showed that the conjecture is true when A^+ or A^- is one dimensional.

In 1981, D. Pixton [4] constructed a counterexample in the general case $R^m \times R^N$ [$m \geq 2, n \geq 2$].

In this paper we construct another counterexample which is different from Pixton's and, using this example, we construct countably many distinct counterexamples on $R^m \times R^2$ ($m \geq 3$).

§2 NOTATIONS AND PROPOSITIONS

To detect countably many distinct counterexamples we use the fluctuations which were used by Walker when he constructed countably many counterexamples in the case that A^+ and A^- are two dimensional (cf. Walker [5]).

Let ψ be a flow on the isolating block B_ψ satisfying (1) and (2) and let $h_\psi: b^+ - a^+ \rightarrow b^- - a^-$ be a map which maps each point $p \in b^+ - a^+$ to the first point in which the semiorbit $p \cdot [0, \infty)$ meets b^- . This map h_ψ is called the Poincaré map of the flow ψ . [The Poincaré map of the standard flow ψ_{mn} is denoted by h_{mn} .]

Let $\chi: B \rightarrow B$ be a homeomorphism on B giving the topological equivalence between the flow ψ and the standard flow ψ_{mn} . Then χ induces

$$\chi|_{b^+}: (b^+, a^+) \rightarrow (b^+, a^+)$$

and

$$\chi|_{b^-}: (b^-, a^-) \rightarrow (b^-, a^-).$$

In general, if the flows ψ and ψ on R^{m+n} are topologically equivalent, then the Poincaré maps h_ψ and h_ψ satisfy

$$(*) \quad (\chi|_{b^-}) \circ h_\psi = h_\psi \circ (\chi|_{b^+ - a^+}).$$

where the homeomorphism χ maps the isolated block B_ψ to B_φ , i.e., h_ψ and h_φ are topologically equivalent.

Since $b^+ - a^+ = \partial D^m \times (D^n - \{0\}) \cong S^{m-1} \times S^{n-1} \times (0,1]$ and $b^- - a^- = (D^m - \{0\}) \times \partial D^n \cong S^{m-1} \times S^{n-1} \times (0,1]$ have (μ, ν, r) -coordinates, the Poincaré map of the standard flow is the identity map with respect to these coordinates.

Let τ_r be $S^{m-1} \times S^{n-1} \times \{r\} \subset S^{m-1} \times S^{n-1} \times (0,1]$ and τ^+ (resp. τ^-) be τ_r in $b^+ - a^+$ (resp. $b^- - a^-$). Let

$$L^+(\mu) = \{\mu\} \times D^n \subset b^+,$$

$$L^+(S^{m-2}) = S^{m-2} \times D^n \subset b^+ \quad [S^{m-2} \text{ is the equator of } S^{m-1}],$$

$$L^+(\nu) = \partial D^m \times \{\nu\} \times (0,1] \subset b^+,$$

$$l_r^+(\mu) = L^+(\mu) \cap \tau_r^+,$$

$$l_r^-(\mu) = L^-(\mu) \cap \tau_r^-,$$

and

$$l_r^+(S^{m-2}) = L^+(S^{m-2}) \cap \tau_r^+.$$

In the same way, let

$$L^-(\nu) = D^m \times \{\nu\} \subset b^-,$$

and

$$l_r^-(\nu) = L^-(\nu) \cap \tau_r^-.$$

Let d_μ (resp. d_ν) be the metric on S^{m-1} (resp. S^{n-1}) $\subset R^m \times R^n \cong R^{m+n}$.

Then d_μ (resp. d_ν) induces a pseudo-metric d_μ (resp. d_ν) on b^+ and b^- ,

i.e., $d_\mu((\mu', \nu', r'), (\mu'', \nu'', r'')) = d_\mu(\mu', \mu'')$ (resp.

$d_\nu((\mu', \nu', r'), (\mu'', \nu'', r'')) = d_\nu(\nu', \nu'')$) then each $L^+(\mu_0)$ has a

ε -neighbourhood $N_\varepsilon^\mu(L^+(\mu_0)) = U\{L^+(\mu) \mid d_\mu(\mu, \mu_0) < \varepsilon\}$ and $L^+(S^{m-2})$ has a

ε -neighbourhood $N_\varepsilon^\mu(L^+(S^{m-2})) = U\{L^+(\mu) \mid d_\mu(S^{m-2}, \mu) < \varepsilon\}$. Here after, the

flow ψ on $R^m \times R^n$ ($m \geq 3$ or $n \geq 3$) is assumed to satisfy (1) and (2).

If the flow ψ has the isolated block B with the m -dimensional stable manifold A^+ and the n -dimensional unstable manifold A^- , then we call ψ $m \times n$ type flow. Let ψ and ϕ be $m \times n$ type flows and suppose the homeomorphism $\chi: B \rightarrow B$ maps the orbits of ψ to the orbits of ϕ . In other words, suppose the Poincaré maps h_ψ and h_ϕ satisfy (*). Then we have the following propositions.

Proposition 1 (Walker [5]). For any $\epsilon > 0$, there exists an $r_\epsilon (> 0)$ such that for any r ($0 < r < r_\epsilon$) the following inclusions hold:

- (i) $(\chi|_{b^+ - a^-}) l_r^+(\mu) \subset N_\epsilon^u(L^+(\chi|_a^+(\mu)))$,
- (ii) $(\chi|_{b^- - a^-}) l_r^-(\nu) \subset N_\epsilon^v(L^-(\chi|_a^-(\nu)))$.

Proposition 2. For any tubular neighbourhood $N(L^+(\chi|_a^+)(S^{m-2}))$ of $L^+(\chi|_a^+)(S^{m-2})$ in b^+ , there exists an $r_N (> 0)$ such that for any $r (< r_N)$ the following inclusions hold:

- (iii) $(\chi|_{b^+ - a^+}) l_r^+(S^{m-2}) \subset N(L^+(\chi|_a^+)(S^{m-2}))$,
- (iv) $(\chi|_{b^- - a^-}) \circ h_\psi l_r^+(S^{m-2}) \subset h_\psi(N(L^+(\chi|_a^+)(S^{m-2})))$.

$$b^+ - a^+ \cong S^{n-1} \times S^{m-1} (0, 1]$$

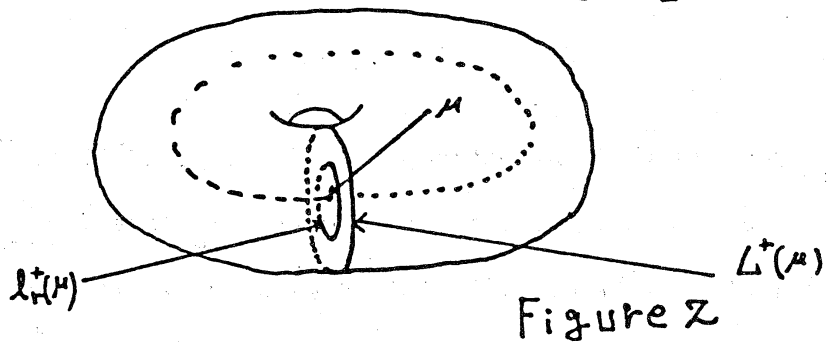

Next theorem is very effective to show the existence of a flow ψ which corresponds with a given Poincaré map.

Theorem 3 (Wilson). Let $P: S^{m-1} \times (0, \varepsilon] \times S^{n-1} \rightarrow S^{m-1} \times (0, \varepsilon] \times S^{n-1}$ be a C^r -diffeomorphism which is strongly C^r -isotopic to the identity relative to $\tau_\varepsilon = S^{m-1} \times \{\varepsilon\} \times S^{n-1}$ ($r > 0$). Then, there is a C^r -flow ψ on B which coincides with the standard type flow ψ_{mn} in a neighbourhood of $A^+ U A^- U \tau^{-1}\{0\}$ and which has the property that $h_\psi|_{S^{m-1} \times (0, 1] \times S^{n-1}} = P$.

Now we proceed to define fluctuations. In this paragraph, let every flow be assumed to be $m \times 2$ type ($m \geq 3$). Let $\Gamma_r: I \rightarrow \tau_r^-$ be a closed arc and consider $\hat{v} \circ \Gamma_r: I \rightarrow R$ where $\hat{v}: b^- \rightarrow R$ is a lift of the circular coordinate function $v: b^- \rightarrow S^1$.

For given Δ ($0 < \Delta < \pi$), let $FL_v(\Gamma_r; \Delta)$ be the cardinal number of v -fluctuations and let $\{s_0, s_1, s_2, \dots, s_n, \dots\} \subset I$ be a sequence of fluctuation points which are defined as follows:

Put $s_0 = 0$ (the origin of \hat{v} coordinate) and $s_1 = \text{Min}\{s \in I \mid |\hat{v} \circ \Gamma_r(s) - \hat{v} \circ \Gamma_r(s_0)| = \Delta\}$ if it exists; otherwise define $FL_v(\Gamma_r; \Delta) = 0$. If s_1 exists then define $\sigma = \text{sign}(\hat{v} \circ \Gamma_r(s_1) - \hat{v} \circ \Gamma_r(s_0))$. If s_{i-1} exists for $i > 1$ then define $s_i = \text{Min}\{s > s_{i-1} \mid \hat{v} \circ \Gamma_r(s) - \hat{v} \circ \Gamma_r(\bar{s}) = (-1)^{i-1} \sigma \Delta\}$ for some \bar{s} ($s_{i-1} \leq \bar{s} \leq s$) if it exists; otherwise define $FL_v(\Gamma_r; \Delta) = i-1$. Now we have the following lemma.

Lemma 4 (Walker). For all Δ ($0 < \Delta < \pi$), there exists an r_Δ (> 0) such that for all r ($0 < r < r_\Delta$) and closed arc $\Gamma_r: I \rightarrow \tau_r^-$ the following inequality holds:

$$FL_v(\Gamma_r; \Delta) \leq FL_v((\chi|_{b^- - a^-}) \circ \Gamma_r; c(\Delta)/2)$$

where

$$c(\Delta) = \text{Min}\{\Delta, \Delta'\} \quad (\Delta' = \text{Min}\{d_v((\chi|_{a^-})(v), (\chi|_{a^-})(v+\Delta)) \mid v \in a^-\})$$

and d_v is the metric on a^- .

Remark. Since a^- is compact, there exists nonzero lower bound of $d_v((\chi|_{a^-})(v), (\chi|_{a^-})(v+\Delta))$.

§3 CONSTRUCTION OF THE COUNTEREXAMPLE

Since the isolating block of $m \times n$ type ($m \geq 3, n \geq 3$) is homeomorphic to $D^m \times D^n$, $b^- - a^-$ is divided into

$$(D^{m-1} - \{0\}) \times \partial D^n \cong S^{m-1} \times (0, 1] \times S^{n-1} \cong S^{m-1} \times (0, 1] \times (I \times S^{n-2} \cup D_+^{n-1} \cup D_-^{n-1}).$$

Changing the order of the product $S^{m-1} \times (0, 1] \times I \times S^{n-2}$, let us consider the coordinate (μ, v_1, v_2, r) on $S^{m-1} \times I \times S^{n-2} \times (0, 1]$.

Let $\bar{I}_1, \hat{I}_1, \bar{I}_2$ and \hat{I}_2 be m -dimensional annuli homeomorphic to $S^{m-2} \times I$. Let the v -coordinates of $\bar{I}_1, \hat{I}_1, \bar{I}_3$ and \hat{I}_3 be c , the v_1 -coordinate of \bar{I}_2 and \hat{I}_2 be d and put e as in Figure 4. (Also see Figure 3.) Let Σ be a C^∞ -isotopically deformed $S^{m-2} \times I$ in $S^{m-1} \times I$ as in Figure 3, and I_i (resp. \hat{I}_i) and Σ ($i=1, 2, 3$) be (v_2, r) -saturation of \bar{I}_i (resp. \hat{I}_i and Σ), i.e., $\Sigma = \{(\mu, v_1, v_2, r) \mid (\mu, v_1) \in \bar{\Sigma}\}$ and $I_i = \{(\mu, v_1, v_2, r) \mid (\mu, v) \in \bar{I}_i\}$.

Firstly, for sufficiently small $r (> 0)$, we construct the diffeomorphism h_ψ which is C^∞ -isotopic to the identity and satisfies $h_\psi(1_r^+(S^{m-2})) = \Sigma \cap 1_r^-$. Here, S^{m-2} denotes the equator of $a^+ \cong S^{m-1}$ and the isotopy preserves (v_2, r) -coordinate and fixes $S^{m-1} \times (0, 1] \times D_+^{n-1}$ and $S^{m-1} \times (0, 1] \times D_-^{n-1}$.

Since the isotopy fixes the small neighbourhood of the boundary $S^{m-1} \times I$ in Figure 3, the μ -coordinates of two endpoints of the interval I coincide. Hence, by taking account of the construction of C^∞ -isotopy and Theorem 3, it will be shown that for given h_ψ there exists an

$m \times n$ -type flow ψ with Poincaré map h_ψ .

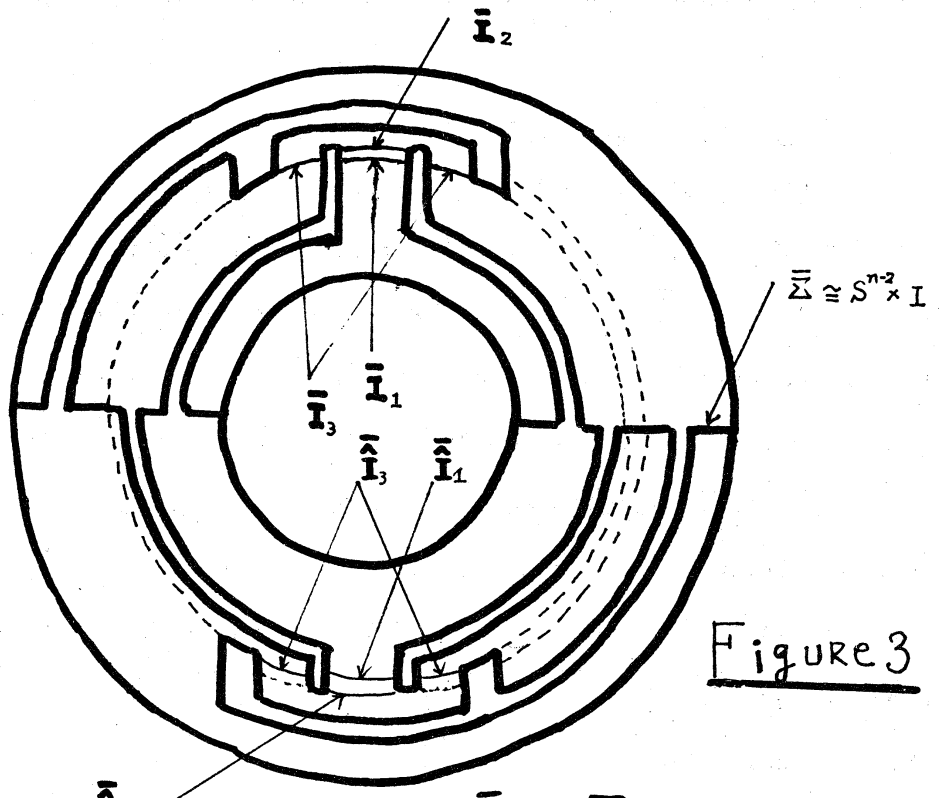

Figure 3

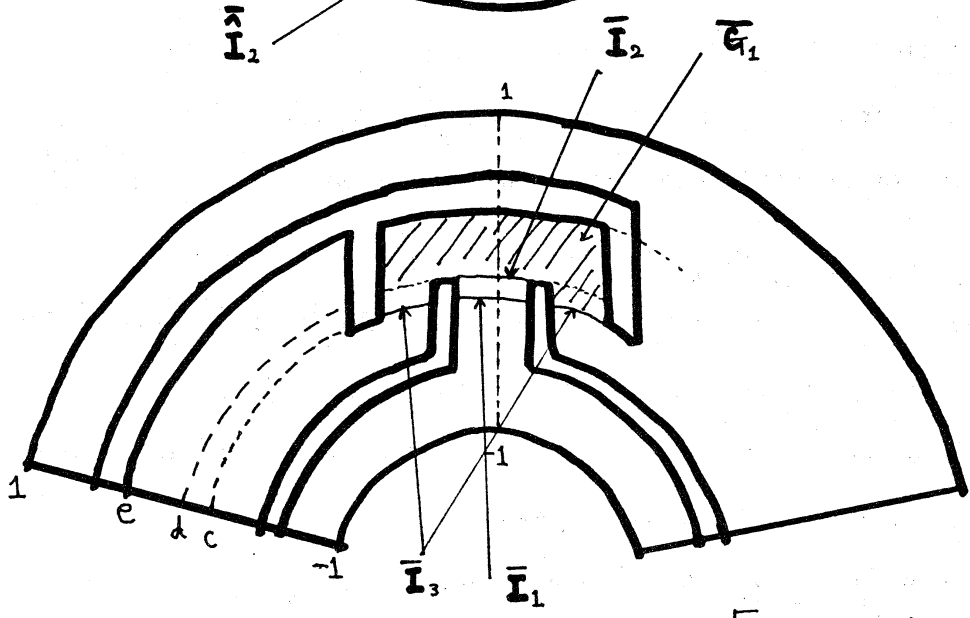

Figure 4

§4 PROOF THAT ψ AND ψ_{mn} ARE NOT TOPOLOGICALLY EQUIVALENT

Suppose that the flows ψ and ψ_{mn} ($m \geq 3, n \geq 3$) are topologically conjugate, i.e.,

$$(1) \quad (\chi|_{b^-}) \circ h_\psi = h_{mn} \circ (\chi|_{b^- - a^-})$$

and let the topological imbedding $\gamma_{r'}: a^- \hookrightarrow b^- - a^-$ be defined by

$\gamma_{r'}(v_1, v_2) = (\chi|_{b^- - a^-})^{-1}(\hat{\mu}_0, v_1, v_2, r')$, here $\hat{\mu}_0$ is an arbitrary element of $\overline{\partial N(L^+((\chi|_{a^+})(S^{m-2})))} \cap a^+$ and r' is chosen smaller than r'_ϵ of which existence is assured in Proposition 1 where $\chi|_{b^-}$ is replaced by $(\chi|_{b^-})^{-1}$. Furthermore, choose r'' sufficiently small so that $(\chi|_{b^- - a^-})(S^{m-1} \times S^{n-1} \times (0, r'')) \subset S^{m-1} \times S^{n-1} \times (0, r'_\epsilon)$, here r'_ϵ is determined according to ϵ and $\chi|_{b^-}$ in Proposition 1, and choose r' to be smaller than $\text{Min}\{r'_\epsilon, r''\}$.

Then $\Gamma_{r'} = \gamma_{r'}(a^-)$ does not intersect Σ by Proposition 2 (iV) since the condition (1) holds.

In fact, the inclusion

$$h_\psi(1_r^+(S^{m-2})) \subset (\chi|_{b^- - a^-}) \circ h_{mn}(N((\chi|_{a^+})(S^{m-2})))$$

holds for any r smaller than $r_0 = \text{Min}\{r'_\epsilon, r_N\}$. On the other hand, by the definition of μ -coordinate of $\Gamma_{r'}$, the inclusion

$$\Gamma_{r'} \subset (\chi|_{b^- - a^-}) \circ h_{mn}(\overline{\partial N((\chi|_{a^+})(S^{m-2}))}) \quad (r' < r_0)$$

holds. Hence it follows from the inclusion $\Gamma_{r'} \subset S^{m-1} \times S^{n-1} \times (0, r'_\epsilon]$

that $\Gamma_{r'}$ does not intersect Σ for any r' smaller than r'_ϵ .

Let G_1 (resp. G_2) be the (v_2, r) -saturation of the shaded region \bar{G}_1 (resp. \bar{G}_2) in Figure 3, i.e., for example,

$$G_1 = \{(\mu, v_1, v_2, r) \in S^{m-1} \times I \times S^{n-1} \times (0, 1] \mid (\mu, v_1) \in \bar{G}_1\},$$

and let

$$(2) \quad H_{r'}^j = \gamma_{r'}^{-1}(G_j) \quad (j=1, 2).$$

Then $\pi(G_1 \cup G_2)$ is included in $\{(v_1, v_2) \mid c < v_1 < e\}$ ($c \in X S^{n-2} \subset a^-$) where $\pi: b^- - a^- \rightarrow a^-$ is the natural projection defined by $\pi(\mu, \nu, r) = (\nu)$.

Let $i_r: a^- \hookrightarrow S^{m-1} \times S^{n-1} \times (0, 1]$ be a topological imbedding defined by $i_r, (v_1, v_2) = (\beta_0, v_1, v_2, r')$, then it follows that

$$(3) \quad \gamma_{r'} = (\chi|_{b^- - a^-})^{-1} \circ i_r, \text{ and}$$

$$(4) \quad d_\nu((\chi|_{a^-})^{-1}(H_{r'}^j), \pi((\chi|_{b^- - a^-})^{-1} \circ i_r, (H_{r'}^j))) < \varepsilon$$

($j=1, 2$).

Hence we have

$$(5) \quad (\chi|_{a^-})^{-1}(H_{r'}^j) \subset \{(v_1, v_2) \mid c - \varepsilon < v_1 < c + \varepsilon\} \quad (j=1, 2).$$

Note that it follows from (2) and (3) that

$$\pi \circ (\chi|_{b^- - a^-})^{-1} \circ i_r, (H_{r'}^j) = \pi \circ \gamma_{r'}, (H_{r'}^j) = \pi(G_j) \quad (j=1, 2).$$

Though $\Gamma_r \cap I_i \neq \emptyset$ or $\Gamma_r \cap I_i = \emptyset$ ($i=1, 2, 3$) hold as in Figure 4,

these conditions do not occur simultaneously since $S^{m-2} \times S^{n-1} \times (0, 1]$ divides $S^{m-1} \times S^{n-1} \times (0, 1]$ into two components. Hence let us assume the

case $\Gamma_r \cap I_i \neq \emptyset$ ($i=1, 2, 3$). (See Figure 6.)

Since $\partial H_{r'}^i = \gamma_{r'}^{-1}(\partial G_i) = \gamma_{r'}^{-1}(I_1 \cup I_3)$, it follows that

$$d_\nu((\chi|_{a^-})^{-1}(\partial H_{r'}^i), \pi \circ (\chi|_{b^- - a^-})^{-1} \circ i_r \circ \gamma_{r'}^{-1}(I_1 \cup I_3)) < \varepsilon \text{ for } r' < r'_\varepsilon.$$

Noting that both I_1 and I_3 are included in

$\{(\mu, \nu_1, \nu_2, r) \mid \nu_1 = c\}$ ($c \in b^- - a^-$) we have

$$(6) \quad \partial(\chi|_{a^-})^{-1}(H_{r'}^1) \subset \{(v_1, v_2) \mid c - \varepsilon < v_1 < c + \varepsilon\} \subset a^-.$$

Now we will show

$$(7) \quad (\chi|_{a^-})^{-1}(H_{r'}^1) \subset \{(v_1, v_2) \mid c - \varepsilon < v_1 < c + \varepsilon\}.$$

Let C be the region $X S^{n-2} \times \{0\} \cap \{(v_1, v_2) \mid v_1 \geq c + \varepsilon\} \subset a^-$, then C is connected. Suppose that $(\chi|_{a^-})^{-1}(H_{r'}^1) \cap C \neq \emptyset$, hence $(\chi|_{a^-})^{-1}(H_{r'}^1)$ includes C . This contradicts (5). Thus $(\chi|_{a^-})^{-1}(H_{r'}^1) \cap C = \emptyset$, and

(7) follows from $\Gamma_r \cap I_2 = \emptyset$ and

$$d_V((X|_a)^{-1} \circ \gamma^{-1}(I_2), \pi_0((X|_{b-a})^{-1} \circ i_r, \gamma^{-1}(I_2))) < \epsilon,$$

where $(X|_a)^{-1} \circ \gamma_r^{-1}(I_2) \subset (X|_a)^{-1}(H_r^1)$ and

$\pi_0((X|_{b-a})^{-1} \circ i_r \circ \gamma_r^{-1}(I_2)) = \pi(I_2) = d$, hence it follows that

$(X|_a)^{-1}(H_r^1)$ must meet $\{(v_1, v_2) \mid d - \epsilon < v_1 < d + \epsilon\}$. This also leads to the contradiction and hence ψ and ψ_{mn} are not topologically equivalent.

Figure 5

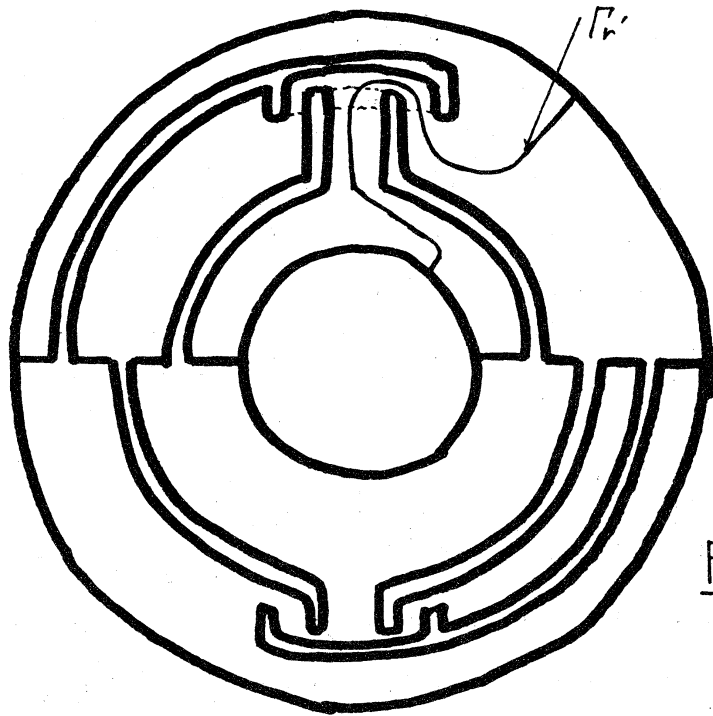
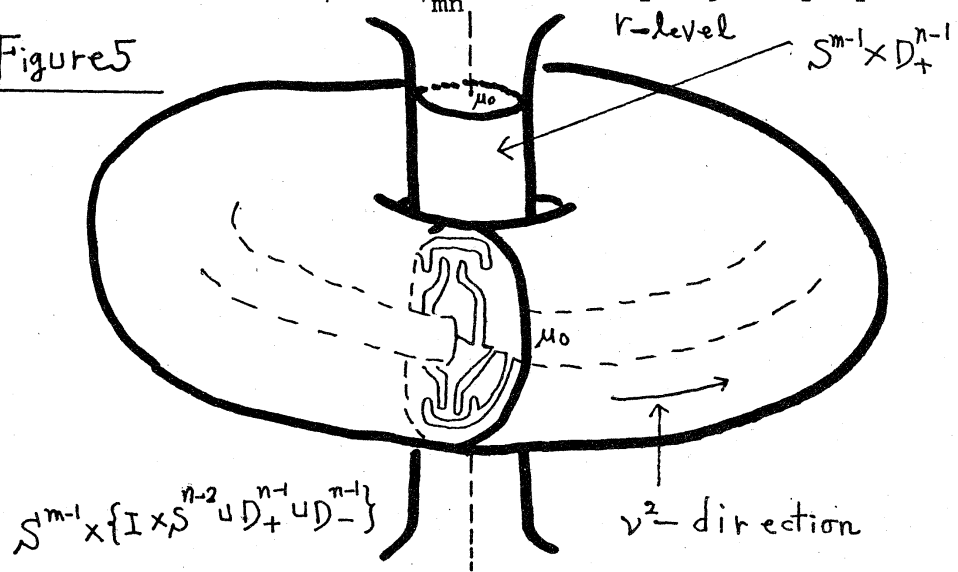

Figure 6

§5 CONSTRUCTION OF THE MULTIPLE EXAMPLE

In this section, all flows are assumed to be of $m \times 2$ type.

$$\text{Thus, } b^+ \cong \partial D^m \times D^2 \cong S^{m-1} \times D^2,$$

$$b^- \cong D^m \times \partial D^2 \cong D^m \times S^1,$$

$$a^+ \cong S^{m-1} \times \{0\},$$

$$a^- \cong \{0\} \times S^1$$

and

$$b^+ - a^+ \cong b^- - a^- \cong S^{m-1} \times S^1 \times (0,1].$$

Divide $S^{m-1} \times S^1$ into $S^{m-1} \times I^+$ and $S^{m-1} \times I^-$ ($I^+ \cup I^- = S^1$) and deform $S^{m-2} \times I^+$ into Σ^+ as in Figure 8 by a diffeomorphism on $S^{m-1} \times I^+$ which is isotopic to the identity relative to $S^{m-1} \times [-1, -1 + \varepsilon_1]$ and $S^{m-1} \times [1 - \varepsilon_2, 1]$, where I denotes $[-1, 1]$ and both ε_1 and ε_2 are sufficiently small positive numbers. On the other hand, $S^{m-1} \times I^-$ remain fixed during the deformation and we call this a standard cassette. Glue this standard cassette and $S^{m-1} \times I^+$ at each boundaries by the identity map $\text{id}: S^{m-1} \rightarrow S^{m-1}$, i.e., glue

$$S^{m-1} \times \{-1\} \subset S^{m-1} \times I^+ \text{ to } S^{m-1} \times \{+1\} \subset S^{m-1} \times I^-$$

and

$$S^{m-1} \times \{+1\} \subset S^{m-1} \times I^+ \text{ to } S^{m-1} \times \{-1\} \subset S^{m-1} \times I^-.$$

Then we obtain a deformed $S^{m-2} \times S^1$ in $S^{m-1} \times S^1$, in other words, we obtain a C^∞ -diffeomorphism which is isotopic to the identity and it deforms $S^{m-2} \times I^+ \subset S^{m-1} \times I^+ \subset S^{m-1} \times S^1$ to Σ^+ as in Figure 8. Using this diffeomorphism, we can construct an r -preserving diffeomorphism on $S^{m-1} \times S^1 \times (0, \varepsilon]$ which is isotopic to the identity relative to $S^{m-1} \times S^1 \times \{\varepsilon\}$ for some small $\varepsilon (> 0)$ [see D.A. Neumann [2]] and is extendable to a C^∞ -diffeomorphism h on $S^{m-1} \times S^1 \times (0, 1]$ such that

$h|_{S^{m-1} \times S^1 \times \{\varepsilon, 1\}}$ is the identity map. By Theorem 4, there is a flow ψ_h

which has h as its Poincaré map.

Now, for sufficiently small r , we can assume that $S^{m-2} \times I^+ \times \{r\}$ ($\subset b^- - a^-$) is Σ^+ as in Figure 8. Denote the deformed $S^{m-2} \times S^1$ in this r -level by Σ_r and let Σ be an r -saturation of Σ_r , then, for small $r > 0$, h satisfies the equality $h(l_r^+(S^{m-2})) = \Sigma \cap \tau_r$ and, in particular, $h(l_r^+(S^{m-2})) \cap S^{m-1} \times I^+ \times \{r\} = \Sigma^+$. Let $S^{m-1} \times I_j$ ($j = 1, 2, 3, \dots, k$) be k -copies of $S^{m-1} \times I$ which have Σ^+ as the deformed $S^{m-2} \times I$ as in Figure 8, and glue $S^{m-1} \times I_1, S^{m-1} \times I_2, \dots$ and $S^{m-1} \times I_k$ one after another at each boundaries in the same way as stated above. Lastly glue a standard cassette.

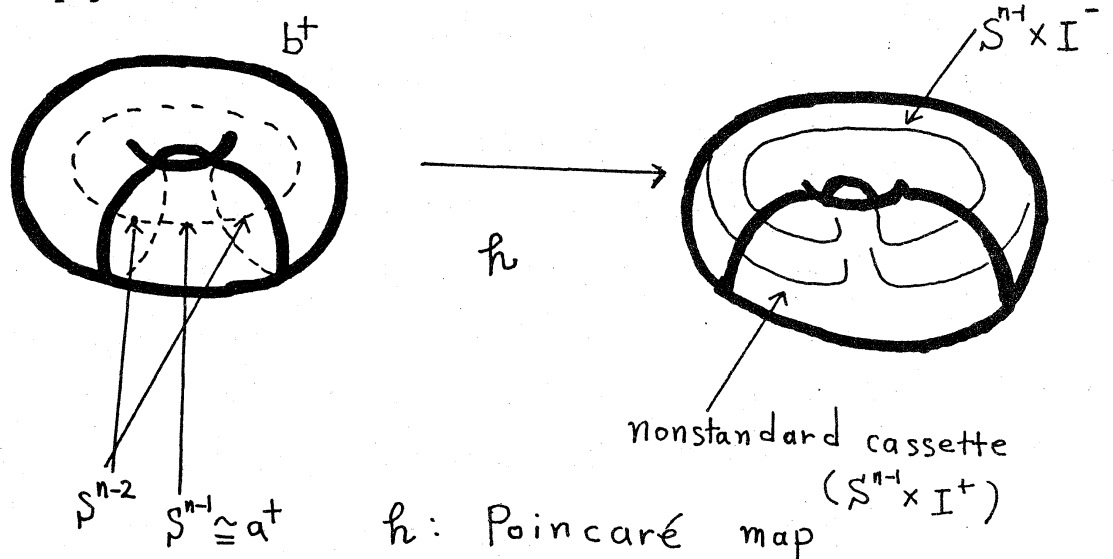

Figure 7

§6 PROOF OF MAIN RESULTS

In this section, we will show that the difference of numbers of nonstandard cassettes leads to countably many nonconjugate flows. (See Figure 10 and 11.) Consider the annulus $S^{m-1} \times I$ obtained by gluing one nonstandard cassette and one standard cassette (see Figure 7). As mentioned in the last section, we get a Poincaré map h_{ψ_j} such that

$h_{\psi_1}(1_r^+(S^{m-2})) \cap I \times S^{m-1} \times \{r\}$ is the annulus $S^{m-2} \times I$ in Figure 7 for small r . By Wilson [7] and Neumann [1], there is a flow ψ_1 of which Poincaré map is equal to h_{ψ_1} . Also consider the annulus $S^{m-1} \times I$ obtained by glueing two nonstandard cassettes and one standard cassette, and construct a Poincaré map h_{ψ_2} such that $h_{\psi_2}(1_r^+(S^{m-2})) \cap I \times S^{m-1} \times \{r\}$ is the annulus $S^{m-2} \times I$ in Figure 9 and a flow ψ_2 of which Poincaré map is equal to h_{ψ_2} .

Suppose that ψ_1 and ψ_2 are topologically conjugate, then the equality $\chi \circ h_{\psi_2} = h_{\psi_1} \circ (\chi|_{b^+ - a^+})$ holds. Hence we have

$$h_{\psi_2}(1_r^+(S^{m-2})) \subset (\chi|_{b^- - a^-})^{-1} \circ h_{\psi_1}(N(L^+(\chi|_{a^+})(S^{m-2})))$$

by Proposition 2 (iv). Define, as in section 4, a differentiable imbedding $\alpha_r^\mu : a^- \hookrightarrow \tau_r$ by $\alpha_r^\mu(\mu, \nu) = (g_\mu(\mu, \nu), g_\nu(\mu, \nu), r)$ for any $\mu_0 \in S^{m-1} - N(L^+(\chi|_{a^+})(S^{m-2}))$ and small positive number r .

Here we suppose that both $\alpha_r^\mu(a^-) \cap \partial I^+ \times S^{m-1} \times \{r\}$ and $\alpha_r^\mu(a^-) \cap \partial I^- \times S^{m-1} \times \{r\}$ have the same μ -coordinate μ_0 and g_μ (resp. g_ν) is the μ (resp. ν)-coordinate function when $S^{m-1} \times S^1 \times \{r\}$ is divided into $S^{m-1} \times I^+ \times \{r\}$ and $S^{m-1} \times I^- \times \{r\}$. (See Figure 11.)

Since S^{m-2} is differentiably imbedded in S^{m-1} , we can choose an arc α so that its fluctuation is less than three and

$$\alpha \cap h_{\psi_1}(N(L^+(\chi|_{a^+})(S^{m-2}))) = \emptyset \text{ for some small positive number } \varepsilon.$$

In particular, choose α_r^μ as such an α and apply Lemma 4 to

$$(\chi|_{b^- - a^-})^{-1} \circ \alpha_r^\mu = \Gamma_r,$$

$$FL_\nu(\Gamma; \Delta) \leq FL_\nu((\chi|_{b^- - a^-}) \Gamma_r; c(\Delta)/2) \leq 3,$$

where $\Delta = |\tilde{\nu}(I_1) - \tilde{\nu}(I_2)|$. (See Figure 11.) This contradicts

$FL_\nu(\Gamma; \Delta) \geq 5$ (see Figure 12), and we conclude that ψ_1 and ψ_2 are not topologically conjugate.

Moreover, we can show inductively that two B_{m_2} flows ($m \geq 3$) are not orbit conjugate if the numbers of nonstandard cassettes are different from each other.

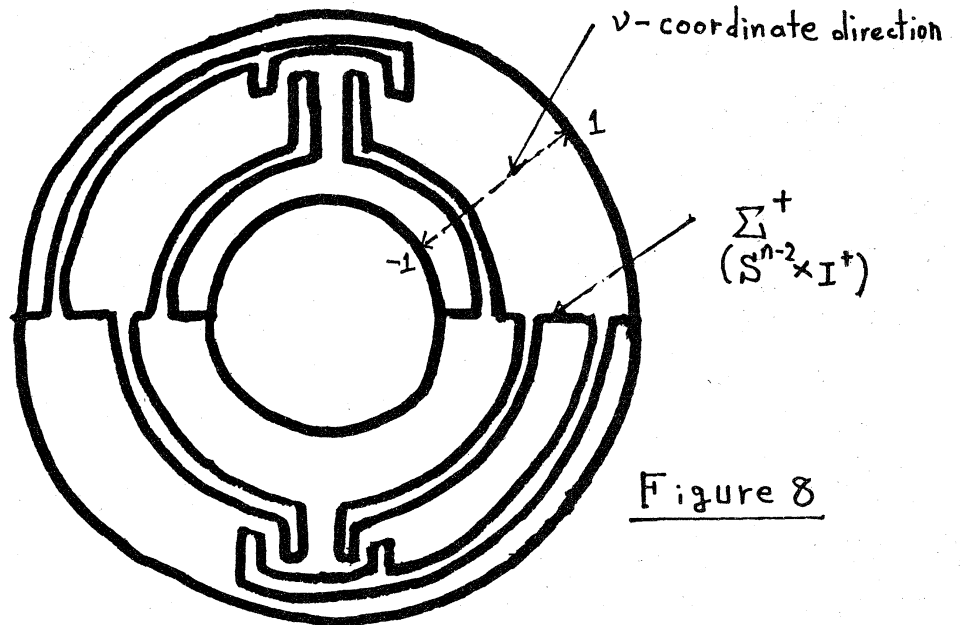

Figure 8

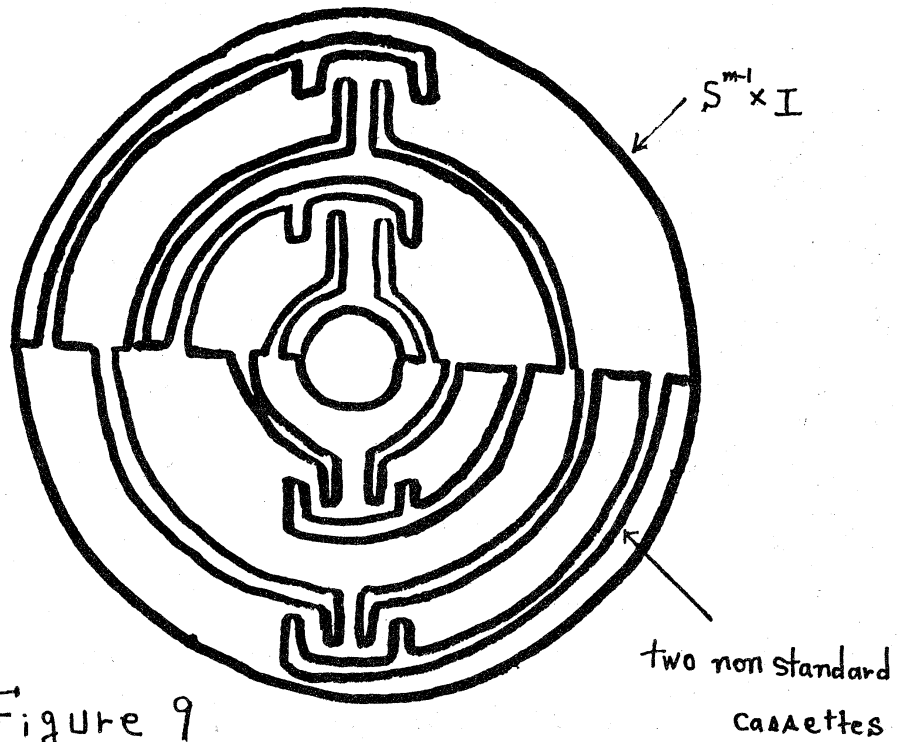

Figure 9

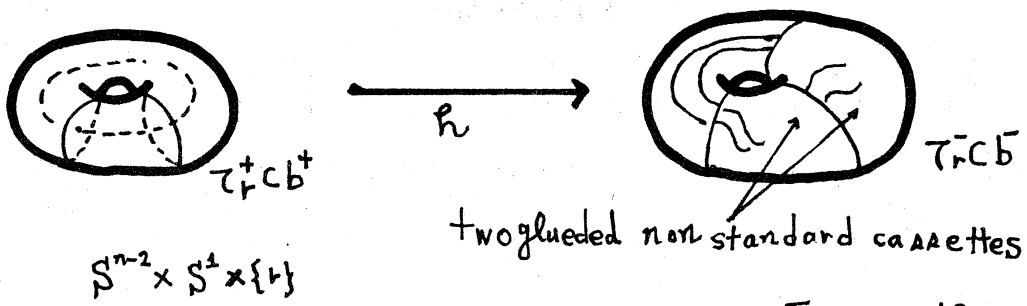

Figure 10

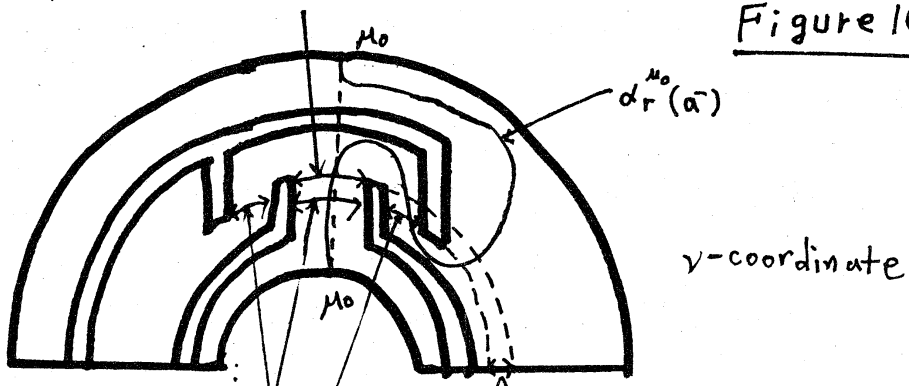

Figure 11

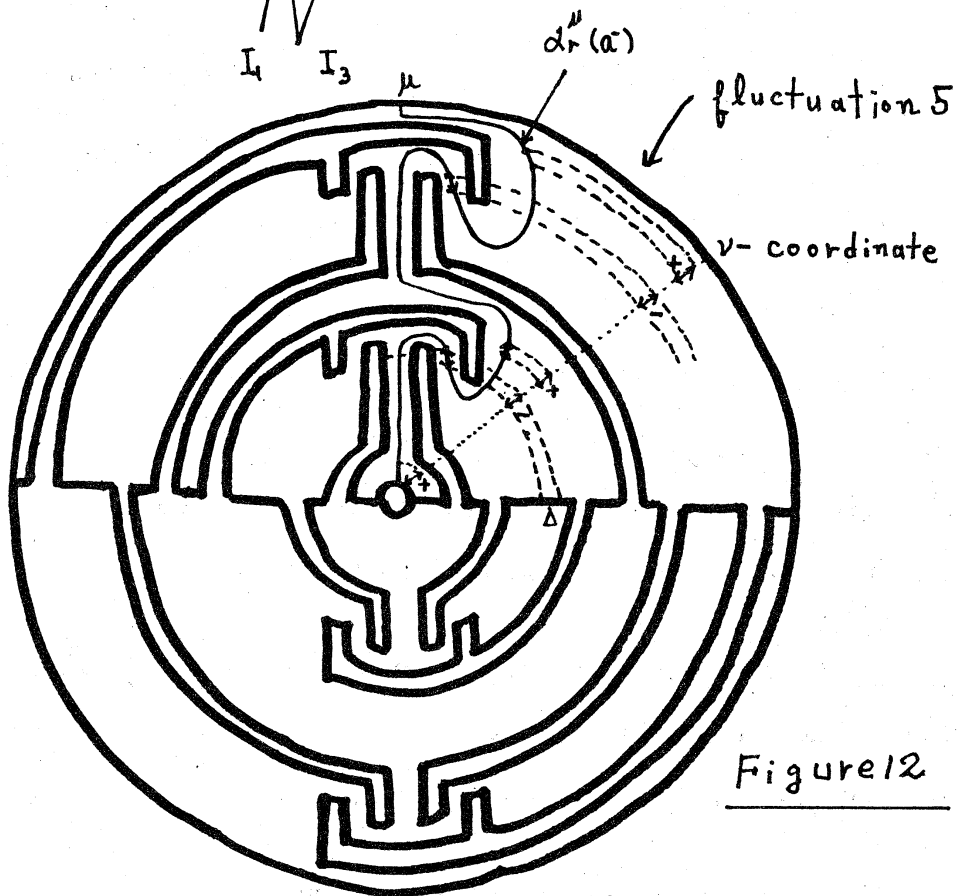

Figure 12

REFERENCES

- [1] C. Coleman; Hyperbolic stationary points, in Reports of the Fifth International Congress on Nonlinear Oscillations, Vol. 2 (Qualitative Methods) Kiev, (1970), 222-226.
- [2] D. Neumann; Topologically hyperbolic equilibria in dynamical systems, J. Differential Equations 37 (1980), 49-59.
- [3] _____; Uncountably many distinct topologically hyperbolic equilibria, Global Theory of Dynamical Systems, Lecture Notes in Math. Vol. 819, Springer, New York, 1980, 340-352.
- [4] D. Pixton; More counterexamples to Coleman's conjecture, Proc. Amer. Math. Soc. Vol. 82, No.1 (1981), 145-148.
- [5] R.B. Walker; Conjugacies of topologically hyperbolic fixed Points: A necessary condition on foliations, Global Theory of Dynamical Systems, Lecture Notes in Math. Vol. 819, Springer, New York, 1980, 446-457.
- [6] F.W. Wilson; A reformulation of Coleman's conjecture concerning the local conjugacy of topologically hyperbolic singular points in structure of attractors in dynamical systems, Lecture Notes in Math. No. 668, Springer, New York, 1980, 245-252.
- [7] _____; Coleman's conjecture on topological hyperbolicity, Global Theory of Dynamical Systems, Lecture Notes in Math. vol. 819, Springer, New York, 1980, 458-470.
- [8] _____; A uniform continuity condition which is equivalent to Coleman's conjecture, J. Differential Equations 36 (1980), 12-19.